

行政院國家科學委員會補助專題研究計畫 成果報告
 期中進度報告

UMTS 即時計費協定之研究 (第 3 年)
A Study on UMTS Online Charging Protocol

計畫類別： 個別型計畫 整合型計畫

計畫編號：NSC 97-2221-E-009-143-MY3

執行期間：2010 年 08 月 01 日至 2011 年 07 月 31 日

執行機構及系所：國立交通大學資訊工程學系

計畫主持人：林一平

共同主持人：

計畫參與人員：

成果報告類型(依經費核定清單規定繳交)： 精簡報告 完整報告

本計畫除繳交成果報告外，另須繳交以下出國心得報告：

赴國外出差或研習心得報告

赴大陸地區出差或研習心得報告

出席國際學術會議心得報告

國際合作研究計畫國外研究報告

處理方式：除列管計畫及下列情形者外，得立即公開查詢

涉及專利或其他智慧財產權， 一年 二年後可公開查詢

中 華 民 國 100 年 07 月 08 日

一、 中文摘要

整合型電信應用服務包括語音、資料、影像服務之整合，電信營運商為提供不同的加值服務以迎合客戶需求，需要處理複雜的服務與網路管理。若缺乏完整的營運支援系統，很難即時、有效率地依據客戶需求提供有競爭力的服務。本計畫前兩年著重在UMTS之即時計費。第三年則將即時計費之經驗應用於電信營運系統。本研究以新一代營運系統及軟體為基礎，發展電信營運支援系統，以支援電信服務及IT服務的實行。依據標準電信營運流程，本系統整合四類營運支援系統：TOSS-P（智慧型服務佈建），TOSS-N（整合性大型網路管理），TOSS-T（故障處理及排解），and TOSS-Q（點對點服務品質管理）。我們以網路協定電視及IP虛擬專屬網路之營運模式，展示這些營運支援系統如何協同運作以支援日常之企業營運，並達到降低成本及加速收益的優點。

關鍵詞：營運支援系統，新一代營運系統及軟體，增強式電信營運藍圖，網路協定電視，IP虛擬專屬網路

Abstract- Due to the convergence of voice, data, and video, today's telecom operators are facing the complexity of service and network management to offer differentiated value-added services that meet customer expectations. In the first two years of this project, we have studied UMTS Online Charging Protocol. This year we apply the online charging experience to Business Support System/Operations Support System (BSS/OSS). Without the operations support of well-developed BSS/OSS, it is difficult to timely and effectively provide competitive services upon customer request. In this study, a suite of NGOSS-based Telecom OSS (TOSS) is developed for the support of fulfillment and assurance operations of telecom services and IT services. Four OSS groups, TOSS-P (intelligent service provisioning), TOSS-N (integrated large-scale network management), TOSS-T (trouble handling and resolution), and TOSS-Q (end-to-end service quality management), are organized and integrated following the standard telecom operation processes (i.e., eTOM). We use IPTV and IP-VPN operation scenarios to show how these OSS groups co-work to support daily business operations with the benefits of cost reduction and revenue acceleration.

Keywords: Operations Support System (OSS), New Generation Operations Systems and Software (NGOSS), enhanced Telecom Operations Map (eTOM), Internet Protocol Television (IPTV), IP-Virtual Private Network (IP-VPN)

二、 前言

Today, telecom operators are facing many challenges introduced by provisioning diversified and digital convergent services in a fast-changing multi-technology network environment. In the first two years of this project, we have studied UMTS Online Charging Protocol. This year we apply the online charging experience to BSS/OSS. It is essential that a telecom operator quickly respond to market and technology changes, satisfy customer needs, and reduce operational expenditure (OPEX). To address these issues, the telecom operator's Operations Support System (OSS) must meet the following requirements: automated service provisioning for fast service fulfillment, proactive and reactive monitoring for end-to-end quality assurance, efficient and effective trouble handling, and high flexibility of customization and adjustment for offering new products to market in time.

To fulfill the above requirements, Chunghwa Telecom has developed a series of OSSs called Telecom OSS (TOSS). These OSSs support the operational processes for broadband service delivery and quality assurance where the customer needs for new contents and services are constantly changing, and sometimes unpredictable. The design of TOSS is compliant to the enhanced Telecom Operations Map (eTOM) framework of New Generation Operations Systems and Software (NGOSS) [1]. As illustrated in Figure 1, eTOM defines a comprehensive telecom business process model for service providers (e.g., telecom operators and content providers). There are three major process areas: *Strategy, Infrastructure and Product* (SIP; Figure 1 (a)) for planning and life cycle management, *Enterprise Management* (EM; Figure 1 (b)) for corporate or business management, and *Operations* (OPS; Figure 1 (c)) for core operational management. As the heart of eTOM, the OPS consists of two vertical process groups, i.e., *Operation Support & Readiness* (OSR) and *Fulfillment, Assurance, Billing* (FAB) which are the focal point of

eTOM framework [2][3]. These vertical process groups represent a view of flow-through of activities where the OSR enables support and automation for FAB real-time processes. The OPS can also be viewed horizontally through *Customer Relationship Management (CRM)*, *Service Management & Operations (SM&O)*, *Resource Management & Operations (RM&O)* and *Supplier/Partner Relationship Management (S/PRM)* that represent functionally-related activities.

Chunghwa Telecom’s TOSS mainly supports the processes of the OPS in fulfillment and assurance vertical flows overlaid in the CRM, SM&O and RM&O horizontal levels. In this study, the terms *customer*, *product*, *service*, and *resource* follow eTOM definitions: A customer (a person or a company) purchases products from the *service providers*. A product may

include one or more services, hardware, processed materials, software or their combinations. Services are developed by a service provider for sale within products. The same service may be included in multiple products that are packaged differently with different prices. The resources refer to the physical or logical resources (including both network and IT) needed for constructing services or products.

Based on the eTOM structure, Section 3 introduces the major subsystems of TOSS, explains how they map to eTOM, and illustrates the corresponding end-to-end operational scenarios. Sections 4 elaborates on the implementations of TOSS subsystems. Section 5 concludes our work with the operational statistics of TOSS in Chunghwa Telecom.

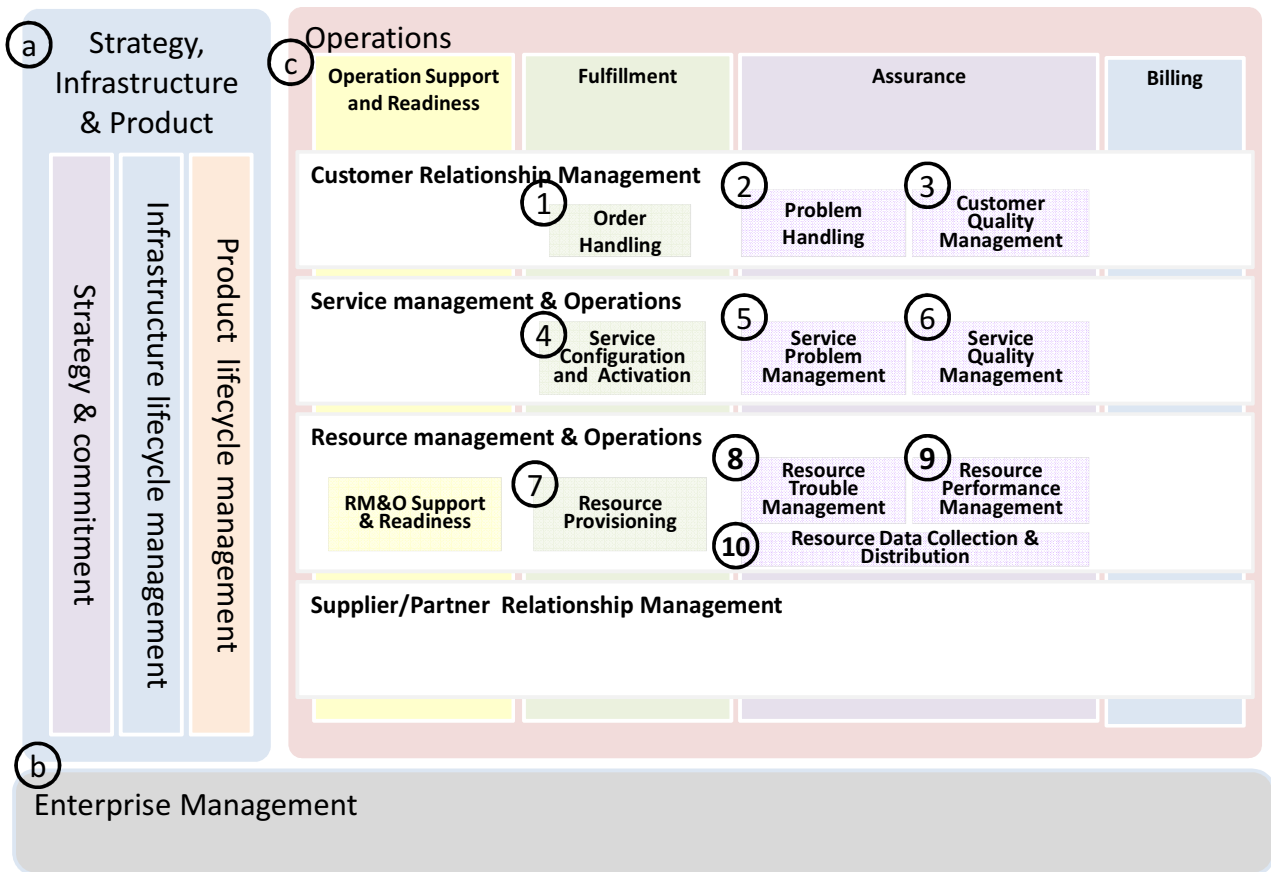

Figure 1. eTOM framework

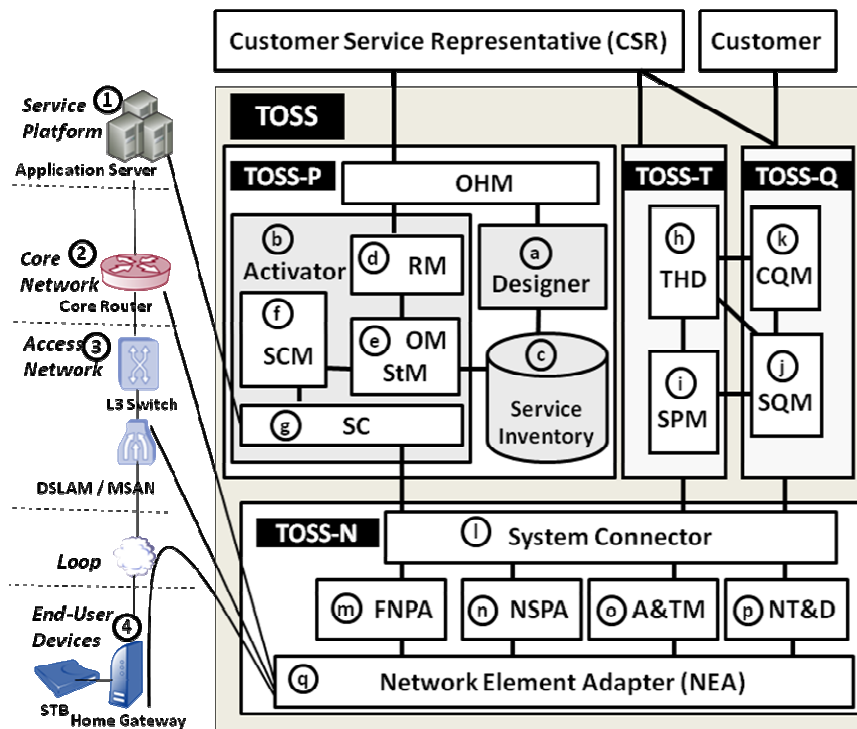

Figure 2. TOSS architecture (and an example of management for IPTV)

三、 研究目的與文件探討

As illustrated in Figure 2, TOSS contains four major subsystems: TOSS-P (Provisioning), TOSS-N (Network Management), TOSS-T (Trouble Management) and TOSS-Q (Quality Management).

TOSS-P corresponds to *Order Handling* (Figure 1 (1)) and *Service Configuration & Activation* in eTOM (Figure 1 (4)). TOSS-P supports light-weight *Order Handling Management* (OHM) to accept customer orders. Since TOSS-P is modularly designed with open interfaces, the OHM developed by Chunghwa Telecom can be easily replaced by other corporate or commercial order handling systems. TOSS-P implements service design functions that translate customer ordered products into service specifications and design how these services should be configured. After that, it instructs TOSS-N and service platforms (Figure 2 (1)) to perform service activation.

TOSS-N corresponds to eTOM *RM&O* processes (Figure 1 (7)-(10)). This subsystem provides a complete carrier-grade solution for management of large heterogeneous telecommunications networks as well as information technology (IT) servers. TOSS-N conducts all resource-level activities including resource activation, resource testing, resource

trouble detection, and resource performance monitoring. In Figure 2, we use the Internet Protocol Television (IPTV) service [4] as an example for management, where all network elements for constructing the IPTV service are resources to be managed by TOSS-N. These network elements include the ATM switches or MPLS-based routers in core networks (Figure 2 (2)); the Digital Subscriber Line Access Multiplexers (DSLAM), the Multi-Service Access Nodes (MSAN), or the Layer 2 and Layer 3 switches in xDSL or FTTx access networks (Figure 2 (3)), and the end-user devices such as home gateways or set-top boxes (STBs) located in customer premises (Figure 2 (4)). In this study, the terms *device* and *network element* are used alternatively to represent network and end-user equipment.

TOSS-T corresponds to *Problem Handling* and *Service Problem Management* processes in eTOM (Figure 1 (2) and (5)), which handles troubles reported by customers. Specifically, TOSS-T generates trouble tickets, dispatches them to the appropriate operators (e.g., network maintenance operators, field operators, etc.), and tracks them until the problems are resolved and the services are restored. TOSS-T also interacts with TOSS-N to perform resource testing functions that assist the operators to identify and locate the causes of the service problems.

TOSS-Q corresponds to *Customer Quality Management* and *Service Quality Management* in eTOM (Figure 1 (3) and (6)), which utilizes the network management information monitored by TOSS-N to conduct service performance analysis based on the views from both service providers and specific customers. For service provider, TOSS-Q is able to detect and notify regional service degradation in advance to avoid business disaster. For particular customers, TOSS-Q detects QoS degradation to avoid service level agreement (SLA) violations. Besides, TOSS-Q provides service quality statistics reports for customers who sign on the SLA for guaranteed quality level.

In summary, TOSS-P works with TOSS-N to support end-to-end *fulfillment process flow* to timely provide customers with their requested products. TOSS-T and TOSS-Q work with TOSS-N to support end-to-end *assurance process flow* to ensure the services provided to customers, which are continuously available to meet the SLA or Quality of Service (QoS) performance levels. TOSS-P, TOSS-T and TOSS-Q provide user interfaces to customer service representatives (CSR; i.e., operators in front desk or service center) for handling customer orders and trouble appeals. TOSS-N manages the multi-technology resources and hides the resource management complexity from TOSS-P, TOSS-T and TOSS-Q.

四、 研究方法

1. INTELLIGENT SERVICE PROVISIONING (TOSS-P)

TOSS-P provides a unified approach to bundle service features across various service platforms (Figure 2 (1)) so that these service features appropriately appear to the customers as products. In addition to the light-weight OHM mentioned in the previous section, TOSS-P includes two more components. The *Designer* (Figure 2 (a)) carries out necessary readiness processes (to design service specifications, provision rules, and so on) before a product is available in the market. Then the product can be ordered by a customer through the OHM. The *Activator* (Figure 2 (b)) receives every order request from the OHM and executes provisioning activities according to the resource budgets and rules. To support end-to-end service provisioning lifecycle management, the *Service Inventory* (Figure 2 (c)) stores all service definitions and activation knowledge to be accessed by the Designer and the Activator.

1.1. TOSS-P Designer

Before introducing a new or blended service such as IPTV, the Designer implements design tasks for wrapping up candidate services into new product offerings in the OHM. Specifically, the Designer proposes candidate service specifications to present business view of a new service. For example, an IPTV service specification can be easily augmented with value-added features such as “payment allowance” or “video sharing” by the Designer to meet customer needs.

The Designer either creates new service specifications or reuses existing service specifications in the Service Inventory to generate new composite service specifications. Through the Designer web-based portal, a product manager retrieves, modifies and creates service specifications. For example, the manager may create a composite IPTV service including FTTx connectivity and IPTV multimedia service specifications. As illustrated in Figure 3 (2), a 32-bit *object ID* uniquely identifies the specification for FTTx. Through *ServiceSpecCharacterizedBy* (Figure 3 (3)-(8)), the Designer describes the FTTx service characteristics such as *upstream rate*, *downstream rate*, *class of service* and so on. Under the object ID, these service specification characteristics are retrieved and managed in the Service Inventory. Every service specification characteristic is set up with its parameters. For the FTTx example, the *valueFrom* (the lower bound of the upstream rate) is 2 Mbps (Figure 3 (7)) and the *valueTo* (the upper bound) is 20 Mbps (Figure 3 (8)).

Besides managing service specifications, the Designer defines a provision sequence for every service. For the IPTV service, the first step of the sequence reserves connectivity and the IP address of the STB. The second step configures the circuit and user profile at the IPTV application server. This sequence is executed when a customer subscribes to the IPTV product.

The Designer defines error/exception handling in a provision sequence. For example, if the IPTV application servers are disconnected or temporarily failed during the activation

process, an exception-handling process is initiated to resolve the problem and inform the operators as well. The Designer also sets the alert criteria to monitor the status of a provision sequence. For example, the IPTV service platform should finish provision task in 2 minutes, otherwise TOSS-P will report an exception alert to the system administrator.

After finishing the design for service specifications, provision sequence and exceptional handling, the Designer automatically publishes these service specifications to the OHM for product manager to wrap up various product offerings (e.g., the IPTV service specifications can be used to define the Olympics Games package or sports packages for NBA season options).

1.2. TOSS-P Activator

The Activator accepts customer orders from the OHM. Every customer order includes a product instance that specifies the product name (Figure 4 (2)) such as Multimedia on Demand (MOD; an IPTV product of Chunghwa Telecom) [4] and a *Customer Facing Service* (CFS) instance which consists of several characteristics such as the uplink bandwidth of IPTV connectivity (Figure 4 (6)). The specification in Figure 4 (7)-(9) enforces the value in Figure 4 (6) to be restricted in the range [2M, 20M] defined in Figure 3 (6)-(8).

Note that the CFS instance is created when a customer subscribes to a product at the first time.

After this order is handled, the updated CFS instance is stored in the Service Inventory. For a subsequent order requested by the customer (e.g., upgrade bandwidth from 2Mbps to 10Mbps), the CFS instance of the customer order will be recognized, retrieved from the Service Inventory, updated, and then stored back to the Service Inventory.

The *Request Manager* (RM; Figure 2 (d)) receives a customer order from the OHM through a common *Service Activation Interface* (SAI) [5]. The SAI supports several options that allow the OHM to instruct TOSS-P to perform *actions* (activate, cancel, modify, finalize, etc.) on services for lifecycle management.

The RM extracts the CFS instance from the customer order and passes it to the Order Manager (OM; Figure 2 (e)). Based on the CFS instance, the OM controls the provision workflow that implements the Service Configuration & Activation process in eTOM (see Figure 1 (4)). Specifically, the OM instructs the *State Manager* (StM; Figure 2 (e)) to run a *finite state machine* (FSM) for every CFS instance. This FSM is driven by the action specified by the OHM. Figure 5 illustrates a partial state transition diagram for the FSM. Every time the Activator finishes a customer order, the StM moves the FSM of the CFS instance to a new state, and saves it in the Service Inventory. When the customer issues the next order, the state stored in the Service Inventory will be retrieved with the OHM action to drive the FSM.

```

1  · ServiceSpecCharUse ·
2  · objectID · 37b1ebc-45e7-43b0-93e7-ca5b9865213f · objectID ·
   ······
3  · ServiceSpecCharacterizedBy ·
4  · · description · upstream rate for FTTX connectivity · description ·
5  · id · 6413e38c-50cf-409a-8755-8102b242ae5d · id ·
   ······
6  · name · UpstreamRate · name ·
   ······
   · ServiceSpecTakesOn ·
   · ServiceSpecCharacteristicValue ·
   · · objectID · 04ec6d9b-ecfd-419b-a7b5-e6a4a3b71655 · objectID ·
7   · · valueFrom · 2M · valueFrom ·
8   · · valueTo · 20M · valueTo
   · ServiceSpecCharacteristicValue ·
   · ServiceSpecTakesOn ·
   · ServiceSpecCharacterizedBy ·
   · ServiceSpecCharUse ·

```

Figure 3. FTTx connectivity service specification

```

1 <Product>
  <ID xmlns="">98XOSCAN111299</ID>
  <BusinessInteractionItemInvolvesProduct>
    <objectID>1220056261</objectID>
2   <name>MOD Product</name>
  ...
  <ProductRealizedAsCFSservice>
3   <CustomerFacingService >
    <objectID>PBXCFSID198XOSCAN103610</objectID>
    <id>PBXCFSID198XOSCAN111299</id>
    <ServiceCharacterizedBy>
4     <ServiceCharacteristic>
5       <description>IPTV connectivity uplink bandwidth</description>
6       <value>2M</value>
7       <CustomerFacingServiceSpecForSpecifiesCustomerFacingService xsi:type="q2:CustomerFacingServiceSpecComposite">
8       <description>upstream rate for FTTX connectivity</description>
9       <id>6413e38c-50cf-409a-8755-8102b242ae5d</id>
10      <name>UpstreamRate</name>
    </ServDefSpecCharacterizedBy>
  ...

```

Figure 4. Product instance in the customer order

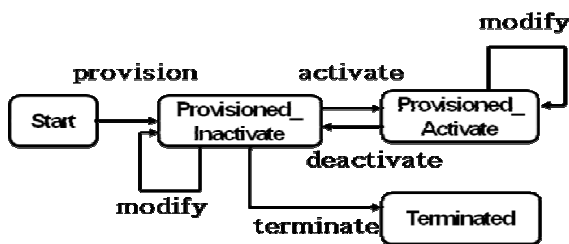

Figure 5. A partial service operation state transition diagram

Service Provision: When a customer orders a new product, e.g., IPTV, the OHM issues a customer order with action “provision”. The StM creates the FSM for the CFS instance with the initial state Start. The OM instructs the *Service Component Manager* (SCM; Figure 2 (f)) to provision the IPTV service. Specifically, the SCM dispatches two *Service Components* (SCs; Figure 2 (g)) to reserve required resources in TOSS-N and service platforms. The *connectivity SC* instructs TOSS-N to allocate end-to-end connectivity including core network, access network, loop and the STB at the customer site. The *IPTV middleware SC* interacts with IPTV service platform to enable user account and subscription profile of particular program packages or application options.

Finally, the StM moves the FSM from the Start state to Provisioned_Inactivate, and save the new state together with the updated

CFS instance in the Service Inventory. At this state, all resources required to provision IPTV service are allocated, but not yet activated.

Service Activation: For a service at the Provisioned_Inactivate state, the customer is ready to activate the product. The customer may request the OHM to issue a customer order with action “activate”. The OM obtains the CFS instance from the Service Inventory and the customer order, and requests the SCM to activate the IPTV service. The SCM uses the connectivity and the IPTV middleware SCs to activate the resources through TOSS-N and service platforms. Then the StM changes the FSM state from Provisioned_Inactivate to Provisioned_Activate, and saves the new state together with the updated CFS instance in the Service Inventory. At this point, the customer can enjoy the product.

Service Deactivation: When the IPTV service is in use (i.e., it is at the Provisioned_Activate state), the customer may decide to suspend it for a time period. If so, the OM instructs the SCM to deactivate the service. Specifically, the connectivity and IPTV middleware SCs suspend or lock all network and service resources. The StM moves the FSM to the Provisioned_Inactivate state, and saves it in the Service Inventory.

Service Termination: When the IPTV service is at the Provisioned_Inactivate state, the customer may terminate the service. The OM instructs the SCM to “terminate” the

underlying network and service resources which will not be activated for this product again. The StM moves the FSM to the Terminated state. Note that we cannot terminate a service directly from the Provisioned_activate state. For example, a customer may travel and forget to pay the bill, and it is appropriate to temporarily deactivate the service, and actually terminate the service until we are sure that the customer confirms service termination.

Service Modification: When the IPTV service is at the Provisioned_Activate state, the customer may request to change the service profile; e.g., to upgrade the Internet service uplink bandwidth from 2 Mbps to 4 Mbps or upgrade the class of IPTV service from *Standard Definition TV* (SDTV) to *High Definition TV* (HDTV). The OM instructs the SCM to modify the network and service resources. The FSM state remains the same.

In the lifecycle of a product, the OM maintains a service order ID linking to the corresponding customer orders from the OHM. The service provider will continually check the execution status of TOSS-P for the customer orders through this service order ID.

2. INTEGRATED NETWORK MANAGEMENT (TOSS-N)

TOSS-N performs centralized management of large heterogeneous networks that are geographically distributed. TOSS-N consists of

six components. The *System Connector* (Figure 1 (l)) connects TOSS-N to TOSS-P, TOSS-Q, and TOSS-T. By using *Java Message Service* (JMS) and web service, the System Connector is implemented on the loosely-coupled *service-oriented architecture* (SOA) [6][7]. The *Flow-through Network Provisioning & Activation* (FNPA; Figure 2 (m)) processes the requests from TOSS-P to automatically configure and activate the network elements. The *Network Status & Performance Analysis* (NSPA; Figure 2 (n)) collects measured data and analyzes network status. The *Alarm & Ticket Management* (A&TM; Figure 2 (o)) creates event tickets when some faults were detected at the network elements, and issues the fault alarms to the related operators through short messages or e-mails. The *Network Test & Diagnosis* (NT&D; Figure 2 (p)) handles network test requests from TOSS-T to detect abnormal operations of the network elements. The *Network Element Adapter* (NEA; Figure 2 (q)) monitors and controls broadband network elements with multiple protocols such as SNMP, TL1, CLI/Telnet, HTTP, CORBA, and TR-069 [8]. In Chunghwa Telecom's commercial operation, TOSS-N manages hundred types of broadband network elements over 40 vendors.

We use three operation scenarios to illustrate how TOSS-N interacts with TOSS-P, TOSS-T and TOSS-Q to deal with IPTV service fulfillment and assurance activities.

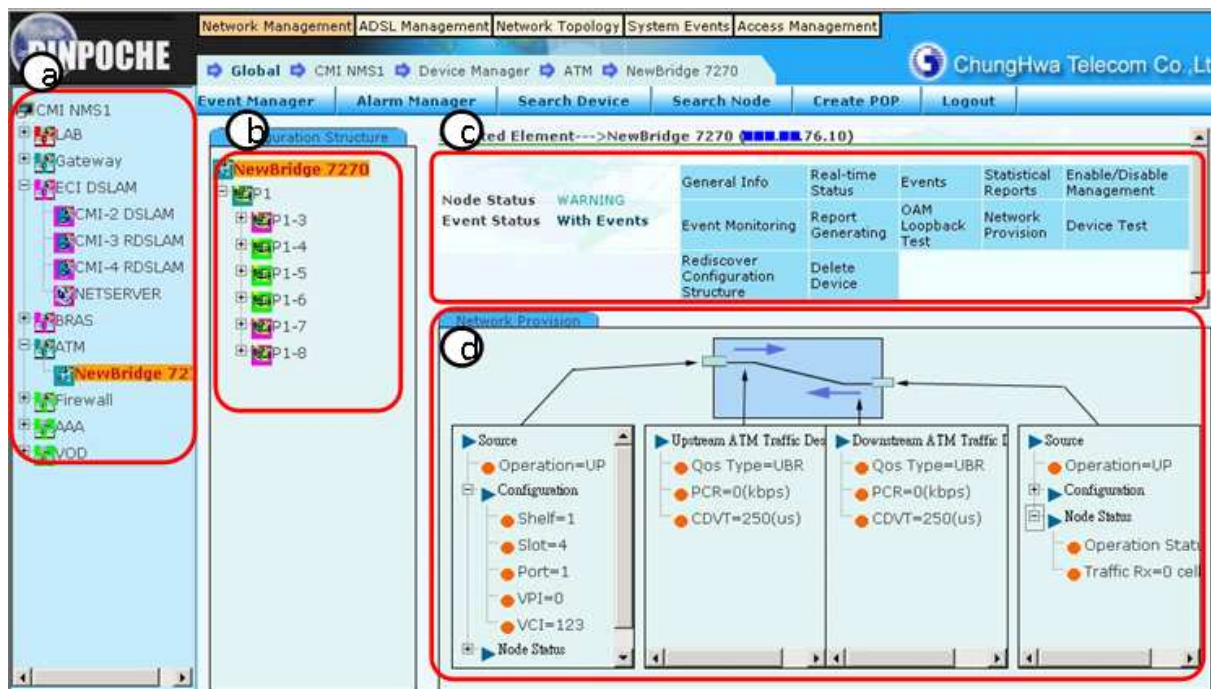

Figure 6. Web-based TOSS-N network management

2.1. Network Provisioning and Activation

To provision a service, TOSS-P issues the network circuit reservation request to TOSS-N. The System Connector (Figure 2 (l)) dispatches this request to the FNPA (Figure 2 (m)) to check if the service can be fulfilled with the support of the underlying network. For IPTV service, feasibility checks include the evaluation of network bandwidth (for delivering video data) and the distance between the service provider's central office and the customer site. After service feasibility checks, the FNPA reserves the network resources (e.g., specific ports and VLANs of L2/L3 switches) for this IPTV service. After resource reservation, TOSS-P may activate this IPTV service by issuing the network activation order to TOSS-N. In response to this request, the FNPA activates the connectivity circuits from the core network to end-user devices through the access network. The FNPA then requests the NT&D (Figure 2 (p)) to test the activated network elements to ensure that the network circuit is ready to transmit IPTV video data.

TOSS-N manages network elements with multiple vendors, models, and technologies. For IPTV, a variety of broadband network elements (e.g., DSLAM, MSAN, L2/L3 switches and core routers) are managed and displayed in the TOSS-N management portal shown in Figure 6. For example, if one clicks on an Alcatel Newbridge 7270 ATM switch in Figure 6 (a), Figure 6 (b) will show the shelf (e.g., P1), slot (e.g., P1-3) and port information of the switch in a hierarchical tree structure. Figure 6 (c) provides function buttons for configuring and monitoring the network elements. When the operator selects, e.g., the "Network Provision" function in Figure 6 (c), a sub-window (Figure 6 (d)) shows the graphical configuration of the selected ATM switch. In this sub-window, two rectangles depicted on the left and right sides represent two ATM ports. The operator may configure an ATM cross-connect circuit by bridging these two ATM ports and setting up the QoS parameters for this connection.

2.2. Network Degradation Detection and Diagnostics

TOSS-N detects if the network performance is degraded to assure overall service quality and customer satisfaction. If performance degradation or fault event is detected when a customer is watching an IPTV channel, the

network automatically alarms the A&TM (Figure 2 (o)) through the NEA (Figure 2 (q)). For example, if an STB detects that its packet loss is greater than a threshold, it sends a *Threshold Crossing Alert* (TCA) SNMP trap to TOSS-N. Upon receipt of this TCA, the A&TM issues an *event ticket* to the SPM of TOSS-T to organize an end-to-end test plan (e.g., a number of ICMP pings) to determine the root cause of the service degradation (details of the SPM are elaborated in Section 5.2). If necessary, the SPM may request the NT&D to perform a number of network tests (e.g., reset of the STB) to fix the network fault.

An event ticket can be at one of the following three states: **opened**, **acknowledged**, and **closed**. When a fault is detected at a network element, an event ticket with the **opened** state is created by the A&TM. The operator uses the TOSS-N management portal to manually change an opened ticket to the **acknowledged** state if the operator will handle it. An acknowledged ticket becomes closed when the associated network fault is resolved. A ticket is marked as "minor" or "major" according to its severity. For example, a ticket of major severity can be "a port of the ATM switch was broken". This ticket will be set to the **closed** state when the ATM port resumes operation or when the operator shuts down the broken ATM port manually.

2.3. Network Performance Analysis

The NSPA (Figure 2 (n)) periodically collects performance data (e.g., packet loss of an STB) to generate a series of statistical performance analysis reports. For example, in an IPTV packet loss analysis report for a group of STBs, every entry represents the number of lost packets per hour collected from the STB at a particular customer site. The report also includes the packet-loss threshold, and the IPTV service is not acceptable when the number of lost packets in that hour is greater than the threshold. When TOSS-Q requests TOSS-N to retrieve, e.g., packet loss statistics of an STB for service quality analysis, the NSPA will return this report to TOSS-Q.

3. TROUBLE HANDLING AND RESOLUTION (TOSS-T)

TOSS-T implements *Problem Handling* (Figure 1 (6)) and *Service Problem Management* in eTOM (Figure 1 (9)). Through two components *Trouble Handling &*

Dispatching (THD; Figure 2 (h)) and Service Problem Management (SPM; Figure 2 (i)), TOSS-T provides problem handling and resolution functions such as trouble ticket creation, problem diagnosing, activities dispatching, problem resolving, and activity tracking/reporting.

3.1. Trouble Handling and Dispatching

The Trouble Handling and Dispatching (THD) receives trouble reports from customers, and is responsible for managing the recovery activities, fixing customer problems, and providing status of the activities. Specifically, the THD performs trouble report creation, activity dispatching, activity tracking, history reporting, and report sharing. The details are given below.

3.1.1. Trouble Report Creation

When the THD receives a customer problem, it creates a *trouble report*. This customer problem can be an event ticket (such as “performance degradation of a device”) from TOSS-N, or a customer complaint issued from the CSR. For the IPTV service, the THD has defined more than 30 trouble codes to describe various trouble situations. For examples, code Z61 represents the complaint “No available IPTV channels”, code Z11 means “Can’t connect to server”, and Z71 means “Can’t subscribe to video clip”.

An IPTV trouble report can be created through the THD web page, which includes customer’s IPTV service number, reported IPTV trouble code, customer’s contact information and the appointed time of a visit for, e.g., STB replacement.

3.1.2. Activity Dispatching

A problem is resolved by carrying out several *activities*. An activity can be problem isolation/diagnosis, resource maintenance, cable/device repair, customer’s equipment replacement, and so on. Each activity is assigned to an appropriate operator for execution. After the operator finishes this activity, a *result code* is returned to the THD. This result code concludes the execution of the activity. The subsequent activity is dispatched by the THD based on the result code of the previous activity. To do so, the THD relates every trouble code/result code to a dispatch rule. Depending on device type, operator’s workload, customer’s address and other factors, the dispatch rule defines appropriate operators to handle specific activity types. In the previous example, after an IPTV trouble report was created with trouble code Z61 “No available IPTV channels” (Figure 7 (a)), the THD applies the corresponding dispatch rule (Figure 7 (b)) to select an operator in IPTV operation center and dispatches “diagnose” activity (Figure 7 (c)) to him/her to identify the cause of this problem. The operator isolates the problem by using the SPM functions. If the diagnosis indicates an STB failure, the result code is ZC1 “STB is unavailable” (Figure 7 (d)). Based on this result code, the THD applies the dispatch rule “Duty of Office” (Figure 7 (e)) to assign an appropriate field operator (the rule option is “Field Maintenance”) to carry out the “Repair” activity (Figure 7 (f)). The field operator then makes a visit to the customer for STB replacement.

Dispatch Rule of diagnose Activity [Service: Telephone & ADSL & IPTV]			
Trouble Code/Result code	Rule Type	Rule Option	Activity Type
T DC-Disconnect	Duty of Office	Measure Unit	Diagnose
T Z61-No available IPTV channels	Specific Unit	IPTV Operation Center	Diagnose
T Z62-Some IPTV channels are not available	Specific Unit	IPTV Operation Center	Diagnose
T Z63-Can't view video clip	Specific Unit	IPTV Operation Center	Diagnose
T Z71-Can't subscribe video clip	Specific Unit	IPTV Operation Center	Diagnose
P YOK-Service test result is OK	Specific Rule	CSR	Confirm
R ZC1-STB is unavailable	Duty of Office	Field maintenance	Repair
R ZC2-Remote control problem	Duty of Office	Field maintenance	Repair
R ZH1-HPER configuration problem	Duty of Office	HPER maintenance	Repair
R ZH2-HPER Trunk port problem	Duty of Office	HPER maintenance	Repair
R NST-No video stream	Specific Unit	IPTV Operation Center	Repair
R LSF-Live TV Sserver problem	Specific Unit	IPTV Operation Center	Repair
R CFM-Confirm with customer	Specific Rule	CSR	Confirm
R END-Report Close	Specific Rule	Report Close	Close

Figure 7. An example of IPTV activity dispatching

3.1.3. Activity Tracking, History Reporting, and Report Sharing

The THD monitors all activities of a customer problem to ensure that they are assigned, coordinated and tracked. The THD also records the execution result of an activity in the trouble report. After a problem is resolved, the THD closes the trouble report and notifies the CSR. The operator will contact the customer to ensure that the resolution is satisfied. Based on the trouble report, the THD also generates the statistics for problem analysis and operator workload for future usage. The THD shares the trouble report and the progress of problem resolving with other subsystems such as TOSS-Q. The shared information is presented in the NGOSS SID-based XML format [9].

3.2. Service Problem Management

To support an operator who diagnoses a service problem, the Service Problem Management (SPM) offers service problem management through service testing and service impact analysis.

The SPM interacts with TOSS-N to provide testing functions including physical layer link testing, data-link layer testing and IP layer testing. For example, when an operator in IPTV operation center receives a diagnosis activity from the THD, he/she will utilize the SPM to carry out the following IPTV service tests:

- Access network tests check DSLAM, Layer 2 and Layer 3 switches. The test functions include loopback test, traffic diverge query, VTU-R query, GESW port query, and so on.
- Core network tests check ATM switch routers and *Broadband Remote Access Servers* (BRAS). The test functions include *High Performance Edge Router* (HPER) query, VLAN traffic query, the connectivity test between HPER and BRAS, and so on.
- Service platform tests include service platform configuration query, user action query, service lock/unlock, and so on.
- End-user device tests include STB reset, STB firmware update, STB status query, and so on.

Through above tests, the SPM assists an operator to identify the root causes of a trouble, and the result is fed back to the THD.

The SPM also performs service impact analysis when it receives event tickets (e.g., network degradation detection) from TOSS-N.

The SPM analyzes these event tickets to determine which services are involved, and identifies the customers impacted by these events. The SPM then sends the analysis result to the THD to create a trouble report for problem resolving.

4. QUALITY ASSURANCE MANAGEMENT (TOSS-Q)

Through *Service Quality Management* (SQM; Figure 2 (j)) and *Customer Quality Management* (CQM; Figure 2 (k)), TOSS-Q supports quality assurance management by monitoring network element availability, identifying network bottlenecks, and correlating alarms to detect potential problems.

4.1. Service Quality Management

The Service Quality Management (SQM) specifies the levels of services delivered to customers. For example, the service availability of the golden level IP-Virtual Private Network (IP-VPN) Service is 99% and the availability of the platinum level is up to 99.95%. The SQM also predicts service degradation or network problems on specific customers. The SQM implements three functions described in the following subsections.

4.1.1. Network Performance Monitoring

The SQM collects performance data from various systems and presents these data as *key performance indicators* (KPIs) that allow an operator to quickly recognize the service status of a business department (a set of customer sites that are geographically nearby). Examples of IPTV KPIs are zap time and IPTV server connection time calculated by the *Performance Evaluation and Testing System* (PETS; to be elaborated later). The SQM defines three status levels for a KPI (i.e., green for normal, yellow for warning and red for critical). For warning and critical KPIs, the SQM issues notifications to appropriate operators. For example, Figure 8 illustrates the traffic overload KPI of IPTV service. In this example, the STBs in the business department PCPC (Pan-Chiao area; Figure 8 (a)) receive video streams from a L3 switch PCPC-212 (Figure 8 (b)). Suppose that the customers in PCPC area try to access IPTV channels many times without success. These heavily repeated actions result in large traffic to PCPC-212, and therefore the traffic overload KPIs in Figure 8 (a) and (b) are marked yellow.

Figure 8 (c) illustrates two video servers PCPC-TV5-402 and PCPC-TV5-403 in the IPTV service platform. These servers connect to the L3 switch PCPC-212. Assuming that some TV channels are lost in each of the video servers, and therefore these servers are marked red (and that is why the customers fail to access the TV channels). The above abnormal situation results in a trouble ticket generated for PCPC (Figure 8 (d)). Notation (1:0) means that there is one ADSL trouble ticket and no leased-line trouble ticket. The trouble ticket suggests that an appropriate operator be dispatched to fix the problems of the video servers. After the problems are fixed, the red/yellow KPIs will turn green again.

4.1.2. Service Testing

The SQM implements the *Performance Evaluation and Testing System* (PETS) to measure the service quality, and detect the problems before the customers are aware of them. The PETS contains many *Remote Test Units* (RTUs) and a *Test Center* (TC). An RTU (Figure 9 (a)) is installed at a central office to

emulate the STB at a customer site. The RTU automatically executes test cases that emulate customer behaviors such as downloading a file from the Internet, selecting IPTV channels and watching IPTV programs. The TC server (Figure 9 (b)) periodically collects the test results from the RTUs. If a potential problem (such as failure for IPTV channel selection) is detected, the SQM will notify appropriate operators to confirm the problems, and repair malfunctioned network elements or software configurations. There are about 600 RTUs in Chunghwa Telecom's central offices, which execute various tests every two minutes to identify potential problems and service quality degradation. A major advantage of the RTU/TC approach is that it is proactively detect the service problems without involving STBs at the customer sites.

The RTU test results are sent to the TC to generate a statistics report that provides, for example, the failure history in the last ten days. This report indicates when failures were detected. An operator may check the test results of a particular time period in this report.

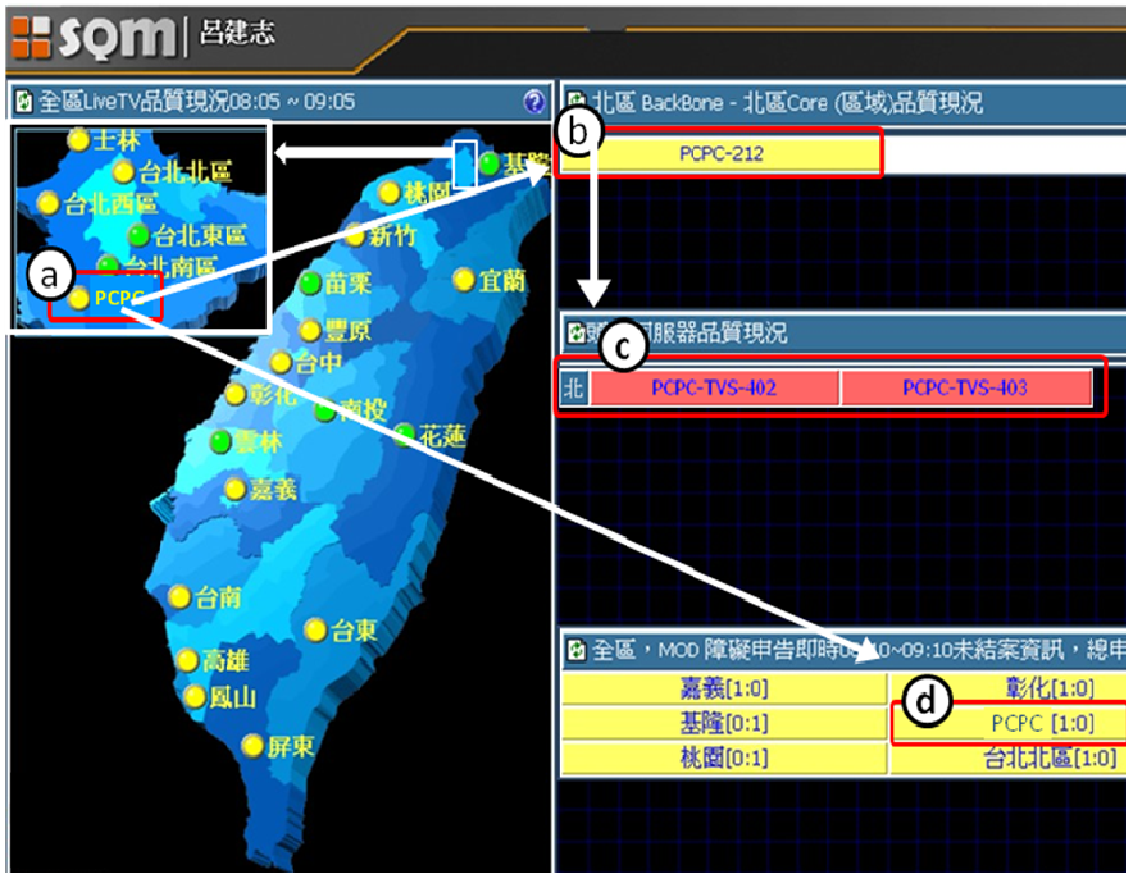

Figure 8. The SQM monitoring web page for IPTV

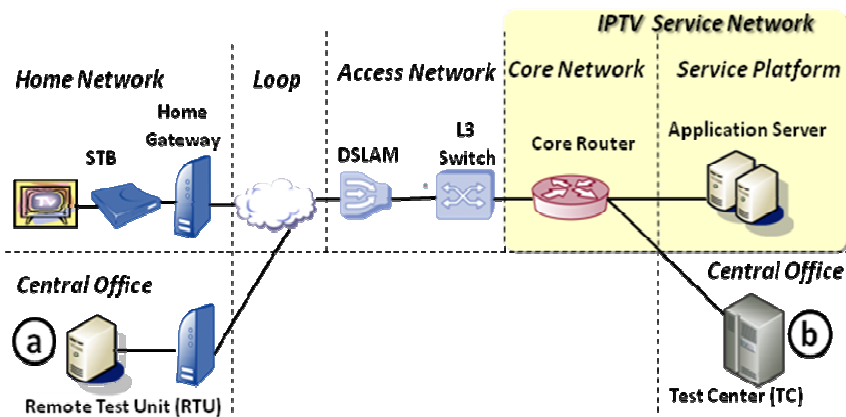

Figure 9. The RTU and TC configuration

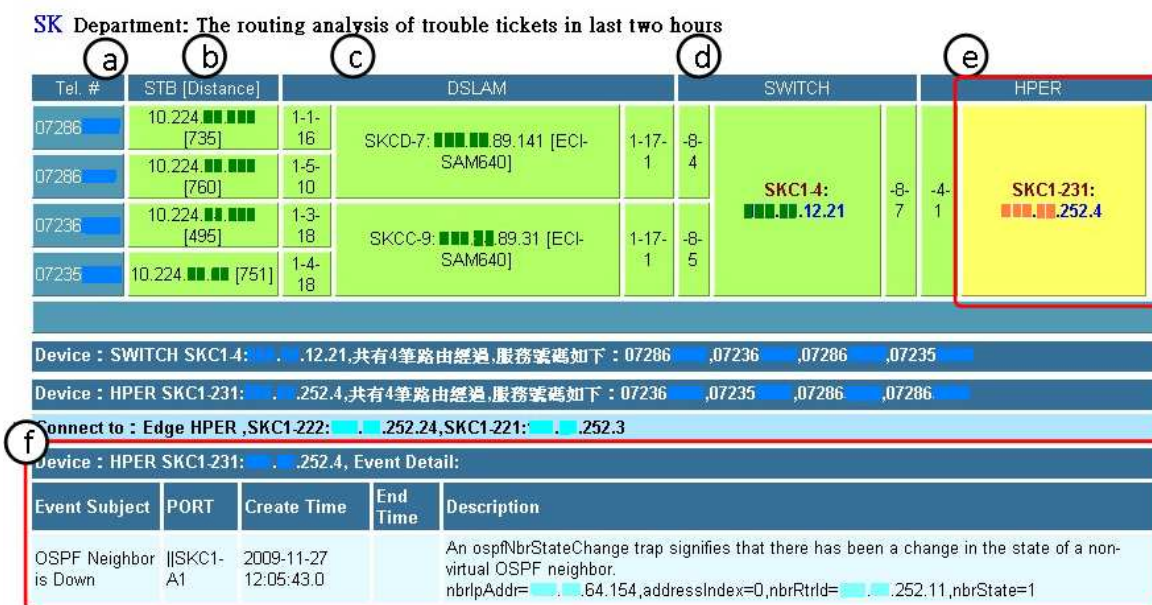

Figure 10. The SQM notification message

4.1.3. Service Degradation Detection & Diagnostics

According to performance data and event tickets generated from TOSS-N, trouble tickets generated from TOSS-T, or test results generated from the PETS, the SQM can conduct service degradation detection and diagnostics. For example, the SQM periodically counts the number of trouble tickets created in every two hours, and if necessary, sends a notification to alert an operator through short message or email (shown in Figure 10). In this message, the SQM groups the related tickets by tracing the route of network elements from the service platform to the customer locations of corresponding phone numbers shown in these tickets (Figure 10 (a)). In our example, four

tickets relate to the same switch SKC1-231 (Figure 10 (e)) although the phone numbers are assigned to different STBs (Figure 10 (b)) connecting to different DSLAMs (Figure 10 (c)). The SQM also detects that an alarm (Figure 10 (f)) occurred in SKC1-231. Therefore, it concludes that SKC1-231 is the potential source of the problem indicated by these trouble tickets.

4.2. Customer Quality Management

The Customer Quality Management (CQM) implements an Internet portal for enterprises or customers with SLA contracts to perform quality assurance functions by themselves. This portal consists of two CQM functions to be described in the following subsections.

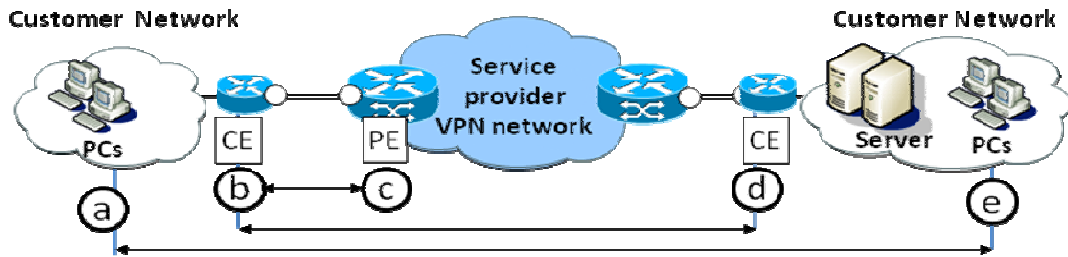

Figure 11. Measurement points of a VPN architecture

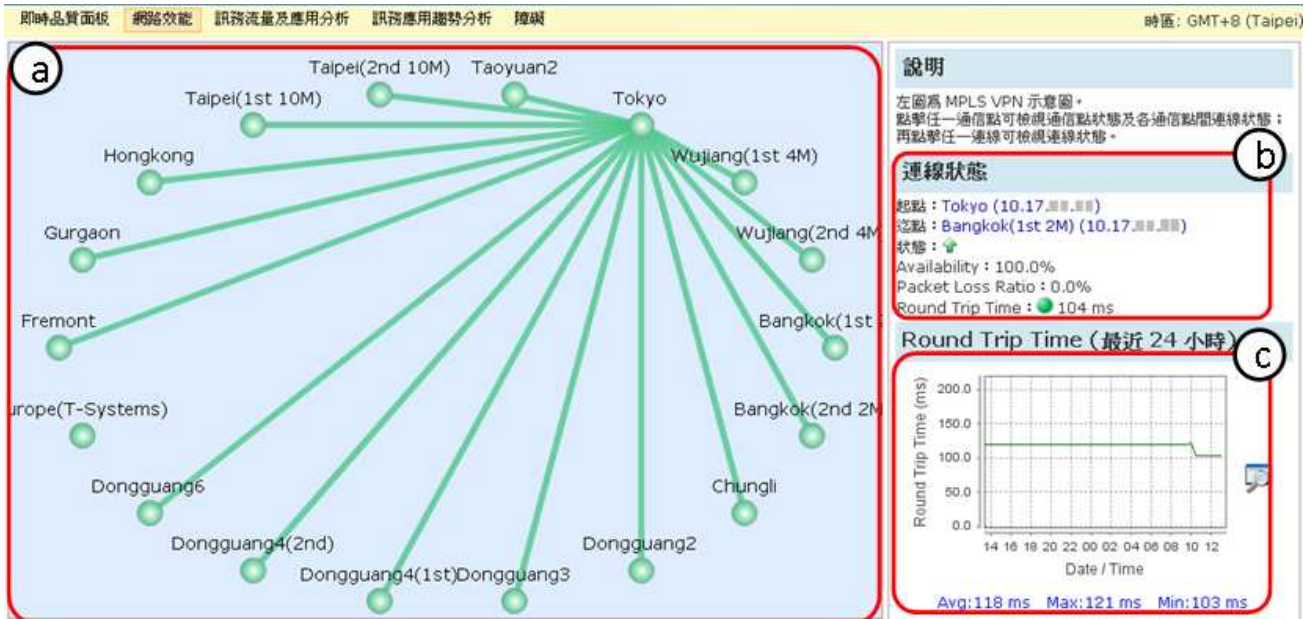

Figure 12. The CQM monitoring window for IP-VPN performance

4.2.1. Service Performance Monitoring

Similar to the SQM, the CQM monitors network status through TOSS-N. Network elements monitored by the CQM are either located in service provider's central offices or at customer sites. For example, an IP-VPN customer can use the CQM to measure network performance (such as round trip delay, packet loss, throughput, and so on) in different time periods according to the SLA contract. The CQM provides the round trip delay between the *Provider Edge* routers (PEs; Figure 11 (c)) located in the central offices and the *Customer Edge* routers (CEs; Figure 11 (b) and (d)) located at the customer sites. The CQM can also directly retrieve the throughput data recorded at the PEs. Furthermore, if a pair of CEs (Figure 11 (b) and (d)) is managed by TOSS-N, the CQM can also provide the end-to-end packet delay statistics.

Figure 12 (a) illustrates the IP-VPN topology of an enterprise in the CQM web page. When a

user clicks, for example, the line between Tokyo and Bangkok (1st), it shows the round trip time and packet loss in last five minutes (Figure 12 (b)) and the delay statistics in the last 24 hours (Figure 12 (c)).

4.2.2. SLA Reports and Traffic Analysis Reports

The CQM generates SLA reports for, e.g., availability. The availability report summarizes the availability measurements of a specific site including total up time, total disconnect time and so on.

In Figure 11, the CQM fully monitors the service provider network (from Figure 11 (b) to (d)), but may not be able to access the devices (e.g., web/ERP/video servers) in the customer networks (Figure 11 (a) and (e)). Through tools such as NetFlow [10], the CQM can analyze the statistics (e.g., utilization of a web server at the customer network; see Figure 11 (e)) by

parsing the data flow received by the CE router in Figure 11 (d). A data flow is a unidirectional stream of packets between a given source and destination pair, which is identified by source/destination IP address/port number, Layer 3 protocol type, type-of-service byte and input logical interface. CQM can show, for example, the top 10 sites of the highest TCP/IP traffic in customer networks, and provide the detailed information including the IP address/port number, precedence and traffic in KBytes. Currently, Chunghwa Telecom's CQM monitors up to 15 million data flows every day and the number of flows is continuously increasing by days.

五、 結果與討論

Based on eTOM, this study presents TOSS, a practical approach to the development and integration of four OSS groups (i.e., TOSS-P, TOSS-N, TOSS-T, and TOSS-Q). The functionalities of TOSS and the associated operation scenarios related to IPTV and IP-VPN service fulfillment and assurance are described. From the viewpoint of functional categorization, TOSS provides customer-centric operations models regarding automated service provisioning, integrated network management, proactive trouble handling, and end-to-end quality assurance to enhance customer experience. From the viewpoint of managed broadband network, TOSS provides full coverage of inventory, fault, and performance management of end-user devices, access network, core network, and service platforms. TOSS has been successfully applied by Chunghwa Telecom to support daily operations of various fixed-line and wireless services such as xDSL/FTTx, IPTV, IP-VPN, VoIP, FMC, 3G/3.5G [11], and new innovating ICT services such as telematics and energy saving services.

The financial report disclosed by Chunghwa Telecom revealed that the operational efficiency is achieved since TOSS assists to reduce the OPEX (e.g., manpower saving) by streamlining business operation processes and helps generate revenue by providing the functions for managing new services timely. Consider IPTV service as an example, 99.81% of service orders can be fulfilled within one day. The number of IPTV subscriptions in year 2008 was 172% of that in year 2007. The ratio of IPTV service trouble in Dec. 2009 was less than 1%, and the number of complaint calls for IPTV service in Dec. 2009 was 84% of that in

Dec. 2008. For broadband access service, the average access bandwidth per user in year 2008 was 162% of that in year 2007. The number of FTTx subscriptions in year 2008 was 200% of that in year 2007. Specifically, TOSS-N manages more than 160 models of broadband network elements provided by 45 vendors. 885.26 thousand broadband network elements were managed by TOSS-N for year 2009. This amount was 162% of that in year 2008 and 731% of that in year 2007. 20.35 million automatic network activations of broadband services were performed by TOSS-P and TOSS-N in year 2009. This amount was 102% of that in year 2008, and was equivalent to a saving of 465 manpower per year. 135.8 million network testing and diagnostics commands of broadband services were carried out by TOSS-T, TOSS-Q, and TOSS-N in year 2009. This amount was 177% of that in year 2008, and was equivalent to a saving of 1241 manpower per year. From the commercial operations, our experiences indicate that TOSS achieves the goals of self-care, customization, complex bundling, and end-to-end quality guarantee.

ABBREVIATIONS

ATM: Asynchronous Transfer Mode
A&TM : Alarm & Ticket Management
BRAS: Broadband Remote Access Server
CE: Customer Edge Router
CFS : Customer Facing Service
CQM: Customer Quality Management
CRM : Customer Relationship Management
CSR : Customer Service Representatives
DSL: Digital Subscriber Line
DSLAM: DSL Access Multiplexer
FAB: Fulfillment, Assurance, Billing
FNPA : Flow-through Network Provisioning & Activation
FSM : Finite State Machine
FTTx: Fiber to the x
GESW: Giga-bit Ethernet Switch
HDTV: High Definition TV
HPER: High Performance Edge Router
ICT: Information and Communication Technology
IPTV: Internet Protocol Television
IT: Information Technology
JMS: Java Message Service
KPI: Key Performance Indicator
MOD: Multimedia on Demand
MSAN: Multi-Service Access Node
NEA : Network Element Adapter
NSPA: Network Status & Performance

Analysis
 NT&D: Network Test & Diagnosis
 OHM: Order Handling Management
 OM: Order Manager
 OPEX: Operating Expenditure
 OPS: Operations
 OSR: Operation Support & Readiness
 OSS: Operations Support System
 PCPC: Pan-Chiao area
 PETS: Performance Evaluation and Testing System
 PSTN: Public Switched Telephone Network
 QoS: Quality of Service
 RM : Request Manager
 RTU: Remote Test Unit
 SAI: Service Activation Interface
 SC : Service Component
 SCM: Service Component Manager
 SDTV: Standard Definition TV
 SI&P: Strategy, Infrastructure & Product
 SLA: Service Level Agreement
 SNMP: Simple Network Management Protocol
 SOA: Service-Oriented Architecture
 SPM: Service Problem Management
 S/PRM: Supplier/Partner Relationship Management
 SQM: Service Quality Management
 STB: Set-top Box
 StM: State Manager
 TC: Test Center
 TCA: Threshold Crossing Alert
 THD: Trouble Handling & Dispatching
 TOSS: Telecom Operations Support System
 VPN: Virtual Private Network
 VTU-R: VDSL Transceiver Unit - Remote Terminal
 xDSL: x Digital Subscriber Line

六、 成果自評

(一) 對於學術研究、國家發展及其他應用方面預期之貢獻：

1. 論文發表：本計畫之學術成果包括：
 - a. Lee, H.-Y. and Lin, Y.-B. Credit Pre-reservation Mechanism for UMTS Prepaid Service. IEEE Transactions on Wireless Communications, 9(6): 1867 – 1873, 2010.
 - b. Chen, Y.-K., Lin, Y.-B., et al., TOSS: Telecom Operations Support Systems

for Broadband Services. To appear in Journal of Information Processing Systems

c. Lin, Y.-B., Liou, R.-H., Chen, Y.-K., and Gan , C.-H. A Handset-based Solution for Reducing International Roaming Costs, IEEE Transactions on Wireless Communications, 10(5): 1627 – 1635, 2011.

2. 效能評量：利用電信營運系統之效能評量模組監測電信服務效能及客戶端服務品質。

(二) 對於參與之工作人員，預期可獲之訓練：

1. 整合型電信應用服務之營運系統設計。
2. 電信營運系統之效能評量方法。

七、 參考文獻

- [1] TM Forum, New Generation Operations Systems and Software (NGOSS), TM Forum, 2009.
- [2] TM Forum, Business Process Framework-enhanced Telecom Operations Map (GB921), R8.0, TM Forum, 2009.
- [3] Y.-B. Lin and S.-I. Sou. Charging for Mobile All-IP Telecommunications. John Wiley and Sons, 2008.
- [4] Multimedia on Demand (MOD), <http://www.cht.com.tw/>.
- [5] TM Forum. Multi-Technology Operation Systems Interface (MTOSI) Solution Suite Release 2.0 Service Activation, TM Forum, 2009.
- [6] T. Erl. Service-Oriented Architecture (SOA): Concepts, Technology, and Design, Prentice Hall, 2005.
- [7] C. H. Hu and S. H. Hsu. “SOA-based Alarm Integration for Multi-Technology Network Fault Management,” IEEE Symposium on Service-Oriented System Engineering, Taiwan, Dec. 2008, pp. 221-226.
- [8] Broadband Forum, “TR-069 CPE WAN Management Protocol,” www.broadband-forum.org/technical/.../TR-069_Amendment-2.pdf, Broadband Forum, Dec. 2007.

[9] TM Forum, Shared Information/Data (SID) Model – Business View Concepts, Principles, and Domains (GB922), R8.0, TM Forum, 2009.

[10] Cisco IOS Flexible NetFlow Technology White Paper.

[11] Y.-B. Lin and A.-C. Pang. Wireless and Mobile All-IP Networks, Wiley, 2005.