



US008480063B2

(12) **United States Patent**  
**Tsai**

(10) **Patent No.:** **US 8,480,063 B2**  
(45) **Date of Patent:** **Jul. 9, 2013**

(54) **WETTED WALL VENTURI SCRUBBER WITH A 2-STAGE VENTURI THROAT**

(75) Inventor: **Chuen-Jinn Tsai**, Hsinchu County (TW)

(73) Assignee: **National Chiao Tung University**, Hsinchu (TW)

(\*) Notice: Subject to any disclaimer, the term of this patent is extended or adjusted under 35 U.S.C. 154(b) by 473 days.

(21) Appl. No.: **12/662,899**

(22) Filed: **May 11, 2010**

(65) **Prior Publication Data**

US 2011/0057335 A1 Mar. 10, 2011

(30) **Foreign Application Priority Data**

Sep. 7, 2009 (TW) ..... 98130125 A

(51) **Int. Cl.**  
**B01F 3/04** (2006.01)

(52) **U.S. Cl.**  
USPC ..... **261/116**; 261/DIG. 54; 96/275; 96/323

(58) **Field of Classification Search**  
USPC ..... 261/115, 116, 117, 118, DIG. 9, 261/DIG. 54; 96/275, 323  
See application file for complete search history.

(56) **References Cited**

**U.S. PATENT DOCUMENTS**

3,085,793 A *	4/1963	Pike et al. ....	261/112.1
3,112,352 A *	11/1963	Krantz .....	261/36.1
3,131,237 A *	4/1964	Collins, Jr. ....	261/153
3,138,441 A *	6/1964	Krantz .....	96/245
3,142,548 A *	7/1964	Krantz .....	95/24
3,517,485 A *	6/1970	Dell'Agnesse et al. ....	96/261

3,877,488 A *	4/1975	Baturay et al. ....	138/44
4,043,772 A *	8/1977	Lundy .....	
4,210,428 A *	7/1980	Schneider et al. ....	96/275
4,578,226 A *	3/1986	Adlhoeh et al. ....	261/71
5,061,408 A *	10/1991	Huning et al. ....	261/112.1
5,249,740 A *	10/1993	Serra Tosio et al. ....	236/44 A
5,336,284 A *	8/1994	Schiffner .....	
5,759,233 A *	6/1998	Schwab .....	95/8
6,719,829 B1	4/2004	Schwab .....	
7,273,513 B2	9/2007	Linga et al. ....	
2004/0207102 A1 *	10/2004	Sugimori et al. ....	261/112.1

**OTHER PUBLICATIONS**

Chuen-Jinn Tsai, Chia-Hung Lin, Yu-Min Wang, Cheng-Hsiung Hunag, Shou-Nan Li Zong-Xue Wu and Feng-Cai Wang, An Efficient Venturi Scrubber System to Remove Submicron . . . Mar. 2005.  
Cheng-Hsiung Huang, Chuen-Jinn Tsai, and Yu-Min Wang, Control Efficiency of Submicron Particles by an Efficient Venturi Scrubber System, Journal of Environmental . . . Apr. 2007.

\* cited by examiner

*Primary Examiner* — Charles Bushey

(74) *Attorney, Agent, or Firm* — Bacon & Thomas, PLLC

(57) **ABSTRACT**

A venturi scrubber which avoids clogging in the throat by dust particles is developed. The scrubber includes a venturi tube, two scrubbing fluid conduits and a storage tank. The venturi tube has a converging section, a diverging section and a throat section which is connected between the converging section and the diverging section. The scrubbing fluid conduit has a top end connected with the bottom end of the converging section of the venturi tube, and a bottom end extending into the storage tank. Thereby, scrubbing fluid can be guided directly into the storage tank without passing through the throat section. As a result, the clogging of dust particles on the converging section of the venturi throat can be minimized and the abnormal increase in the pressure drop of the air flow through the throat can also be avoided.

**13 Claims, 7 Drawing Sheets**

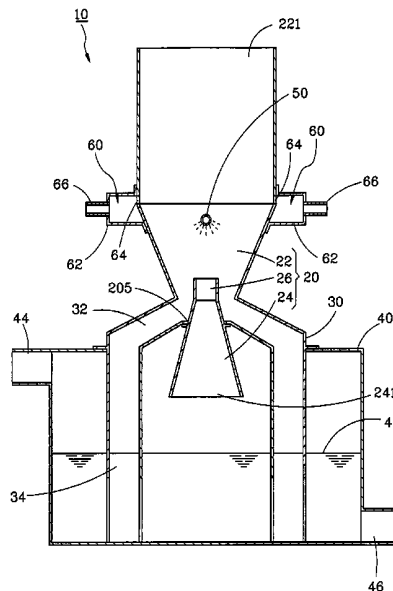

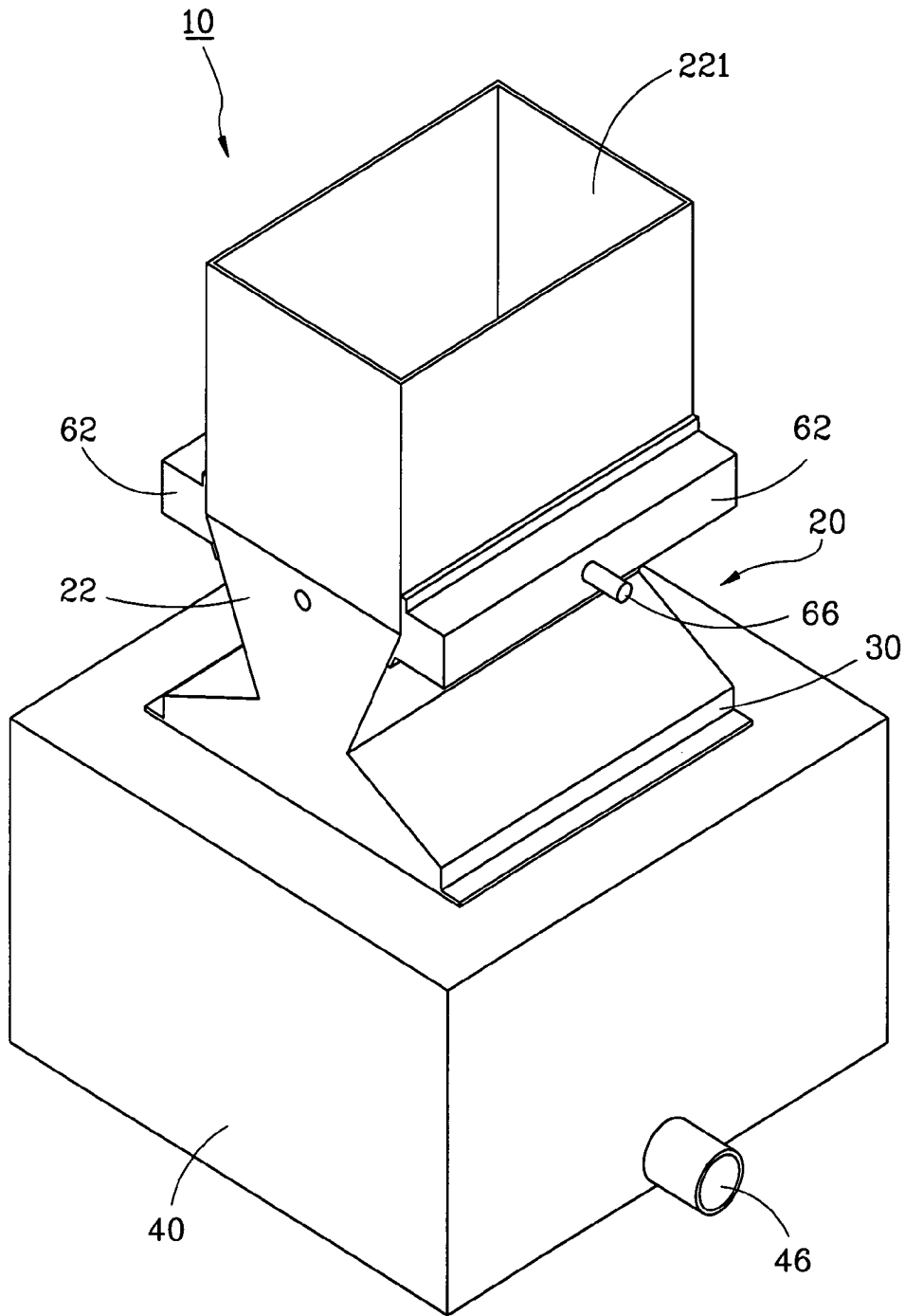
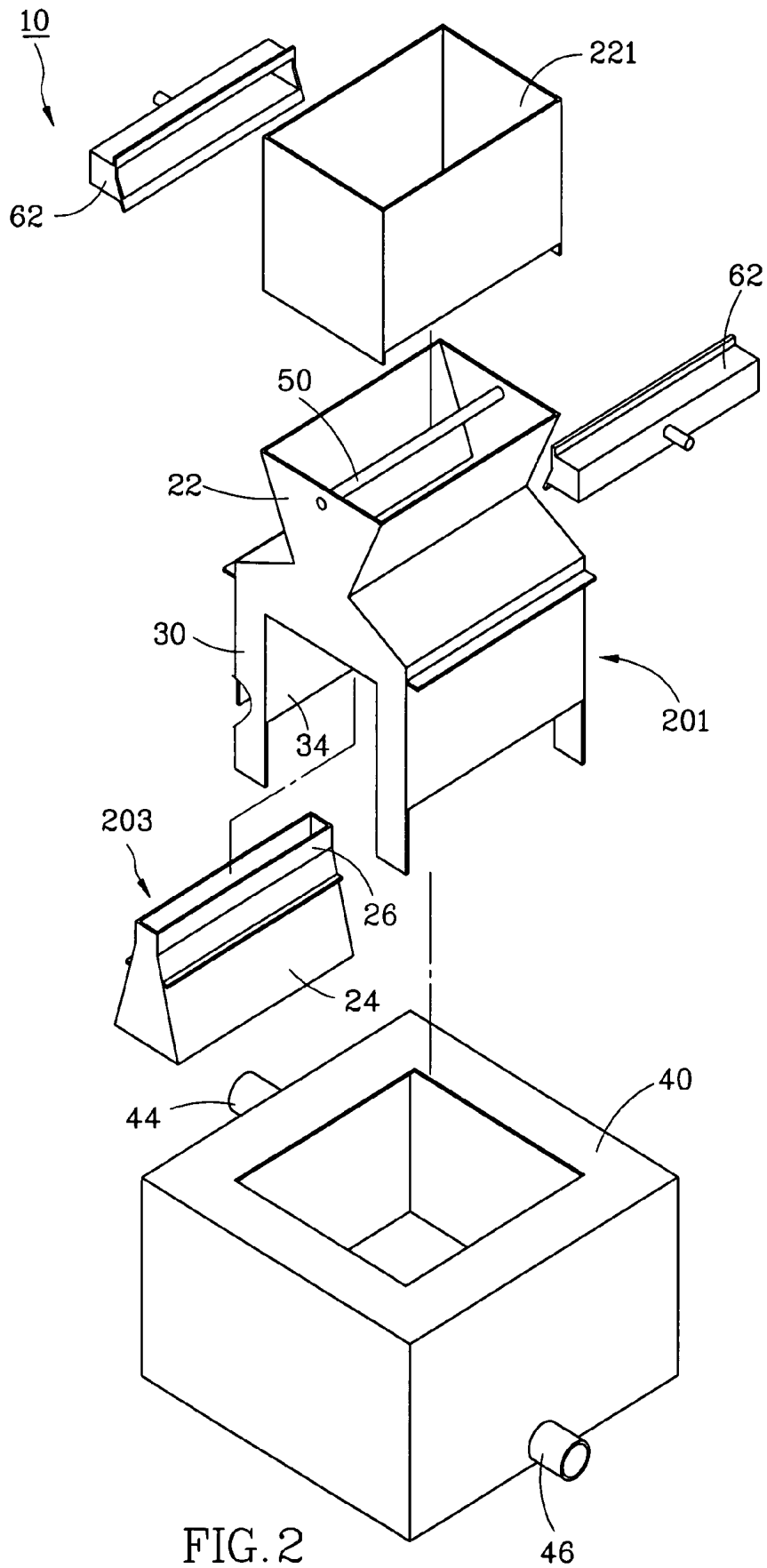

FIG. 1



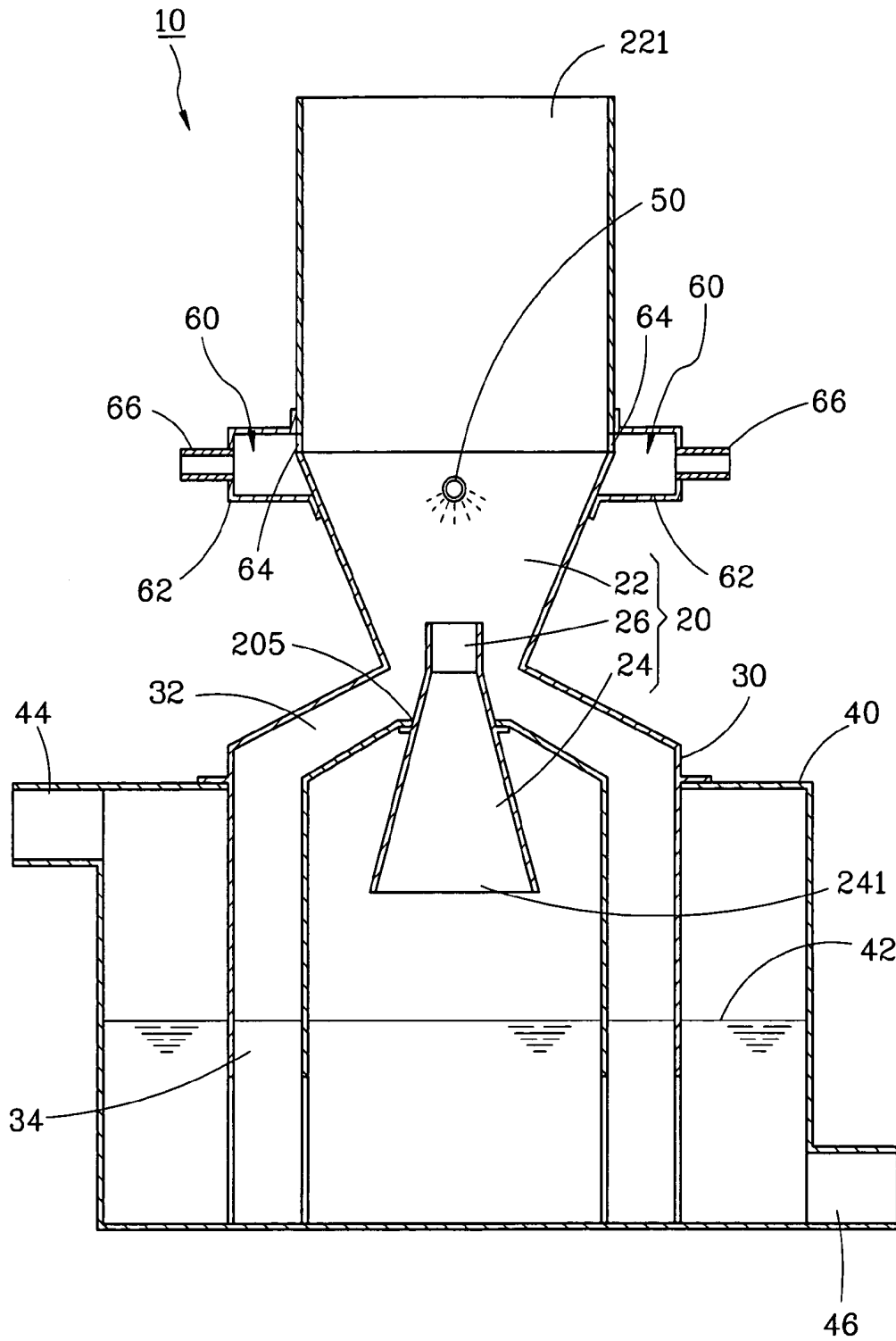

FIG. 3

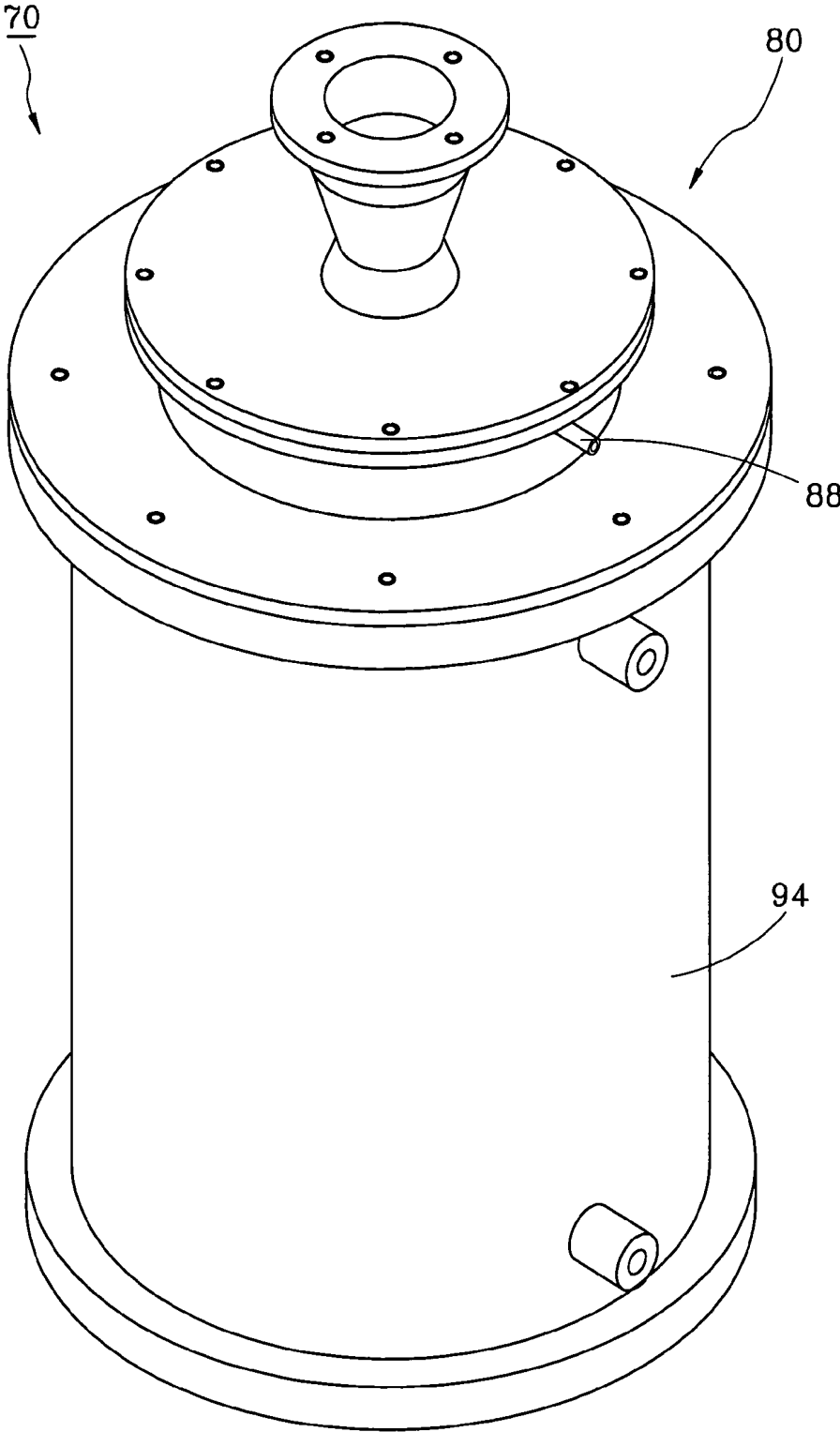

FIG. 4

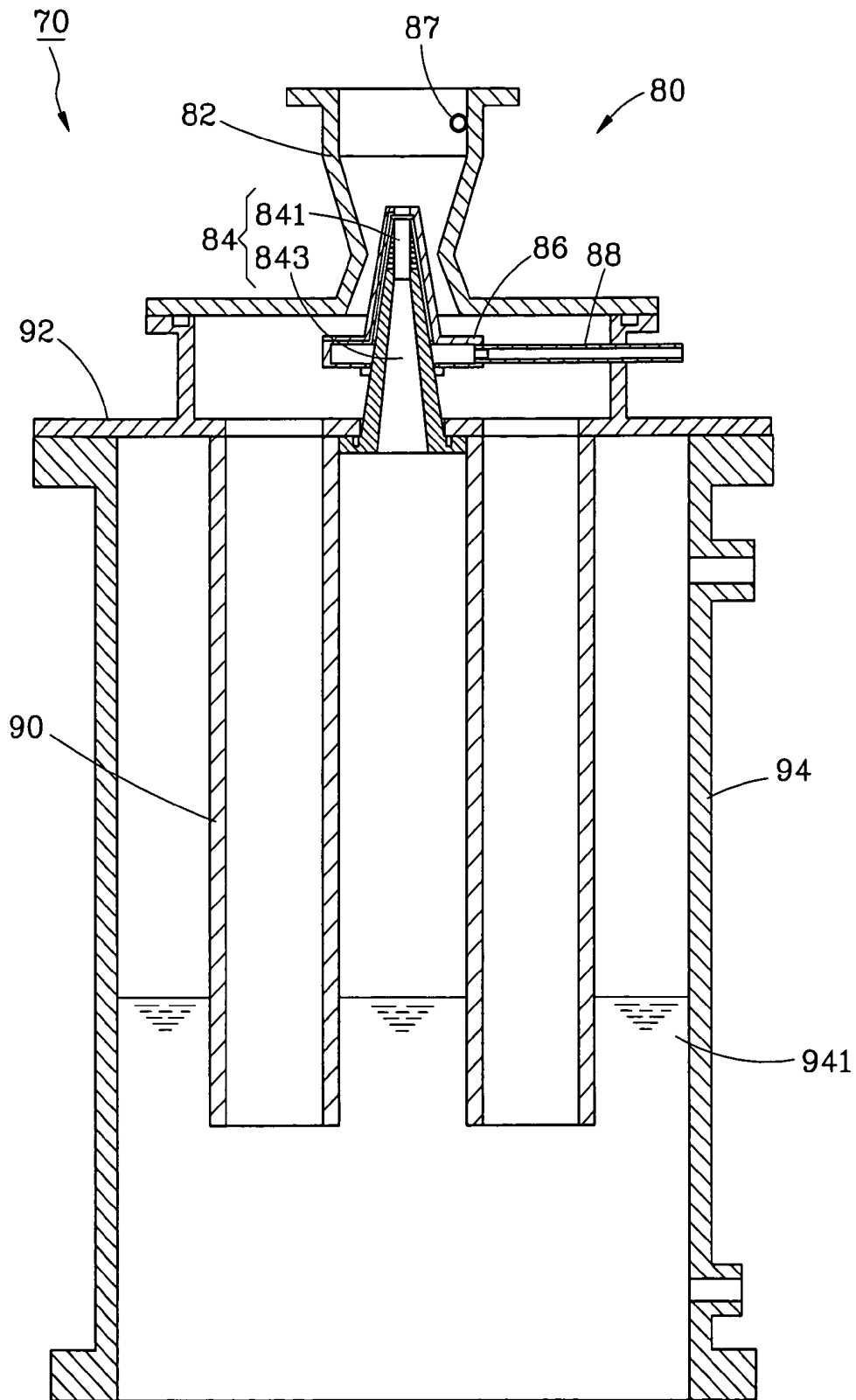

FIG. 5

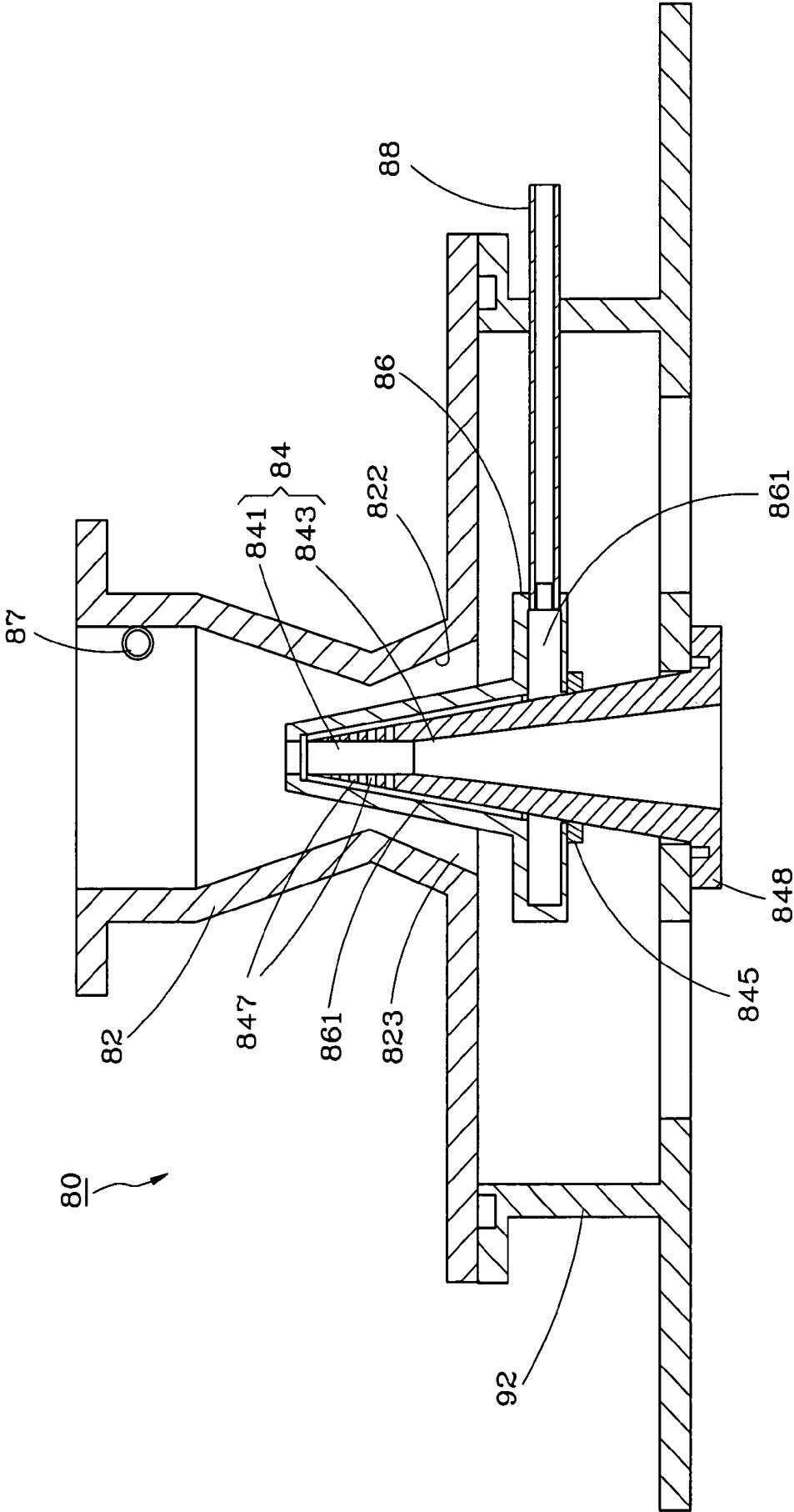

FIG. 6

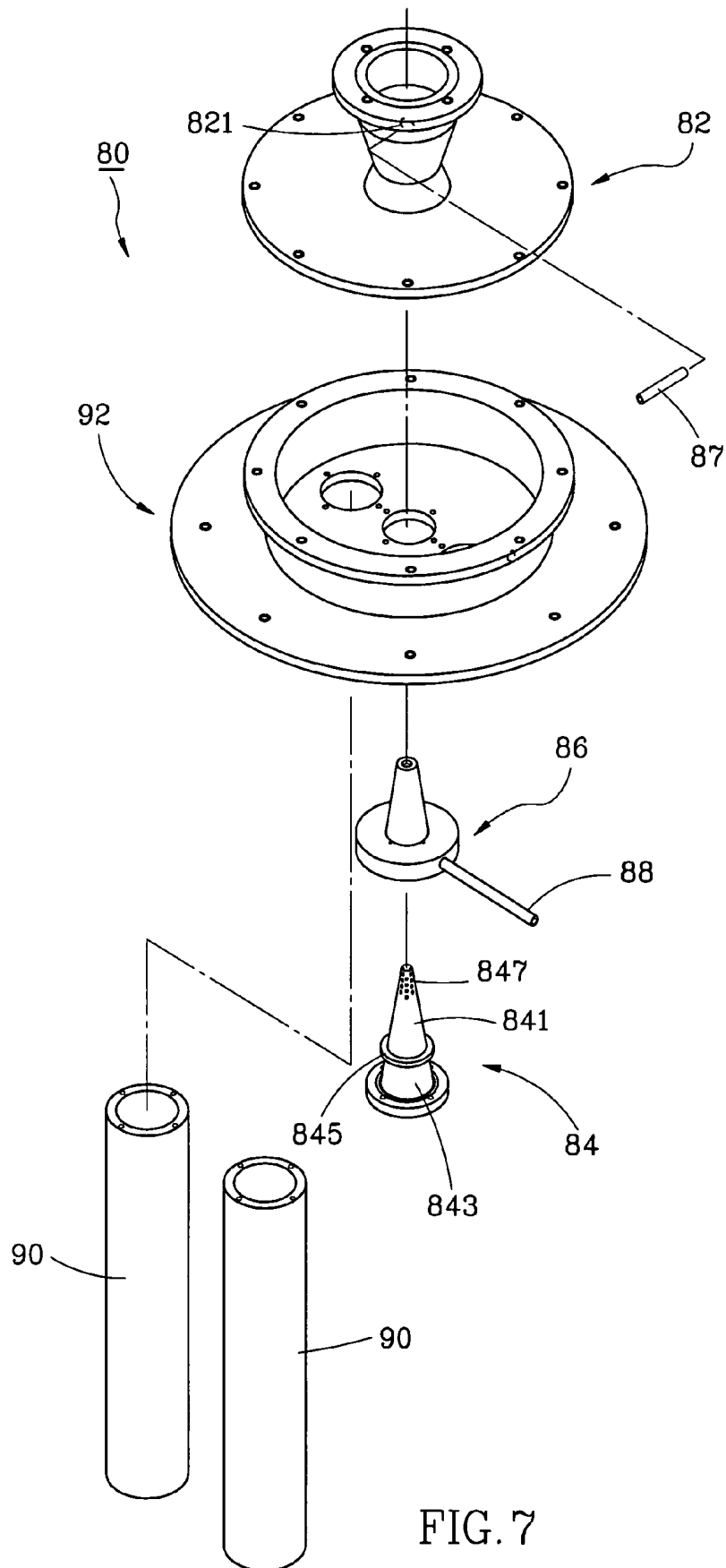

FIG. 7



## WETTED WALL VENTURI SCRUBBER WITH A 2-STAGE VENTURI THROAT

### BACKGROUND OF THE INVENTION

#### 1. Field of the Invention

The present invention relates to air pollution control equipment and more particularly, to a wetted wall venturi scrubber with a 2-stage venturi throat, which avoids clogging in the throat by dust particles.

#### 2. Description of the Related Art

Venturi scrubbers have been extensively used in the removal of particles in the waste gas. A traditional venturi scrubber generally comprises a converging section, a diverging section and a throat. The throat is connected between the converging section and the diverging section. Waste gas and scrubbing fluid droplets are introduced into the converging section, and then accelerated in the throat section. The scrubbing fluid droplets collide with the particles due to the velocity difference between the particles and the droplets, thereby causing the particles to collide with the droplets by inertial impaction and are removed from the waste gas.

However, when waste gas of high particle concentration is introduced into the venturi scrubber, the particles tend to be adhered to the inner surface of the converging section and the throat. Accumulation of particles results in particle clogging in the scrubber, thereby causing operation instability and abnormal increase in the pressure drop of the air flow through the scrubber. Further, the traditional venturi scrubber has a special shape comprising converging section, throat and diverging section, which complicates the fabrication process.

In the paper by Tsai et al. (*J. Air & Waste Manage. Assoc.*, 55: 319-235, 2005) and Huang et al. (*J. Environ. Eng. ASCE*, 133(4): 454-461, 2007), the particle collection efficiency of a traditional venturi scrubber was enhanced by condensational growth of fine particles before the scrubber. But the method to avoid particle clogging in the throat areas had never been mentioned. Both U.S. Pat. Nos. 5,336,284 and 4,043,772 disclose a venturi scrubber with an area-adjustable throat section. The users can change the throat cross sectional area according to the operating conditions. To avoid particle clogging, the throat cross sectional area can be increased while high-concentration aerosol particles are treated by the scrubber. But it will lead to the reduction of collection efficiency.

### SUMMARY OF THE INVENTION

It is the main objective of the present invention to provide a wetted wall venturi scrubber with a 2-stage venturi throat, which avoids clogging in the throat by dust particles.

Another objective of the present invention is to provide a wetted wall venturi scrubber with a 2-stage venturi throat, which reduces the manufacturing time, labor and cost.

To achieve these objectives, a wetted wall venturi scrubber designed with a 2-stage venturi throat comprises a venturi tube, a conduit and a storage tank. The venturi tube comprises a converging section, a diverging section and a throat connected between the converging section and the diverging section. The converging section comprises a gas inlet. The diverging section comprises a gas outlet. The conduit has its top end connected with the bottom side of the converging section. The storage tank is connected with the bottom end of the conduit. Further, the storage tank stores the scrubbing fluid. The bottom end of the conduit extends below the level of the scrubbing fluid in the storage tank. Further, the throat of the venturi tube has a top end extended to the inside of the converging section.

In one embodiment of the present invention, the wetted wall venturi scrubber further comprises an atomized sprayer mounted inside the converging section to form droplets which collect suspended particles in the throat by inertial impaction, and an overflow gutter connected with the converging section of the venturi tube to provide liquid flow that continuously washes off deposited particles in the converging section. The venturi tube and the conduit are formed of an outer component and an inner component. The converging section of the venturi tube and the conduit are formed in the outer component. The throat and the diverging section of the venturi tube are formed in the inner component. The outer component comprises a through hole for the insertion of one end of the inner component.

In another embodiment of the present invention, the venturi tube is formed of an outer component and an inner component. The converging section is formed in the outer component. The throat and the diverging section are formed in the inner component. The venturi tube further comprises a throat jacket sleeved onto the inner component and disposed inside the outer component. The throat jacket and the inner component define therebetween a scrubbing fluid inlet passage. The inner component of the venturi tube comprises a plurality of small holes on the wall of the throat. The holes are connected to the scrubbing fluid inlet passage. The inner component of the venturi tube comprises a rib extending around the periphery thereof and welded to a bottom side of the throat jacket. The conduit is connected with the outer component by a connecting member. The inner component is mounted inside the connecting member by a flange. The venturi tube comprises a wall-wetting fluid supply pipe connected with a top side of the converging section. The wall-wetting fluid supply pipe extends along the converging section in the tangential direction.

### BRIEF DESCRIPTION OF THE DRAWINGS

FIG. 1 is an isometric view of a wetted wall venturi scrubber with a 2-stage venturi throat in accordance with a first embodiment of the present invention.

FIG. 2 is an exploded view of the wetted wall venturi scrubber with a 2-stage venturi throat in accordance with the first embodiment of the present invention.

FIG. 3 is a sectional view of the wetted wall venturi scrubber with a 2-stage venturi throat in accordance with the first embodiment of the present invention.

FIG. 4 is an isometric view of a wetted wall venturi scrubber with a 2-stage venturi throat in accordance with a second embodiment of the present invention.

FIG. 5 is a sectional view of the wetted wall venturi scrubber with a 2-stage venturi throat in accordance with the second embodiment of the present invention.

FIG. 6 is a sectional view of the venturi tube of the wetted wall venturi scrubber with a 2-stage venturi throat in accordance with the second embodiment of the present invention.

FIG. 7 is an exploded view of the venturi tube and conduits of the venturi tube of the wetted wall venturi scrubber with a 2-stage venturi throat in accordance with the second embodiment of the present invention.

### DETAILED DESCRIPTION OF THE INVENTION

Referring to FIGS. 1-3, a wetted wall venturi scrubber with a 2-stage venturi throat 10 in accordance with a first embodiment of the present invention comprises a venturi tube 20, two scrubbing fluid conduits 30, a storage tank 40, an atomized sprayer 50 and two overflow gutters 60.

The venturi tube **20** comprises a converging section **22**, a diverging section **24** and a throat **26**. The throat **26** is connected between the converging section **22** and the diverging section **24** with its top end extended to the inside of the converging section **22**. The converging section **22** has a gas inlet **221** at its entry. The diverging section **24** has a gas outlet **241** formed in its one end remote from the throat **26**.

The two scrubbing fluid conduits **30** each have a top end **32** connected with the bottom side of the converging section **22** of the venturi tube **20**, and a bottom end **34** connected with the storage tank **40**.

The venturi tube **20** and the two scrubbing fluid conduits **30** are formed of an outer component **201** and an inner component **203**. The converging section **22** of the venturi tube **20** and the two scrubbing fluid conduits **30** are formed in the outer component **201**. The throat **26** and diverging section **24** of the venturi tube **20** are formed in the inner component **203**. The outer component **201** has a through hole **205** for the insertion of the top end of the inner component **203**.

The storage tank **40** is connected with the bottom side of the outer component **201** to collect the scrubbing fluid. The bottom end **34** of two scrubbing fluid conduits **30** extend below the fluid level of the scrubbing fluid, avoiding the waste gas directly passing through the two scrubbing fluid conduits **30** without scrubbing. The inside space of the storage tank **40** is in communication with the gas outlet **241** of the diverging section **24**. The storage tank **40** has an exhaust hole **44** and a scrubbing fluid outlet **46** respectively disposed in the top and bottom sides.

The atomized sprayer **50** is mounted inside the converging section **22** of the venturi tube **20** to spray fine droplets of scrubbing fluid.

The two overflow gutters **60** are formed by affixing two connectors **62** to the outside of the converging section **22**, each being in communication with the inside of the converging section **22** of the venturi tube **20** through an opening **64** on the converging section **22**.

The scrubbing fluid of the wetted wall venturi scrubber **10** is capable of washing particles from the waste gas directly and wetting the inner surface of the venturi tube **20**. The scrubbing fluid for washing particles is introduced into the venturi tube **20** through the atomized sprayer **50**. When the waste gas to be treated is guided through the gas inlet **221** into the converging section **22**, the fine droplets of scrubbing fluid generated by the atomized sprayer **50** is mixed with the waste gas to flow into the throat **26**. The fine droplets of scrubbing fluid collide with the particles in the waste gas, thereby causing dust particles to be removed from the waste gas. The purified gas is discharged through the exhaust hole **44** to the outside. After passing through the throat **26** and diverging section **24** of the venturi tube **20**, the scrubbing fluid flows into the storage tank **40**.

Further, the scrubbing fluid for wetting the inner surface of the venturi tube **20** is provided by the storage tank **40**. The scrubbing fluid is guided through a circulating piping (not shown) and two wall-wetting fluid supply pipes **66** to the two overflow gutters **60**, and then flows into the converging section **22** of the venturi tube **20** to wet its inside wall, avoiding adhesion and accumulation of dust particles. The overflowing scrubbing fluid then flows along the scrubbing fluid conduits **30** back to the storage tank **40**.

The scrubbing fluid for wetting the inside wall of the converging section **22** is directly guided back to the storage tank **40** by the scrubbing fluid conduits **30**, reducing the amount of scrubbing fluid passing through the throat **26**. It is helpful to avoid clogging in the throat **26** resulting from an over amount of the scrubbing fluid passing through the throat **26**.

As stated above, the venturi tube **20** and the two scrubbing fluid conduits **30** are formed by assembling an outer component **201** with an inner component **203**. So far as the configuration is concerned, the outer component **201** and the inner component **203** can be made much easier than a conventional venturi tube, decreasing much manufacturing time, labor and cost. Further, the top end of the throat **26** of the venturi tube **20** extends to the inside of the converging section **22**, facilitating the scrubbing fluid to flow into the scrubbing fluid conduits **30**.

Based on the spirit of the present invention, the structure of the venturi tube may be variously embodied. FIGS. 4~7 illustrate a wetted wall venturi scrubber with a 2-stage venturi throat **70** in accordance with a second embodiment of the present invention. Substantially similar to the aforesaid first embodiment, the wetted wall venturi scrubber with a 2-stage venturi throat **70** in accordance with this second embodiment comprises a venturi tube **80**, two scrubbing fluid conduits **90** and a storage tank **94**.

The venturi tube **80** is formed by connecting an outer component **82**, an inner component **84**, a throat jacket **86**, a wall-wetting fluid supply pipe **87** and a dust particle scrubbing fluid supply pipe **88** with one another. The outer component **82** is a cylindrical tube defining a converging section **82**. Further, the outer component **82** has a hole **821** near the top side of the converging section **82** for the insertion of the wall-wetting fluid supply pipe **87**. The wall-wetting fluid supply pipe **87** extends along the tangential direction so that the scrubbing fluid flows spirally along the inner surface of the converging section **82**. The outer component **82** further has a through hole **822** on the bottom side for the insertion of the inner component **84**. The inner component **84** defines a throat **841** and a diverging section **843**. Further, the inner component **84** has a rib **845** extending around the periphery. The throat **841** has a plurality of small radial holes **847**. The throat jacket **86** is sleeved onto the inner component **84** and disposed inside the outer component **82**, defining with the inner component **84** a scrubbing fluid inlet passage **861** that communicates with the outside through the dust particle scrubbing fluid supply pipe **88** and the inside of the inner component **84** through the small holes **847**. The bottom side of the throat jacket **86** is welded to the rib **845** of the inner component **84**.

The two scrubbing fluid conduits **90** are connected to the outer component **82** by a connecting member **92**. The inner component **84** is fixedly mounted inside the connecting member **92** by a flange **848**.

The scrubbing fluid **941** in the storage tank **94** is guided through a circulation piping (not shown) and the wall-wetting fluid supply pipe **87** into the converging section **82** of the venturi tube **80** to wet the inside wall of the converging section **82**. Thereafter, the scrubbing fluid flows through a scrubbing fluid outlet passage **823** between the outer component **82** and the throat jacket **86** into the inside of the connecting member **92**, and then through the scrubbing fluid conduits **90** into the storage tank **94**. Further, the scrubbing fluid after purification is guided through the dust particle scrubbing fluid supply pipe **88**, the scrubbing fluid inlet passage **861** and the small holes **847** into the throat **841** to wash dust particles from the waste gas.

Although particular embodiments of the invention have been described in detail for purposes of illustration, various modifications and enhancements may be made without departing from the spirit and scope of the invention. Accordingly, the invention is not to be limited except as by the appended claims.

5

What is claimed is:

1. A wetted wall venturi scrubber, comprising:
  - a venturi tube, said venturi tube comprising a converging section, a diverging section and a throat connected between said converging section and said diverging section, said converging section comprising a gas inlet, said diverging section comprising a gas outlet;
  - a conduit, said conduit having a top end connected with a bottom side of said converging section and a bottom end; and
  - a storage tank connected with the bottom end of said conduit for storage of scrubbing fluid, the conduit being adapted to guide the scrubbing fluid from the venturi tube to the storage tank.
2. The wetted wall venturi scrubber as claimed in claim 1, wherein said storage tank stores a scrubbing fluid; the bottom end of said conduit extends below the level of said scrubbing fluid in said storage tank.
3. The wetted wall venturi scrubber as claimed in claim 1, further comprising an atomized sprayer mounted inside said converging section of said venturi tube.
4. The wetted wall venturi scrubber as claimed in claim 1, further comprising an overflow gutter connected with said converging section of said venturi tube.
5. The wetted wall venturi scrubber as claimed in claim 1, wherein said throat of said venturi tube has a top end extended to the inside of said converging section.
6. The wetted wall venturi scrubber as claimed in claim 1, wherein said venturi tube and said conduit are formed of an outer component and an inner component; said converging section of said venturi tube and said conduit are formed in said outer component; said throat and said diverging section of said venturi tube are formed in said inner component; said

6

outer component comprises a through hole for the insertion of one end of said inner component.

7. The wetted wall venturi scrubber as claimed in claim 1, wherein said venturi tube is formed of an outer component and an inner component; said converging section is formed in said outer component; said throat and said diverging section are formed in said inner component; said outer component comprises a through hole for the insertion of one end of said inner component.

8. The wetted wall venturi scrubber as claimed in claim 7, wherein said venturi tube further comprises a throat jacket sleeved onto said inner component and disposed inside said outer component, said throat jacket and said inner component defining therebetween a scrubbing fluid inlet passage.

9. The wetted wall venturi scrubber as claimed in claim 8, wherein said inner component of said venturi tube comprises a plurality of small holes on the wall of the throat and connected to said scrubbing fluid inlet passage.

10. The wetted wall venturi scrubber as claimed in claim 8, wherein said inner component of said venturi tube comprises a rib extending around the periphery thereof and welded to a bottom side of said throat jacket.

11. The wetted wall venturi scrubber as claimed in claim 7, wherein said conduit is connected with said outer component by a connecting member.

12. The wetted wall venturi scrubber as claimed in claim 11, wherein said inner component is mounted inside said connecting member by a flange.

13. The wetted wall venturi scrubber as claimed in claim 1, wherein said venturi tube comprises a wall-wetting fluid supply pipe connected with a top side of said converging section, said wall-wetting fluid supply pipe extending along said converging section in the tangential direction.

\* \* \* \* \*