



US008362689B2

(12) **United States Patent**
Chen et al.

(10) **Patent No.:** **US 8,362,689 B2**
(45) **Date of Patent:** **Jan. 29, 2013**

(54) **PHOSPHORS AND LIGHT-EMITTING DEVICES USING THE SAME**

(75) Inventors: **Teng-Ming Chen**, Hsinchu (TW);
Te-Wen Kuo, Hsinchu (TW)

(73) Assignee: **National Chiao Tung University**,
Hsinchu (TW)

(*) Notice: Subject to any disclaimer, the term of this patent is extended or adjusted under 35 U.S.C. 154(b) by 13 days.

(21) Appl. No.: **13/021,393**

(22) Filed: **Feb. 4, 2011**

(65) **Prior Publication Data**

US 2012/0146486 A1 Jun. 14, 2012

(30) **Foreign Application Priority Data**

Dec. 8, 2010 (TW) 99142766 A

(51) **Int. Cl.**

H01J 1/62 (2006.01)

H01J 63/04 (2006.01)

(52) **U.S. Cl.** **313/503**; 313/498; 313/512; 313/486;
252/301.4 R; 252/301.4 S; 252/301.4 F

(58) **Field of Classification Search** 313/498-512,
313/483, 485, 486, 467; 252/301.4 R, 301.4 S,
252/301.4 F

See application file for complete search history.

(56) **References Cited**

U.S. PATENT DOCUMENTS

2004/0007961 A1* 1/2004 Srivastava et al. 313/486
2009/0085458 A1* 4/2009 Murazaki et al. 313/487

2009/0096361 A1* 4/2009 Fukuda et al. 313/504
2009/0295272 A1* 12/2009 Oshio 313/503
2011/0235309 A1* 9/2011 Miki et al. 362/97.2

FOREIGN PATENT DOCUMENTS

CN 100564478 12/2007
EP 2100943 A1 9/2009
WO WO 2009/109382 A1 9/2009

OTHER PUBLICATIONS

Brenchley, Matthew E. et al., "Synthesis and Structure of Sulfide Aluminate Sodalites", J. Mater Chem.; Jun. 10, 1992, pp. 1003-1005; 2(10).

Zhang, Xinmin et al., "Luminescent properties of Eu²⁺-activated SrLaGa₃S₆O phosphor" Journal of Alloys and Compounds; Jun. 18, 2004; pp. 247-251.

Jung, Sang Hyun et al., "Synthesis and Phase Transformation of Ca₁₀(PO₄)₆S Sulfoapatite by Solid-state Reaction with Sulfur Vapor", Synthesis and Reactivity in Inorganic, Metal-Organic, and Nano-Metal Chemistry; 2008; pp. 303-306.

Kuo, Te-Wen et al.; "Novel yellowish-orange Sr₈Al₁₂O₂₄S₂:Eu²⁺ phosphor for application in blue light-emitting diode based white LED"; Optical Society of America; Jun. 21, 2010, vol. 18, No. 102.

* cited by examiner

Primary Examiner — Anh T. Mai

Assistant Examiner — Kevin Quarterman

(74) *Attorney, Agent, or Firm* — Muncy, Geissler, Olds & Lowe, PLLC

(57) **ABSTRACT**

The present invention relates to novel phosphors, which are represented by a formula of (A_{1-x}M_x)₈D₁₂O₂₄S₂, wherein x, A, M and D are defined the same as the specification. In addition, the present invention further provides a light-emitting device using the above novel phosphors.

17 Claims, 6 Drawing Sheets

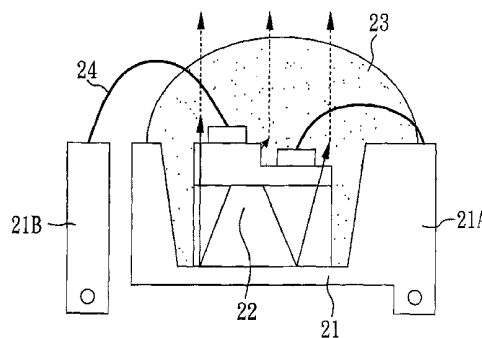
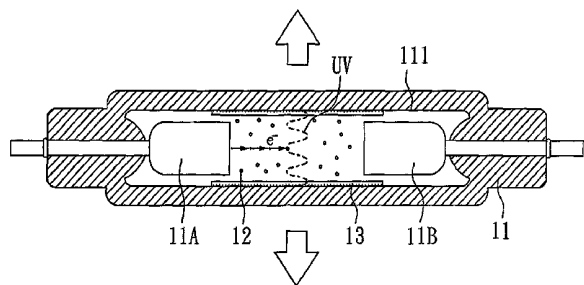

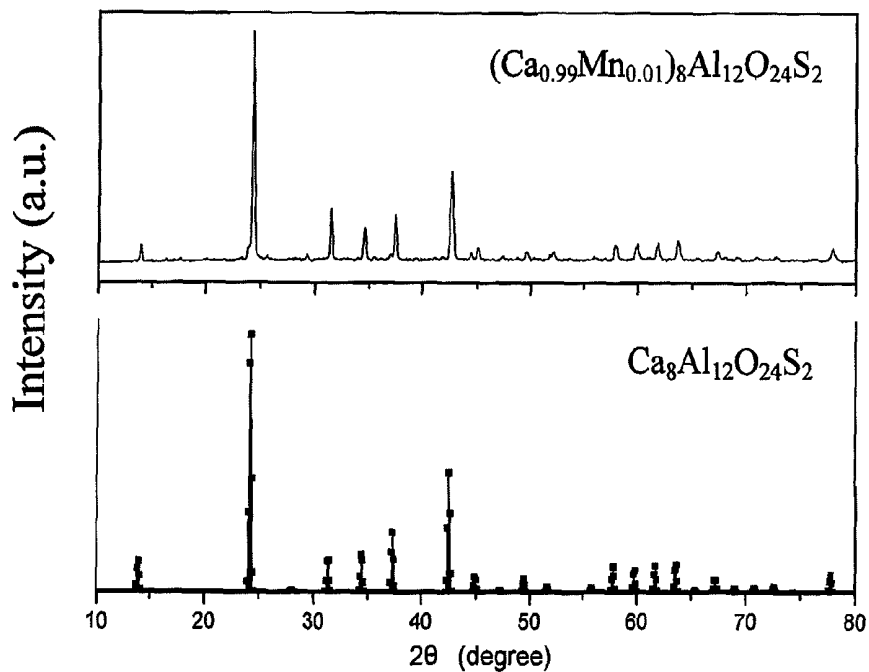

FIG. 1

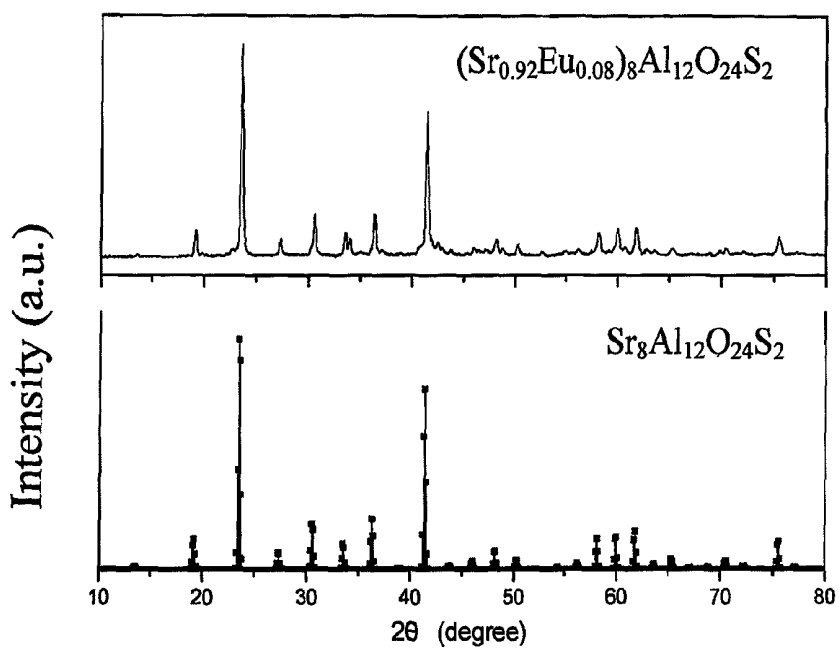

FIG. 2

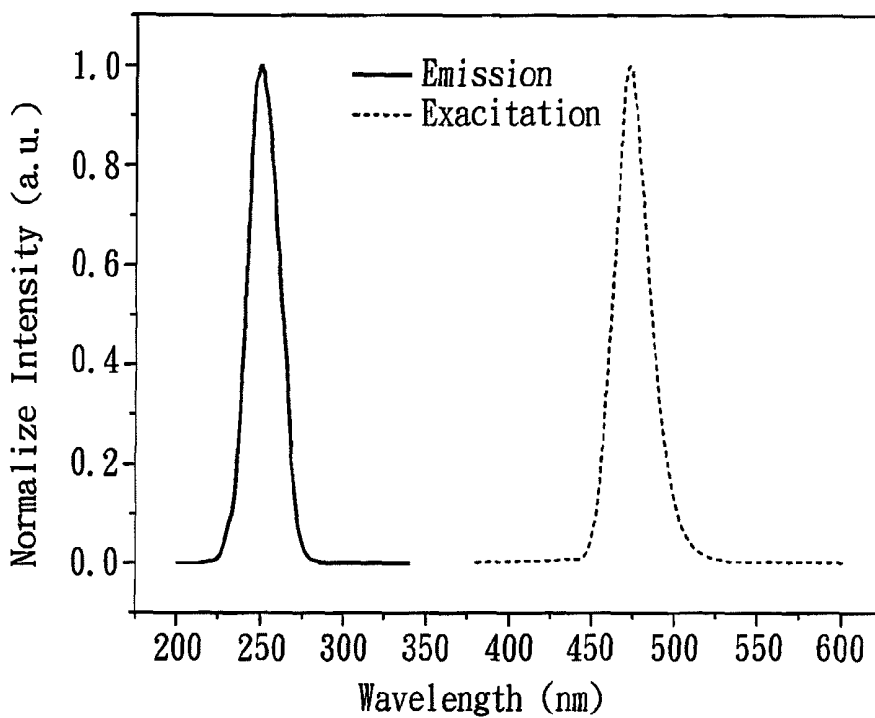

FIG. 3

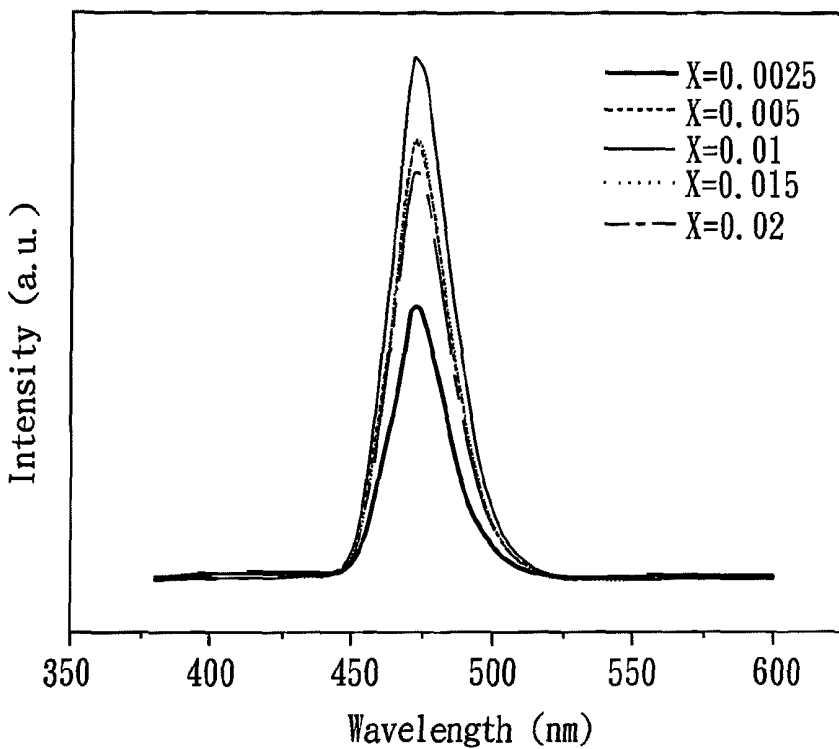

FIG. 4

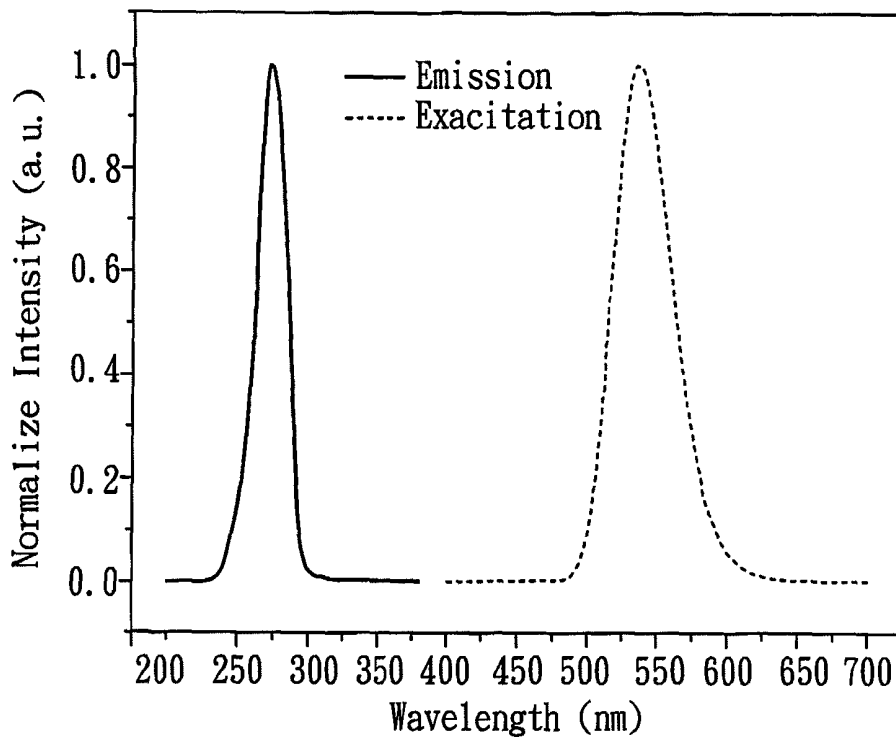

FIG. 5

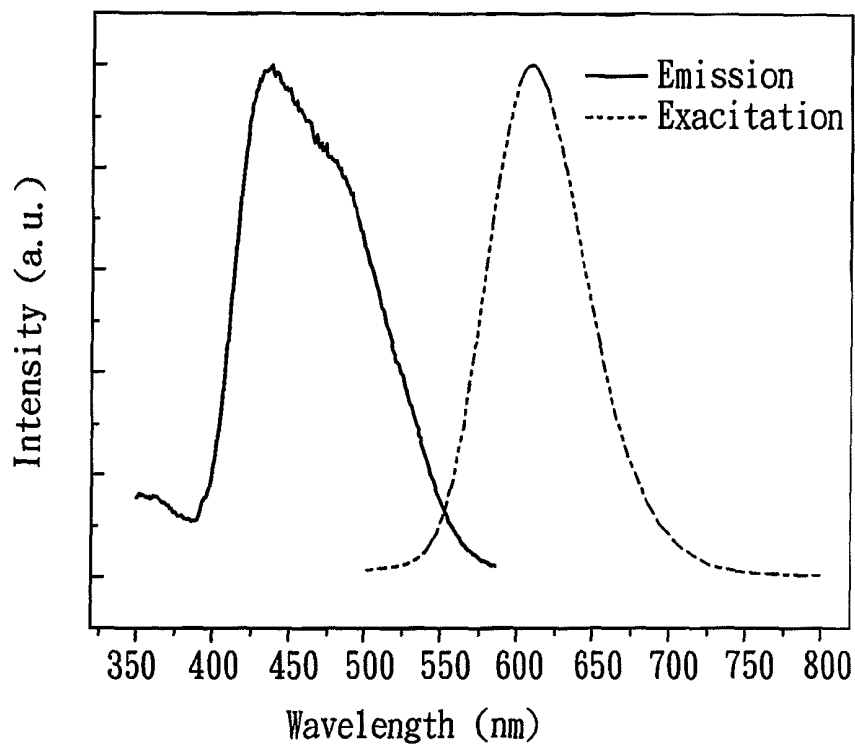

FIG. 6

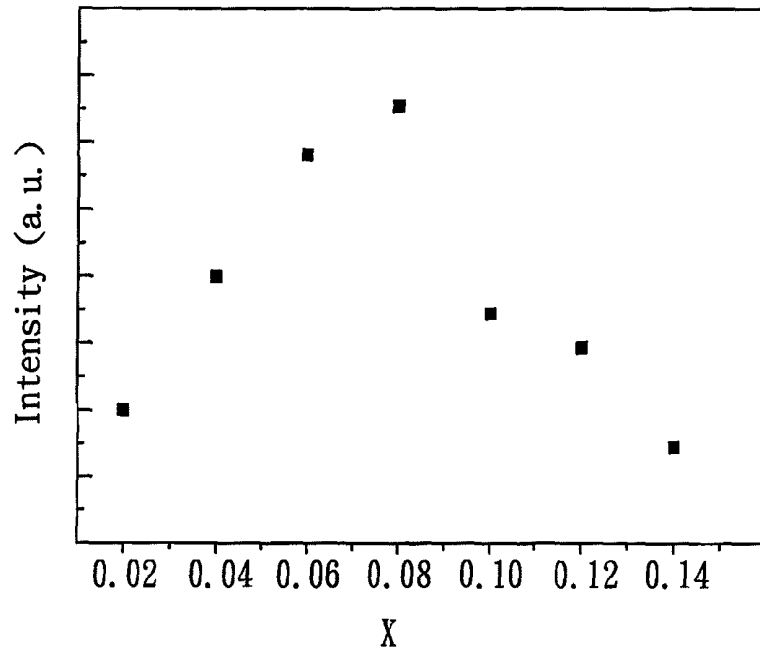

FIG. 7

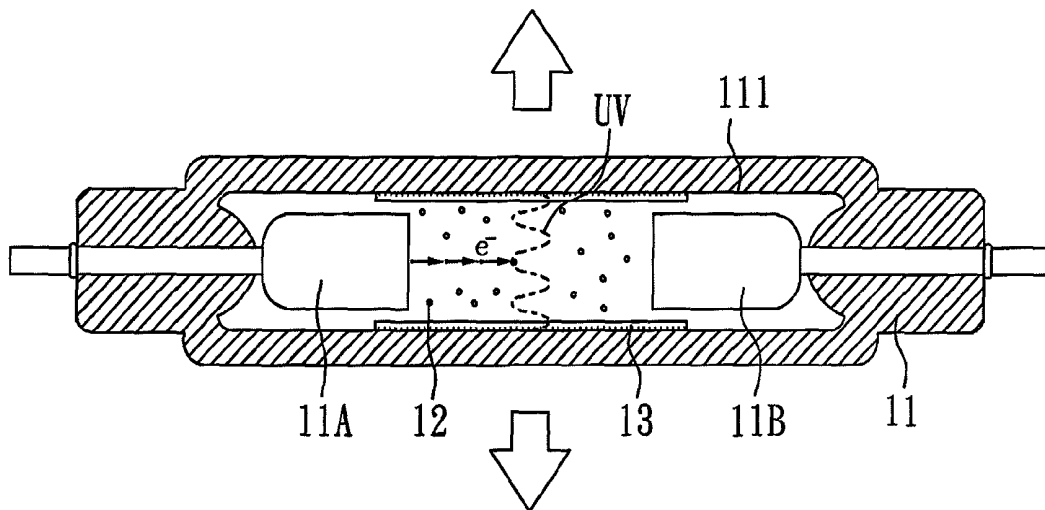

FIG. 8

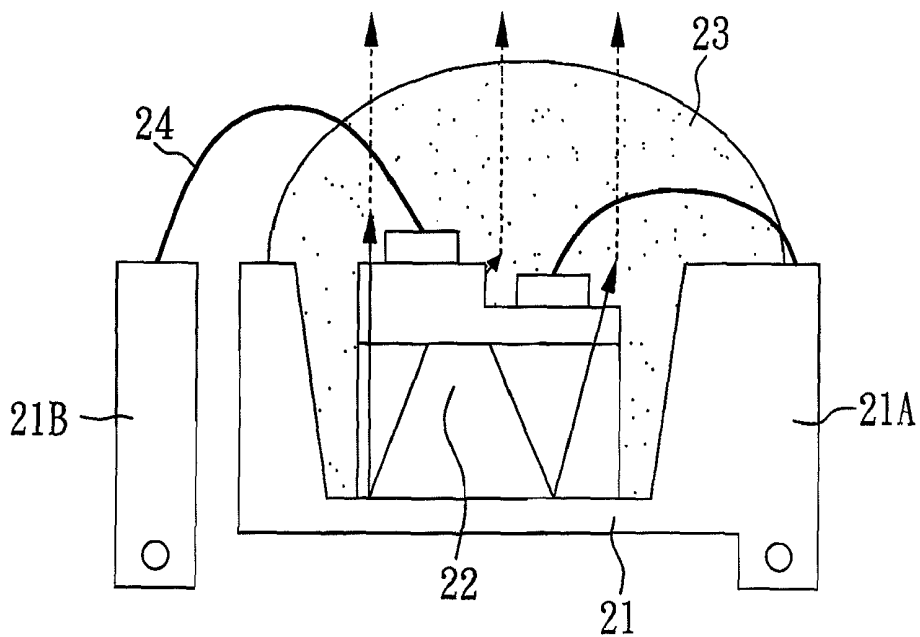

FIG. 9

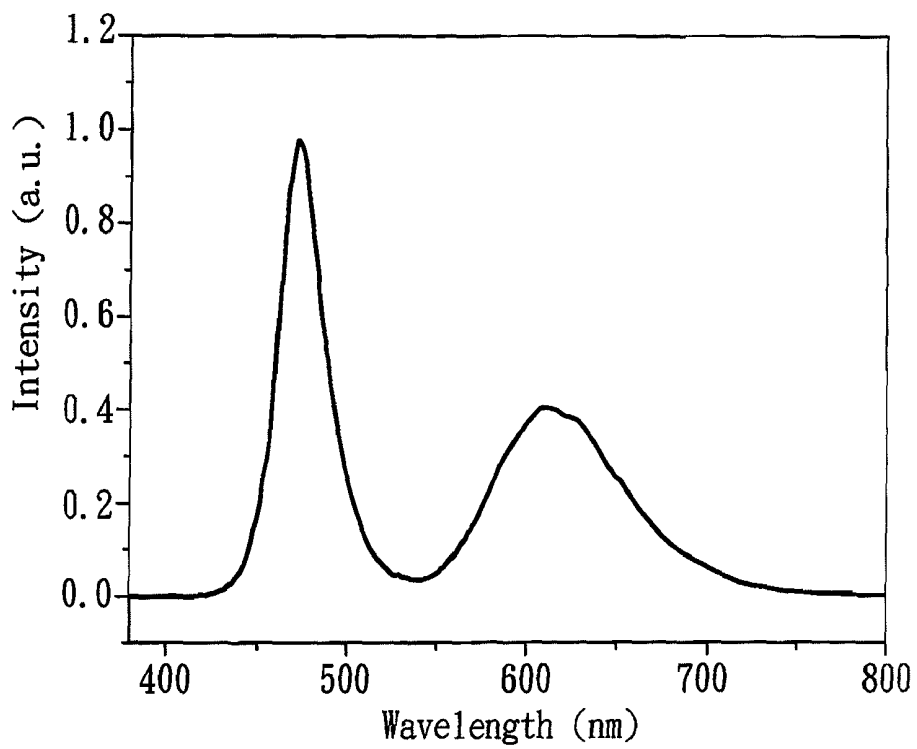

FIG. 10

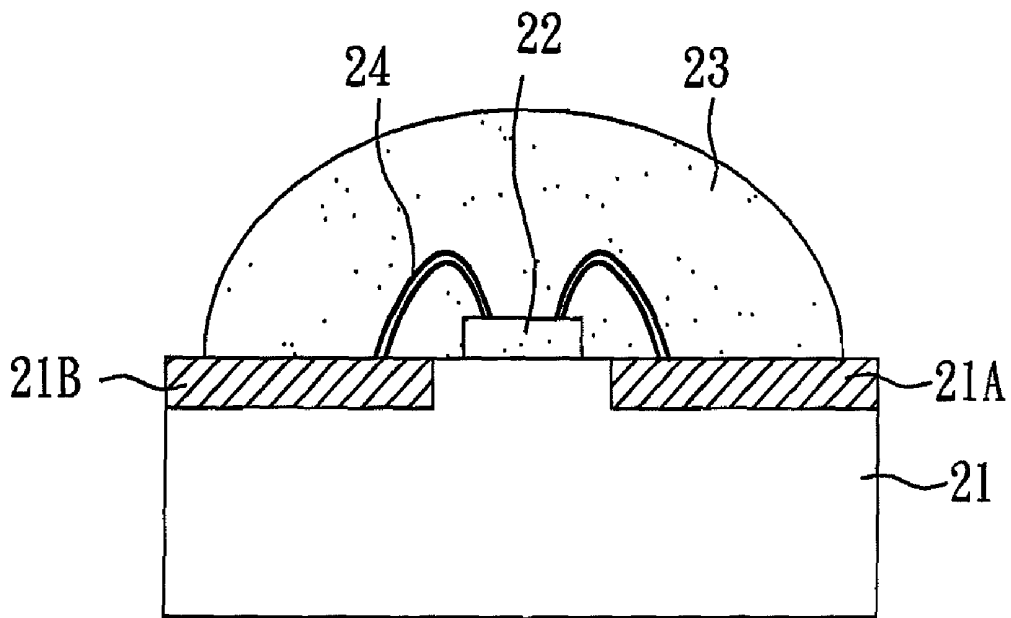

FIG. 11

PHOSPHORS AND LIGHT-EMITTING DEVICES USING THE SAME

CROSS REFERENCE TO RELATED APPLICATION

This application claims the benefits of the Taiwan Patent Application Serial Number 099142766, filed on Dec. 8, 2010, the subject matter of which is incorporated herein by reference.

BACKGROUND OF THE INVENTION

1. Field of the Invention

The present invention relates to novel phosphors and light-emitting devices using the same and, more particularly, to novel phosphors capable of being excited by blue light or UV light and light-emitting devices using the same.

2. Description of Related Art

Phosphors have been applied in lighting devices and display devices for a half century. Taking the most widely used fluorescent lamps for example, phosphors applied therein can be excited by mercury radiation as excitation light and then emit visible light. The light color emitted from a fluorescent lamp can be modified by mixing various phosphors and wide range of color temperature and color rendering characteristics for light output can be achieved, resulting in its wide application. However, most of commonly used three-basal-color phosphors have disadvantages of high cost due to that these phosphors often use limited reserves of rare elements (such as Eu, Ce, Tb etc.) as raw materials.

Recently, white light-emitting diodes (W-LEDs) also have been actively developed due to their high luminescence efficiency, low power consumption, long lifetime and environment friendly features in comparison with traditional lighting devices and thus are considered most potential to replace fluorescent lamps. For white light-emitting diodes, the methods of making white light include: as a first type, mixing light from red, green and blue LED chips in a white light-emitting module; as a second type, mixing light from a blue LED chip and yellow YAG phosphors that can be excited by the blue LED chip; and as a third type, mixing light from red, green and blue phosphors that are mixed with an optically transparent resin and can be excited by an UV LED.

Most of commercially available white LEDs apply the above-mentioned second method to emit white light. However, the second technology was claimed for a patent by Nichia. Accordingly, it is necessary to develop novel materials to overcome patent barrier.

SUMMARY OF THE INVENTION

The object of the present invention is to provide novel phosphors. Regarding the novel phosphors of the present invention, non-rare elements may be used as an active center to resolve the high cost issue resulting from conventional mercury radiation-excitatable phosphors using rare elements, or rare elements may be used as an active center to allow the phosphors to be applied in a mercury-free light-emitting device (such as LEDs).

To achieve the object, the present invention provides a phosphor represented by a chemical formula of $(A_{1-x}M_x)_8Al_{12}O_{24}S_2$, in which $0 < x < 1$; A is selected from the group consisting of Mg, Ca, Sr, Ba, Zn and a combination thereof; M is selected from the group consisting of Mn, Cu, Ag, Pb, Sb, Sn, Bi, Eu, Ce, Tb, Sm, Pr, Y, La, Gd, Lu, Sc, Nd,

Pm, Dy, Ho, Er, Tm, Yb and a combination thereof; and D is selected from the group consisting of B, Al, Ga, In and a combination thereof.

According to one aspect of the present invention, A may be Ca, Sr or a combination thereof, M may be Mn, and preferably $0 < x < 0.05$, more preferably $0.0025 \leq x \leq 0.02$. In this aspect, the phosphors use a transition metal element as an active center and can be excited by UV light. Hence, the phosphors according to this aspect can be fabricated in low cost in comparison with conventional mercury radiation-excitatable phosphors that use rare elements. Specifically, $(Ca_{1-x}Mn_x)_8Al_{12}O_{24}S_2$ and $(Sr_{1-x}Mn_x)_8Al_{12}O_{24}S_2$ can be used as a blue phosphor material and a green phosphor material, respectively, and can be excited by UV light that ranges from about 250 nm to 300 nm in wavelength. Thereby, the phosphors according to this aspect can be applied in light-emitting devices with UV excitation.

In another aspect of the present invention, A may be Sr, M may be Eu, and preferably $0 < x < 0.3$, more preferably $0.02 \leq x \leq 0.14$. The phosphors according to this aspect uses rare elements as an active center and can be excited by blue light that ranges from about 420 nm to 490 nm in wavelength. Thereby, the phosphors according to this aspect may be applied in mercury free light-emitting devices. In particular, the light emitted by the phosphors according to this aspect can be mixed with blue light to form white light, and thus the phosphors according to this aspect have the potential to replace YAG phosphors provided by Nichia.

The present invention further applies the above-mentioned phosphors in light-emitting devices. Accordingly, the present invention further provides a light-emitting device, including: an excitation unit for providing excitation light; and a phosphor layer capable of emitting visible light upon being excited by the excitation light, therewith the phosphor layer including phosphor(s) represented by a chemical formula of $(A_{1-x}M_x)_8D_{12}O_{24}S_2$, in which $0 < x < 1$; A is selected from the group consisting of Mg, Ca, Sr, Ba, Zn and a combination thereof; M is selected from the group consisting of Mn, Cu, Ag, Pb, Sb, Sn, Bi, Eu, Ce, Tb, Sm, Pr, Y, La, Gd, Lu, Sc, Nd, Pm, Dy, Ho, Er, Tm, Yb and a combination thereof; and D is selected from the group consisting of B, Al, Ga, In and a combination thereof.

In one aspect according to the present invention, an UV excitation unit, which can emit light of about 250 nm to 300 nm in wavelength, is used as the excitation unit. Additionally, according to the aspect, A may be Ca, Sr or a combination thereof, M may be Mn, and preferably $0 < x < 0.05$, more preferably $0.0025 \leq x \leq 0.02$. More specifically, the light-emitting device according to the aspect may use $(Ca_{1-x}Mn_x)_8Al_{12}O_{24}S_2$ and $(Sr_{1-x}Mn_x)_8Al_{12}O_{24}S_2$ as a blue phosphor material and a green phosphor material, respectively. Herein, the UV excitation unit may be any conventional devices capable of emitting UV light. For example, the UV excitation unit may include: a housing body provided with a cathode electrode and an anode electrode, therewith the phosphor layer being disposed on an inner wall of the housing body; and a discharge medium contained in the housing body for emitting the excitation light.

In the present invention, the housing body may be a transparent sealed tube and the discharge medium may include mercury and inert gas.

In another aspect according to the present invention, a blue excitation unit, which can emit light of about 420 nm to 490 nm in wavelength, is used as the excitation unit. Additionally, according to the aspect, A may be Sr, M may be Eu, and preferably $0 < x < 0.3$, more preferably $0.02 \leq x \leq 0.14$. Herein, the blue excitation unit may be any conventional devices

capable of emitting blue light. For example, the blue excitation unit may include: a carrier provided with a cathode electrode and an anode electrode; a blue light-emitting component disposed on the carrier and electrically connected with the cathode electrode and the anode electrode, therewith the phosphor layer covering the blue light-emitting component.

In the present invention, the carrier is not particularly limited and may be a circuit substrate or a packaging base with lead frames. In addition, the blue light-emitting component is not particularly limited and may be a blue LED chip.

Accordingly, the novel phosphors provided by the present invention may use non-rare elements as an active center to resolve the high cost issue resulting from conventional mercury radiation-excitabile phosphors using rare elements, or uses rare elements as an active center to allow the phosphors to be applied in a mercury-free light-emitting device (such as LEDs) and replace YAG phosphors provided by Nichia.

BRIEF DESCRIPTION OF THE DRAWINGS

FIG. 1 shows XRD spectra of the $(Ca_{0.99}Mn_{0.01})_8Al_{12}O_{24}S_2$ phosphor prepared by the preparation example 3 according to the present invention and $Ca_8Al_{12}O_{24}S_2$;

FIG. 2 shows XRD spectra of the $(Sr_{0.92}Eu_{0.08})_8Al_{12}O_{24}S_2$ phosphor prepared by the preparation example 9 according to the present invention and $Sr_8Al_{12}O_{24}S_2$;

FIG. 3 shows the photoluminescence (PL) and photoluminescence excitation (PLE) spectra of $(Ca_{0.99}Mn_{0.01})_8Al_{12}O_{24}S_2$ phosphor prepared by the preparation example 3 according to the present invention;

FIG. 4 shows an emission intensity as a function of Mn concentration (x) for $(Ca_{1-x}Mn_x)_8Al_{12}O_{24}S_2$ phosphors prepared by the preparation examples 1-5 according to the present invention;

FIG. 5 shows the photoluminescence (PL) and photoluminescence excitation (PLE) spectra of $(Sr_{0.99}Mn_{0.01})_8Al_{12}O_{24}S_2$ prepared by the preparation example 15 according to the present invention;

FIG. 6 shows the photoluminescence (PL) and photoluminescence excitation (PLE) spectra of $(Sr_{0.92}Eu_{0.08})_8Al_{12}O_{24}S_2$ phosphor prepared by the preparation example 9 according to the present invention;

FIG. 7 shows an emission intensity as a function of Eu concentration (x) for $(Sr_{1-x}Eu_x)_8Al_{12}O_{24}S_2$ phosphors prepared by the preparation examples 6-12 according to the present invention;

FIG. 8 shows a cross-sectional view of a light-emitting device according to the example 1 of the present invention;

FIG. 9 shows a cross-sectional view of a light-emitting device according to the example 2 of the present invention;

FIG. 10 shows electroluminescence spectra of the light-emitting device according to the example 2 of the present invention; and

FIG. 11 shows a cross-sectional view of a light-emitting device according to the example 3 of the present invention.

DETAILED DESCRIPTION OF THE PREFERRED EMBODIMENT

Hereafter, examples will be provided to illustrate the embodiments of the present invention. Other advantages and effects of the invention will become more apparent from the disclosure of the present invention. It should be noted that these accompanying figures are simplified. The quantity, shape and size of components shown in the figures may be modified according to practically conditions, and the arrange-

ment of components may be more complex. Other various aspects also may be practiced or applied in the invention, and various modifications and variations can be made without departing from the spirit of the invention based on various concepts and applications.

PREPARATION EXAMPLES 1 to 5

According to Table 1, a stoichiometric mixture of $CaCO_3$, $CaSO_4$, Al_2O_3 and MnO was ground together for 10 minutes and then put into a crucible to perform a sintering process in a furnace at about 1100° C. to 1400° C. for about 4 to 8 hours so as to obtain a product of $(Ca_{1-x}Mn_x)_{64}[Al_{96}O_{192}](SO_4)_{16}$. The as-obtained product was ground for 5 minutes and then heated under N_2 atmosphere at about 800° C. to 1000° C. for about 4 to 8 hours so as to obtain the phosphor material of $(Ca_{1-x}Mn_x)_8Al_{12}O_{24}S_2$. The reaction equation is shown as follows:

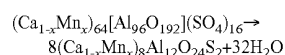

TABLE 1

	x	CaCO ₃ :CaSO ₄ :Al ₂ O ₃ :MnO (molar ratio)			
		CaCO ₃ (g)	CaSO ₄ (g)	Al ₂ O ₃ (g)	MnO (g)
Preparation Example 1	0.0025		47.84:16:48:0.16		
Preparation Example 2	0.005	0.4784	0.2176	0.4896	0.001125
Preparation Example 3	0.01	0.4768	0.2176	0.4896	0.00225
Preparation Example 4	0.015	0.4736	0.2176	0.4896	0.0045
Preparation Example 5	0.02	0.4704	0.2176	0.4896	0.00675
		0.4672	0.2176	0.4896	0.009

The phosphors prepared from Preparation Examples 1 to 5 were verified by powder X-ray diffraction analysis with an automatic diffractometer (Broker AXS D8 Advance) with a Cu target, in which the Cu target was bombarded by an electron beam and then emitted characteristic X-ray. FIG. 1 shows the XRD patterns of the $(Ca_{1-x}Mn_x)_8Al_{12}O_{24}S_2$ phosphor, in which the upper diagram shows signal patterns of $(Ca_{0.99}Mn_{0.01})_8Al_{12}O_{24}S_2$ and the lower diagram shows signal patterns of $Ca_8Al_{12}O_{24}S_2$. The XRD spectra of phosphors with various doping concentrations (x=0.0025, 0.005, 0.015, 0.02) are the same as the upper diagram in FIG. 1.

PREPARATION EXAMPLES 6 to 12

According to Table 2, a stoichiometric mixture of $SrCO_3$, $SrSO_4$, Al_2O_3 and Eu_2O_3 was ground together for 10 minutes and then put into a crucible to perform a sintering process in a furnace at about 1100° C. to 1400° C. for about 4 to 8 hours so as to obtain a product of $(Sr_{1-x}Eu_x)_{64}[Al_{96}O_{192}](SO_4)_{16}$. The as-obtained product was ground for 5 minutes and then heated under N_2 atmosphere at about 800° C. to 1000° C. for about 4 to 8 hours so as to obtain the phosphor material of $(Sr_{1-x}Eu_x)_8Al_{12}O_{24}S_2$. The reaction equation is shown as follows:

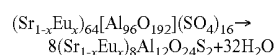

TABLE 2

	x	SrCO ₃ :SrSO ₄ :Al ₂ O ₃ :Eu ₂ O ₃ (molar ratio)			
		SrCO ₃ (g)	SrSO ₄ (g)	Al ₂ O ₃ (g)	Eu ₂ O ₃ (g)
Preparation Example 6	0.02	0.3448	46.72:16:48:0.64	0.2448	0.01125
Preparation Example 7	0.04	0.3354	45.44:16:48:1.28	0.2448	0.0225
Preparation Example 8	0.06	0.3259	44.16:16:48:1.92	0.2448	0.03375
Preparation Example 9	0.08	0.3165	42.88:16:48:2.56	0.2448	0.0450
Preparation Example 10	0.10	0.3071	41.6:16:48:3.2	0.2448	0.05625
Preparation Example 11	0.12	0.2976	40.32:16:48:3.84	0.2448	0.0675
Preparation Example 12	0.14	0.2882	39.04:16:48:4.48	0.2448	0.07875

The phosphors prepared from Preparation Examples 11 to 12 were verified by powder X-ray diffraction analysis with an automatic diffractometer (Broker AXS D8 Advance) with a Cu target, in which the Cu target was bombarded by an electron beam and then emitted characteristic X-ray. FIG. 2 shows the XRD patterns of the (Sr_{1-x}Eu_x)₈Al₁₂O₂₄S₂ phosphor, in which the upper diagram shows signal patterns of (Sr_{0.98}Eu_{0.02})₈Al₁₂O₂₄S₂ and the lower diagram shows signal patterns of Sr₈Al₁₂O₂₄S₂. The XRD spectra of phosphors with various doping concentrations (x=0.02, 0.04, 0.06, 0.10, 0.12, 0.14) are the same as the upper diagram in FIG. 2.

PREPARATION EXAMPLES 13 to 17

According to Table 3, a stoichiometric mixture of SrCO₃, SrSO₄, Al₂O₃ and MnO was ground together for 10 minutes and then put into a crucible to perform a sintering process in a furnace at about 1100° C. to 1400° C. for about 4 to 8 hours so as to obtain a product of (Sr_{1-x}Mn_x)₆₄[Al₉₆O₁₉₂](SO₄)₁₆. The as-obtained product was ground for 5 minutes and then heated under N₂ atmosphere at about 800° C. to 1000° C. for about 4 to 8 hours so as to obtain the phosphor material of (Sr_{1-x}Mn_x)₈Al₁₂O₂₄S₂. The reaction equation is shown as follows:

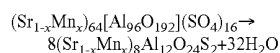

TABLE 3

	x	SrCO ₃ :SrSO ₄ :Al ₂ O ₃ :MnO (molar ratio)			
		SrCO ₃ (g)	SrSO ₄ (g)	Al ₂ O ₃ (g)	MnO (g)
Preparation Example 13	0.0025	0.3531	47.84:16:48:0.16	0.2448	0.000575
Preparation Example 14	0.005	0.3520	47.68:16:48:0.32	0.2448	0.00115
Preparation Example 15	0.01	0.3496	47.36:16:48:0.64	0.2448	0.0023
Preparation Example 16	0.015	0.3472	47.04:16:48:0.96	0.2448	0.00345
Preparation Example 17	0.02	0.3449	46.72:16:48:1.28	0.2448	0.0046

The phosphors prepared from Preparation Examples 13 to 17 were verified by powder X-ray diffraction analysis with an automatic diffractometer (Bruker AXS D8 Advance) with a Cu target, in which the Cu target was bombarded by an electron beam and then emitted characteristic X-ray. The XRD spectra of (Sr_{1-x}Mn_x)₈Al₁₂O₂₄S₂ phosphors are the same as FIG. 2.

TEST EXAMPLE 1

The emission measurements of (Ca_{1-x}Mn_x)₈Al₁₂O₂₄S₂ phosphors were performed by using a Spex Fluorolog-3 spectrofluorometer (Instruments S.A., Edison, N.J., USA) equipped with a 450 W Xe light source and double excitation monochromators. In addition, a DT-100 Color Analyzer was used for the measurement of CIE chromaticity coordinates (x, y).

FIG. 3 shows the photoluminescence (PL) and photoluminescence excitation (PLE) spectra of (Ca_{0.99}Mn_{0.01})₈Al₁₂O₂₄S₂ phosphor. It shows that the excitation wavelength is about 254 nm and the emission wavelength is about 476 nm for (Ca_{1-x}Mn_x)₈Al₁₂O₂₄S₂ phosphor. FIG. 4 shows an emission intensity as a function of Mn concentration (x) for (Ca_{1-x}Mn_x)₈Al₁₂O₂₄S₂ phosphors. Additionally, the cm chromaticity coordinate of (Ca_{0.99}Mn_{0.01})₈Al₁₂O₂₄S₂ phosphor is (0.12, 0.11).

TEST EXAMPLE 2

The emission measurements of (Sr_{1-x}Mn_x)₈Al₁₂O₂₄S₂ phosphors were performed by using a Spex Fluorolog-3 spectrofluorometer (Instruments S.A., Edison, N.J., USA) equipped with a 450 W Xe light source and double excitation monochromators. In addition, a DT-100 Color Analyzer was used for the measurement of CIE chromaticity coordinates (x, y).

FIG. 5 shows the photoluminescence (PL) and photoluminescence excitation (PLE) spectra of (Sr_{0.99}Mn_{0.01})₈Al₁₂O₂₄S₂ phosphor. It shows that the excitation wavelength is about 254 nm and the emission wavelength is about 538 nm for (Sr_{1-x}Mn_x)₈Al₁₂O₂₄S₂ phosphor. Additionally, the CIE chromaticity coordinate of (Sr_{0.99}Mn_{0.01})₈Al₁₂O₂₄S₂ phosphor is (0.33, 0.67).

TEST EXAMPLE 3

The emission measurements of (Sr_{1-x}Eu_x)₈Al₁₂O₂₄S₂ phosphors were performed by using a Spex Fluorolog-3 spectrofluorometer (USA) equipped with a 450 W Xe light source and double excitation monochromators and Hamamatsu Photonics R928 type photomultiplier as a detector. In addition, a DT-100 Color Analyzer was used for the measurement of CIE chromaticity coordinates (x, y).

FIG. 6 shows the photoluminescence (PL) and photoluminescence excitation (PLE) spectra of (Sr_{0.92}Eu_{0.08})₈Al₁₂O₂₄S₂ phosphor. It shows that the excitation wavelength is about 450 nm and the emission wavelength is about 605 nm for (Sr_{1-x}Eu_x)₈Al₁₂O₂₄S₂ phosphor. FIG. 7 shows an emission intensity as a function of Eu concentration (x) for (Sr_{1-x}Eu_x)₈Al₁₂O₂₄S₂ phosphors. Additionally, the CIE chromaticity coordinate of (Sr_{0.92}Eu_{0.08})₈Al₁₂O₂₄S₂ phosphor is (0.61, 0.38).

EXAMPLE 1

FIG. 8 shows a cross-sectional view of a light-emitting device according to one preferred example of the present invention.

As shown in FIG. 8, the light-emitting device according to the present example includes: a housing body 11 equipped with a cathode electrode 11A and an anode electrode 11B; a discharge medium 12 contained in the housing body 11; and a phosphor layer 13 disposed on an inner wall 111 of the housing body 11. In detail, the light-emitting device provided by the present example is a cold cathode fluorescent lamp,

which uses a transparent sealed tube as the housing body **11** to contain the discharge medium **12** therein and to dispose the cathode electrode **11A** and the anode electrode **11B** at its two terminals. In the light-emitting device according to the present example, mercury and rare gas are used as the discharge medium **12**, and the phosphors prepared by the preparation examples 3 and 15 are used in the phosphor layer **13** as a blue phosphor and a green phosphor, respectively. Accordingly, upon a high voltage is applied between the cathode electrode **11A** and the anode electrode **11B** at both terminals of the housing body **11**, electrons will be emitted and accelerated to hit mercury atoms filled in the housing body **11** and thus to excite mercury atoms, such that mercury atoms will emit UV light to excite phosphors in the phosphor layer **13**, resulting in the emission of visible light.

EXAMPLE 2

FIG. 9 shows a cross-sectional view of a light-emitting device according to another preferred example of the present invention.

As shown in FIG. 9, the light-emitting device according to the present example includes: a carrier **21**; a blue light-emitting component **22** disposed on the carrier **21** and electrically connected with the carrier **21**; and a phosphor layer **23** covering the blue light-emitting component **22**. In detail, the light-emitting device according to the present example is a white light-emitting diode, which uses a packaging base with lead frames as the carrier **21**. Herein, the carrier **21** is provided with a cathode electrode **21A** (i.e. a mount lead) and an anode electrode **21B** (i.e. an inner lead), and the blue light-emitting component **22** is electrically connected with the cathode electrode **21A** and the anode electrode **21B** of the carrier **21** via wires **24**. Additionally, in the present example, an InGaN-based LED chip capable of emitting light of about 470 nm is used as the blue light-emitting component **22**, and the phosphor layer **23** is made of a transparent molding material doped with the yellowish phosphor prepared by the preparation example 9. Accordingly, upon a high voltage is applied between the cathode electrode **21A** and the anode electrode **21B** of the carrier **21**, the blue light-emitting component **22** will be driven and emit blue light to excite the phosphor in the phosphor material layer **23**, and then the yellowish light emitted from the phosphor will be mixed with the blue light from the blue light-emitting component **22**, resulting in emission of white light.

The measured luminous efficiency of the white LED according to the present example reaches as high as about 14.2 lm/W under 400 mA driving current, as shown in FIG. 10. Additionally, the CIE chromaticity coordinate is (0.34, 0.25), and the correlated color temperature (CCT) is about 4300 K.

EXAMPLE 3

FIG. 11 shows a cross-sectional view of a light-emitting device according to yet another preferred example of the present invention.

As shown in FIG. 11, the light-emitting device according to the present example includes: a carrier **21**; a blue light-emitting component **22** disposed on the carrier **21** and electrically connected with the carrier **21**; and a phosphor layer **23** covering the blue light-emitting component **22**. In detail, the light-emitting device according to the present example is a white light-emitting diode, which uses a circuit substrate as the carrier **21**. Herein, the carrier **21** is provided with a cathode electrode **21A** and an anode electrode **21B**, and the blue

light-emitting component **22** is electrically connected to the cathode electrode **21A** and the anode electrode **21B** of the carrier **21** via wires **24**. Additionally, in the present example, an InGaN-based LED chip capable of emitting light of about 470 nm is used as the blue light-emitting component **22**, and the phosphor layer **23** is made of a transparent molding material doped with the yellowish phosphor prepared by the preparation example 9. Accordingly, as mentioned in the example 2, the yellowish light from the phosphor material layer **23** would be mixed with the blue light from the blue light-emitting component **22**, resulting in emission of white light.

The above examples are intended for illustrating the embodiments of the subject invention and the technical features thereof, but not for restricting the scope of protection of the subject invention. The scope of the subject invention is based on the claims as appended.

What is claimed is:

1. A phosphor represented by a chemical formula of $(A_{1-x}M_x)_8D_{12}O_{24}S_2$, wherein $0 < x < 1$;

A is selected from the group consisting of Mg, Ca, Sr, Ba, Zn and a combination thereof;

M is selected from the group consisting of Mn, Cu, Ag, Pb, Sb, Sn, Bi, Eu, Ce, Tb, Sm, Pr, Y, La, Gd, Lu, Sc, Nd, Pm, Dy, Ho, Er, Tm, Yb and a combination thereof; and

D is selected from the group consisting of B, Al, Ga, In and a combination thereof.

2. The phosphor as claimed in claim 1, wherein A is Ca, Sr or a combination thereof, M is Mn and $0 < x < 0.05$.

3. The phosphor as claimed in claim 2, wherein $0.0025 \leq x \leq 0.02$.

4. The phosphor as claimed in claim 1, wherein A is Sr, M is Eu and $0 < x < 0.3$.

5. The phosphor as claimed in claim 4, wherein $0.02 \leq x \leq 0.14$.

6. A light-emitting device, comprising:

an excitation unit for providing excitation light; and
a phosphor layer capable of emitting visible light upon being excited by the excitation light, therewith the phosphor layer comprising a phosphor represented by a chemical formula of $(A_{1-x}M_x)_8D_{12}O_{24}S_2$, wherein $0 < x < 1$;

A is selected from the group consisting of Mg, Ca, Sr, Ba, Zn and a combination thereof;

M is selected from the group consisting of Mn, Cu, Ag, Pb, Sb, Sn, Bi, Eu, Ce, Tb, Sm, Pr, Y, La, Gd, Lu, Sc, Nd, Pm, Dy, Ho, Er, Tm, Yb and a combination thereof; and

D is selected from the group consisting of B, Al, Ga, In and a combination thereof.

7. The light-emitting device as claimed in claim 6, wherein the excitation unit is an UV excitation unit.

8. The light-emitting device as claimed in claim 7, wherein A is Ca, Sr or a combination thereof, M is Mn and $0 < x < 0.05$.

9. The light-emitting device as claimed in claim 8, wherein $0.0025 \leq x \leq 0.02$.

10. The light-emitting device as claimed in claim 7, wherein the excitation light ranges from 250 nm to 300 nm in wavelength.

11. The light-emitting device as claimed in claim 7, wherein the UV excitation unit comprises: a housing body provided with a cathode electrode and an anode electrode, therewith the phosphor layer being disposed on an inner wall of the housing body; and a discharge medium contained in the housing body for emitting the excitation light.

9

12. The light-emitting device as claimed in claim 6, wherein the excitation unit is a blue excitation unit.

13. The light-emitting device as claimed in claim 12, wherein A is Sr, M is Eu and $0 < x < 0.3$.

14. The light-emitting device as claimed in claim 13, wherein $0.02 \leq x \leq 0.14$.

15. The light-emitting device as claimed in claim 12, wherein the excitation light ranges from 420 nm to 490 nm in wavelength.

16. The light-emitting device as claimed in claim 12, wherein the blue excitation unit comprises: a carrier provided

10

with a cathode electrode and an anode electrode; and a blue light-emitting component disposed on the carrier and electrically connected with the cathode electrode and the anode electrode, therewith the phosphor layer covering the blue light-emitting component.

17. The light-emitting device as claimed in claim 16, wherein the carrier is a circuit substrate or a packaging base with lead frames.

* * * * *