



US 20140179496A1

(19) **United States**

(12) **Patent Application Publication**
Yang et al.

(10) **Pub. No.: US 2014/0179496 A1**

(43) **Pub. Date: Jun. 26, 2014**

(54) **MUSCULATURE TRAINING DEVICE**

(52) **U.S. Cl.**

(71) Applicant: **NATIONAL CHIAO TUNG UNIVERSITY**, Hsinchu (TW)

CPC *A63B 21/045* (2013.01)

USPC **482/121**

(72) Inventors: **Bing-Shiang Yang**, Hsinchu (TW);
Yu-Tang Wen, Hsinchu (TW)

(57) **ABSTRACT**

(73) Assignee: **NATIONAL CHIAO TUNG UNIVERSITY**, Hsinchu (TW)

A musculature training device is disclosed. The musculature training device includes an attaching member, a fixing-and-adjusting member coupled to the attaching member, and an elastic member connected to the fixing-and-adjusting member, wherein the fixing-and-adjusting member sets an initial length of the elastic member. When a user move his/her body or limbs to deform the elastic member and change the initial length of the elastic member, the elastic member generates a restoring force that provides a resistance needed for a musculature training around the user's joint. Therefore, the user can train himself anytime and anywhere. Moreover, the user is allowed to perform a single joint musculature training to avoid sport injury and improve training effectiveness.

(21) Appl. No.: **13/852,209**

(22) Filed: **Mar. 28, 2013**

(30) **Foreign Application Priority Data**

Dec. 20, 2012 (TW) 101148621

Publication Classification

(51) **Int. Cl.**
A63B 21/045 (2006.01)

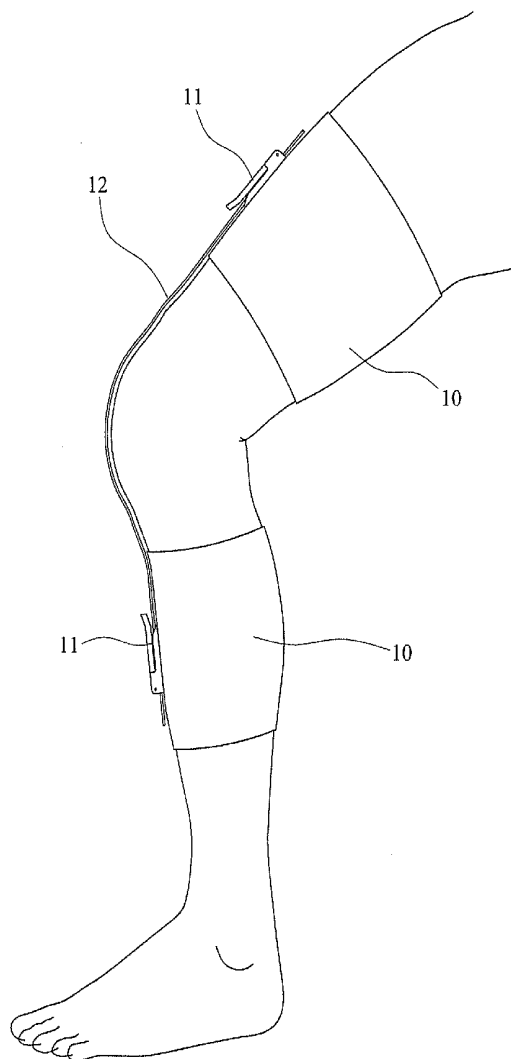

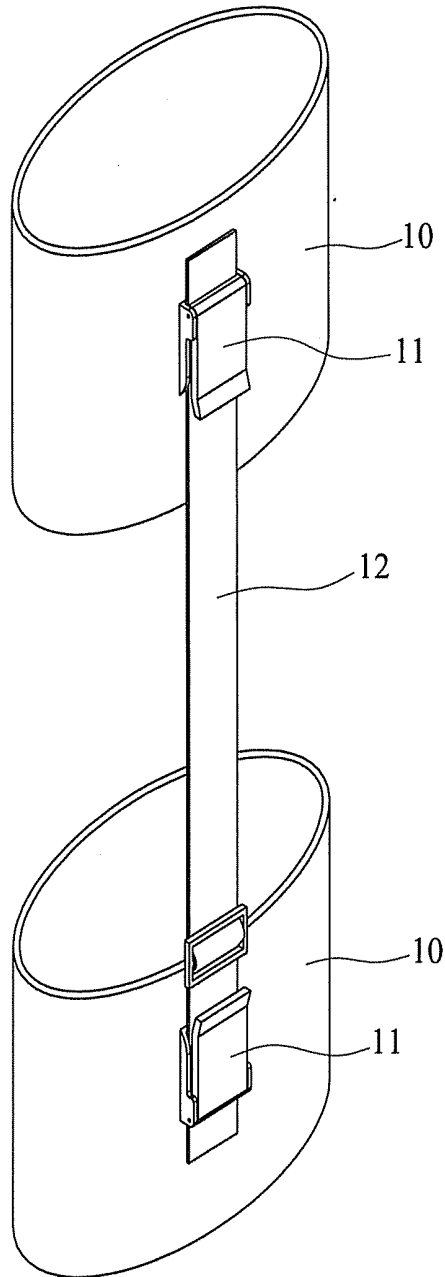

FIG. 1A

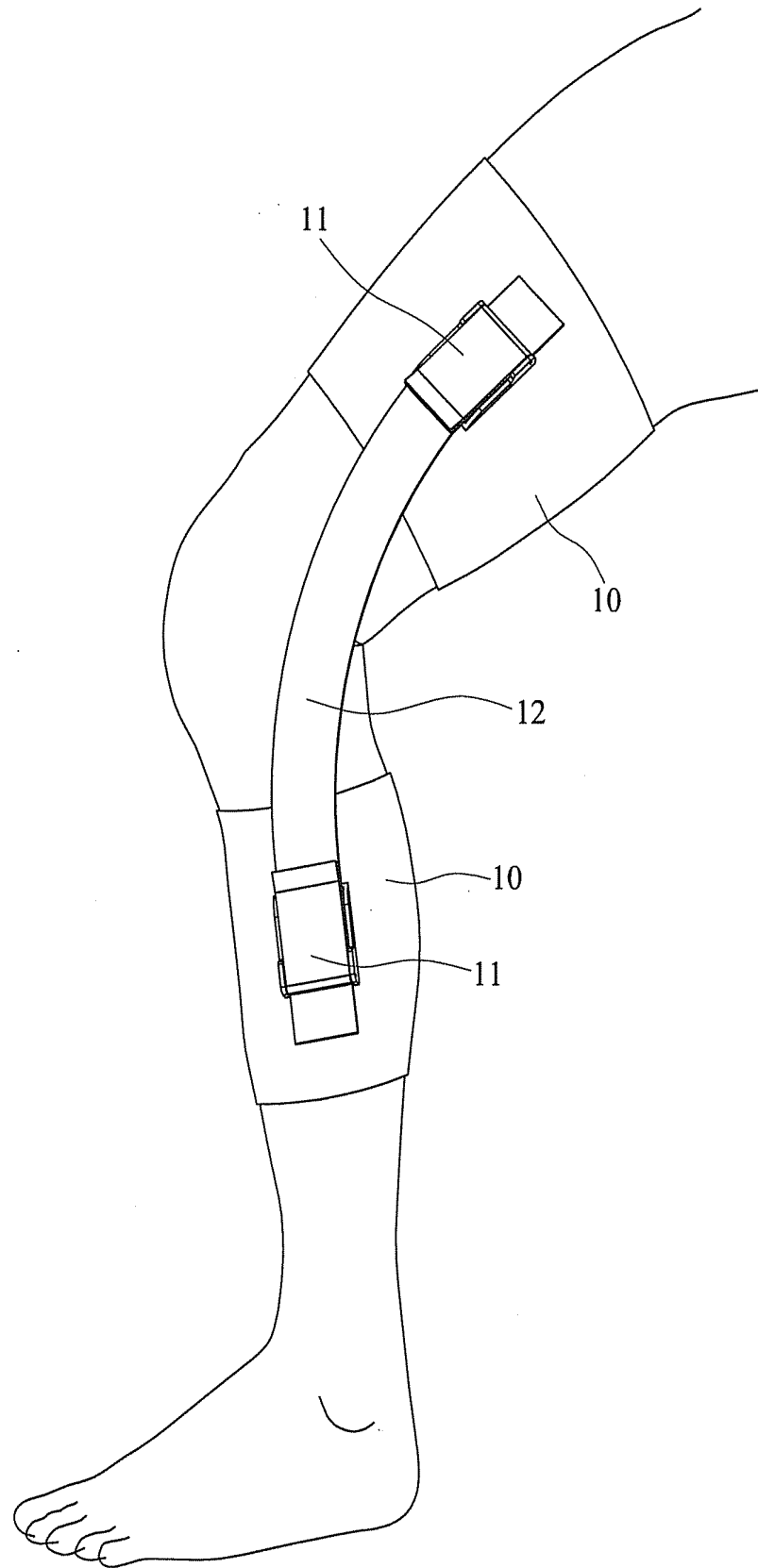

FIG. 1B

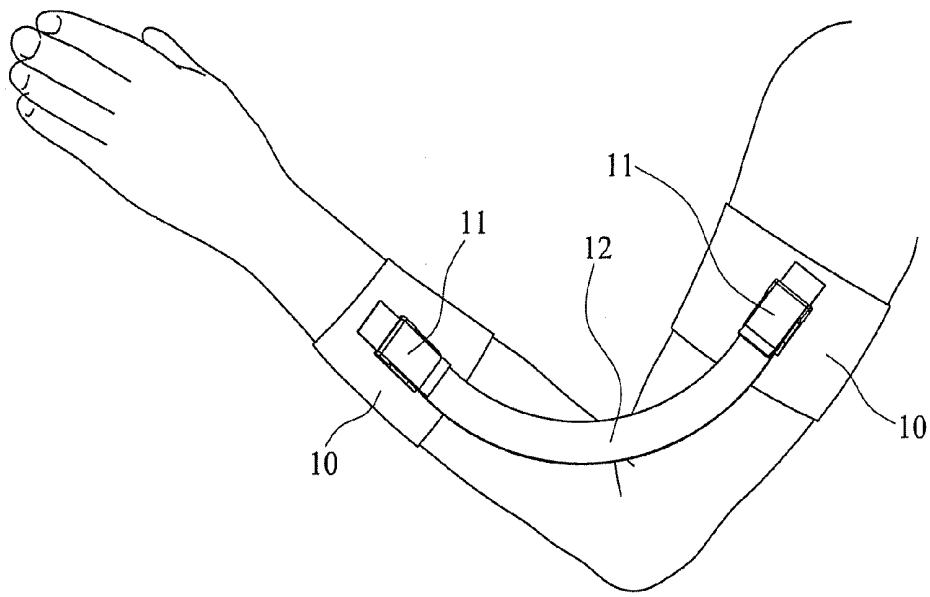

FIG. 1C

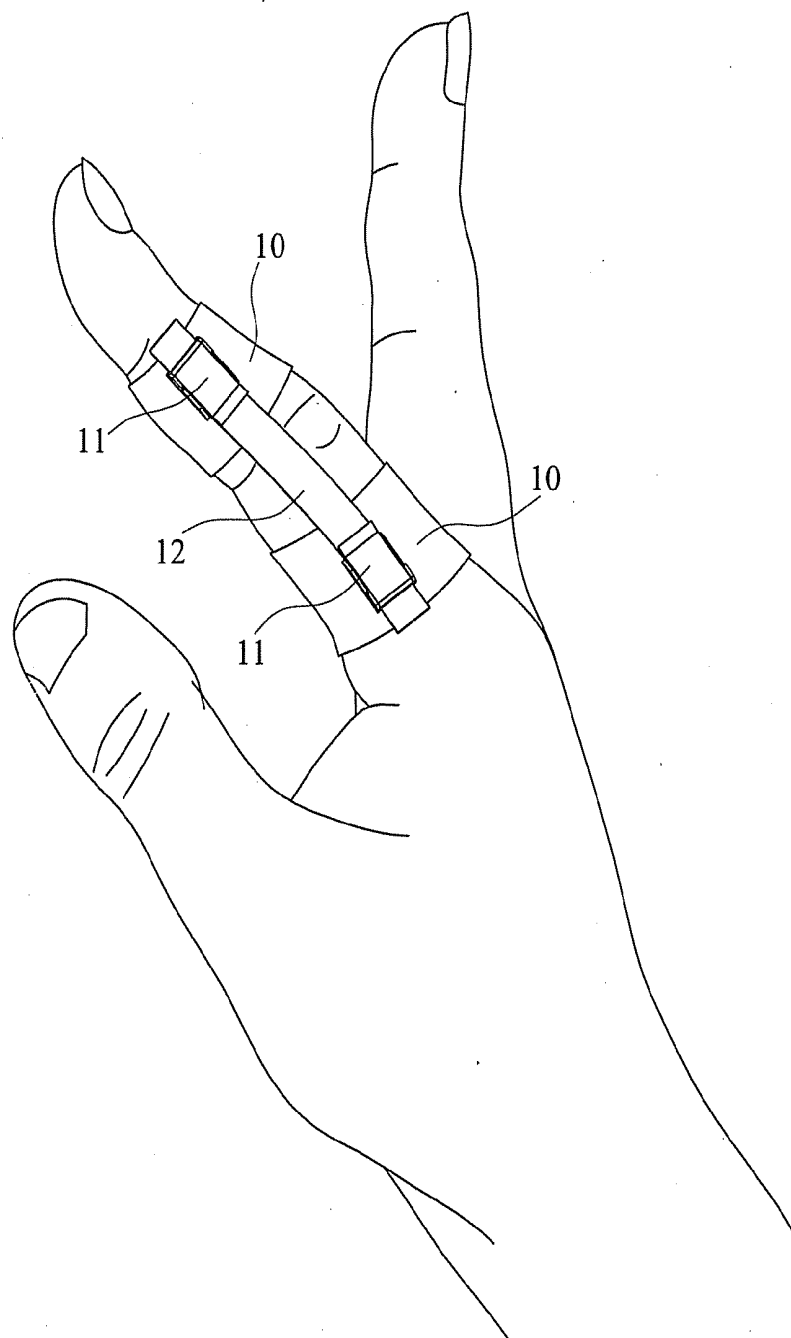

FIG. 1D

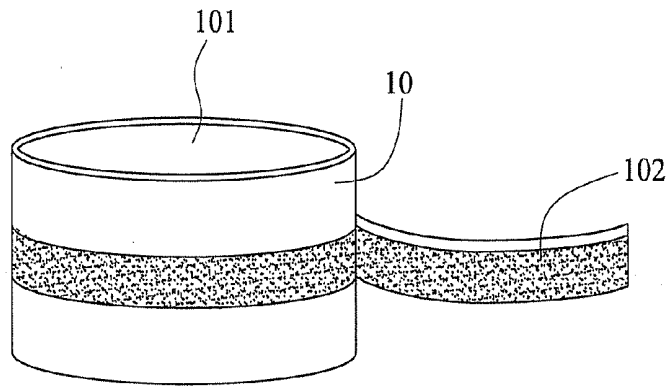

FIG. 1E

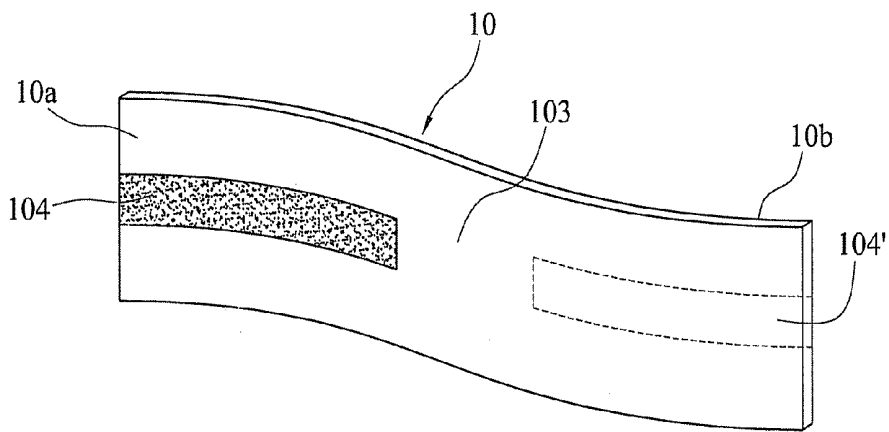

FIG. 1F

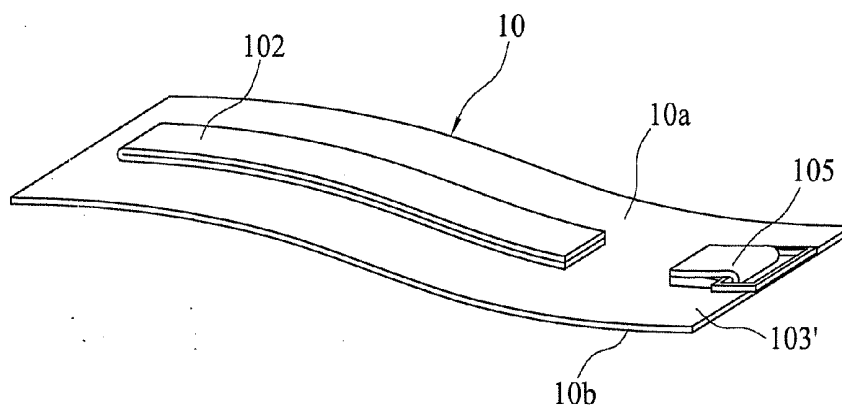

FIG. 1G

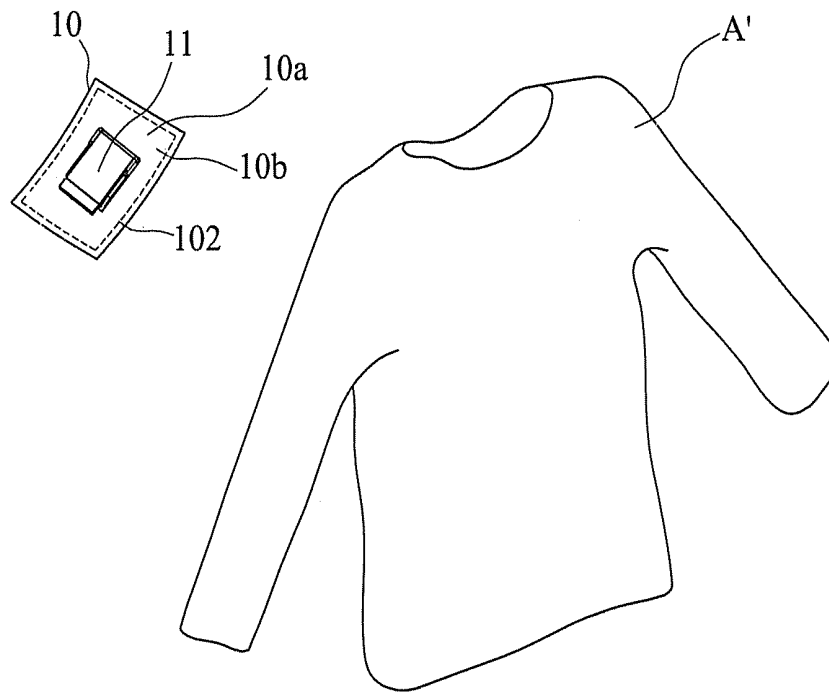

FIG. 1H

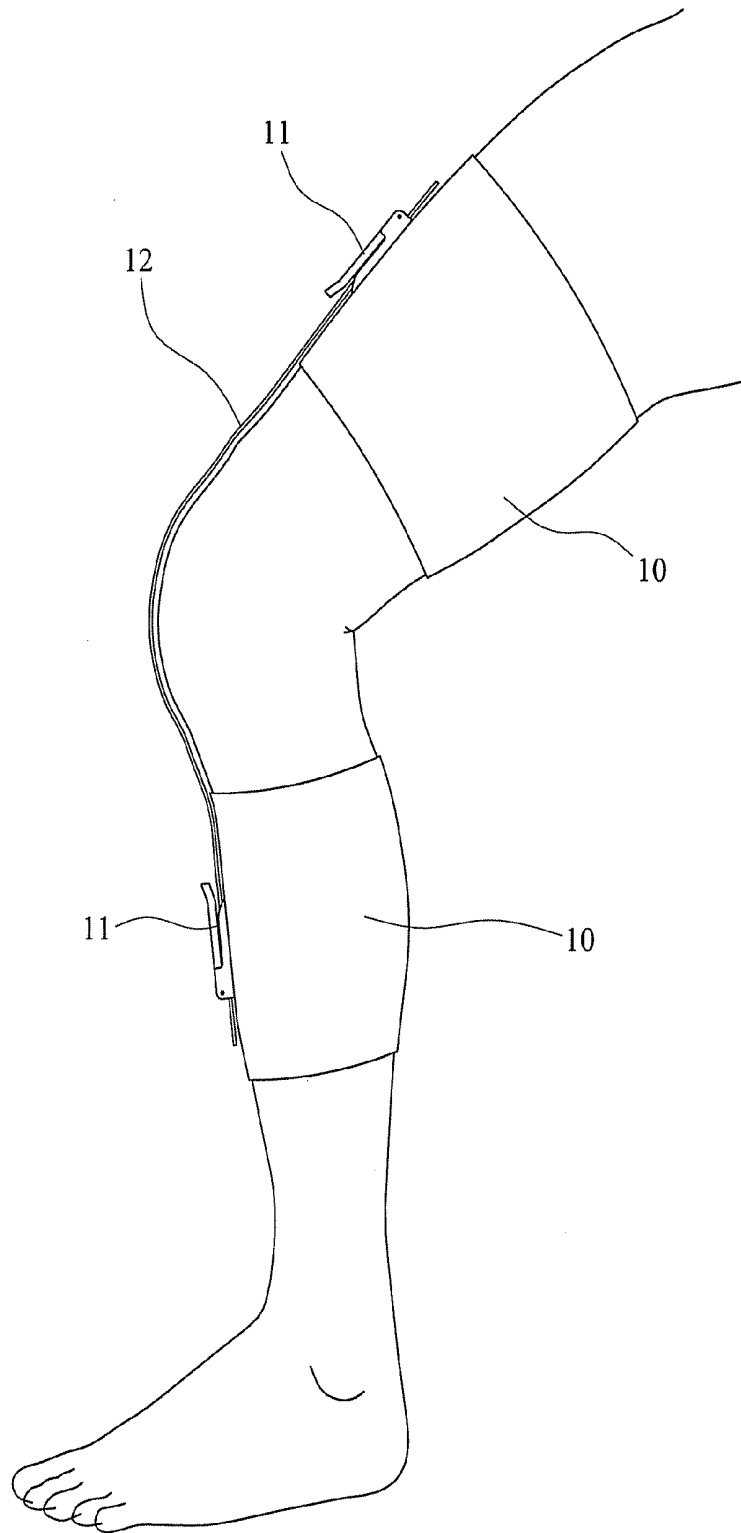

FIG. 11

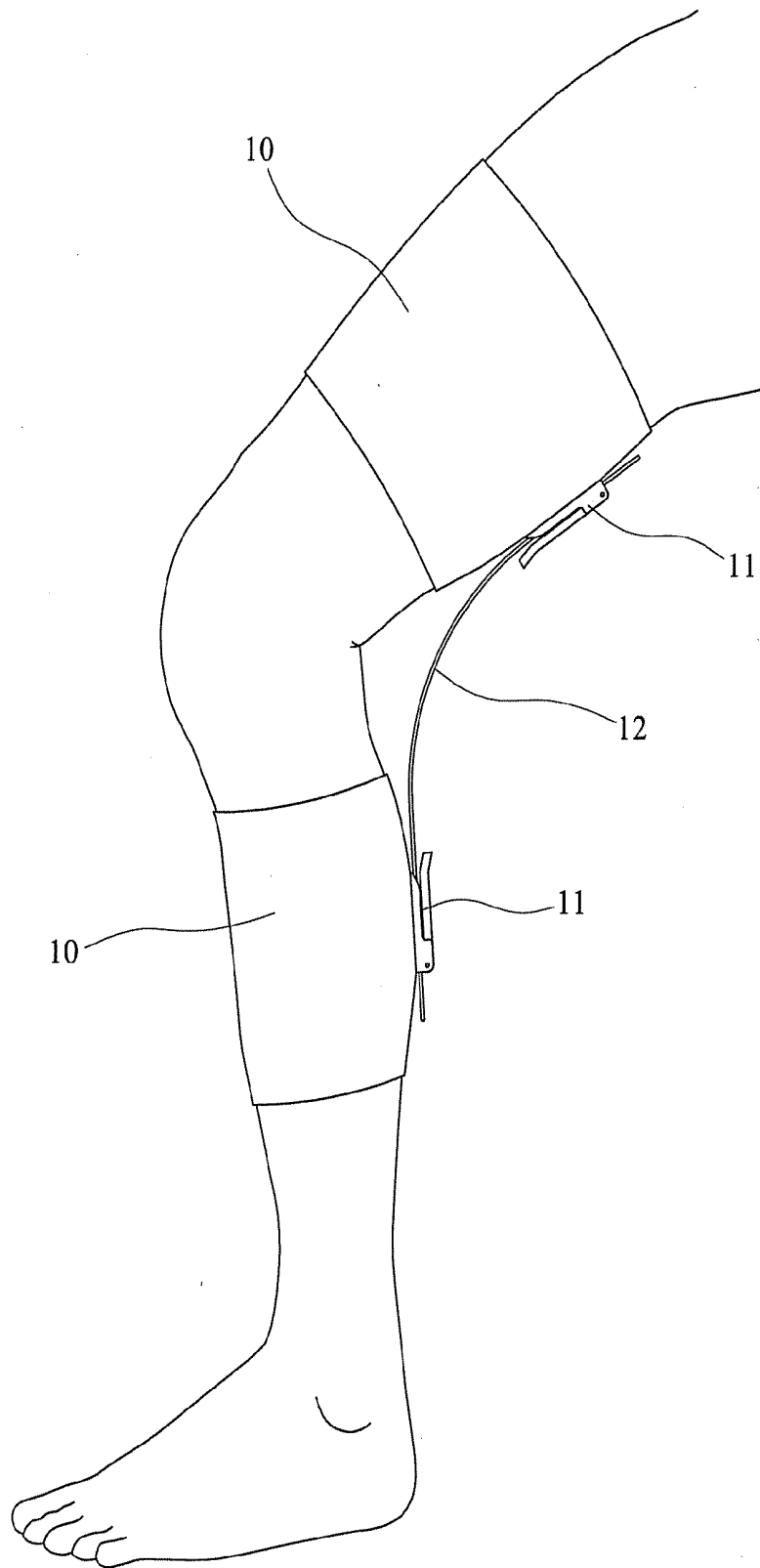

FIG. 1J

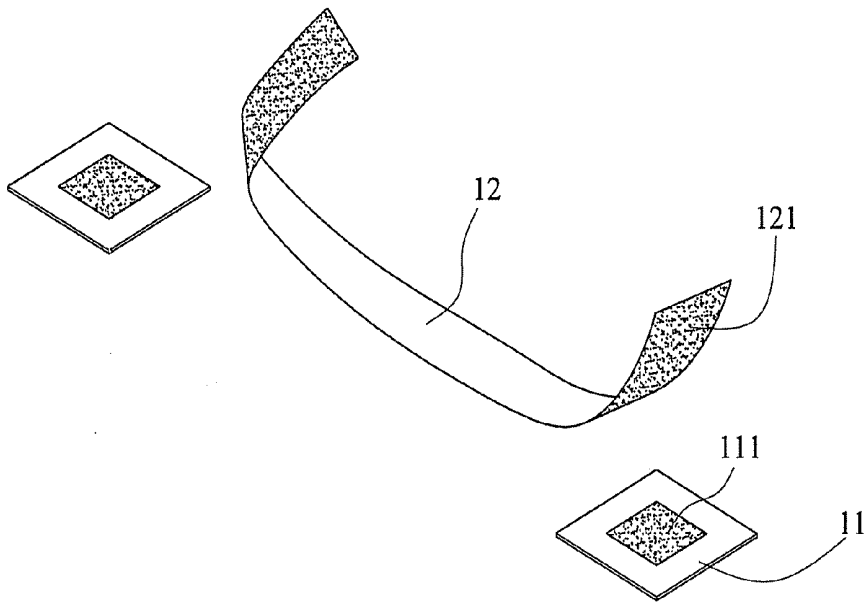

FIG. 1K

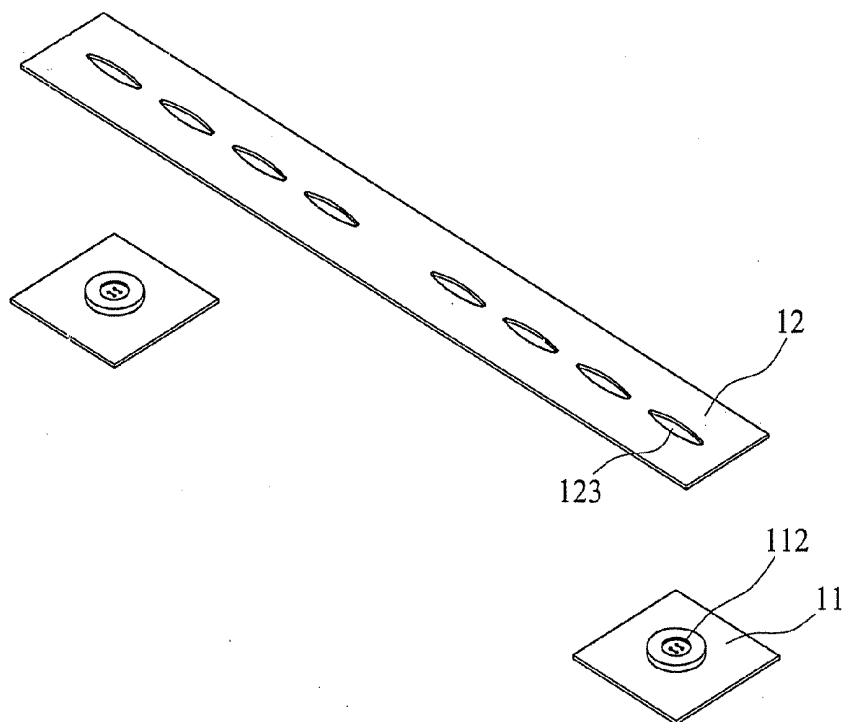

FIG. 1L

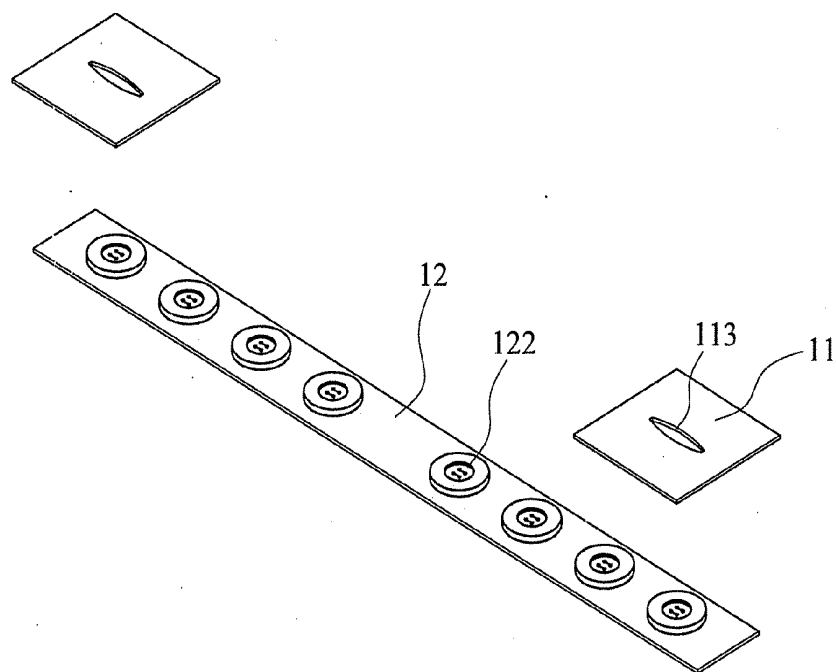

FIG. 1L'

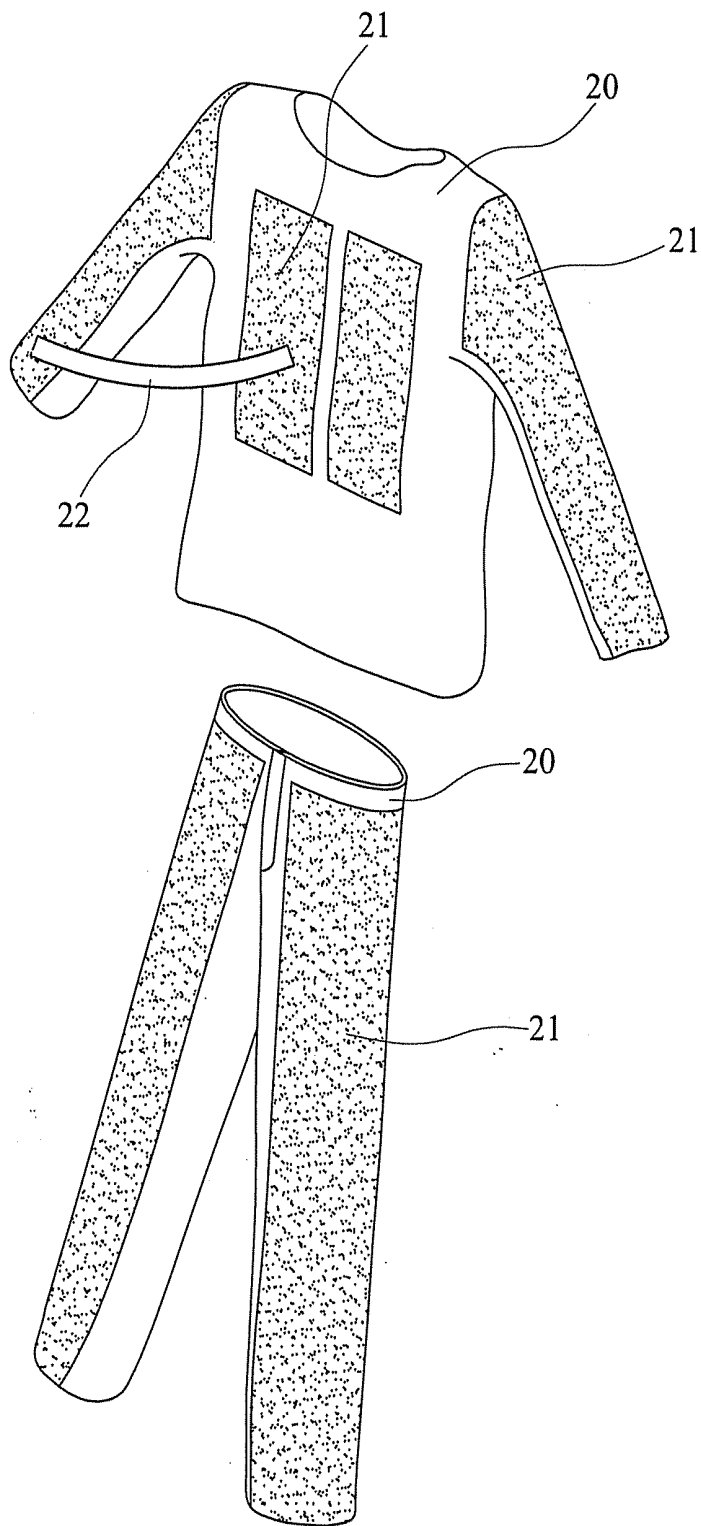

FIG. 2

MUSCULATURE TRAINING DEVICE**BACKGROUND OF THE INVENTION**

[0001] 1. Field of the Invention

[0002] This invention relates to training devices, and, more particularly, to a portable musculature training device.

[0003] 2. Description of Related Art

[0004] For fitness and health reasons, people get to spend more time on musculature training. A conventional musculature training device is heavy and bulky. Therefore, people cannot train themselves unless they stay at a certain place where the musculature training device is installed.

[0005] The conventional musculature training device requires a user's body to prop against an external device (e.g., wall, pole, or pillar), which is with high potential of injuries to the user. The conventional musculature training device usually provides constant resistance coefficient, which may not be suitable for all kinds of people, for example, athletes, ordinary persons, senior citizens, and patients. In the conventional musculature training device, the tubing set is fixed by a grip handle or a pedal, and cannot be fixed to a user's limbs. Accordingly, the user is likely to have his hands get hurt or his foot suffer plantar arch collapse. The conventional musculature training device generates joint load resistance that is applied to multiple joints (e.g., shoulder joints, elbow joints and wrist joints), and cannot be applied to musculature of a certain joint.

[0006] Therefore, there is a need to provide a musculature training device that can be steadily fixed to a user's body or limbs, needs no external device, is suitable all kinds of people, and is used to train the musculature of a certain joint.

SUMMARY OF THE INVENTION

[0007] The present invention provides a musculature training device, including an attaching member fixed around a joint of a user's body or limbs; at least a fixing-and-adjusting member installed on the attaching member that is disposed on two sides of the joint; and at least an elastic member coupled to the fixing-and-adjusting member, wherein the fixing-and-adjusting member sets an initial length of the elastic member, and when the body or the limbs move to deform the elastic member and change the initial length of the elastic member, the elastic member generates a restoring force that provides a resistance needed for musculature training around the joint.

[0008] The present invention further provides a musculature training device, including a training cloth; a plurality of fixing-and-adjusting members coupled with the training cloth and disposed on two sides of a joint of a user's body or limbs; and at least an elastic member having two ends connected to the fixing-and-adjusting members that are disposed at two side of the joint, wherein the fixing-and-adjusting members set an initial length of the elastic member, and when the body or the limbs move to deform the elastic member and change the initial length of the elastic member, the elastic member generates a restoring force that provides a resistance needed for musculature training around the joint.

[0009] Compared with the prior art, the present invention provides a musculature training device that has an adjustable attaching member having an initial length and a fixing-and-adjusting member that can be fixed to a corresponding position of a user's body or limbs. Therefore, a training resistance with different strength is provided, sport injury is avoided, and training effectiveness is improved.

BRIEF DESCRIPTION OF DRAWINGS

[0010] The invention can be more fully understood by reading the following detailed description of the preferred embodiments, with reference made to the accompanying drawings, wherein:

[0011] FIGS. 1A to 1L' are schematic diagrams illustrating a musculature training device according to an embodiment of the present invention; and

[0012] FIG. 2 is a schematic diagram showing a musculature training device according to another embodiment of the present invention.

DETAILED DESCRIPTION OF THE INVENTION

[0013] The following illustrative embodiments are provided to illustrate the disclosure of the present invention, these and other advantages and effects can be apparently understood by those in the art after reading the disclosure of this specification. The present invention can also be performed or applied by other different embodiments. The details of the specification may be on the basis of different points and applications, and numerous modifications and variations can be devised without departing from the spirit of the present invention.

[0014] FIG. 1A is a schematic diagram showing a musculature training device **1** according to an embodiment of the present invention. The musculature training device **1** comprises an attaching member **10**, at least a fixing-and-adjusting member **11**, and at least an elastic member **12**.

[0015] The attaching member **10** is fixed around a joint of a user's body or limbs, and can be adjusted according to the dimension of the limbs, to satisfy the musculature training demands for different body parts. With regard to the musculature training for knee joints, for example, the attaching member **10** is fixed at a first position, which is $\frac{1}{3}$ of the length of the thigh away from the knee and a second position, which is $\frac{1}{3}$ of the length of the shank away from the knee, as shown in FIG. 1B. With regard to the musculature training for elbow joints, the attaching member **10** is fixed at a first position, which is $\frac{1}{3}$ of the length of the upper arm away from the elbow and a second position, which is $\frac{1}{3}$ of the length of the forearm away from the elbow, as shown in FIG. 1C. With regard to the musculature training for finger joints, the attaching member **10** is fixed to a finger tip and a proximal phalanx, as shown in FIG. 1D.

[0016] In an embodiment, the attaching member **10** is a ring-shaped girdle that has a through hole **101** for a user A's body or limbs to pass therethrough, and an engaging portion **102** for adjusting the size of the through hole **101**, as shown in FIG. 1E.

[0017] In another embodiment, the attaching member **10** is a cloth strip **103** that has a first surface **10a**, a second surface **10b** opposing to the first surface **10a**, a first engaging portion **104** disposed on the first surface **10a**, and a second engaging portion **104'** disposed on the second surface **10b**, for the user to fix the attaching member **10** to his body or limbs by engaging the first engaging portion **104** with the second engaging portion **104'**, as shown in FIG. 1F.

[0018] In yet another embodiment, the attaching member **10** is another cloth strip **103'** that has a first surface **10a**, a second surface **10b** opposing to the first surface **10a**, and an engaging portion **102** and a buckle **105** that are disposed on the first surface **10a**, for the user to fix the attaching member **10** to his body or limbs with the second surface **10b** adhered

to his body or limbs and the engaging portion **102** surrounding the body or limbs and engaged with the buckle **105**, as shown in FIG. 1G.

[0019] In yet another embodiment, the attaching member **10** has a first surface **10a** coupled with the fixing-and-adjusting member **11**, a second surface **10b** opposing to the first surface **10a**, and an engaging portion **102** disposed on the second surface **10b**, for the user to fix the attaching member to a cloth **A'** wore on his body or limbs, as shown in FIG. 1H.

[0020] The at least a fixing-and-adjusting member **11** is installed on the attaching member **10** that is disposed on two sides of the joint.

[0021] In an embodiment, the fixing-and-adjusting member **11** is a clamp buckle, a slide buckle or a cam buckle.

[0022] The at least an elastic member **12** is coupled with the fixing-and-adjusting member **11**. An initial length of the elastic member **12** is set by the fixing-and-adjusting member **11**. When the user moves his body or limbs to deform the elastic member **12** and change the initial length of the elastic member **12**, the elastic member **12** generates a restoring force that provides resistance needed for musculature training around the joint. The shorter the initial length is, the greater the restoring force generated by the elastic member **12** becomes. Therefore, the user may select suitable training strength on his demands. In an embodiment, the elastic member **12** is a tubing, a thera-band, a spring or a metal sheet.

[0023] In an embodiment, at least two fixing-and-adjusting members **11** are installed on the attaching member **10** that is disposed on two sides of the joint, and two ends of the elastic member **12** are coupled with fixing-and-adjusting members **11**, respectively, that are installed on two side of the joint.

[0024] In another embodiment, the fixing-and-adjusting member **11** that is coupled with one end of the elastic member **12** is disposed on the attaching member **10**, which is disposed on one side of the joint, and the other end of the elastic member **12** is coupled with the attaching member **10** that is disposed on the other side of the joint.

[0025] In yet another embodiment, the elastic member **12** is deformed when being pulled, compressed, bended or twisted.

[0026] In yet another embodiment, the user is allowed to dispose the fixing-and-adjusting member **11** or the elastic member **12** on certain positions corresponding to the musculature to be trained. The elastic member **12** is deformed as the musculature to be trained contracts. With regard to the training of quadriceps femoris at the front side of thigh, the fixing-and-adjusting member **11** is fixed at the thigh and the front side of the shank, as shown in FIG. 1I. With regard to the training of biceps femoris at the rear side of thigh, the fixing-and-adjusting member **11** is fixed at the thigh and the rear side of the shank, as shown in FIG. 1J.

[0027] In another embodiment, the fixing-and-adjusting member **11** is used to adjust the initial length of the elastic member **12**, such that the elastic member **12** provides the resistance needed for musculature training of various strength.

[0028] In yet another embodiment, the elastic member **12** can be in parallel to or interlaced with a motion direction of the joint by changing the positions where the two ends of the elastic member **12** are coupled with the fixing-and-adjusting member **11**, to form force arms with different length and change the magnitude of the resistance.

[0029] In yet another embodiment, a user may select an elastic member **12** with a different resistance coefficient or change a number of the elastic members **12** on his demands.

It is recommended that an elastic member **12** with a low resistance coefficient is selected for muscle strength training, and another elastic member **12** with a high resistance coefficient is selected for muscular endurance training

[0030] In another embodiment, the fixing-and-adjusting member **11** has a first engaging portion **111**, and the elastic member **12** has a second engaging portion **121** extending along a length thereof. The initial length of the elastic member **12** can thus be adjusted by adjusting a position where the second engaging portion **121** is engaged with the first engaging portion **111**, as shown in FIG. 1K.

[0031] In yet another embodiment, the fixing-and-adjusting member **11** is a button **112** or a button hole **113**, and the elastic member **12** has a plurality of button holes **123** or buttons **122** disposed along a length thereof. Accordingly, a user can adjust the initial length of the elastic member **12** by engaging the fixing-and-adjusting member **11** with one of the button holes **123** or the buttons **122**, as shown in FIGS. 1L and 1L', respectively.

[0032] FIG. 2 is a schematic diagram showing a musculature training device **2** according to another embodiment of the present invention. The musculature training device **2** comprises at least a training cloth **20**, a plurality of fixing-and-adjusting members **21**, and at least an elastic member **22**. The musculature training device **2** differs from the musculature training device **1** in that the fixing-and-adjusting members **21** of the musculature training device **2** are coupled with the training cloth **20**, and are disposed on two sides of the joint of a user's body or limbs. With regard to the musculature training for knee joints, for example, the fixing-and-adjusting member **21** is disposed at a first position, which is $\frac{1}{3}$ of the length of the thigh away from the knee and a second position, which is $\frac{1}{3}$ of the length of the shank away from the knee. With regard to the musculature training for elbow joints, the fixing-and-adjusting member **21** is fixed at a first position, which is $\frac{1}{3}$ of the length of the upper arm away from the elbow and a second position, which is $\frac{1}{3}$ of the length of the forearm away from the elbow.

[0033] In conclusion, since a musculature training device of the present invention includes an attaching member or a training cloth, a user may take rehabilitation treatment or strength training without worrying about getting injured. By contrast, the conventional weight training equipment such as 1 RM (repetition maximum) likely introduces sport injury.

[0034] Moreover, a musculature training device of the present invention has a fixing-and-adjusting member in cooperation with an elastic member, so as to change training resistance of musculature around a single joint, perform a certain joint sport, and act as an auxiliary device that is composed of active and passive body elements, such as muscles, joints and ligaments. Therefore, the musculature training device provides resistance against muscles, and provides athletes or patients with improved musculature training effectiveness. When a user is walking, the musculature training device provides light resistance training

[0035] The foregoing descriptions of the detailed embodiments are only illustrated to disclose the features and functions of the present invention and not restrictive of the scope of the present invention. It should be understood to those in the art that all modifications and variations according to the spirit and principle in the disclosure of the present invention should fall within the scope of the appended claims.

What is claimed is:

1. A musculature training device, comprising:
 - an attaching member for being fixed around a joint of a user's body or limbs;
 - at least a fixing-and-adjusting member installed on the attaching member that is disposed on two sides of the joint; and
 - at least an elastic member coupled to the fixing-and-adjusting member,
 wherein the fixing-and-adjusting member sets an initial length of the elastic member, and when the body or the limbs move to deform the elastic member and change the initial length of the elastic member, the elastic member generates a restoring force that provides a resistance needed for musculature training around the joint.
2. The musculature training device of claim 1, wherein the at least a fixing-and-adjusting member includes two fixing-and-adjusting members to be installed on the attaching member that is disposed on two side of the joint, and the elastic member has two ends coupled to the two fixing-and-adjusting members, respectively.
3. The musculature training device of claim 1, wherein the fixing-and-adjusting member coupled to one end of the elastic member is disposed on the attaching member that is disposed on one side of the joint, and the other end of the elastic member is coupled to the attaching member that is disposed on the other side of the joint.
4. The musculature training device of claim 1, wherein the fixing-and-adjusting member or the elastic member is disposed at a specific position that corresponds to musculature to be trained, allowing the elastic member to be deformed and to provide the resistance needed for the musculature training as the musculature to be trained contracts.
5. The musculature training device of claim 1, wherein the elastic member is deformed when being pulled, compressed, bended or twisted.
6. The musculature training device of claim 1, wherein the attaching member is a ring-shaped girdle that has a through hole for the user's body or limbs to pass therethrough, and an engaging portion for adjusting sizes of the through hole.
7. The musculature training device of claim 1, wherein the attaching member is a cloth strip having a first surface, a second surface opposing to the first surface, a first engaging portion disposed on the first surface, and a second engaging portion disposed on the second surface, allowing the cloth strip to surround and be fixed to the body or the limbs by engaging the first engaging portion with the second engaging portion.
8. The musculature training device of claim 1, wherein the attaching member has a first surface, a second surface opposing to the first surface, and an engaging portion disposed on the first surface, allowing the second surface to be bonded or fixed to the body or limbs and the engaging portion to surround and be fixed to the body or the limbs.
9. The musculature training device of claim 1, wherein the attaching member has a first surface that is coupled to the fixing-and-adjusting member, a second surface opposing to the first surface, and an engaging portion disposed on the second surface that engages the attaching member to a cloth wore on the body or the limbs.
10. The musculature training device of claim 1, wherein the fixing-and-adjusting member is a clamp buckle, a slide buckle or a cam buckle.
11. The musculature training device of claim 1, wherein the fixing-and-adjusting member has a first engaging portion, the elastic member has a second engaging portion extending along a length thereof, and the initial length of the elastic member is adjusted by adjusting the position where the second engaging portion is engaged with the first engaging portion.
12. The musculature training device of claim 1, wherein the fixing-and-adjusting member is a button or a button hole, and the elastic member has a plurality of corresponding button holes or buttons disposed along a length thereof, allowing the initial length of the elastic member to be adjusted by engaging the fixing-and-adjusting member with one of the button holes or the buttons.
13. The musculature training device of claim 1, wherein the elastic member is a tubing, a thera-band, a spring or a metal sheet.
14. A musculature training device, comprising:
 - a training cloth;
 - a plurality of fixing-and-adjusting members coupled with the training cloth and disposed on two sides of a joint of a user's body or limbs; and
 - at least an elastic member having two ends connected to the fixing-and-adjusting members,
 wherein the fixing-and-adjusting members set an initial length of the elastic member, and when the body or the limbs move to deform the elastic member and change the initial length of the elastic member, the elastic member generates a restoring force that provides a resistance needed for musculature training around the joint.
15. The musculature training device of claim 14, wherein the fixing-and-adjusting members or the elastic member is disposed at a specific position that corresponds to musculature to be trained, allowing the elastic member to be deformed and to provide the resistance needed for the musculature training as the musculature to be trained contracts.
16. The musculature training device of claim 14, wherein the elastic member is deformed when being pulled, compressed, bended or twisted.
17. The musculature training device of claim 14, wherein the fixing-and-adjusting members are clamp buckles, slide buckles or cam buckles.
18. The musculature training device of claim 14, wherein the fixing-and-adjusting members have a first engaging portion, the elastic member has a second engaging portion extending along a length thereof, and the initial length of the elastic member is adjusted by adjusting the position where the second engaging portion is engaged with the first engaging portion.
19. The musculature training device of claim 14, wherein the fixing-and-adjusting members are buttons or button holes, and the elastic member has a plurality of corresponding button holes or buttons along a length thereof, allowing the initial length of the elastic member to be adjusted by engaging the fixing-and-adjusting member with one of the button holes or the buttons.
20. The musculature training device of claim 14, wherein the elastic member is a tubing, a thera-band, a spring or a metal sheet.