



US 20130115672A1

(19) **United States**

(12) **Patent Application Publication**
TSENG et al.

(10) **Pub. No.: US 2013/0115672 A1**

(43) **Pub. Date: May 9, 2013**

(54) **BIOLOGICAL COMPOSITE AND METHOD FOR REDUCING H₂S**

Publication Classification

(75) Inventors: **Ching-Ping TSENG**, Hsinchu City (TW); **Yu-Pei Chen**, New Taipei City (TW)

(51) **Int. Cl.**
C12N 11/14 (2006.01)
C12S 5/00 (2006.01)
C12N 1/21 (2006.01)
C12N 11/00 (2006.01)

(73) Assignee: **National Chiao Tung University**, Hsinchu City (TW)

(52) **U.S. Cl.**
USPC **435/176**; 435/174; 435/266; 435/252.3

(21) Appl. No.: **13/418,005**

(57) **ABSTRACT**

(22) Filed: **Mar. 12, 2012**

(30) **Foreign Application Priority Data**

Nov. 8, 2011 (TW) 100140774

A biological composite and method for reducing H₂S are disclosed. The biological composite for reducing H₂S includes a carrier and *Thermus* sp. immobilized on the carrier. Therefore, if a sample containing H₂S has contact with *Thermus* sp. or the carrier with *Thermus* sp. immobilized thereon, the amount of H₂S can be reduced.

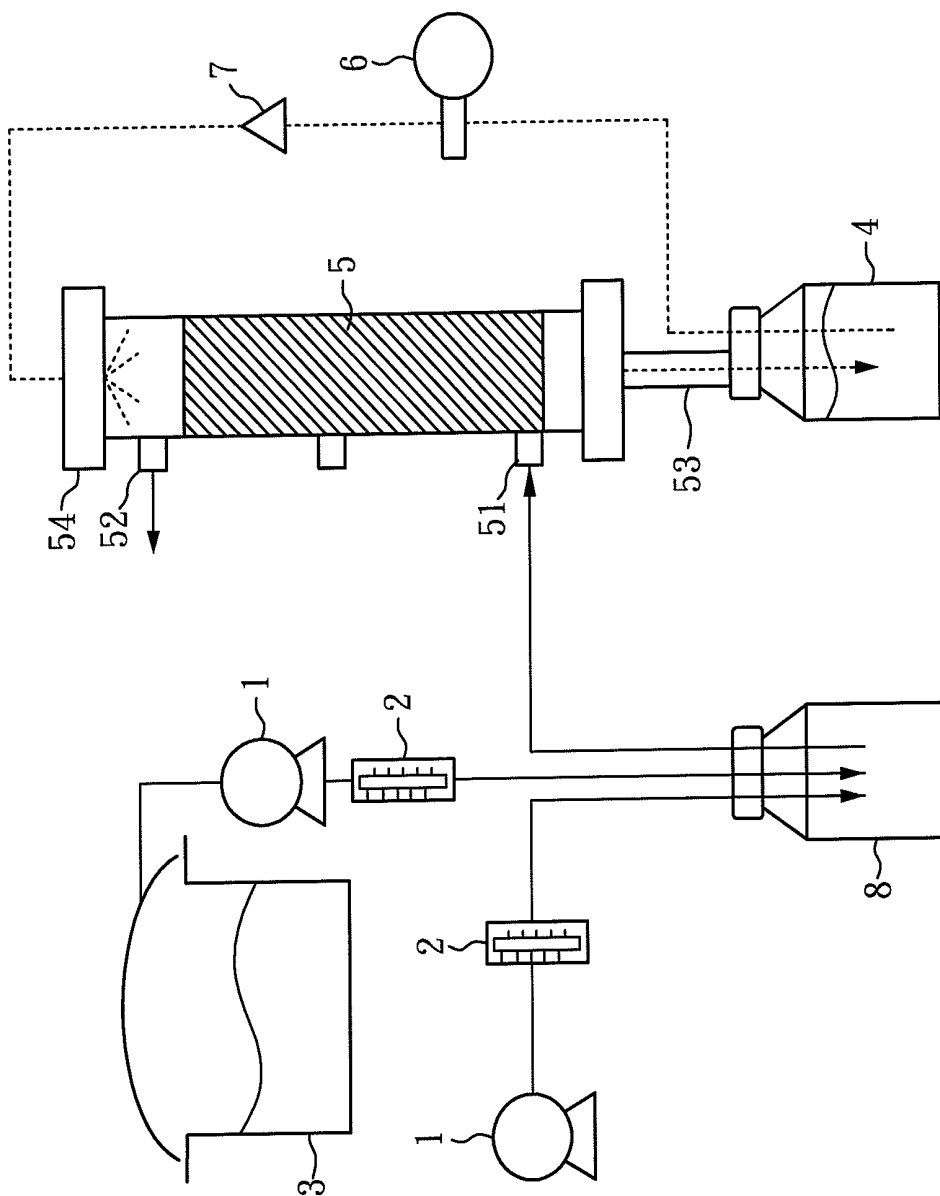

FIG. 1

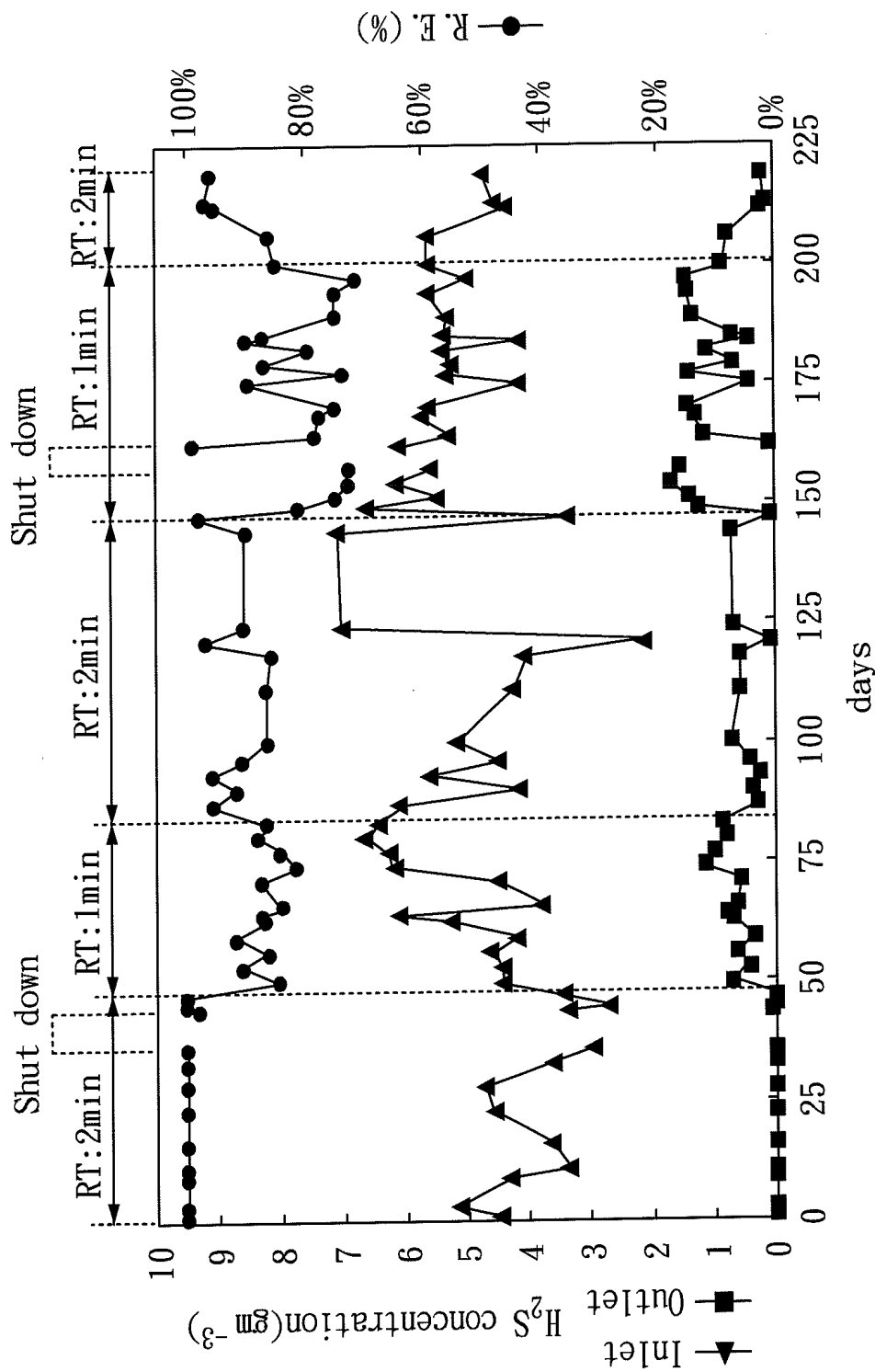

FIG. 2

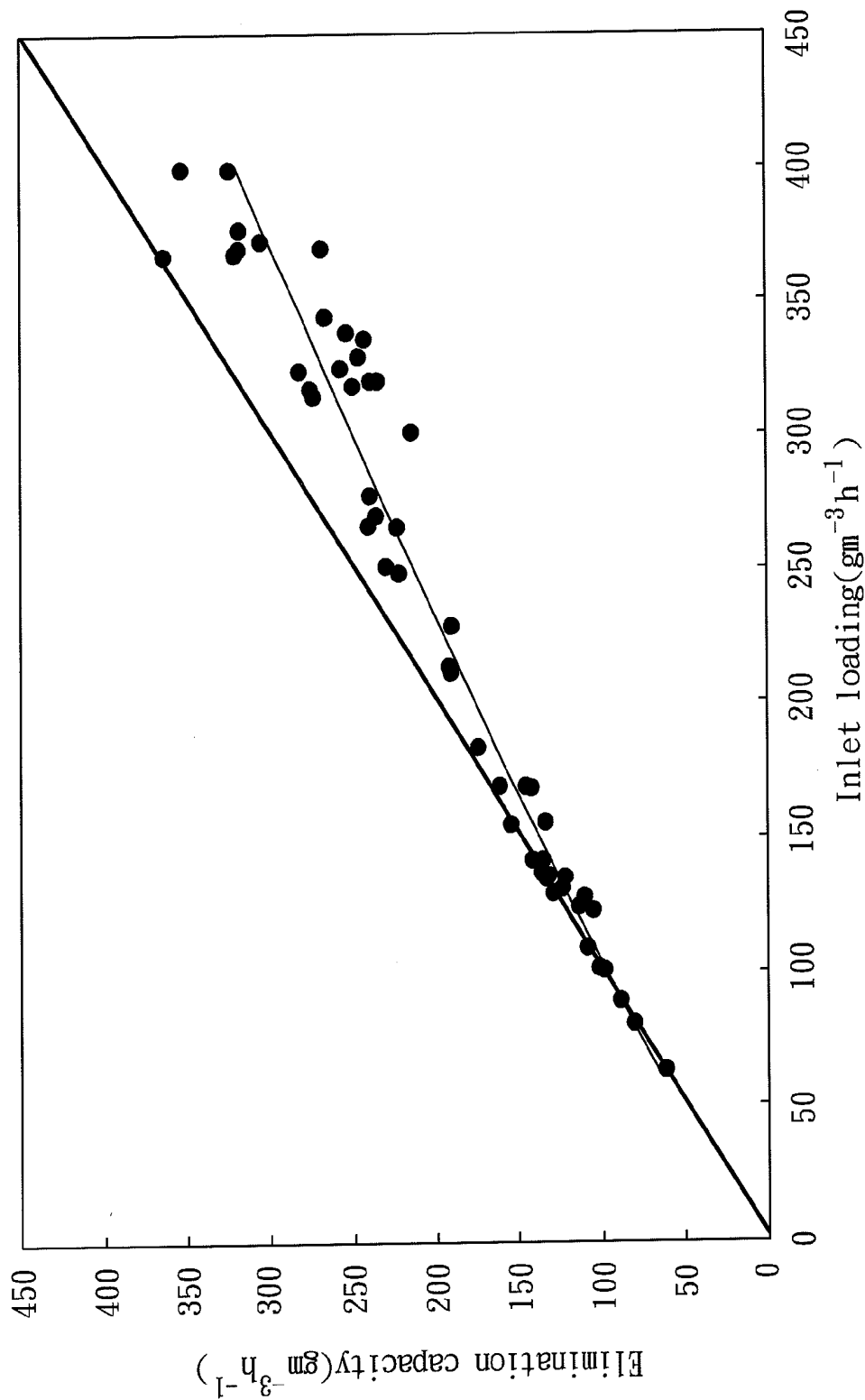

FIG. 3

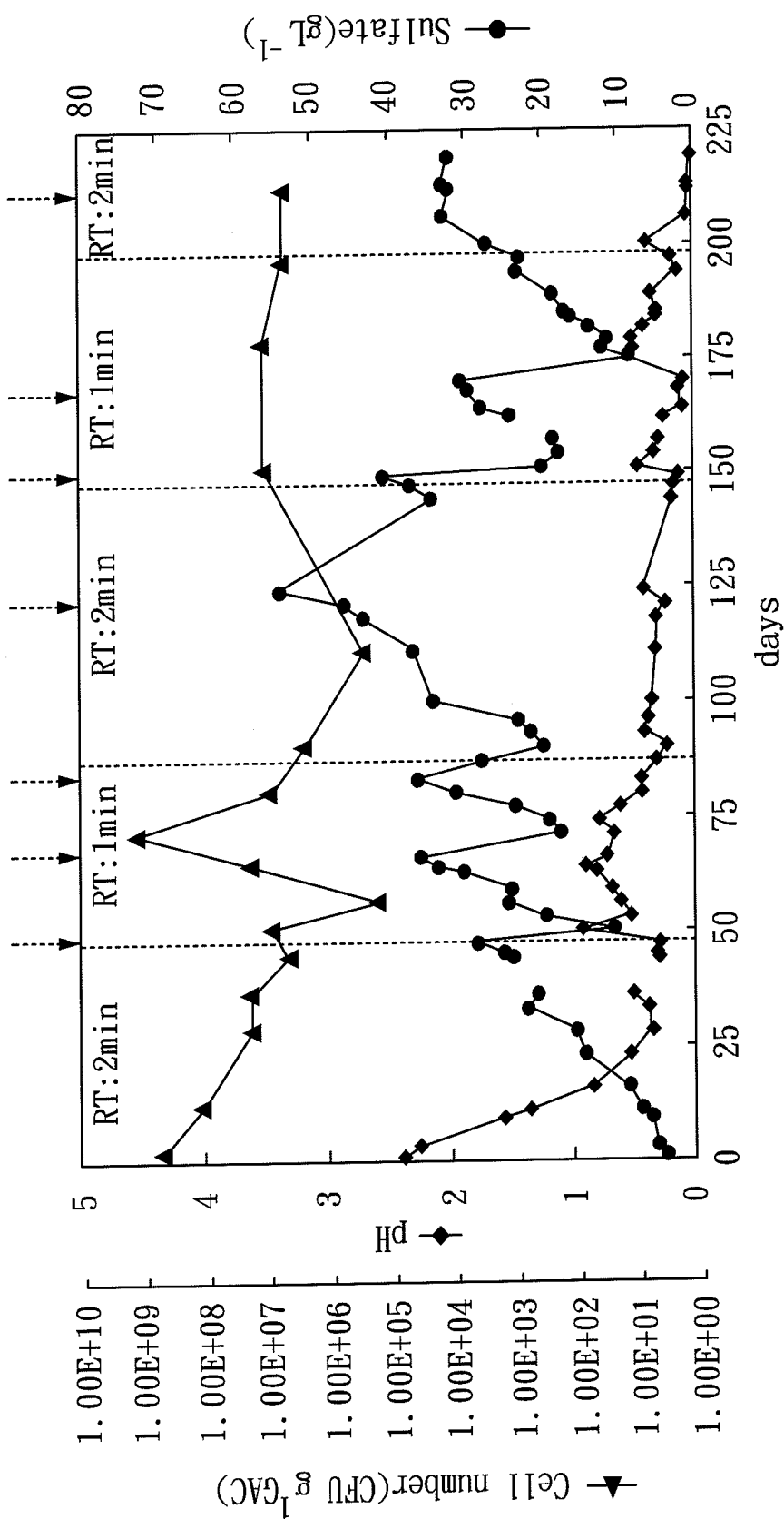

FIG. 4

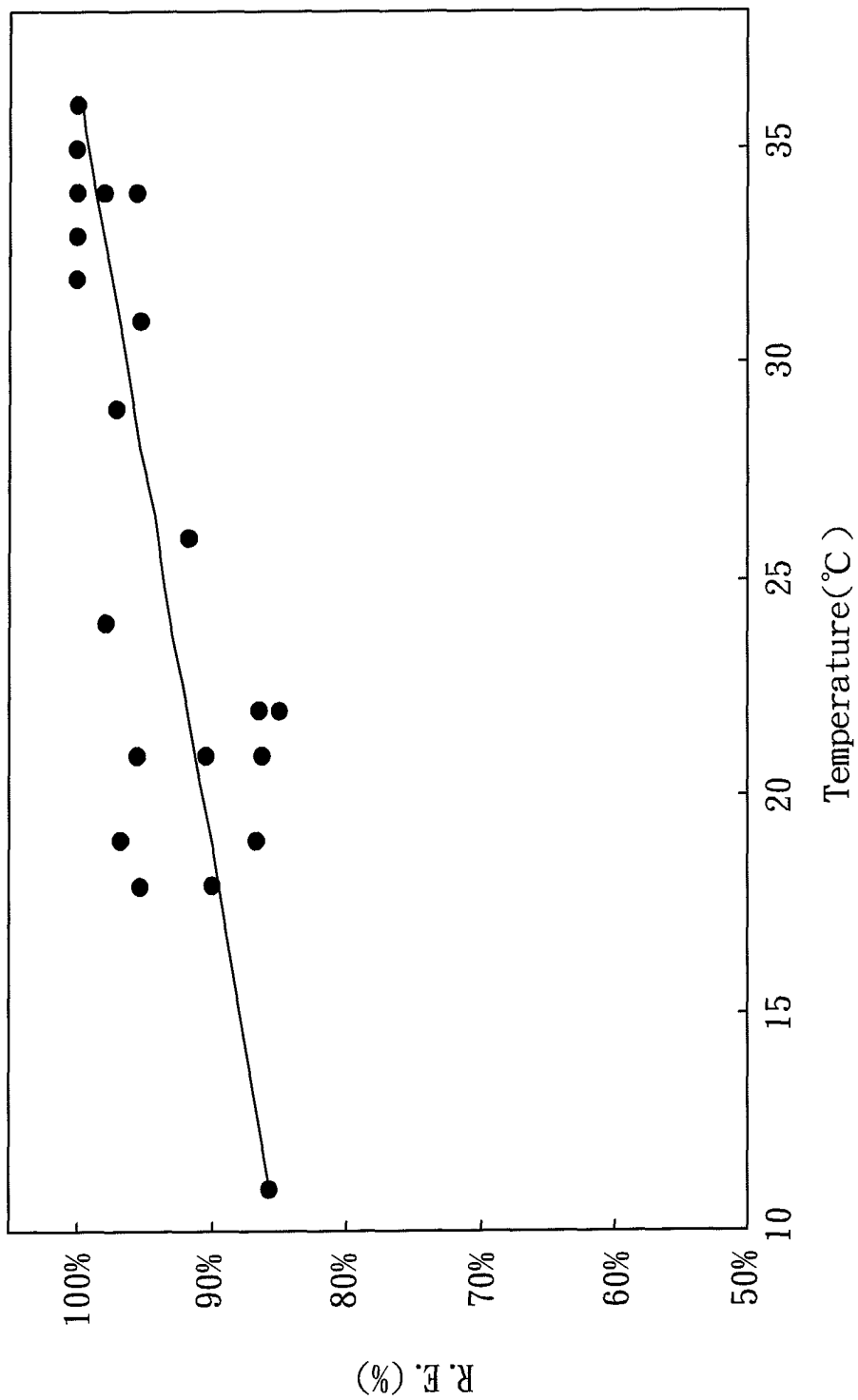

FIG. 5

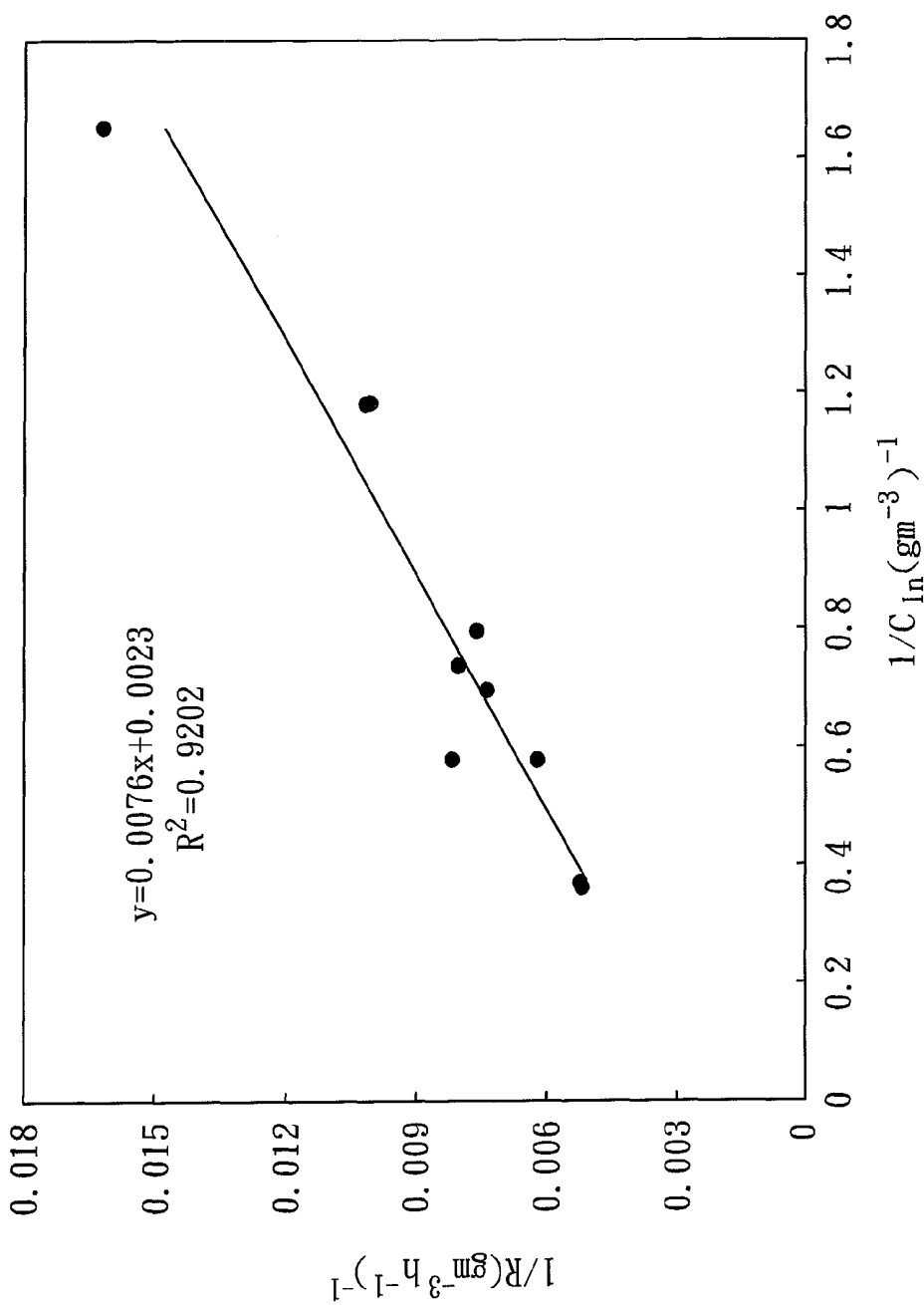

FIG. 6

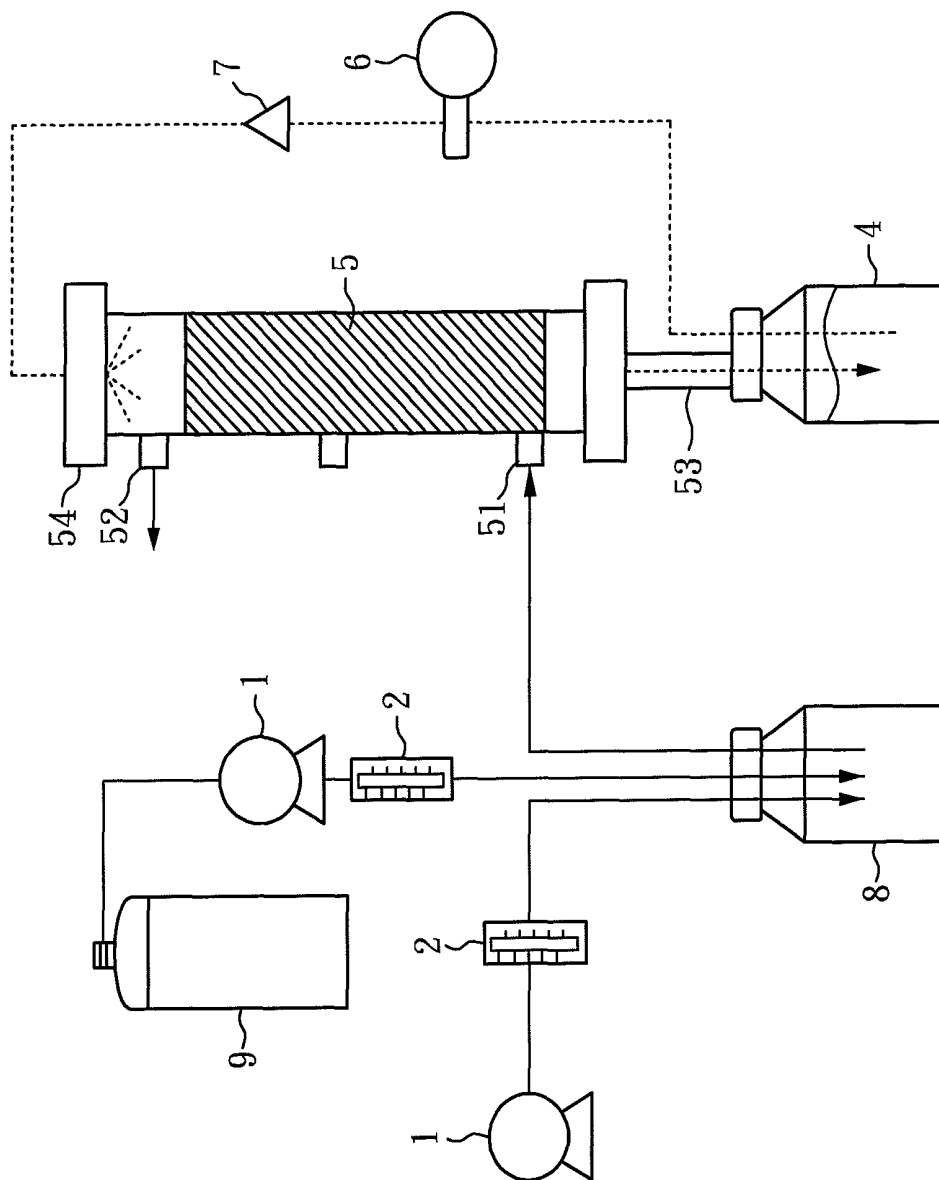

FIG. 7

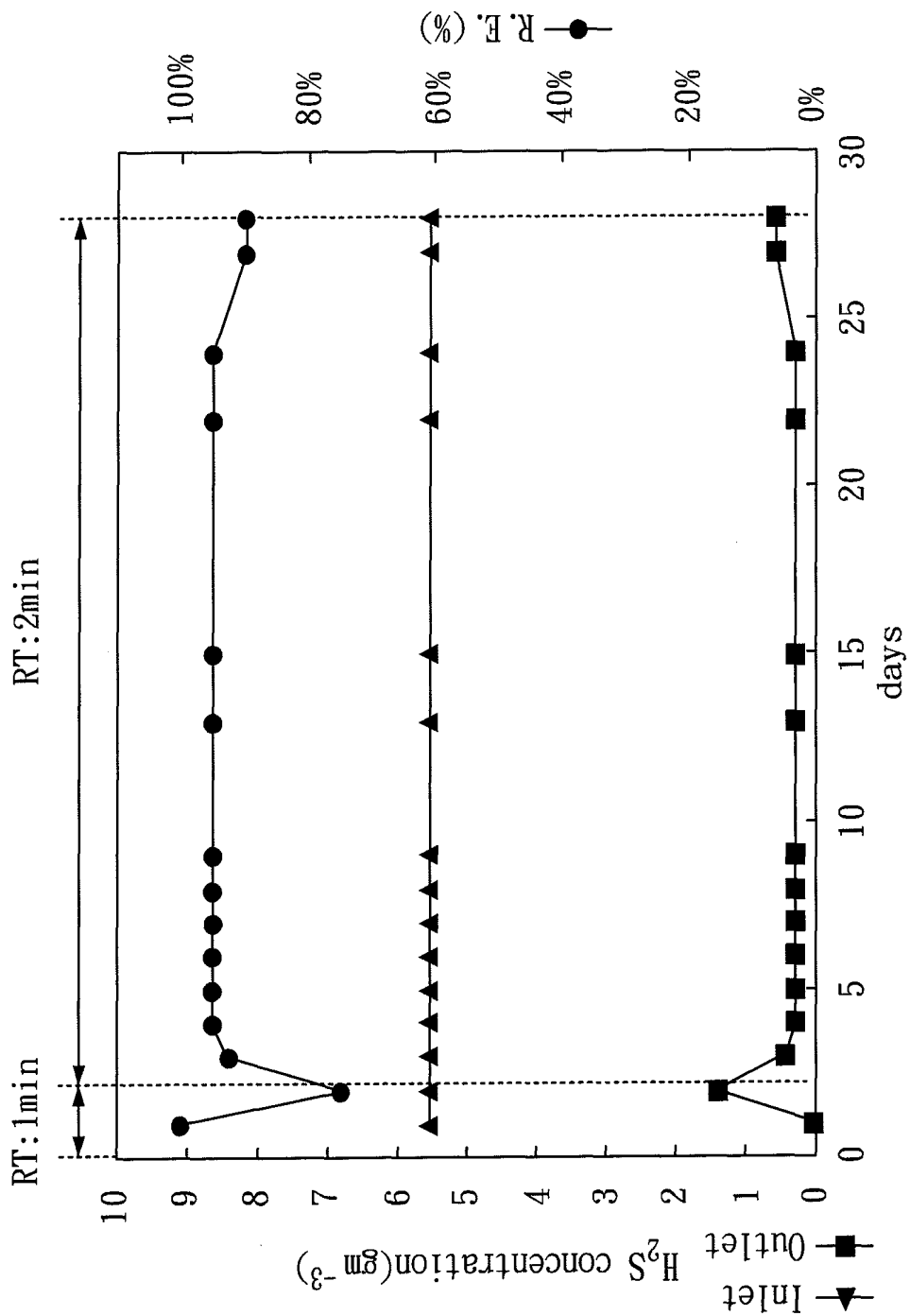

FIG. 8

BIOLOGICAL COMPOSITE AND METHOD FOR REDUCING H₂S

CROSS REFERENCE TO RELATED APPLICATION

[0001] This application claims the benefits of the Taiwan Patent Application Serial Number 100140774, filed on Nov. 8, 2011, the subject matter of which is incorporated herein by reference.

BACKGROUND OF THE INVENTION

[0002] 1. Field of the Invention

[0003] The present invention relates to a biological composite and a method for reducing H₂S.

[0004] 2. Description of Related Art

[0005] Biogas from a wastewater treatment plant is classified as a cheap and environmentally friendly renewable energy, and can be applied as a source of alternative vehicle fuel or in generation of heat, electricity, and chemical compounds. Generally, such biogas contains 65% methane, 30% CO₂, 4% N₂, 0.2% H₂S, and other minor gases. Notably, H₂S is found in production of biogas and natural gas, or in the process of papermaking or oil-refining. When the accumulation of H₂S reaches a concentration up to 1000 ppm or more, it causes serious erosion to machines such as dynamos, and can be lethal to humans. Therefore, there is a need to reduce H₂S as much as possible in relevant processes.

[0006] Currently, methods for removing gaseous H₂S are mainly physical methods; incineration, Claus process, chemical washing; as well as biological methods. Except for biological methods, the others require high costs due to replacement of consumable materials or setting up of equipment. However, even in biological methods, there are still limitations in the treatment of H₂S up to 1000 ppm or more, depending on oxidative activity of different microbes to H₂S. Besides, when H₂S is oxidized into H₂SO₄ by microbes, H₂SO₄ is accumulated and makes the environmental pH value decrease. Accordingly, the growth and activity of the microbes are undesirably influenced, thereby resulting in decreased removal of H₂S.

[0007] Therefore, there is a need to find a microbe with extremely strong capacity for H₂S oxidation. Even if the environmental pH value is decreased, the microbe should be able to retain good oxidative activity to H₂S and thus it is advantageous to promote the environmental control development efforts within the papermaking and oil-refining industries as well as in the production of biogas and natural gas.

SUMMARY OF THE INVENTION

[0008] The object of the present invention is to provide a biological composite and a method for reducing H₂S. They can be applied to reduce the H₂S amount in related industries such as environmental and petrochemical industries, food engineering, and livestock farming so that serious erosion to machines and lethal injury to humans can be prevented.

[0009] To achieve the object, one aspect of the present invention provides a biological composite for reducing H₂S, comprising: a carrier; and *Thermus* sp. bacterium immobilized on the carrier.

[0010] Another aspect of the present invention provides a biological method for reducing H₂S, comprising the following step: making *Thermus* sp. bacterium in contact with a sample containing H₂S.

[0011] In the biological method for reducing H₂S mentioned in the present invention, the *Thermus* sp. bacterium can be immobilized on a carrier. Thus, if the carrier has contact with the H₂S-containing sample, the amount of H₂S can be reduced.

[0012] In the biological method and composite for reducing H₂S mentioned in the present invention, the carrier can be activated carbon, peat soil, compost, bark, vermiculite, oyster shell, zeolite, porphyritic andesite, iron hydroxide, active alumina, pearlite, snakewood, artificially synthesized chemical materials, or a combination thereof. Among them, the artificially synthesized chemical materials can be high molecular weight polymers such as polyethylene foam and Styrofoam. The *Thermus* sp. bacterium can form a biofilm encompassing the carrier, or form a biofilm along the outside and the inner pores of the carrier.

[0013] Still another aspect of the present invention provides an acidophilic sulfide-oxidizing bacterium, which is *Thermus* sp. bacterium and of which 16S rDNA sequence comprises SEQ ID NO. 3.

[0014] The bacterium was deposited on Oct. 19, 2011 and as BCRC 910527 in Bioresource Collection and Research Center in Hsinchu, Taiwan.

[0015] In addition to the bacterium mentioned above, the *Thermus* sp. bacterium can also be *Thermus scotoductus*.

[0016] In conclusion, during petrochemical oil-refining process, biogas and natural gas production, and papermaking process, H₂S accumulation can reach an amount more than 1000 ppm and thus cause erosion to machines or dynamos and be lethal to humans. However, the biological method and composite of the present invention can be applied to reducing H₂S in related industries as mentioned above. In other words, through the method and composite of the present invention, the *Thermus* sp. bacterium can transform H₂S gas into H₂SO₄ and retain desirable removal efficiency of H₂S in a low pH value, even when the environmental pH value decreases as H₂SO₄ accumulates. Accordingly, resource recovery such as purification of biogas and waste gas can be achieved.

[0017] Other objects, advantages, and novel features of the invention will become more apparent from the following detailed description when taken in conjunction with the accompanying drawings.

BRIEF DESCRIPTION OF THE DRAWINGS

[0018] FIG. 1 is a schematic diagram of a field biofilter employed in Examples 1 and 2 of the present invention;

[0019] FIG. 2 is a line chart of changes of H₂S concentration and removal efficiency (R.E. (%)) in Example 2 of the present invention, wherein the dot mark denotes removal efficiency of H₂S, the triangle mark denotes H₂S concentration at the inlet of the field biofilter, and the square mark denotes H₂S concentration at the outlet of the field biofilter;

[0020] FIG. 3 shows a line chart of the relationship between the inlet loading and the elimination capacity of H₂S in Example 2 of the present invention;

[0021] FIG. 4 shows a line chart of changes among pH value, cell number and sulfate concentration in Example 2 of the present invention, wherein the dot mark denotes sulfate concentration, the triangle mark denotes cell number, the rhombus mark denotes pH value, and the arrow mark means the time point of supplying fresh medium;

[0022] FIG. 5 shows a line chart of the relationship between the temperature and the removal efficiency of H₂S in Example

2 of the present invention, wherein the empty bed gas residence time (EBRT) is 2 minutes;

[0023] FIG. 6 shows a linear regression chart of $1/R$ vs. $1/C_{in}$ in kinetics analysis in Example 2 of the present invention, wherein the gas flow rate is controlled in 150 L/hr, biogas concentration ranges from 1,500 to 5,000 ppm, and EBRT is 2 minutes;

[0024] FIG. 7 is a schematic diagram of a lab-scaled field biofilter employed in Example 3 of the present invention; and

[0025] FIG. 8 shows a line chart of changes of H_2S concentration and removal efficiency in Example 3 of the present invention, wherein the dot mark denotes removal efficiency of H_2S , the triangle mark denotes H_2S concentration at the inlet of the field biofilter, and the square mark denotes H_2S concentration at the outlet of the field biofilter.

DETAILED DESCRIPTION OF THE PREFERRED EMBODIMENT

[0026] The inventors isolated an acidophilic microbe from swine sludge and found that it is tolerant of a low pH value and high H_2SO_4 concentration. Thus, it is expected that the microbe can achieve desirable removal efficiency of high H_2S concentration (>1000 ppm). Such acidophilic sulfide-oxidizing bacterium was classified into *Thermus* after identification and is able to transform H_2S into sulfate.

[0027] The acidophilic sulfide-oxidizing bacterium is cultured, proliferated, collected, concentrated, and then uniformly mixed with carriers or filters. The carriers or the filter materials are exemplified as peat soil, compost, bark, vermiculite, oyster shell, zeolite, porphyritic andesite, iron hydroxide, active alumina, pearlite, snake-wood, Styrofoam, polyethylene foam, and so on. The acidophilic sulfide-oxidizing bacterium is immobilized on the carriers or the filter materials (this step is commonly called as namely "immobilization"), and then their mixture forms biofilter materials having a biofilm. The biofilter materials can be applied to remove H_2S . For example, the biofilter materials can be deposited in a suitable container serving as a component of a biogas purification system.

[0028] In an example of the present invention, it is found that the average of the removal efficiency of H_2S reaches 95% within 219 days of long-term monitoring. Besides, because H_2S is oxidized into H_2SO_4 rather than being catalyzed into S, the biofilter can not be obstructed by S when biogas is purified. Also, the occurrence of gas short-circuiting can be prevented. In addition, as the time of the reaction is prolonged, accumulation of sulfate and decrease in pH value do not make the *Thermus* sp. bacterium of the present invention have lower activity of removing H_2S . Therefore, the removal efficiency of H_2S from biogas can be maintained.

[0029] Because of the specific embodiments illustrating the practice of the present invention, one skilled in the art can easily understand other advantages and efficiency of the present invention through the content disclosed therein. The present invention can also be practiced or applied by other variant embodiments. Many other possible modifications and variations of any detail in the present specification based on different outlooks and applications can be made without departing from the spirit of the invention.

[0030] The drawings of the embodiments in the present invention are all simplified charts or views, and only reveal elements relative to the present invention. The elements revealed in the drawings are not necessarily aspects of the

practice, and quantity and shape thereof are optionally designed. Further, the design aspect of the elements can be more complex.

Example 1

Isolation and Identification of Sulfide-Oxidizing Bacterium

[0031] All of the reagents, solutions, containers, and instruments were maintained in aseptic conditions during the following experimental period.

[0032] The acidic tolerance bacterium was isolated from swine sludge and cultured in the medium (glucose 5 g, $(NH_4)_2SO_4$ 3 g, KH_2PO_4 0.5 g, $MgSO_4 \cdot 7H_2O$ 0.5 g, KCl 0.1 g, $Ca(NO_3)_2$ 12.5 mg, and $FeSO_4 \cdot 7H_2O$ 0.01 mg in 1 liter) for 7 days and harvested by centrifugation ($7500 \times g$ for 10 min).

[0033] Commercially available granular activated carbon (GAC, Taiwan Activated Carbon Industries Company) obtained from coconut shell with a particle size of 4.5 mm was used as the support material for the immobilization of *Thermus* sp. CP1. The bulk density and the specific surface area of the support material were 0.48 g cm^{-3} and $1250 \text{ m}^2 \text{ g}^{-1}$, and the pH value thereof was adjusted to 3.0 by H_2SO_4 . In the present example, the support material is not limited to granular activated carbon, and it also can be peat soil, compost, bark, vermiculite, oyster shell, zeolite, porphyritic andesite, iron hydroxide, active alumina, pearlite, snake-wood, Styrofoam, polyethylene foam, and so forth.

[0034] The harvested bacterium was resuspended and evenly mixed with about 2.4 kg of pH-adjusted GAC in a tank. During the immobilization period, the fresh broth was replaced until the bacterial count reached nearly 10^8 - 10^9 CFU (g GAC^{-1}).

[0035] The bacterium-immobilized GAC was packed into a column (diameter 5.5 cm and height 40 cm) of a lab-scaled biofilter (similar to the one shown in FIG. 1). In the column, the packed volume and weight of GAC were 0.5 L and 0.24 kg, respectively.

[0036] Subsequently, H_2S gas (10000 ppm) supplied from a gas cylinder was diluted to 3000 ppm H_2S with compressed air and pumped upward through the column at the bottom. The results of the biofilter showed that the bacterium had remarkable removal efficiency of H_2S . In other words, the bacterium was an acidophilic sulfide-oxidizing bacterium and able to oxidize H_2S into sulfate, i.e., reducing H_2S concentration. Accordingly, the bacterium was identified as the following.

[0037] First, the genomic DNA was extracted and purified by a DNA kit (Geneaid Biotech Ltd.). A primer set specific for bacteria was provided, in which forward primer 9F was GAGTTTGATCCTGGCTCAG (SEQ ID No. 1), and reverse primer 1543R was AGAAAGGAGGTGATCCAGC (SEQ ID No. 2). Using the primer set, 16S rDNA of the bacterium was amplified by polymerase chain reaction (PCR) and analyzed by DNA sequencing. The sequence of 16S rDNA of the bacterium is shown as the following.

[SEQ ID No. 3]

TGCTAGATGCAGTCGAGCGGTGCATGTTTATACCTGTTCA

GCGCGGACGGGTGAGTAACGCGTGGGTGACCTACCCGGAAG

AGGCGGACAACCTGGGGAACCCAGGCTAATCCGCCATGTGG

-continued

TCCTGTCTGTGGGGCAGGACTAAAGGGTGGATAGCCCGCTTC
 CGGATGGGCCCCGCTCCATCAGCTAGTTGGTGGGGTAAAGGC
 CCACCAAGGCGACGACGGGTAGCCGGTCTGAGAGGATGGCCG
 GCCACAGGGGCACTGAGACACGGGCCCACTCTACGGGAGG
 CAGCAGTTACGAATCTTCCGAATGGACGGAAGTCTGACGGAG
 CGACCCCGCTTGGAGGAGGAAGCCCTTCGGGGTGTAACTCCT
 GAACTGGGGACGAAAGCCCTGTGTAGGGGATGACGGTACCC
 AGGTAATAGCGCCGGCCAACCTCCGTGCCAGCAGCCGGTAAT
 ACGGAGGGCGGAGCGTTACCCGGATTACTGGGCGTAAAGG
 GCGTGTAGCGGCCCTGGGGCGTCCCATGTGAAAGGCCACGGCT
 CAACCGTGGAGGAGCGTGGGATACGCTCAGGCTAGAGGGTGG
 GAGAGGGTGGTGAATTCCTGGAGTAGCGGTGAATGCGCAG
 ATACCGGGAGGAACGCCGATGGCGAAGGAGCCACCTGGTCC
 ACTTCTGACGCTGAGGCGCAAAGCGTGGGGAGCAAACCGGA
 TTAGATACCCGGTAGTCCACGCCCTAAACGATGCGCGCTAGG
 TCTTTGGGTTTATCTGGGGCCGAAGCCAACGCGTTAAGCGC
 GCCGCTGGGGAGTACGGCCCAAGGCTGAAACTCAAAGGAA
 TTGACGGGGCCCGCACAGCGGTGGAGCATGTGGTTAATTC
 GAAGCAACGCAAGAACCTTACAGGCTTGACATGCTGGGG
 AACCTAGGTGAAAGCCTGGGGTGCCTGCGAGGGAGCCCGAGC
 ACAGGTGCTGCATGGCCGTCGTCAGCTCGTGTCTGAGATGTT
 GGGTTAAGTCCCGCAACGAGCGCAACCCCTGCCCTTAGTTGCC
 AGCGGTTGGGCGGGCACTTAAGGGGACTGCCTGCGAAAG
 CAGGAGGAAGGCGGGACGAGCTGTGTCATCATGGCCCTTAC
 GGCTGGGCGACACAGTGTACAAATGCCCACTACAGAGCGA
 GGCGACCCAGTGATGGGAGCGAATCGCAAAAAGGTGGGCGT
 AGTTCGGATTGGGGTCTGCAACCCGACCCCATGAAGCCGGAAT
 CGCTAGTAATCGCGGATCAGCCATGCCCGGTGAATACGTTCC
 CGGGCCTGTACACACCCCGCTCAGCCATGGGAGCGGGTTC
 TACCCGAAGTCCGGGGAGCCTTAGGGCAGGCGCGAGGGTA
 GGGCTCGTGACT

[0038] Then, the above sequence was aligned and compared with available standard sequences of bacterial lineage in the National Center for Biotechnology Information (NCBI) GenBank using Basic Local Alignment Search Tool (BLAST). The phylogenetic tree was constructed using the neighbor-joining method (Saitou & Nei, 1987) via the MEGA 3.1 software with 1000 bootstrap replicates.

[0039] The results showed that the sulfide-oxidizing bacterium of the present example was classified in *Thermus* sp. In the present invention, the bacterium is named as *Thermus* sp. CP1.

Example 2

Oxidative Activity of Sulfide-Oxidizing Bacterium *Thermus* sp. CP1 to H₂S Removal Efficiency of H₂S for Continuous Operation

[0040] First, with reference to FIG. 1, a schematic diagram of a field biofilter used in the present example is shown. In the field biofilter, elimination of H₂S in biogas emitted from an anaerobic swine wastewater treatment system was measured.

[0041] As shown in FIG. 1, the biogas emitted from the swine wastewater treatment system 3 was introduced into an air-mixing bottle 8 by an exhaust fan 1. A flow meter 2 was connected therebetween to adjust the amount of biogas. An air compressor was used to compress air and was connected with another exhaust fan 1 and flow meter 2.

[0042] In addition, as described in the example mentioned above, the bacterium-immobilized GAC was packed into a column 5 (diameter 12 cm and height 65 cm) of the field biofilter. In the column, the packed volume and weight of GAC were 5 L and 2.4 kg, respectively. The bottom of the column 5 had an outlet 53 connected to a nutrient bottle 4. The culture medium of the nutrient bottle 4 was introduced through the column 5 from an inlet 54 by a peristaltic pump 6 and adjusted to a flow rate of 1 L/min by a regulator 7. The culture medium was supplied for 30 min per day. The air inlet 51 at the bottom of the column 5 was connected to the air-mixing bottle 8. The biogas of the air-mixing bottle 8 was charged from the air inlet 51 upward through the column 5 and discharged from an air outlet 52. During the gas supply, the flow rate of biogas was controlled at 150 L/hr.

[0043] The field biofilter was operated for eight hours per day. In order to estimate the operating performance of the biofilter for H₂S removal efficiency, the gas was supplied at the empty bed gas residence times (EBRTs) of 60 and 120 s. The EBRT was defined as the volume of the packed bed divided by the gas flow rate. During the operation of the field biofilter, H₂S gas concentrations at the inlet and the outlet of the column were determined by gas detector tubes (Kitagawa) ranging between 0.05% and 2% (detectable minimum concentration: 100 ppm) and between 0.01% and 0.2% (detectable minimum concentration: 50 ppm).

[0044] The H₂S removal rate in the bacterium-immobilized biofilter was calculated using the following equation derived from the following Michaelis-Menten equation (Hirai et al., 1990).

$$1/R = K_s/V_m * 1/C_{in} + 1/V_m$$

[0045] In the equation, R (g m⁻³ h⁻¹) is removal rate, C_{in} (g m⁻³) is the logarithmic mean concentration of H₂S at the inlet and outlet of the biofilter, V_m (g m⁻³ h⁻¹) is the maximum removal rate, and K, (g m⁻³) is the saturation constant.

[0046] For bacterial number estimation, 0.5 g GAC was taken out from the sample port and mixed with 5 mL sterile water. The sample was vortexed for 3 min, and the bacterial numbers on the support material of the biofilter system were determined after dilution by the plating count technique. Sulfate concentration in the biofilter was analyzed by a spectro-

photometer according to the Sulfate Reagent, SulfaVer® 4 (Hach). The results of the above experiments are shown in FIGS. 2 to 6.

[0047] FIG. 2 shows the influence of factors such as EBRT, shutdown timing, and H₂S concentration in the biogas to the H₂S removal efficiency during the continuous operation of the field biofilter. In FIG. 2, the dot mark denotes removal efficiency of H₂S, the triangle mark denotes H₂S concentration at the inlet of the field biofilter, and the square mark denotes H₂S concentration at the outlet of the field biofilter. Based on FIG. 2, when the flow rate of the biogas is 150 L/hr and the EBRT is 2 minutes, the average H₂S removal efficiency can reach approximately 95%.

[0048] FIG. 3 shows the relationship between the inlet loading and the elimination capacity of H₂S. With reference to FIG. 3, when the inlet loading of H₂S is about 400 g m⁻³ hr⁻¹, the maximum H₂S elimination capacity reaches approximately 352 g m⁻³ hr⁻¹. Furthermore, FIG. 4 shows the changes among pH value, cell number and sulfate concentration during continuous operation of the field biofilter. In FIG. 4, the dot mark denotes sulfate concentration, the triangle mark denotes cell number, the rhombus mark denotes pH value, and the arrow mark means the time point of supplying fresh medium. Based on FIG. 4, when the pH value is lower than 1 and the sulfate concentration reaches 54 g L⁻¹, the number of the acidophilic sulfide-oxidizing bacterium of the present invention immobilized on the support material still reaches 10⁶-10⁷ CFU per gram of GAC.

[0049] Moreover, FIG. 5 shows the relationship between the temperature and the removal efficiency of H₂S if the EBRT is 2 minutes. As shown in FIG. 5, when the temperature rises to about 35° C., the acidophilic sulfide-oxidizing bacterium of the present invention is able to achieve 100% H₂S removal efficiency. In addition, after the analysis of the sulfur equilibrium, it was found that 50% of H₂S was transformed into ionic sulfate.

[0050] FIG. 6 shows a linear regression chart of 1/R vs. 1/C_{in} in kinetics analysis. In FIG. 6, the gas flow rate is controlled in 150 L/hr, biogas concentration ranges from 1,500 to 5,000 ppm, and EBRT is 2 minutes. According to the slope and the intercept of the line shown in FIG. 6, the V_{in} and K_s values of the immobilized acidophilic sulfide-oxidizing bacterium of the present invention are 434.8 g m⁻³ hr⁻¹ and 3.3 g m⁻³, respectively. The K_s value of the acidophilic sulfide-oxidizing bacterium (*Thermus* sp. CP1) of the present invention is significantly lower than the K_s value (5.2 g m⁻³) of a known microbe, *Alcaligenes faecalis*, (Rattanapan et al., 2010). This result demonstrates that the acidophilic sulfide-oxidizing bacterium of the present invention has better affinity to H₂S. Besides, when *A. faecalis* is used to process H₂S, the main product (i.e., S) precipitates in the reaction. If *A. faecalis* is applied in the system for removing H₂S, S precipitate possibly incurs problems such as obstruction and short circuiting of the system. By contrast, the acidophilic sulfide-oxidizing bacterium (*Thermus* sp. CP1) of the present invention transforms H₂S into sulfate and thus the above-mentioned problems can be avoided.

[0051] Although the research (Duan, H. Q. et al., 2006) has shown that endobacteria of activated sludge immobilized on activated carbon can be used for H₂S removal, the elimination capacity and the removal efficiency only reaches 181 g m⁻³ h⁻¹ and 94%, respectively, and the H₂S concentration (about 87 ppm) of supplied gas is far lower than that of the field biogas. By contrast, in the experiments mentioned above, the

acidophilic sulfide-oxidizing bacterium (*Thermus* sp. CP1) of the present invention can remove the high H₂S concentration of the field biogas. When the inlet loading of H₂S is 400 g m⁻³ hr⁻¹, the composite of the present invention can achieve the maximum for H₂S removal, about 352 g m⁻³ hr⁻¹, far higher than that of the conventional research.

Example 3

H₂S Removal Efficiency of Known *Thermus* sp

[0052] As the method described in Example 1, *Thermus scotoeductus* (ATCC 51532, purchased from BCRC in Hsinchu, Taiwan) was immobilized on GAU and packed into a column 5 (diameter 5.4 cm and height 35 cm) of the field biofilter as shown in FIG. 7. In the column, the packed volume of GAC was 500 mL. H₂S gas (10000 ppm) supplied from a gas cylinder 9 pumped into an air-mixing bottle 8 by an exhaust fan 1. A flow meter 2 was connected therebetween to adjust the amount of H₂S. An air compressor was used to compress air and connected with another exhaust fan 1 and flow meter 2.

[0053] The air was supplied into the air-mixing bottle 8 to dilute H₂S to 5.6 g/m³ (4,000 ppm). The gas mixture was charged from an air inlet 51 at the bottom of the column 5 upward through the column 5 and then discharged from an air outlet 52 at the top of the column 5. During the reaction, an outlet 53 at the bottom of the column 5 was connected to a nutrient bottle 4. The culture medium of the nutrient bottle 4 was introduced through the column 5 from an inlet 54 by a peristaltic pump 6 and adjusted in a stable flow rate by a regulator 7. After long-term operation of 28 days, H₂S gas concentrations were determined by gas detector tubes (Kitagawa) with different detectable concentration ranges during the operation of the field biofilter. The result is shown in FIG. 8.

[0054] FIG. 8 shows the changes of H₂S concentration and removal efficiency. In FIG. 8, the dot mark denotes removal efficiency of H₂S, the triangle mark denotes H₂S concentration at the inlet of the field biofilter, and the square mark denotes H₂S concentration at the outlet of the field biofilter. According to FIG. 8, it can be seen that *Thermus scotoeductus* is able to maintain H₂S removal efficiency about 90% or more when the gas retention time is 2 minutes. In the condition of flow loading 167 g m⁻³ h⁻¹, the maximum loading removal rate is 159 g m⁻³ h⁻¹. This result indicates that *Thermus scotoeductus* has good performance for H₂S-removal.

[0055] In conclusion, the biological composite and the method for reducing H₂S and the acidophilic sulfide-oxidizing bacterium of the present invention can stably reduce H₂S in processes such as petrochemical oil-refining, production of biogas and natural gas, and papermaking (i.e., H₂SO₄ is easily accumulated with the proceeding processes). Even if H₂SO₄ is accumulated along with the increase in reaction time to reduce the environmental pH value, the biological composite and the method for reducing H₂S and the acidophilic sulfide-oxidizing bacterium of the present invention are still able to maintain H₂S removal efficiency. Therefore, H₂S erosion to machines or lethal effects on humans can be avoided.

[0056] Although the present invention has been explained in relation to its preferred embodiment, it is to be understood that many other possible modifications and variations can be made without departing from the spirit and scope of the invention as hereinafter claimed.

SEQUENCE LISTING

<160> NUMBER OF SEQ ID NOS: 3

<210> SEQ ID NO 1
<211> LENGTH: 19
<212> TYPE: DNA
<213> ORGANISM: Artificial
<220> FEATURE:
<223> OTHER INFORMATION: Forward primer

<400> SEQUENCE: 1

gagtttgatc ctggctcag 19

<210> SEQ ID NO 2
<211> LENGTH: 19
<212> TYPE: DNA
<213> ORGANISM: Artificial
<220> FEATURE:
<223> OTHER INFORMATION: Reverse primer

<400> SEQUENCE: 2

agaaaggagg tgatccagc 19

<210> SEQ ID NO 3
<211> LENGTH: 1411
<212> TYPE: DNA
<213> ORGANISM: *Thermus sp.*

<400> SEQUENCE: 3

tgctagatgc agtcgagcgg tgcactgtta tacctgttca gcggcggacg ggtgagtaac 60
gcgtgggtga cctacccgga agagggcgac aacctgggga aaccaggct aatccgccat 120
gtggtcctgt cctgtggggc aggactaaag ggtggatagc ccgcttcgg atgggcccgc 180
gtcccatcag ctagtgtgtg gggtaaaggc ccaccaaggc gacgacgggt agccggtctg 240
agaggatggc cgccacaggg ggcactgaga cacgggcccc actcctacgg gaggcagcag 300
ttacgaatct tccgaatgg acggaagtct gacggagcga ccccgcttg aggaggaagc 360
ccttcggggt gtaaaactct gaactgggga cgaagccct gtgtaggggg atgacggtac 420
ccaggtaata gcgcccggca actccgtgcc agcagccgcg gtaatacga gggcgcgagc 480
gttaccggga tttactgggc gtaaaggggc tgtaggcggc ctggggcgtc ccatgtgaaa 540
ggccacggct caacctgga ggagcgtggg atacgctcag gctagagggt gggagagggt 600
ggtggaattc ccggagtagc ggtgaaatgc gcagataccg ggaggaacgc cgatggcgaa 660
ggcagccacc tggctccact ctgacgctga ggcgcgaaag cgtggggagc aaaccggatt 720
agataccggg gtagtccacg ccctaaacga tgcgcgctag gtctttgggg tttatctggg 780
ggccgaagcc aacgcgttaa gcgcccggcc tggggagtac ggccgcaagg ctgaaactca 840
aaggaattga cggggggccc cacaagcggg ggagcatgtg gtttaattcg aagcaacgcg 900
aagaacctta ccaggccttg acatgctggg gaacctaggt gaaagcctgg ggtgcccgcg 960
agggagcccc agcacagggt ctgcatggcc gtcgctcagc cgtgctgta gatggtgggt 1020
taagtccgcg aacgagcgca acccctgccc ttagttgcca gcgggttggg ccgggcactc 1080
taaggggact gcctgcgaaa gcaggaggaa ggcggggagc acgtctggtc atcatggccc 1140
ttacggcctg ggcgacacac gtgctacaat gccactaca gacgagggcg acccagtgat 1200
ggggagcgaa tcgcaaaaag gtgggcgtag ttcggattgg ggtctgcaac cggacccat 1260

-continued

gaagccggaa tcgctagtaa tcgcggatca gccatgccgc ggtgaatcgc tteccgggcc	1320
ttgtacacac cgcccgtcac gccatgggag cgggttctac ccgaagtgcg cgggagcctt	1380
agggcaggcg ccgagggtag ggctcgtgac t	1411

1. A biological composite for reducing H₂S, comprising: a carrier; and
Thermus sp. bacterium immobilized on the carrier.
2. The biological composite of claim 1, wherein the carrier is at least one selected from a group consisting of activated carbon, peat soil, compost, bark, vermiculite, oyster shell, zeolite, porphyritic andesite, iron hydroxide, active alumina, pearlite, snake-wood, and artificially synthesized chemical materials.
3. The biological composite of claim 2, wherein the *Thermus* sp. bacterium forms a biofilm encompassing the carrier.
4. The biological composite of claim 3, wherein the 16S rDNA sequence of the *Thermus* sp. bacterium is SEQ ID NO. 3.
5. The biological composite of claim 1, wherein the *Thermus* sp. bacterium is deposited as BCRC 910527 in Bioresource Collection and Research Center in Hsinchu, Taiwan.
6. The biological composite of claim 1, wherein the *Thermus* sp. bacterium is *Thermus scotoeductus*.
7. A biological method for reducing H₂S, comprising the following step:
making *Thermus* sp. bacterium in contact with a sample containing H₂S.
8. The method of claim 7, wherein the *Thermus* sp. bacterium is immobilized on a carrier.
9. The method of claim 8, wherein the carrier is at least one selected from a group consisting of activated carbon, peat soil, compost, bark, vermiculite, oyster shell, zeolite, porphyritic andesite, iron hydroxide, active alumina, pearlite, snake-wood, and artificially synthesized chemical materials.
10. The method of claim 9, wherein the *Thermus* sp. bacterium forms a biofilm encompassing the carrier.
11. The method of claim 10, wherein the 16S rDNA sequence of the *Thermus* sp. bacterium is SEQ ID NO. 3.
12. The method of claim 7, wherein the *Thermus* sp. bacterium is deposited BCRC 910527 in Bioresource Collection and Research Center in Hsinchu, Taiwan.
13. The method of claim 7, wherein the *Thermus* sp. bacterium is *Thermus scotoeductus*.
14. An acidophilic sulfide-oxidizing bacterium, which is *Thermus* sp. bacterium and of which 16S rDNA sequence comprises SEQ ID NO. 3.
15. The acidophilic sulfide-oxidizing bacterium of claim 14, which is deposited BCRC 910527 in Bioresource Collection and Research Center in Hsinchu, Taiwan.

* * * * *