



(19) **United States**

(12) **Patent Application Publication**  
**TSAI**

(10) **Pub. No.: US 2013/0037971 A1**

(43) **Pub. Date: Feb. 14, 2013**

(54) **WETTED WALL VENTURI SCRUBBER WITH  
A 2-STAGE VENTURI THROAT**

**Publication Classification**

(71) Applicant: **NATIONAL CHIAO TUNG  
UNIVERSITY**, Hsinchu City (TW)

(51) **Int. Cl.**  
**B01D 47/10** (2006.01)

(52) **U.S. Cl.** ..... **261/72.1**

(72) Inventor: **Chuen-Jinn TSAI**, Zhubei City (TW)

(57) **ABSTRACT**

(73) Assignee: **NATIONAL CHIAO TUNG  
UNIVERSITY**, Hsinchu City (TW)

A venturi scrubber, which avoids clogging in the throat by dust particles, includes a venturi tube, two scrubbing fluid conduits and a scrubbing fluid tank. The venturi tube has a converging section, a diverging section and a throat section which is connected between the converging section and the diverging section. The scrubbing fluid conduit has a top end connected with the bottom end of the converging section of the venturi tube, and the scrubbing fluid conduit is connected with the scrubbing fluid tank. Thereby, scrubbing fluid can be guided directly into the scrubbing fluid tank without passing through the throat section. As a result, the clogging of dust particles on the converging section of the venturi throat can be minimized and the abnormal increase of the pressure drop of the throat can also be avoided.

(21) Appl. No.: **13/653,983**

(22) Filed: **Oct. 17, 2012**

**Related U.S. Application Data**

(62) Division of application No. 12/662,899, filed on May 11, 2010.

**Foreign Application Priority Data**

(30) Sep. 7, 2009 (TW) ..... 98130125

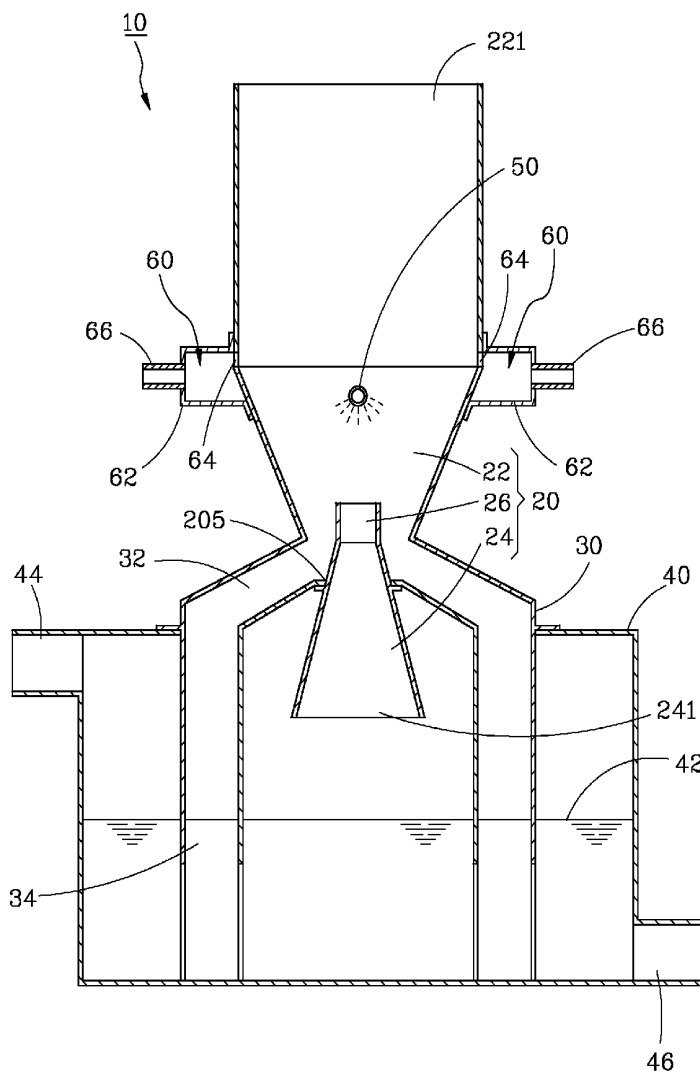

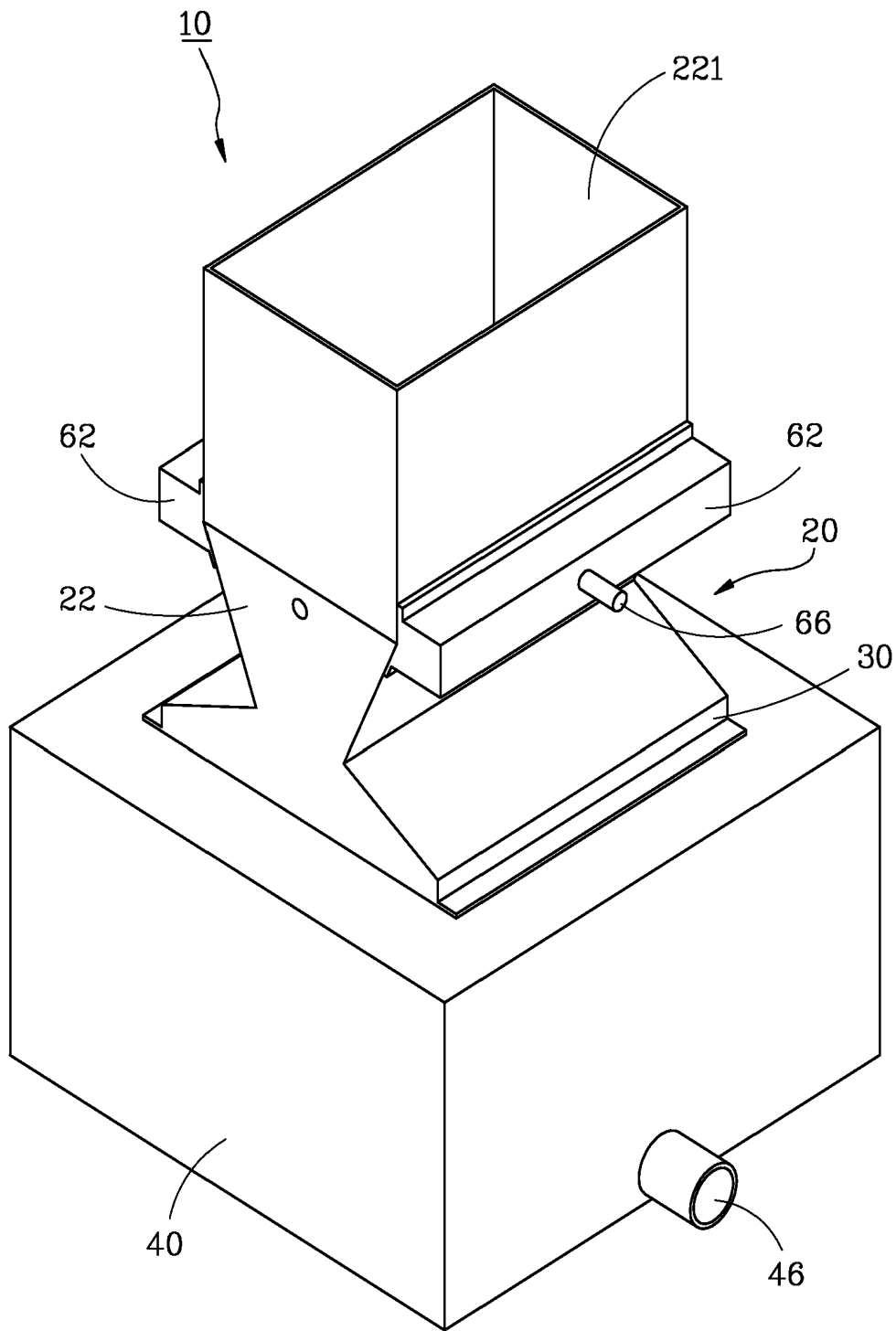

FIG. 1

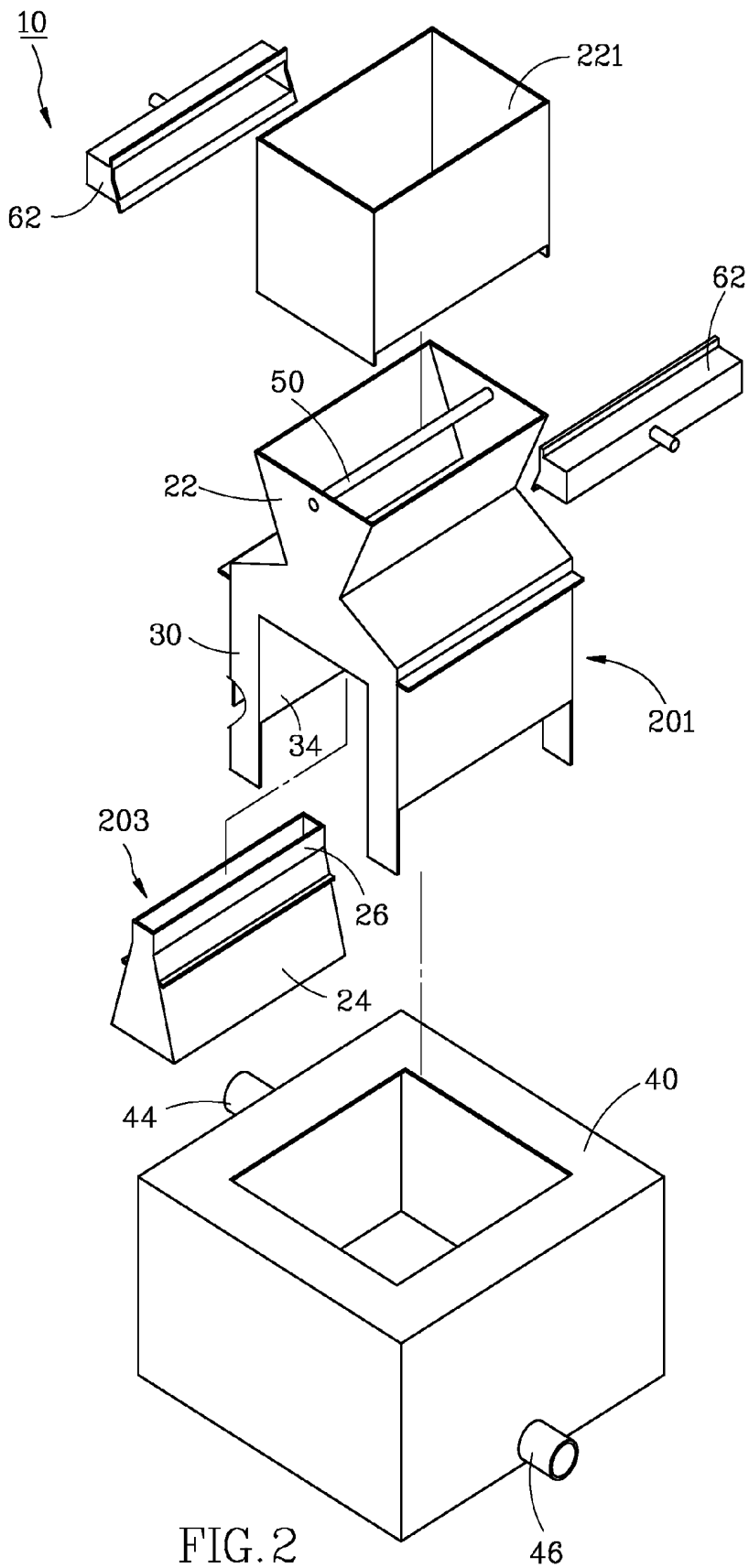

FIG. 2

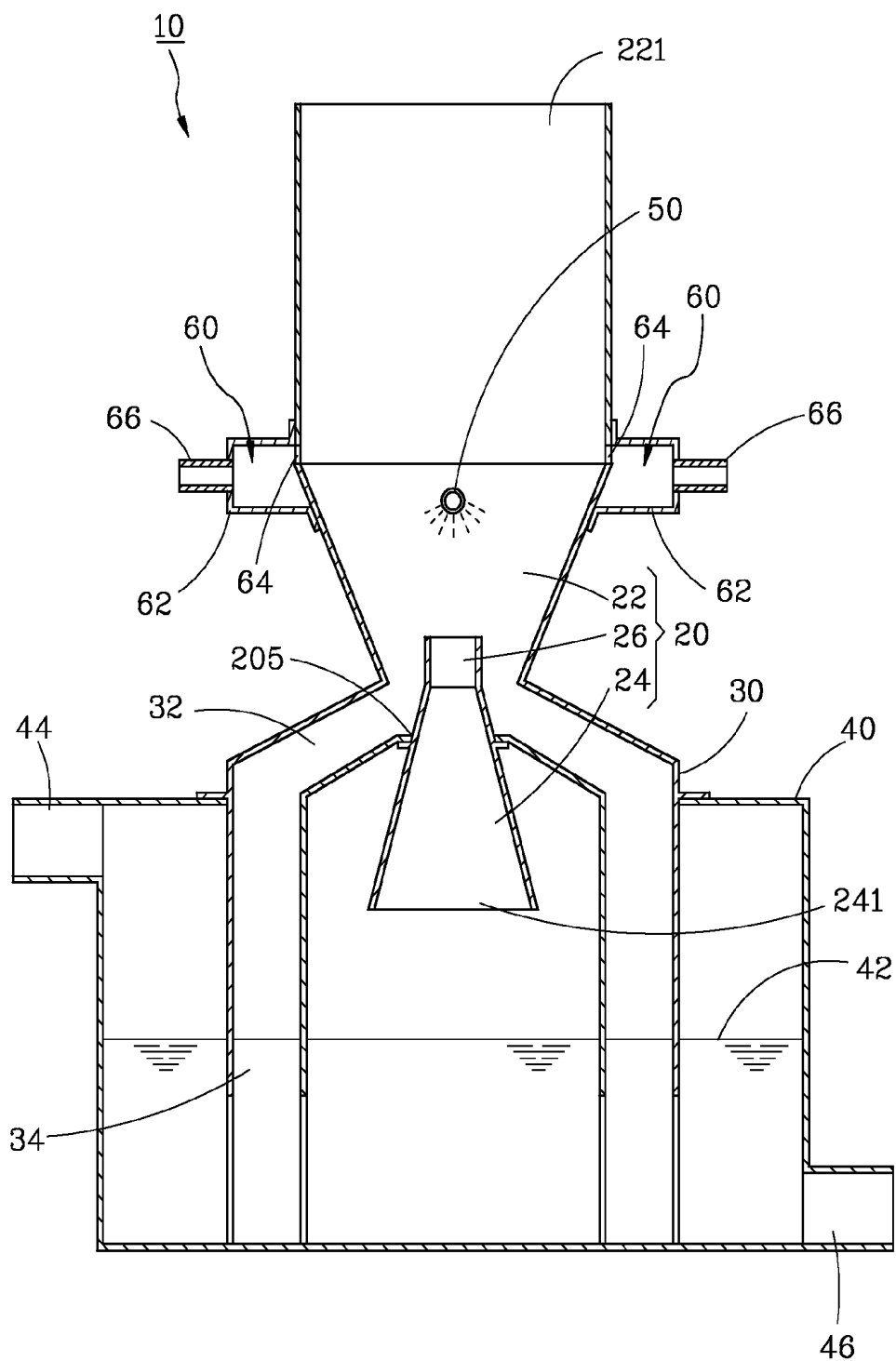

FIG. 3

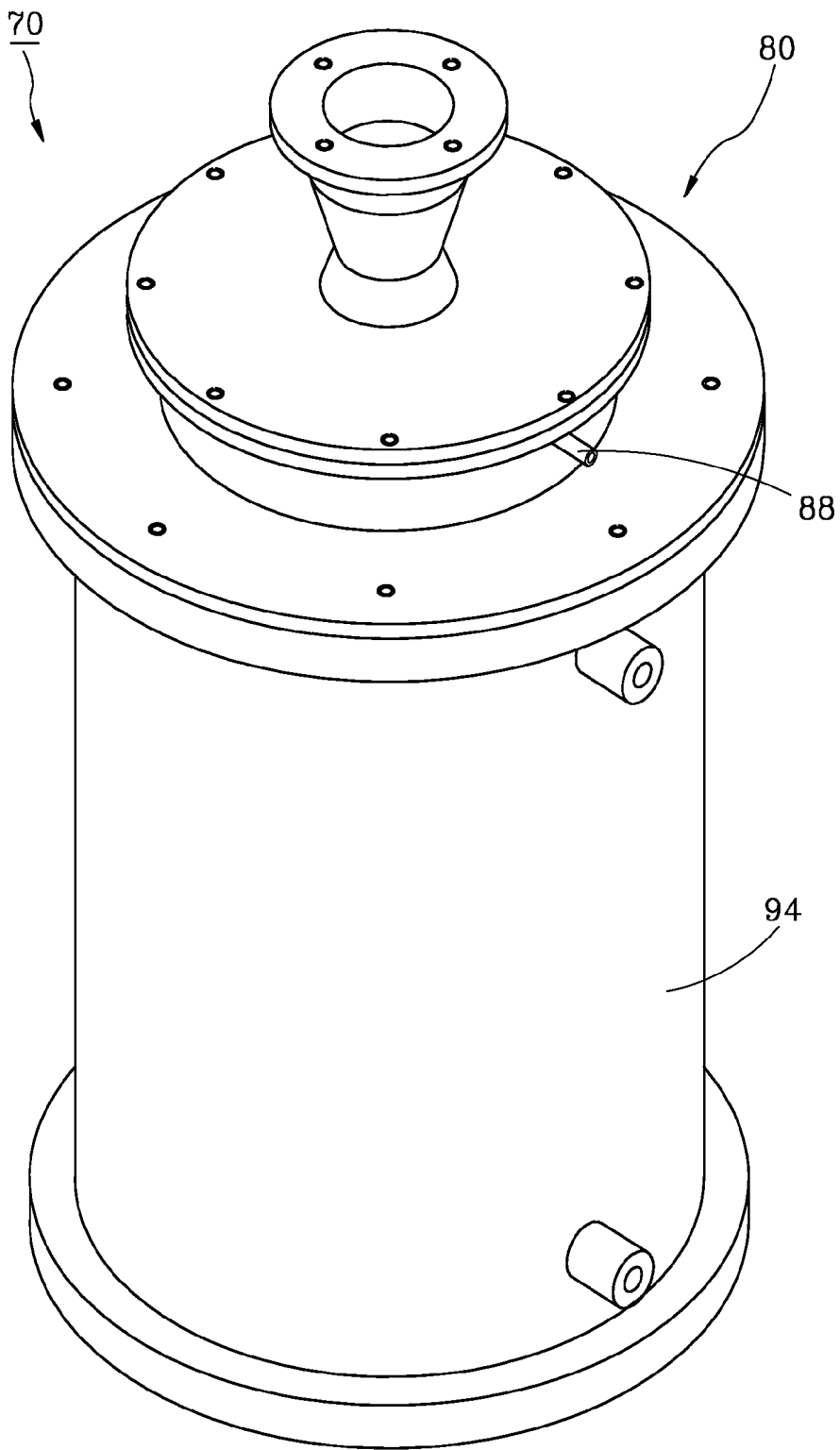

FIG. 4

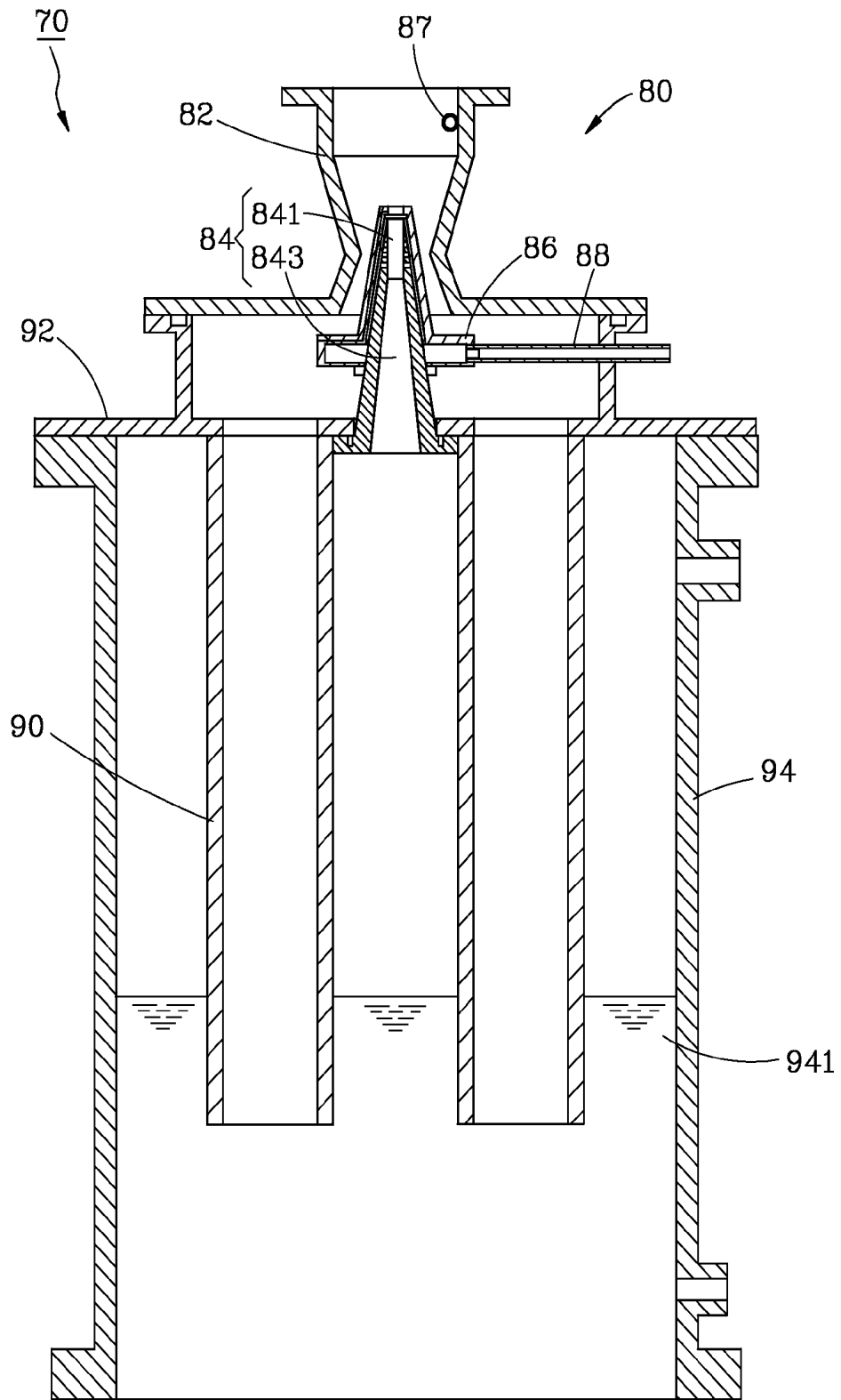

FIG. 5

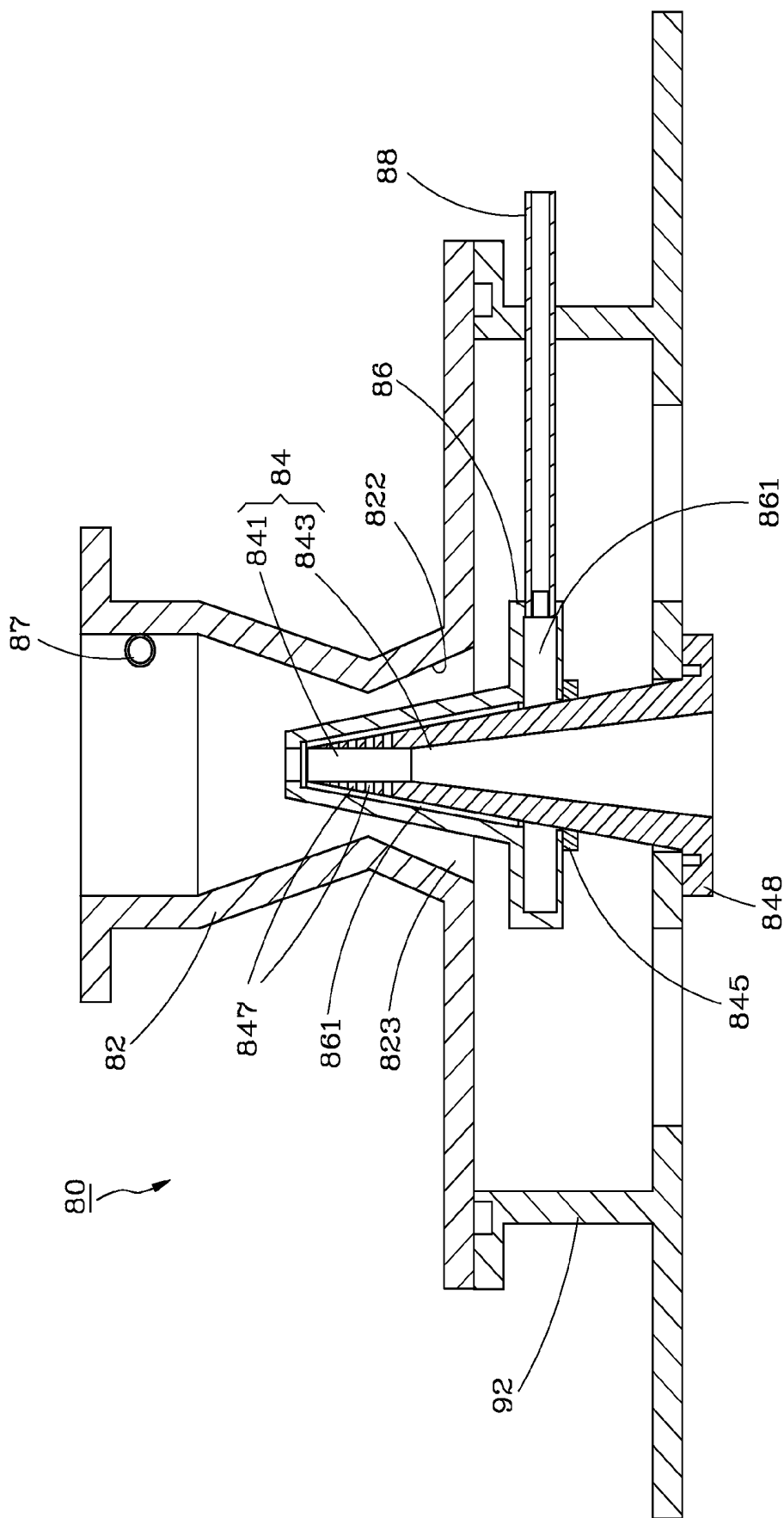

FIG. 6

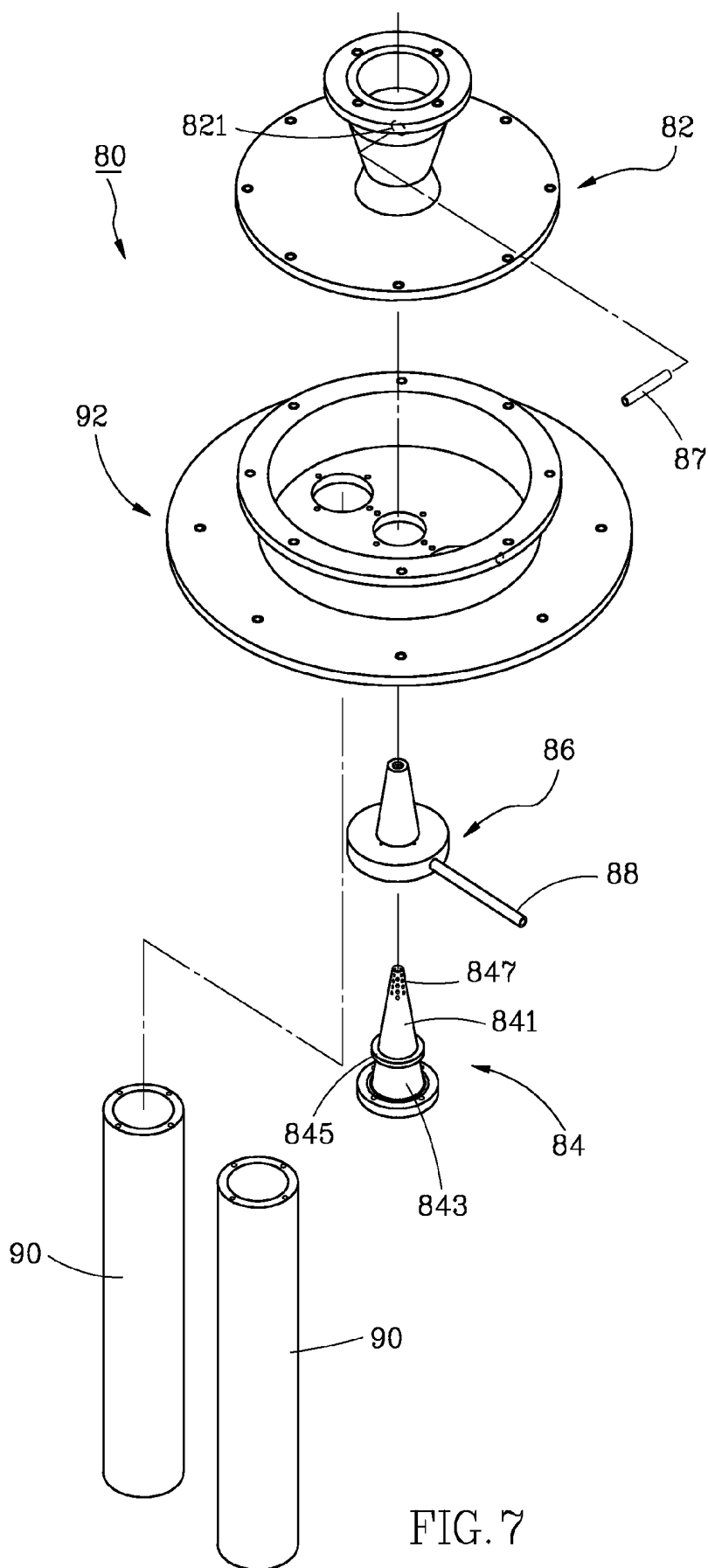

FIG. 7



## WETTED WALL VENTURI SCRUBBER WITH A 2-STAGE VENTURI THROAT

### CROSS-REFERENCE TO RELATED APPLICATION

**[0001]** This patent application is a division of U.S. patent application Ser. No. 12/662,899 filed May 11, 2010 entitled "Wetted Wall Venturi Scrubber with A 2-Stage Venturi Throat", the entire disclosure of which is incorporated herein by reference.

### BACKGROUND OF THE INVENTION

**[0002]** 1. Field of the Invention

**[0003]** The present invention relates to air pollution control equipment and more particularly, to a wetted wall venturi scrubber with a 2-stage venturi throat, which avoids clogging in the throat by dust particles.

**[0004]** 2. Description of the Related Art

**[0005]** For the advantage of excellent particle removal efficiency, venturi scrubber has been intensively used in the industry. A regular venturi scrubber, as disclosed in 2005 in J. Air & Waste Manage. Assoc. by Tsai et al, generally comprises a converging section, a diverging section and a throat. The throat is formed between the converging section and the diverging section. During application, waste gas to be treated with scrubbing fluid droplets are guided into the converging section and, as the area decreases, gas velocity increases. The inlet gas shears the scrubbing fluid droplets subject to a velocity difference between the inlet gas and the scrubbing fluid droplets. Particle and gas removal occur in the throat section as the inlet gas stream mixes with the scrubbing fluid droplets.

**[0006]** When waste gas having a high particle concentration is introduced into the venturi scrubber, the particles tend to be adhered to the inside wall of the converging section. Accumulation of particles in the converging section results in throat clogging, thereby causing operation instability and abnormal increase of pressure drop. Further, the aforesaid prior art venturi scrubber has a special shape, complicating the fabrication process.

### SUMMARY OF THE INVENTION

**[0007]** The present invention has been accomplished under the circumstances in view. It is the main object of the present invention to provide a wetted wall venturi scrubber with a 2-stage venturi throat, which avoids clogging in the throat by dust particles.

**[0008]** It is another object of the present invention to provide a wetted wall venturi scrubber with a 2-stage venturi throat, which reduces the manufacturing time, labor and cost.

**[0009]** To achieve these and other objects of the present invention, a wetted wall venturi scrubber with a 2-stage venturi throat comprises a venturi tube, a conduit and a storage tank. The venturi tube comprises a converging section, a diverging section and a throat connected between the converging section and the diverging section. The throat comprises a gas inlet. The diverging section comprises a gas outlet. The conduit has its top end connected with the bottom side of the converging section. The storage tank is connected with the bottom end of the conduit.

**[0010]** Further, the storage tank stores a scrubbing fluid. The bottom end of the conduit extends below the level of the scrubbing fluid in the storage tank. The wetted wall venturi scrubber further comprises an atomized sprayer mounted

inside the converging section of the venturi tube, an overflow gutter connected with the converging section of the venturi tube.

**[0011]** Further, the throat of the venturi tube has a boundary wall extended to the inside of the converging section.

**[0012]** Further, the venturi tube and the conduit can be formed of an outer tube and an inner tube. In this case, the converging section of the venturi tube and the conduit are formed in the outer tube; the throat and the diverging section of the venturi tube are formed in the inner tube; the outer tube comprises a through hole for the insertion of one end of the inner tube.

**[0013]** In one embodiment of the present invention, the venturi tube further comprises a bushing sleeved onto the inner tube and disposed inside the outer tube. Further, the bushing and the outer tube defining therebetween a scrubbing fluid inlet passage. The inner tube of the venturi tube comprises a plurality of jet nozzles disposed in communication with the inside of the inner tube and the scrubbing fluid inlet passage. Further, the inner tube of the venturi tube comprises a rib extending around the periphery thereof and abutted against the bottom side of the bushing. Further, the conduit is connected with the outer tube by a dock, and the inner tube is mounted on the dock. Further, the converging section has a tubular shape. The venturi tube comprises a wall-cleaning scrubbing fluid supply pipe connected with the top side of the converging section. The wall-cleaning scrubbing fluid supply pipe extends along the converging section in the tangential direction.

### BRIEF DESCRIPTION OF THE DRAWINGS

**[0014]** FIG. 1 is an elevational view of a wetted wall venturi scrubber with a 2-stage venturi throat in accordance with a first embodiment of the present invention.

**[0015]** FIG. 2 is an exploded view of the wetted wall venturi scrubber with a 2-stage venturi throat in accordance with the first embodiment of the present invention.

**[0016]** FIG. 3 is a sectional view of the wetted wall venturi scrubber with a 2-stage venturi throat in accordance with the first embodiment of the present invention.

**[0017]** FIG. 4 is an elevational view of a wetted wall venturi scrubber with a 2-stage venturi throat in accordance with a second embodiment of the present invention.

**[0018]** FIG. 5 is a sectional view of the wetted wall venturi scrubber with a 2-stage venturi throat in accordance with the second embodiment of the present invention.

**[0019]** FIG. 6 is a sectional view of the venturi tube of the wetted wall venturi scrubber with a 2-stage venturi throat in accordance with the second embodiment of the present invention.

**[0020]** FIG. 7 is an exploded view of the venturi tube and conduits of the venturi tube of the wetted wall venturi scrubber with a 2-stage venturi throat in accordance with the second embodiment of the present invention.

### DETAILED DESCRIPTION OF THE INVENTION

**[0021]** Referring to FIGS. 1-3, a wetted wall venturi scrubber with a 2-stage venturi throat 10 in accordance with a first embodiment of the present invention is shown comprising a venturi tube 20, two scrubbing fluid conduits 30, a scrubbing fluid tank 40, an atomized sprayer 50 and two overflow gutters 60.

[0022] The venturi tube 20 comprises a converging section 22, a diverging section 24 and a throat 26. The throat 26 is connected between the converging section 22 and the diverging section 24 with its boundary wall extended to the inside of the converging section 22. The converging section 22 has a gas inlet 221 formed in its one end remote from the throat 26. The diverging section 24 has a gas outlet 241 formed in its one end remote from the throat 26.

[0023] The two scrubbing fluid conduits 30 each have a top end 32 connected with the bottom side of the converging section 22 of the venturi tube 20, and a bottom end 34 connected with the scrubbing fluid tank 40.

[0024] During fabrication, connecting an outer tube 201 and an inner tube 203 forms the venturi tube 20 and the two scrubbing fluid conduits 30. The converging section 22 of the venturi tube 20 and the two scrubbing fluid conduits 30 are formed in the outer tube 201. The throat 26 and diverging section 24 of the venturi tube 20 are formed in the inner tube 203. The outer tube 201 has a through hole 205 for the passing of the top end of the inner tube 203.

[0025] The scrubbing fluid tank 40 is connected with the bottom side of the outer tube 201 to collect the scrubbing fluid. The two scrubbing fluid conduits 30 extend below the fluid level of the scrubbing fluid, avoiding passing of the waste gas through the two scrubbing fluid conduits 30 directly without scrubbing. The inside space of the scrubbing fluid tank 40 is kept in communication with the diverging section 24 of the venturi tube 20. The scrubbing fluid tank 40 has an exhaust hole 44 and a scrubbing fluid outlet 46 respectively disposed in the top and bottom sides.

[0026] The atomized sprayer 50 is mounted inside the converging section 22 of the venturi tube 20 to spray a fine mist of scrubbing fluid droplets.

[0027] The two overflow gutters 60 are formed by affixing two connectors 62 to the outside of the converging section 22, each having an opening 64 kept in communication with the inside of the converging section 22 of the venturi tube 20.

[0028] The venturi tube 10 is adapted to remove dust particles from the waste gas by means of the scrubbing fluid. The scrubbing fluid is introduced into the venturi tube 20 through the atomized sprayer 50. When the user draws air out of the scrubbing fluid tank 40 through the exhaust hole 44, the waste gas to be treated is guided through the gas inlet 221 into the converging section 22. Thereafter, the mist of fine mist of scrubbing fluid droplets generated by the atomized sprayer 50 is mixed with the waste gas to flow into the throat 26, thereby causing dust particles to be removed from the waste gas. The purified gas is drawn through the inside of the scrubbing fluid tank 40 and the exhaust hole 44 to the outside. After passing through the throat 26 and diverging section 24 of the venturi tube 20, the scrubbing fluid flows into the scrubbing fluid tank 40.

[0029] Further, the scrubbing fluid in the scrubbing fluid tank 40 is guided through a circulating piping (not shown) and two wall-cleaning scrubbing fluid supply pipes 66 to the two overflow gutters 60 where the scrubbing fluid flows over the gutters 60 into the converging section 22 of the venturi tube 20 to wet its inside wall, avoiding adhesion and accumulation of dust particles. The overflowing scrubbing fluid flows along the scrubbing fluid conduits 30 back to the scrubbing fluid tank 40.

[0030] When flowing along the inside wall of the converging section 22, the overflowing scrubbing fluid carries adhered dust particles away from the inside wall of the con-

verging section 22, avoiding clogging in the throat 26. Further, the scrubbing fluid for wetting the inside wall of the converging section 22 is directly guided back to the scrubbing fluid tank 40 by the scrubbing fluid conduits 30. Actually, only the fine mist of scrubbing fluid droplets generated by the atomized sprayer 50 is guided through the throat 26. Therefore, the invention avoids clogging in the throat 26 by dust particles due to passing of an over amount of the scrubbing fluid and abnormal pressure drop caused by clogging.

[0031] Further, as stated above, connecting an outer tube 201 with an inner tube 203 forms the venturi tube 20 and the scrubbing fluid conduits 30. So far as the configuration is concerned, the outer tube 201 and the inner tube 203 can be made much easier than a conventional venturi tube, saving much manufacturing time, labor and cost. Further, the boundary wall of the throat 26 of the venturi tube 20 extends to the inside of the converging section 22, facilitating flowing of the scrubbing fluid along the inside wall of the converging section 22 into the scrubbing fluid conduits 30.

[0032] Based on the spirit of the present invention, the structure of the venturi tube may be variously embodied. FIGS. 4-7 illustrate a wetted wall venturi scrubber with a 2-stage venturi throat 70 in accordance with a second embodiment of the present invention. Substantially similar to the aforesaid first embodiment, the wetted wall venturi scrubber with a 2-stage venturi throat 70 in accordance with this second embodiment comprises a venturi tube 80, two scrubbing fluid conduits 90 and a scrubbing fluid tank 94.

[0033] The venturi tube 80 is formed by connecting an outer tube 82, an inner tube 84, a bushing 86, a wall-cleaning scrubbing fluid supply pipe 87 and a dust particle scrubbing fluid supply pipe 88 with one another. The outer tube 82 is a cylindrical tube defining a converging section 82. Further, the outer tube 82 has a hole 821 near the top side of the converging section 82 for the insertion of the wall-cleaning scrubbing fluid supply pipe 87. The wall-cleaning scrubbing fluid supply pipe 87 extends along the tangential direction so that the scrubbing fluid slows spirally through the converging section 82. The outer tube 82 further has a through hole 822 on the bottom side for the insertion of the inner tube 84. The inner tube 84 defines a throat 841 and a diverging section 843. Further, the inner tube 84 has a rib 845 extending around the periphery. The throat 841 has a plurality of jet nozzles 847 on the top side. The bushing 86 is sleeved onto the inner tube 84 and disposed inside the outer tube 82, defining with the outer tube 82 a scrubbing fluid inlet passage 861 that communicates with the outside through the dust particle scrubbing fluid supply pipe 88 and the inside of the inner tube 84 through the jet nozzles 847. The bottom side of the bushing 86 is abutted against the rib 845 of the inner tube 84.

[0034] The two scrubbing fluid conduits 90 are connected to the outer tube 82 by a dock 92. The inner tube 84 is fixedly mounted on the dock 92.

[0035] The scrubbing fluid 941 is the scrubbing fluid tank 94 is guided through a circulation piping (not shown) and the wall-cleaning scrubbing fluid supply pipe 87 into the converging section 82 of the venturi tube 80 to wet the inside wall of the converging section 82. Thereafter, the scrubbing fluid flows through a scrubbing fluid outlet passage 823 between the outer tube 82 and the bushing 86 into the inside of the dock 92, and then through the scrubbing fluid conduits 90 into the scrubbing fluid tank 94. Further, the scrubbing fluid after purification is guided through the dust particle scrubbing fluid

supply pipe **88**, the scrubbing fluid inlet passage **861** and the jet nozzles **847** into the throat **841** to remove dust particles from the waste gas.

**[0036]** Although particular embodiments of the invention have been described in detail for purposes of illustration, various modifications and enhancements may be made without departing from the spirit and scope of the invention. Accordingly, the invention is not to be limited except as by the appended claims.

What is claimed is:

1. A wetted wall venturi scrubber, comprising:

a venturi tube, said venturi tube comprising a converging section, a diverging section and a throat connected between said converging section and said diverging section, said throat comprising a gas inlet, said diverging section comprising a gas outlet;

a conduit, said conduit having a top end connected with a bottom side of said converging section and a bottom end; and

a storage tank connected with the bottom end of said conduit;

wherein said storage tank stores a scrubbing fluid; the bottom end of said conduit extends below the level of said scrubbing fluid in said storage tank.

2. The wetted wall venturi scrubber as claimed in claim 1, further comprising an atomized sprayer mounted inside said converging section of said venturi tube.

3. The wetted wall venturi scrubber as claimed in claim 1, further comprising an overflow gutter connected with said converging section of said venturi tube.

4. The wetted wall venturi scrubber as claimed in claim 1, wherein said throat of said venturi tube has a boundary wall extended to the inside of said converging section.

5. The wetted wall venturi scrubber as claimed in claim 1, wherein said venturi tube and said conduit are formed of an outer tube and an inner tube; said converging section of said venturi tube and said conduit are formed in said outer tube; said throat and said diverging section of said venturi tube are formed in said inner tube; said outer tube comprises a through hole for the insertion of one end of said inner tube.

\* \* \* \* \*