



(19) **United States**

(12) **Patent Application Publication**
Ker et al.

(10) **Pub. No.: US 2012/0290046 A1**
(43) **Pub. Date: Nov. 15, 2012**

(54) **LOAD-ADAPTIVE BIOELECTRIC CURRENT STIMULATOR**

(52) **U.S. Cl. 607/62**

(76) **Inventors:** **Ming-Dou Ker**, Hsinchu County (TW); **Wei-Ling Chen**, Taipei City (TW); **Chun-Yu Lin**, Hualien County (TW)

(57) **ABSTRACT**

The disclosure relates to a load-adaptive bioelectrical current stimulator, which comprises a current output module, an adaptation module and a control module. The current output module generates a stimulus current to an electrode. The adaptation module detects the electrical status of the stimulus current passing through the electrode and generates a feedback signal to the control module. According to the feedback signal, the control module controls the current output module to stabilize the output status of the stimulus current adaptively. Thereby, the load-adaptive bioelectrical current stimulator can use the feedback control mechanism to regulate the value of the stimulus current to adapt to variation of load impedance.

(21) **Appl. No.: 13/224,166**

(22) **Filed: Sep. 1, 2011**

(30) **Foreign Application Priority Data**

May 13, 2011 (TW) 100116827

Publication Classification

(51) **Int. Cl.**
A61N 1/36 (2006.01)

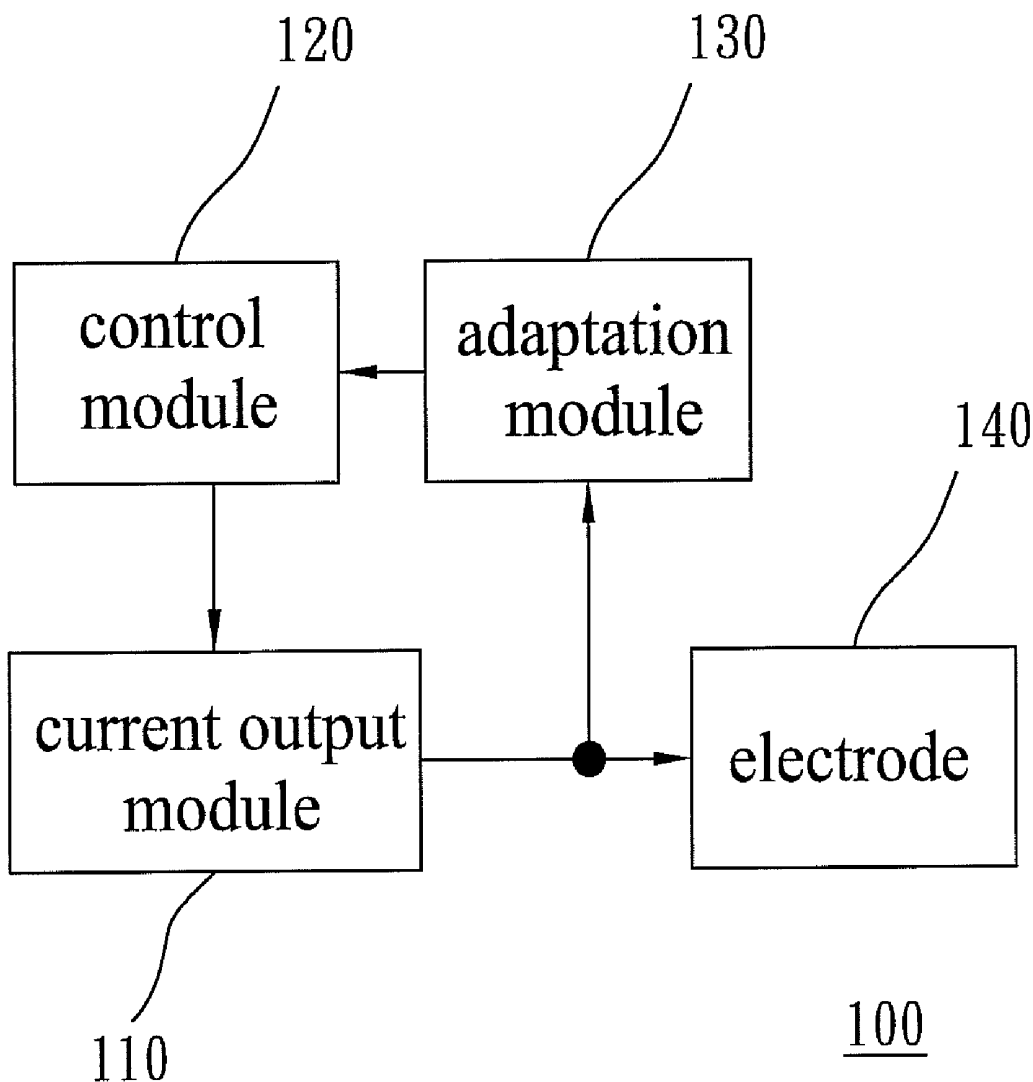

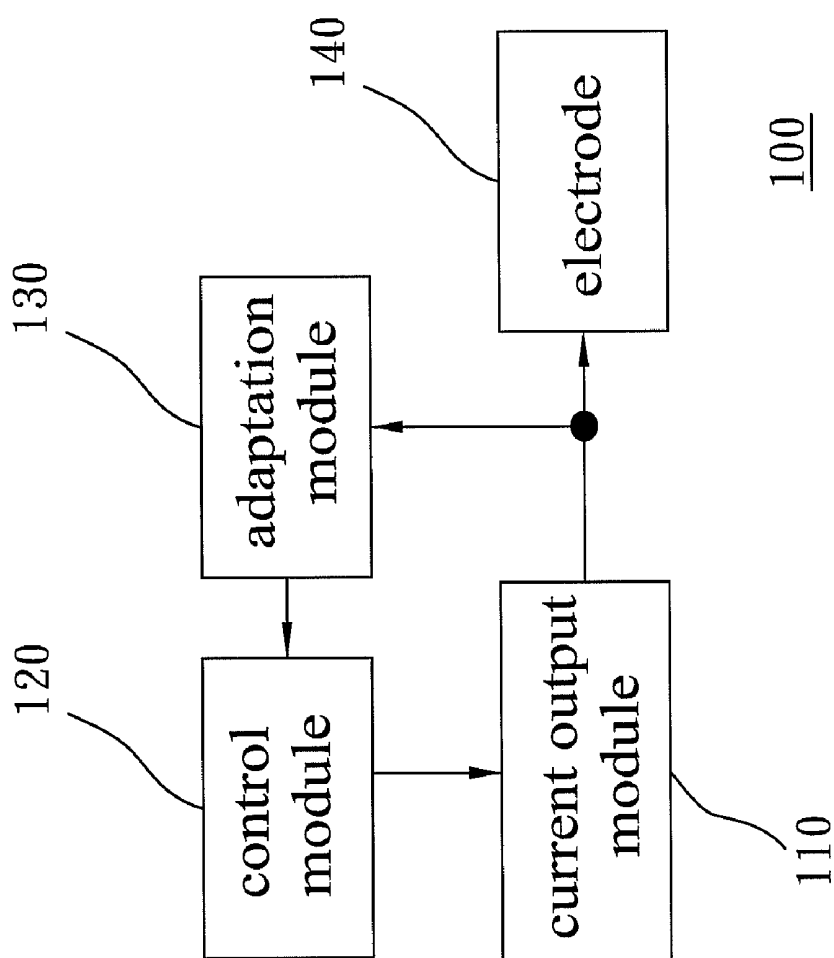

Fig. 1

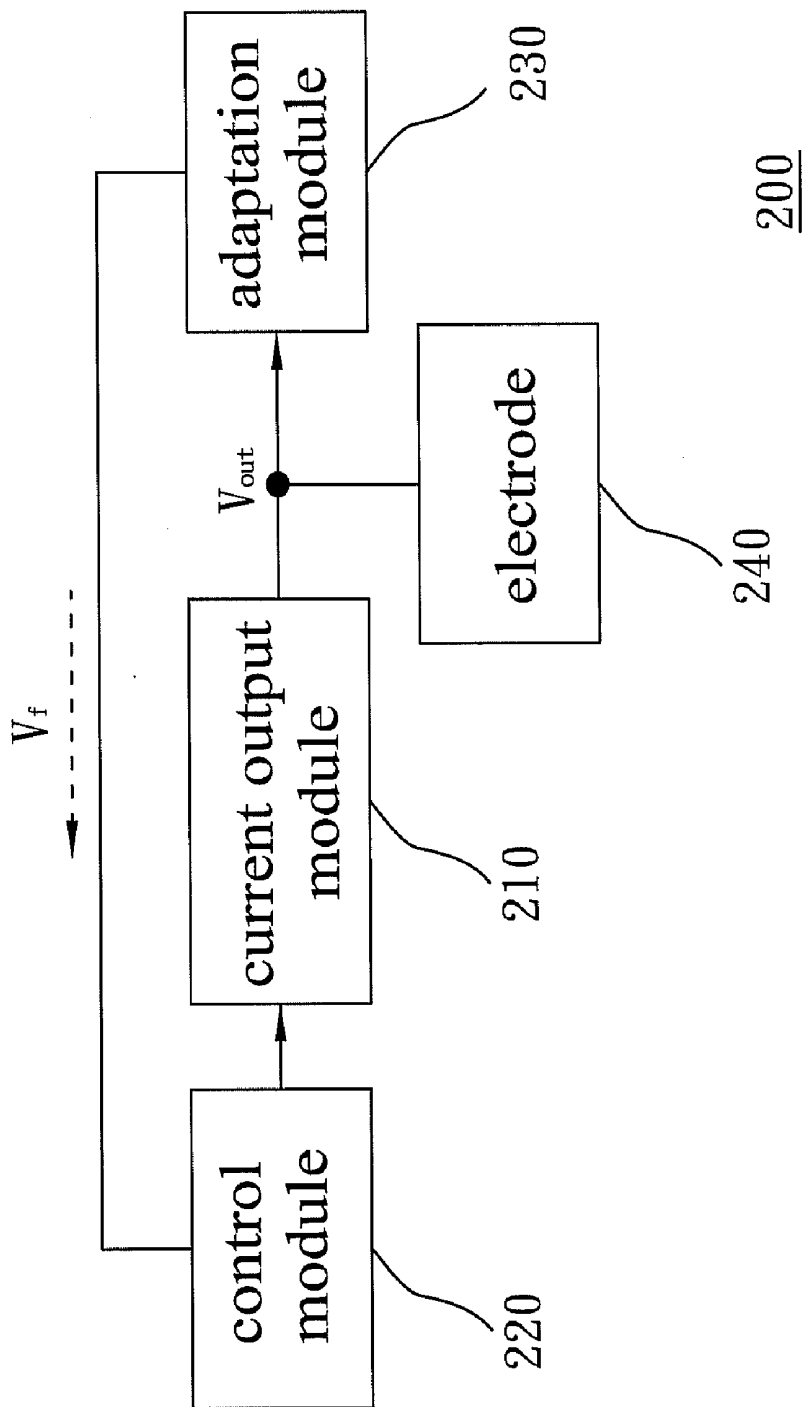

Fig. 2

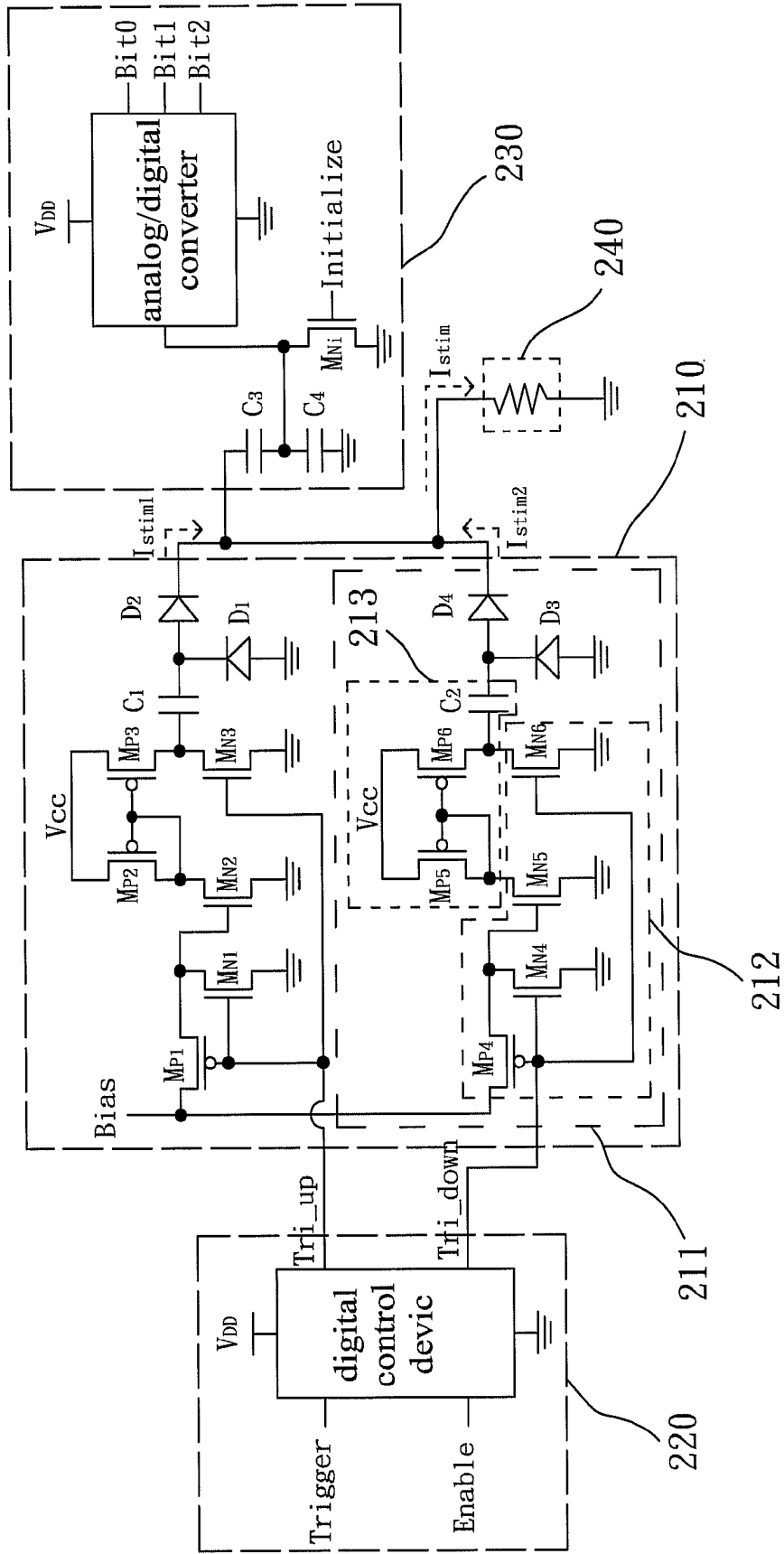

Fig. 3

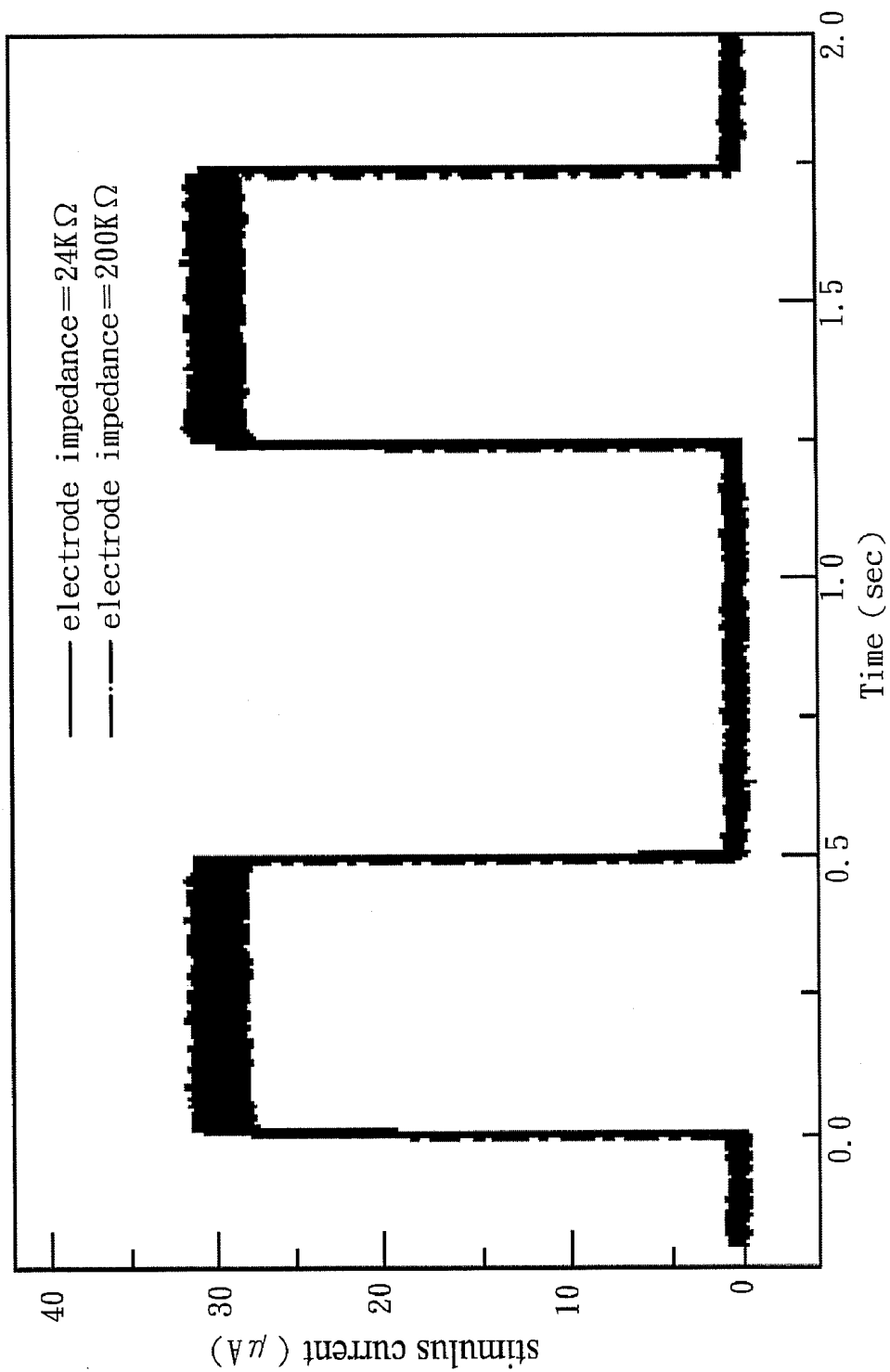

Fig. 4

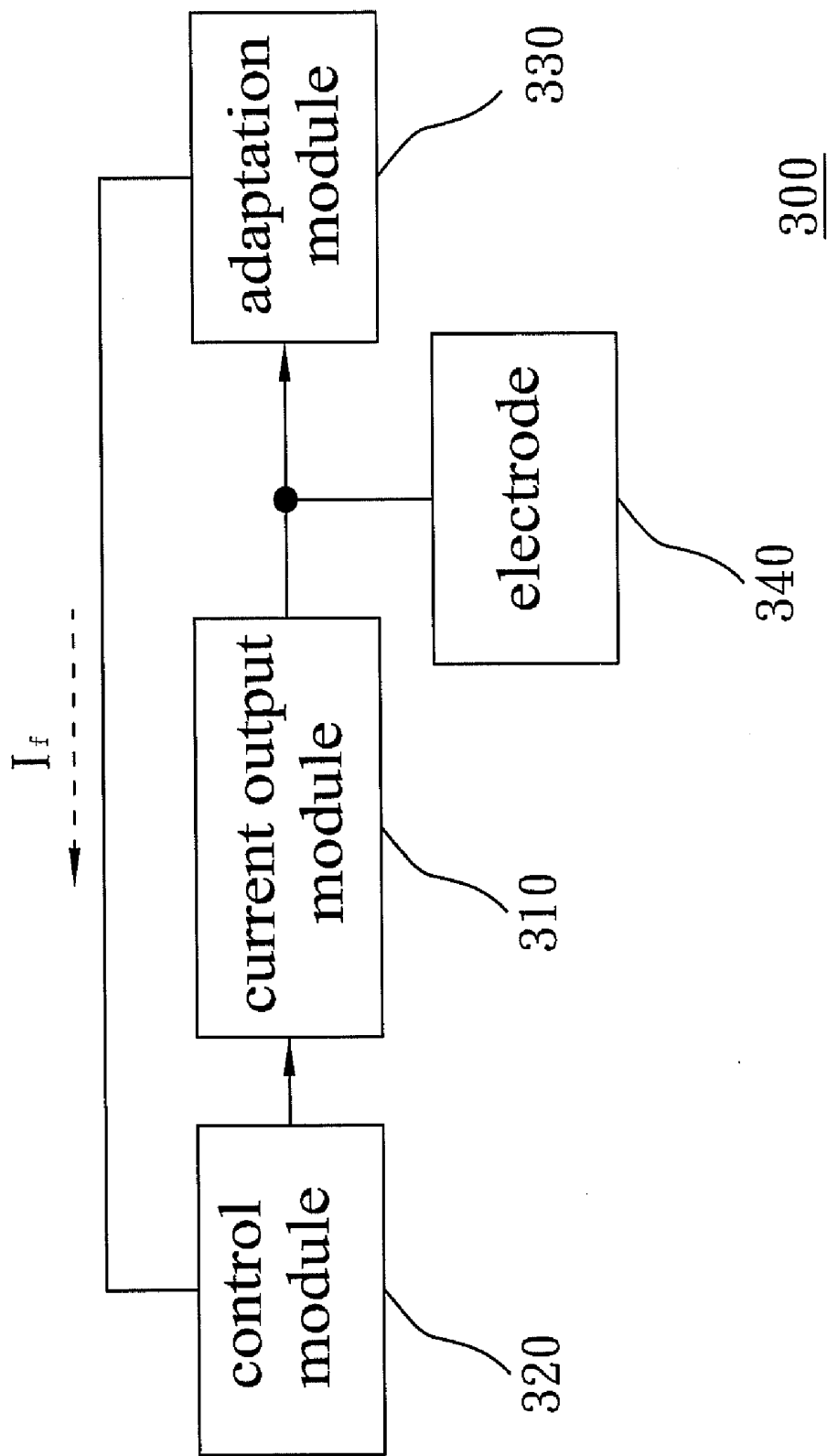

Fig. 5

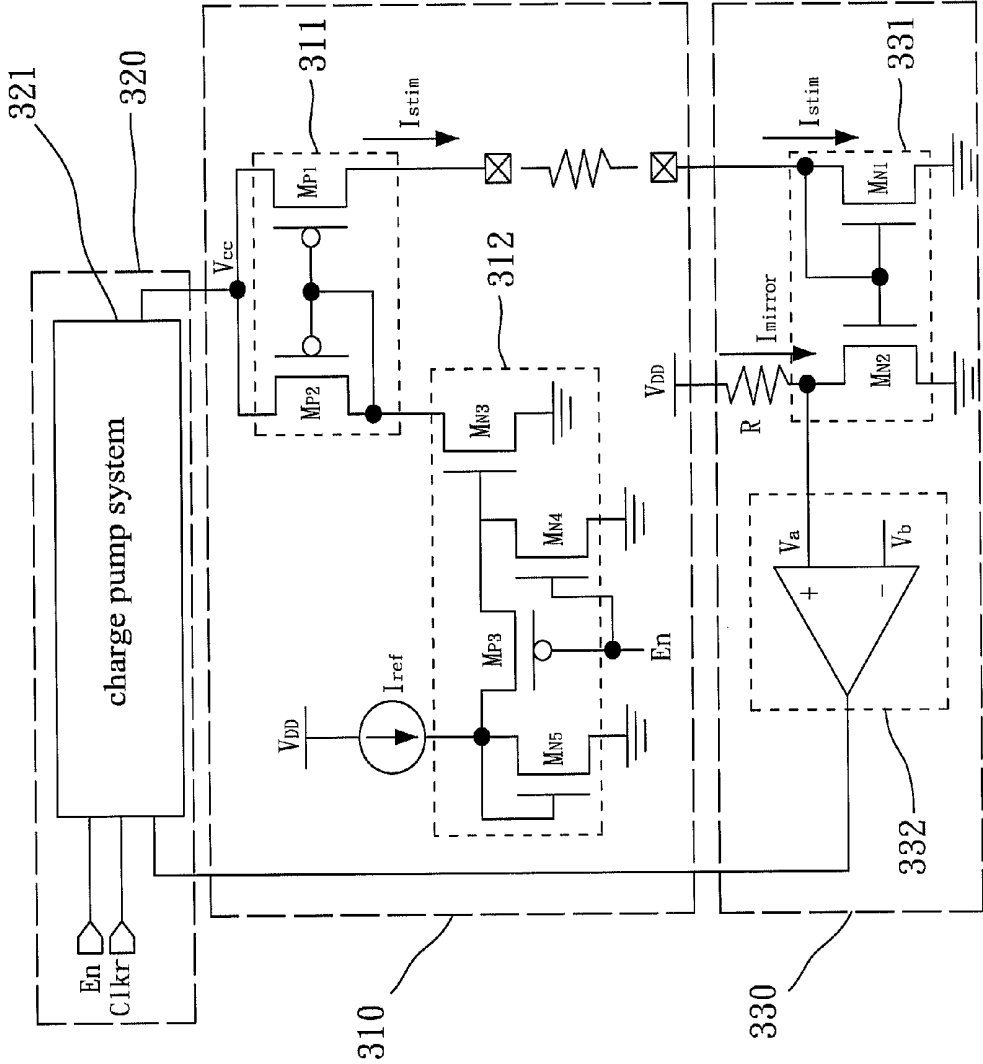

Fig. 6

LOAD-ADAPTIVE BIOELECTRIC CURRENT STIMULATOR

BACKGROUND OF THE INVENTION

[0001] 1. Field of the Invention

[0002] The present invention relates to a stimulator circuit, particularly to a bioelectric current stimulator circuit.

[0003] 2. Description of the Related Art

[0004] The conventional bioelectric current stimulators may be categorized into two types. One type is disposed outside human bodies, and the other type is disposed inside human bodies, functioning as the auxiliary devices of sensory organs. One example of the former is a Taiwan patent No. 1306407 "Device and Method for Generating Biomedical Electronic Signals". Examples of the latter include a U.S. Pat. No. 6,289,246 "High Compliance Output Stage for a Tissue Stimulator" and a U.S. Pat. No. 5,350,407 "Implantable Stimulator Having Quiescent and Active Modes of Operation".

[0005] In applications of the abovementioned stimulators to auxiliary devices of sensor organs, the load impedance ranges from tens of $k\Omega$ to hundreds of $k\Omega$, depending on the contact points on the human or animal body. Even in the same contact point, the load impedance may also vary with the duration of contacting and the material of electrodes. Thus, the conventional stimulators cannot effectively output stimulus current when the load impedance is mismatched.

SUMMARY OF THE INVENTION

[0006] One objective of the present invention is to provide a load-adaptive bioelectric current stimulator, which uses a feedback control mechanism to regulate the stimulus current to adapt to variation of load impedance.

[0007] In one embodiment, the present invention proposes a load-adaptive bioelectric current stimulator, which comprises a current output module, an adaptation module and a control module. The current output module provides a stimulus current for an electrode. The adaptation module detects the electric status of the stimulus current passing through the electrode and generates a feedback signal to the control module. According to the feedback signal, the control module controls the current output module to stabilize the stimulus current adaptively. Thereby, the load-adaptive bioelectric current stimulator of the present invention can use the feedback mechanism to regulate the value of the stimulus current to adapt to the impedance variation of the load according to the special output status of the stimulus current.

[0008] In one embodiment, the adaptation module is an analog/digital conversion circuit. When the stimulus current passes through the electrode and generates an output voltage, the analog/digital conversion circuit provides the control module with a digital voltage signal functioning as a feedback signal according to the output voltage. In such a case, the control module is a digital control device. According to the digital voltage signal, the digital control device outputs an operating signal to the current output module in a PFM (Pulse Frequency Modulation) way to regulate the stimulus current. In one embodiment, the current output module includes a set of complementary current source circuits respectively receiving a set of complementary triggering signals of the operating signal to generate the stimulus current. The current source circuit includes a control circuit and a current mirror, wherein

the control circuit is turned on/off by the corresponding triggering signal of the operating signal.

[0009] Thereby, the adaptation module can obtain the voltage signal of the stimulus current passing through the electrode and feedback a digital voltage signal to the control module, and the control module regulates the stimulus current output by the current output module to adapt to the impedance variation of the load.

[0010] In one embodiment, the adaptation module includes a current mirror and a comparator. The current mirror outputs a differential signal to the comparator according to the stimulus current. The comparator outputs an analog current signal functioning as the feedback signal to the control module according to the differential signal. In such a case, the control module is a charge pump system. According to the analog current signal, the control module controls the working voltage of the current output module and regulates the stimulus current in a PWM (Pulse Width Modulation) way. The current output module includes a control circuit and a current mirror, wherein the current mirror generates the stimulus current when the control circuit is triggered to operate.

[0011] Thereby, the adaptation module can obtain the current signal of the stimulus current passing through the electrode and feedback an analog current signal to the control module, and the control module regulates the stimulus current output by the current output module to adapt to the impedance variation of the load.

BRIEF DESCRIPTION OF THE DRAWINGS

[0012] To make easily understood the objectives, characteristics and advantages of the present invention, embodiments are described in detail in cooperation with the following drawings:

[0013] FIG. 1 a block diagram schematically showing the architecture of a load-adaptive bioelectric current stimulator according to one embodiment of the present invention;

[0014] FIG. 2 a block diagram schematically showing one implementation of the load-adaptive bioelectric current stimulator **100** shown in FIG. 1 according to one embodiment of the present invention;

[0015] FIG. 3 a diagram showing the circuit of the load-adaptive bioelectric current stimulator **200** in FIG. 2 according to one embodiment of the present invention;

[0016] FIG. 4 a diagram showing the waveforms of a bioelectric current stimulator according to one embodiment of the present invention;

[0017] FIG. 5 a block diagram schematically showing another implementation of the load-adaptive bioelectric current stimulator **100** shown in FIG. 1 according to one embodiment of the present invention; and

[0018] FIG. 6 a diagram showing the circuit of the load-adaptive bioelectric current stimulator **300** in FIG. 5 according to one embodiment of the present invention.

DETAILED DESCRIPTION OF THE INVENTION

[0019] Refer to FIG. 1 a block diagram schematically showing the architecture of a load-adaptive bioelectric current stimulator according to one embodiment of the present invention. The load-adaptive bioelectric current stimulator **100** of the present invention comprises a current output module **110**, a control module **120** and an adaptation module **130**. The current output module **110** provides a stimulus current for an electrode **140**. The adaptation module **130** detects the

electric status of the stimulus current passing through the electrode **140** and generates a feedback signal to the control module **120**. According to the feedback signal, the control module **120** controls the current output module **110** to stabilize the stimulus current adaptively lest the stimulus current be influenced by the impedance variation of the load. Thereby, the load-adaptive bioelectric current stimulator **100** of the present invention can use the feedback mechanism to stabilize the stimulus current when the impedance varies with time and environment.

[0020] Refer to FIG. 2 a block diagram schematically showing one implementation of the load-adaptive bioelectric current stimulator **100** shown in FIG. 1 according to one embodiment of the present invention. In this embodiment, a voltage feedback mechanism and a digital control method are used to implement the load-adaptive bioelectric current stimulator **200**. A voltage feedback mechanism is used between the adaptation module **230** and the current output module **210**. When the stimulus current passes through the electrode **240**, the adaptation module **230** detects the output V_{out} and generates a feedback signal to the control module **220** according to the output voltage V_{out} . A digital control method is used between the control module **220** and the current output module **210**, wherein the control module **220** provides an operating signal for the current output module **210**, controlling the value of the stimulus current output by the current output module **210**. Under the abovementioned two technologies, the adaptation module **230** is thus designed to generate a digital voltage signal functioning as a voltage feedback signal V_f to the control module **220** in this embodiment.

[0021] Refer to FIG. 3 a diagram showing the circuit of the load-adaptive bioelectric current stimulator **200** in FIG. 2 according to one embodiment of the present invention. In FIG. 3, the current output module **210** includes a set of complementary current source circuits. The upper current source circuit receives the up triggering signal (Tri_up) of the operating signal, and the lower current source circuit **211** receives the down triggering signal (Tri_down) of the operating signal. It should be noted: the upper current source circuit contributes a stimulus current component I_{stim1} , and the lower current source circuit **211** contributes a stimulus current component I_{stim2} . The sum of I_{stim1} and I_{stim2} is equal to the total stimulus current I_{stim} output to the electrode **240**. Via the instruction of this embodiment, the persons skilled in the art can easily design a current output module **210** containing three or more complementary current source circuits. In this embodiment, the timings of the triggering signals for different current source circuits are controlled to make the current source circuits generate stimulus current components at different time points, whereby is obtained the resultant stimulus current I_{stim} required by different load states.

[0022] The current source circuit **211** includes a control circuit **212** and a current mirror **213**. The control circuit **212** is turned on/off by the corresponding triggering signal of the operating signal, i.e. the down triggering signal Tri_down. When the control circuit **212** is turned on by the down triggering signal Tri_down, the current mirror **213** generates the stimulus component I_{stim2} . The control module **220** respectively provides the up triggering signal Tri_up and the down triggering signal Tri_down for the upper current source circuit and the lower current source circuit **211**. When the up triggering signal Tri_up is at a low level V_{SS} , it turns on the upper current source circuit. Meanwhile, the down triggering

signal Tri_down is at a high level V_{DD} and turns off the lower current source circuit **211**. In the upper current source circuit, when a transistor M_{N2} is biased by a transistor M_{P1} , a transistor M_{N3} is turned off. In such a case, the stimulus current component I_{stim1} is transmitted by the current mirror, i.e. a transistor M_{P2} and a transistor M_{P3} , and then passes a capacitor C_1 and a diode D_2 . Simultaneously, the lower current source circuit **211** is at a discharging state. In such a case, a transistor M_{N5} is turned off, and a transistor M_{N6} is turned on; a capacitor C_2 , which has been charged in the last operating cycle, discharges via the transistor M_{N6} and a diode D_3 .

[0023] In another operating cycle, when the lower current source circuit **211** is turned on by the down triggering signal Tri_down, the up triggering signal Tri_up is at a high level V_{DD} , and the down triggering signal Tri_down is at a low level V_{SS} . In such a case, the transistor M_{N2} of the control circuit **212** is turned off, and the transistor M_{N3} of the control circuit **212** is turned on. Thus, the capacitor C_1 , which has been charged, discharges via the transistor M_{N3} and the diode D_1 . Meanwhile, the lower current source circuit **211** is at a working state, and the stimulus current component I_{stim2} is transmitted by the current mirror **213** that consists of a transistor M_{P5} and a transistor M_{P6} and then passes the capacitor C_2 and a diode D_4 . During the operation interruption of the current output module **210**, the up triggering signal Tri_up and the down triggering signal Tri_down are at a high level V_{DD} , and the gates of the transistor M_{N2} and the transistor M_{N3} are at a low level V_{SS} and turned off. Thus, no stimulus current I_{stim} is transmitted.

[0024] In one embodiment, the adaptation module **230** is an analog/digital conversion circuit. The adaptation module **230** obtains the voltage signal of the stimulus current I_{stim} , which passes through the load **240**, via a capacitor C_3 and a capacitor C_4 and then uses an analog/digital converter to generate a digital feedback voltage signal Bit 0, Bit 1 or Bit 2. In such a case, the control module is a digital control device. The digital feedback signal is used as a triggering signal Trigger. The triggering signal Trigger together with an enabling signal Enable of the bioelectric current stimulator is used to implement a PFM control activity, whereby to generate an operating signal containing a plurality of triggering signals required by the current source circuits, such as the up triggering signal Tri_up and the down triggering signal Tri_down.

[0025] Refer to FIG. 4 for the waveforms of a bioelectric current stimulator according to one embodiment of the present invention. The equivalent impedance of the electrode **240** may vary from 20 to 200 Ω with time, tissues, or materials. However, the stimulus current I_{stim} should not vary anyway. The bioelectric current stimulator shown in FIG. 3 provides 30 μ A stimulus current stably and thus can indeed overcome the problem of the conventional technology. Refer to FIG. 5 a block diagram schematically showing another implementation of the load-adaptive bioelectric current stimulator **100** shown in FIG. 1 according to one embodiment of the present invention. In this embodiment, a current feedback mechanism and an analog control method are used to implement the load-adaptive bioelectric current stimulator **300**. A current feedback mechanism is used between the adaptation module **330** and the current output module **310**. When the stimulus current passes through the electrode **340**, the adaptation module **330** detects the output current and generates a feedback signal to the control module **320** according to the output current. The adaptation module **330** may detect the output current via a Helmholtz core or a pair of

electrodes **340** that form a current loop. Moreover, an analog control method is used between the control module **320** and the current output module **310**. For example, the control module **320** directly controls the value of the stimulus current of the current output module **310**. The control module **320** generates a working voltage to the current output module **310** according to the enabling signal En of the bioelectric current stimulator. The current output module **310** generates a stimulus current to the electrode **340** according to the enabling signal En. The adaptation module **330** detects the value of the stimulus current that has been influenced by the impedance matching of the electrode **340** and generates an analog current signal functioning as a feedback current signal I_f to the control module **320**. Thereby, the control module **320** modifies the working voltage according to the value of the stimulus current to overcome the influence of the impedance variation of the electrode **340**. Thus is stabilized the stimulus current. According to the instructions shown in FIG. 2 and FIG. 5, the persons having ordinary knowledge of the art should be able to choose an appropriate feedback mechanism and design a corresponding control method for the bioelectric current stimulator of the present invention.

[0026] Refer to FIG. 6 a diagram showing the circuit of the load-adaptive bioelectric current stimulator **300** in FIG. 5 according to one embodiment of the present invention. In FIG. 6, there is a pair of electrodes **340** forming a current loop. The current output module **310** includes a current mirror **311** and a control circuit **312**. The enabling signal En turns on/off the control circuit **312**. When the control circuit **312** is turned on, the current mirror **311** generates a stimulus current I_{stim} . It should be noted that the working voltage V_{CC} of the current mirror **311** is directly controlled by the control module **320**. When the control module **320** adjusts the working voltage V_{CC} according to the feedback signal, the value of the stimulus current I_{stim} is also adjusted correspondingly. In details, when the enabling signal En turns on the transistor M_{P3} and turns off the transistor M_{N4} , the transistor M_{N3} is turned on to make the current mirror **311** generate a stimulus current I_{stim} . When the enabling signal En turns off the transistor M_{P3} and turns on the transistor M_{N4} , the transistor M_{N3} is turned off to make the current mirror **311** unable to generate a stimulus current

[0027] I_{stim} .

[0028] The adaptation module **330** includes a current mirror **331** and a comparator **332**. The current mirror **331** generates a mirrored current I_{mirror} according to the stimulus current I_{stim} . Via a resistor R, the mirrored current I_{mirror} generates an electric potential V_a to the comparator **332**. The comparator **332** further obtains a reference potential V_b . Thus, the potential V_a and the potential V_b form a differential signal. According to the differential signal, the comparator **332** generates an analog current signal functioning as a feedback current signal I_f . In one embodiment, the control module **321** is a charge pump system. According to the enabling signal En and clock signal Clkr that control the bioelectric current stimulator and the analog current signal, the charge pump system performs a PWM control activity to control the working voltage V_{CC} of the current mirror **311** of the current output module **310**. Thus, the feedback control mechanism of the bioelectric current stimulator of the present invention can offset the time- and environment-dependent impedance variation of the load.

[0029] The embodiments described above are only to exemplify the present invention but not to limit the scope of the present invention. Any equivalent modification or variation made by the persons skilled in the art according to the spirit of the present invention is to be also included within the scope of the present invention.

What is claimed is:

1. A load-adaptive bioelectric current stimulator comprising:

a current output module generating a stimulus current to an electrode;

an adaptation module detecting an electric status of said stimulus current when said stimulus current passes through said electrode, and generating a feedback signal; and

a control module controlling said current output module according to said feedback signal to stabilize output of said stimulus current adaptively.

2. The load-adaptive bioelectric current stimulator according to claim 1, wherein said adaptation module is an analog/digital conversion circuit, and said analog/digital conversion circuit provides a digital voltage signal for said control module as said feedback signal according to an output voltage generated by said stimulus current when said stimulus current passes through said electrode.

3. The load-adaptive bioelectric current stimulator according to claim 2, wherein said control module is a digital control device, and according to said digital voltage signal, said digital control device provides said current output module with an operating signal in a PFM (Pulse Frequency Modulation) way to regulate said stimulus current.

4. The load-adaptive bioelectric current stimulator according to claim 3, wherein said current output module includes a set of complementary current source circuits receiving a set of complementary triggering signals of said operating signal respectively and generating said stimulus current.

5. The load-adaptive bioelectric current stimulator according to claim 4, wherein each said current source circuit includes a control circuit and a current mirror, and said control circuit is turned on/off by a corresponding said triggering signal.

6. The load-adaptive bioelectric current stimulator according to claim 1, wherein said adaptation module includes a current mirror and a comparator, said current mirror generates a differential signal to said comparator according to said stimulus current, and said comparator generates an analog current signal to said control module as said feedback signal according to said differential voltage.

7. The load-adaptive bioelectric current stimulator according to claim 6, wherein said control module is a charge pump system, and according to said analog current signal, said charge pump system controls a working voltage output by said current output module in a PWM (Pulse Width Modulation) way to regulate said stimulus current.

8. The load-adaptive bioelectric current stimulator according to claim 7, wherein said current output module includes a control circuit and a current mirror, and when said control circuit is activated, said current output module generates said stimulus current via said current mirror.

* * * * *