



(19) **United States**

(12) **Patent Application Publication**
Chang et al.

(10) **Pub. No.: US 2012/0122281 A1**
(43) **Pub. Date: May 17, 2012**

(54) **METHOD FOR FABRICATING A GAN-BASED THIN FILM TRANSISTOR**

Publication Classification

(75) Inventors: **Yi Chang**, Hsinchu City (TW);
Chia-Hua Chang, Taichung City (TW);
Yueh-Chin Lin, New Taipei City (TW)

(51) **Int. Cl.**
H01L 21/336 (2006.01)
(52) **U.S. Cl.** **438/151; 257/E21.411**

(73) Assignee: **NATIONAL CHIAO TUNG UNIVERSITY**, Hsinchu (TW)

(57) **ABSTRACT**

(21) Appl. No.: **13/117,428**

(22) Filed: **May 27, 2011**

A method for fabricating a GaN-based thin film transistor includes: forming a semiconductor epitaxial layer on a substrate, the semiconductor epitaxial layer having a n-type GaN-based semiconductor material; forming an insulating layer on the semiconductor epitaxial layer; forming an ion implanting mask on the insulating layer, the ion implanting mask having an opening to partially expose the insulating layer; ion-implanting a p-type impurity through the opening and the insulating layer to form a p-doped region in the n-type GaN-based semiconductor material, followed by removing the insulating layer and the ion implanting mask; forming a dielectric layer on the semiconductor epitaxial layer; partially removing the dielectric layer; forming source and drain electrodes; and forming a gate electrode.

(30) **Foreign Application Priority Data**

Nov. 12, 2010 (TW) 099139011

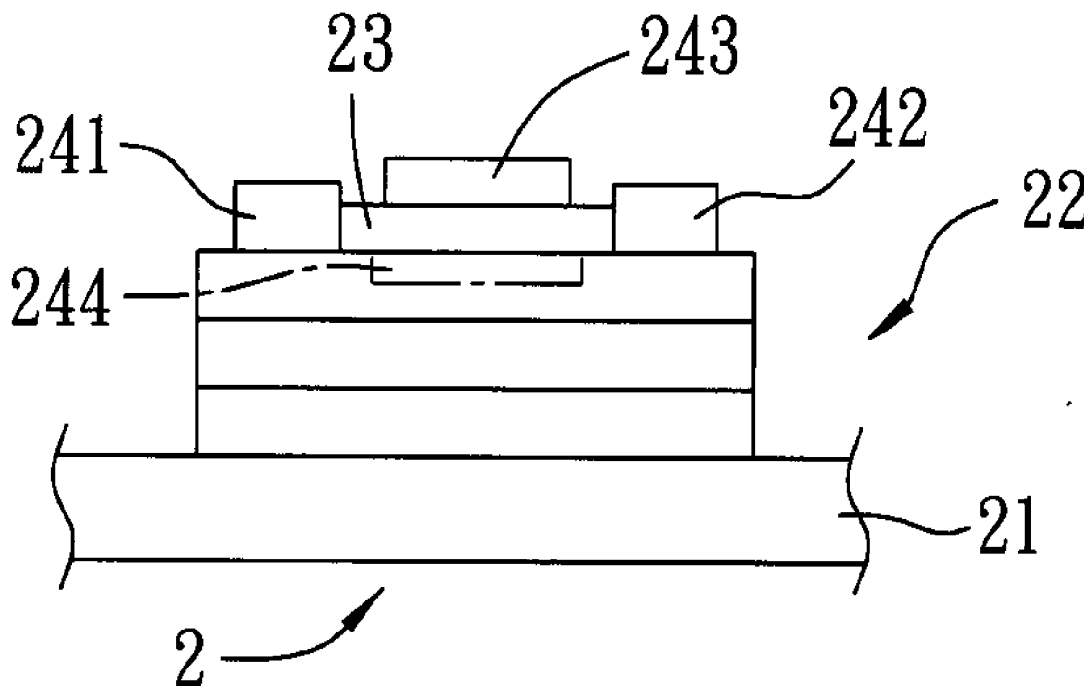

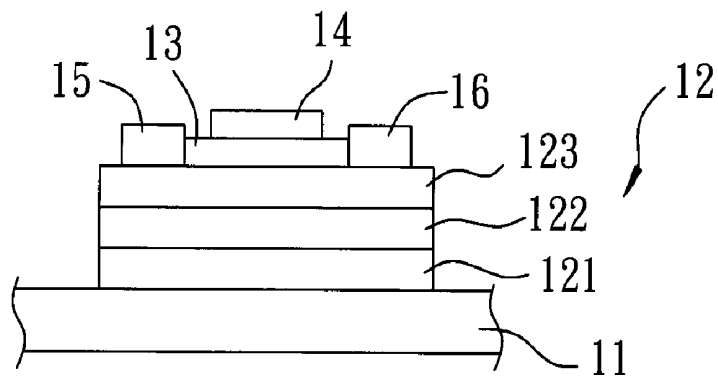

FIG. 1
PRIOR ART

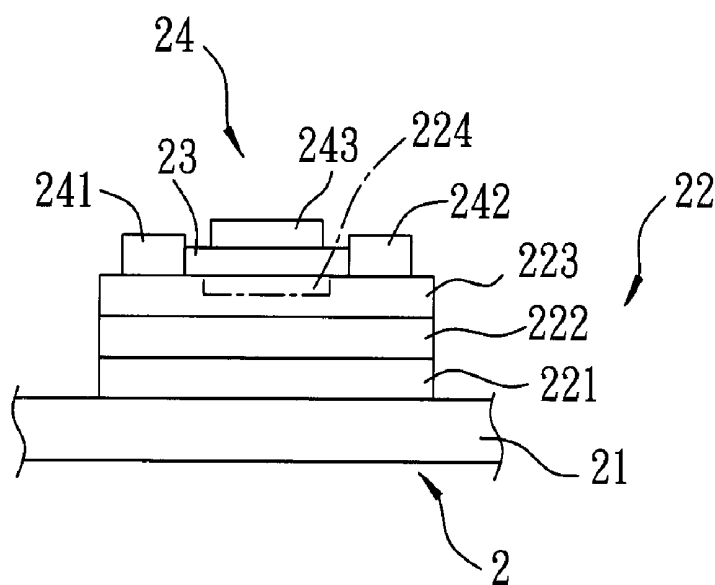

FIG. 2

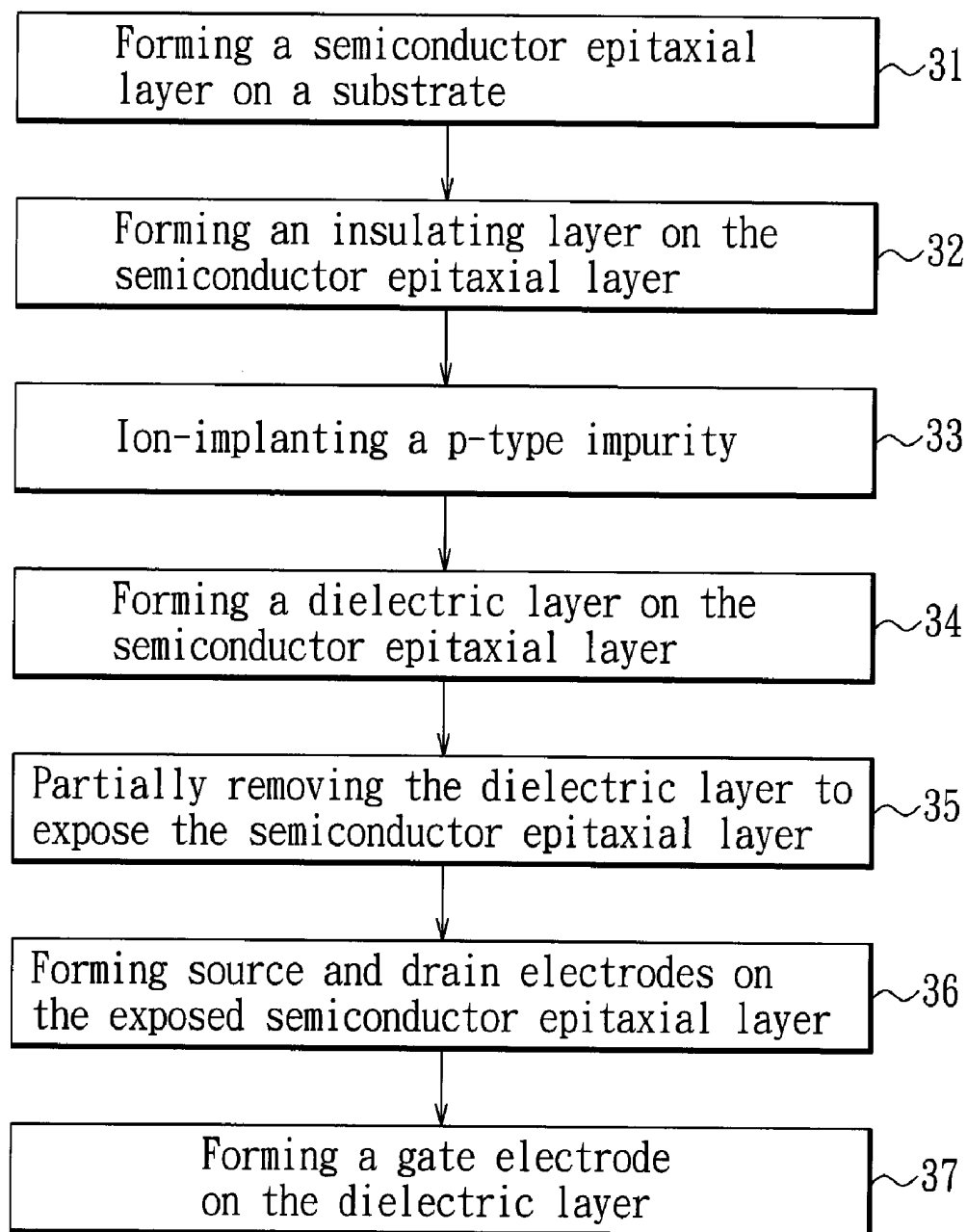
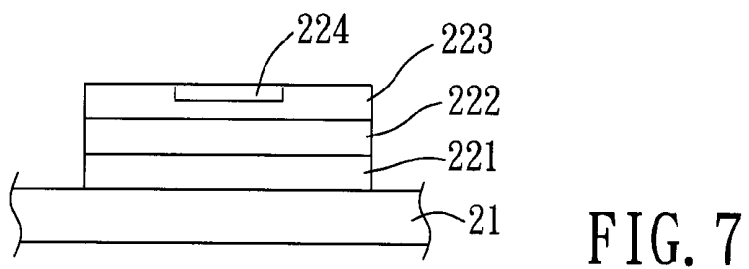
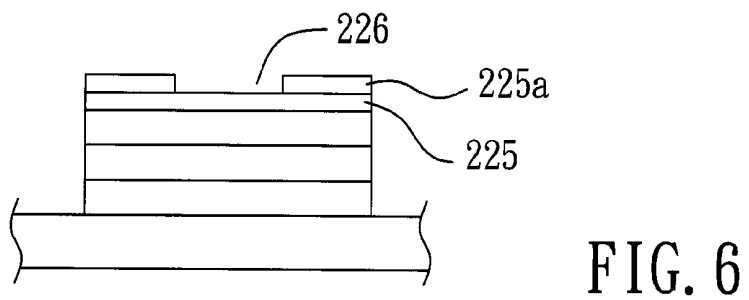
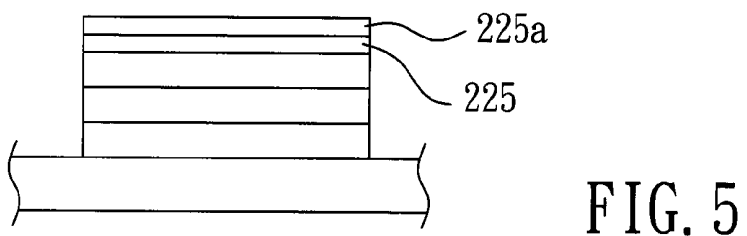
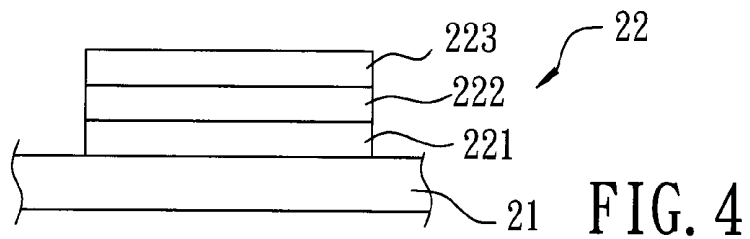

FIG. 3



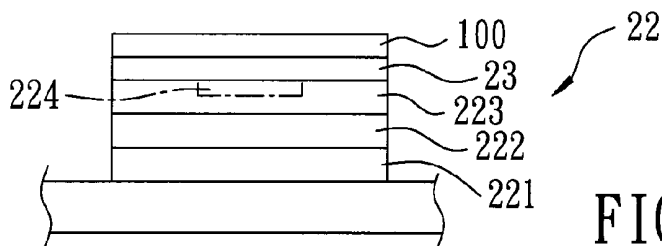

FIG. 8

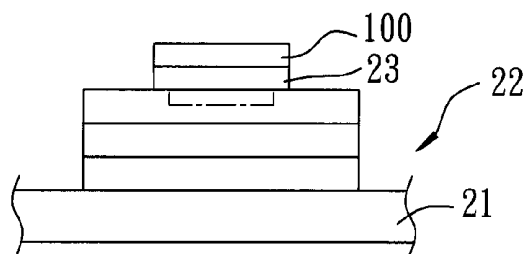

FIG. 9

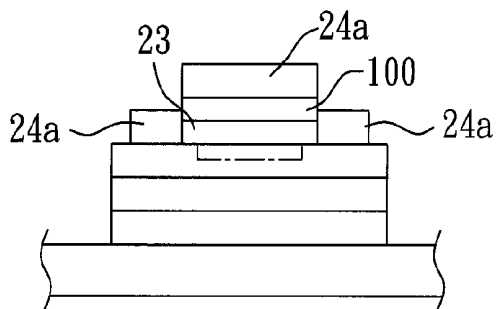

FIG. 10

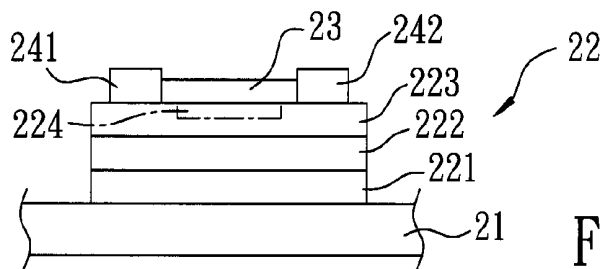

FIG. 11

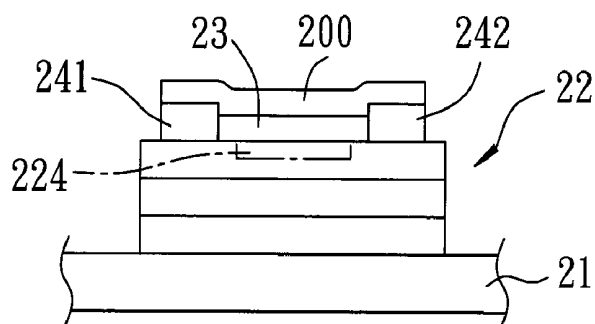

FIG. 12

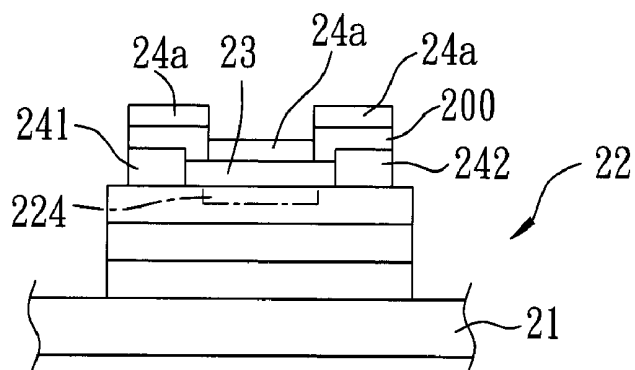

FIG. 13

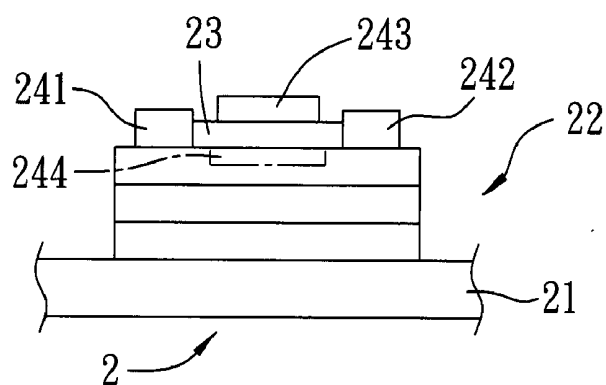

FIG. 14

METHOD FOR FABRICATING A GAN-BASED THIN FILM TRANSISTOR

CROSS-REFERENCE TO RELATED APPLICATION

[0001] This application claims priority of Taiwanese application no. 099139011, filed on Nov. 12, 2010.

BACKGROUND OF THE INVENTION

[0002] 1. Field of the Invention

[0003] This invention relates to a method for fabricating a gallium nitride-based (GaN-based) thin film transistor, more particularly to a method for fabricating an enhancement mode (E-mode) GaN-based thin film transistor.

[0004] 2. Description of the Related Art

[0005] Referring to FIG. 1, a conventional GaN-based thin film transistor includes a substrate **11**, a semiconductor layer **12**, a dielectric layer **13** disposed on a top surface of the semiconductor layer **12**, source and drain electrodes **15**, **16** respectively formed on two opposite sides of the dielectric layer **13**, and a gate electrode **14** disposed on a top surface of the dielectric layer **13** and between the source and drain electrodes **15**, **16**. The semiconductor layer **12** includes, from bottom to top, a first GaN epitaxial film **121** formed on the substrate **11**, an aluminum gallium nitride (AlGa_N) epitaxial film **122**, and a second GaN epitaxial film **123** connected to the dielectric layer **13**.

[0006] In the conventional GaN-based thin film transistor, since two dimensional electron gas (2DEG) is induced by a mass of polarization charges in the first GaN epitaxial film **121** and the AlGa_N epitaxial film **122**, the transistor is required to be operated in a depletion-mode. Such transistor is also referred to as a “normally on” transistor. The “normally on” transistor has a negative threshold voltage, and thus, consumes power even at zero gate bias. This results in additional power loss. Besides, when the transistor is used in a high power circuit system, a transient pulse voltage is likely to occur since the high power circuit system is required to be operated at an extremely high bias voltage. A malfunction of the high power circuit system caused by the “abnormally on” state of the high power element (the transistor) tends to occur due to insufficient high threshold voltage of the transistor. Hence, the stability of the high power circuit system may be adversely affected.

[0007] In order to provide an improved GaN thin film transistor that has a relatively high threshold voltage, an improved high voltage endurance, and a relatively high power output, and that is operated at an enhancement mode (E-mode), U.S. Pat. No. 7,655,962 discloses an enhancement mode transistor including a bottom AlInGa_N barrier layer disposed under an AlInGa_N channel layer so that polarization charges of the bottom barrier layer deplete charges in the channel layer. The transistor of U.S. Pat. No. 7,655,962 also includes a gate electrode formed as a deep recessed gate so that the transistor is in the off state at zero gate bias.

[0008] Furthermore, U.S. Patent Application Publication No. 2007/0295993 discloses a high electron mobility transistor made by introducing fluorine ions into an AlInGa_N channel layer using a CF₄ plasma treatment to effectively deplete charges in the AlInGa_N channel layer. Accordingly, the transistor is in the off state at zero gate bias, and can serve as an E-mode transistor.

[0009] However, formation of the deep recessed gate described in U.S. Pat. No. 7,655,962 requires a surface etching process. This may result in an increased surface state density of the transistor that is likely to adversely affect current characteristics and reliability of the transistor. Besides, although the threshold voltage of the transistor described in U.S. Patent Application Publication No. 2007/0295993 can be increased by introducing the fluorine ions using the CF₄ plasma treatment, it can be increased only by 0.9 volt due to a limited diffusion capability of the fluorine ions, and is thus unsatisfactory.

SUMMARY OF THE INVENTION

[0010] Therefore, an object of the present invention is to provide a method for fabricating a GaN-based thin film transistor that can overcome the aforesaid drawbacks associated with the prior art.

[0011] Accordingly, a method for fabricating a GaN-based thin film transistor of this invention comprises:

[0012] forming a semiconductor epitaxial layer on a substrate, the semiconductor epitaxial layer having a n-type GaN-based semiconductor material;

[0013] forming an insulating layer on the semiconductor epitaxial layer;

[0014] forming an ion implanting mask on the insulating layer, the ion implanting mask having an opening to partially expose the insulating layer;

[0015] ion-implanting a p-type impurity through the opening and the insulating layer to form a p-doped region in the n-type GaN-based semiconductor material, followed by removing the insulating layer and the ion implanting mask;

[0016] forming a dielectric layer on the semiconductor epitaxial layer;

[0017] partially removing the dielectric layer so that two portions of the semiconductor epitaxial layer that are located on two opposite sides of the p-doped region are exposed from the dielectric layer;

[0018] forming source and drain electrodes respectively on the two portions of the semiconductor epitaxial layer; and

[0019] forming a gate electrode on a remaining portion of the dielectric layer.

BRIEF DESCRIPTION OF THE DRAWINGS

[0020] Other features and advantages of the present invention will become apparent in the following detailed description of the preferred embodiment of the invention, with reference to the accompanying drawings, in which:

[0021] FIG. 1 is a schematic view of a conventional GaN-based thin film transistor;

[0022] FIG. 2 is a schematic view of the preferred embodiment of a GaN-based thin film transistor according to the present invention;

[0023] FIG. 3 is a flow chart showing the preferred embodiment of a method for fabricating a GaN-based thin film transistor according to the present invention; and

[0024] FIGS. 4 to 14 are schematic views illustrating successive steps of the method for fabricating a GaN-based thin film transistor according to the present invention.

DETAILED DESCRIPTION OF THE PREFERRED EMBODIMENT

[0025] A GaN-based thin film transistor **2** made by the preferred embodiment of the method for fabricating a GaN-based thin film transistor according to this invention is shown in FIGS. 2 and 14.

[0026] The GaN-based thin film transistor **2** includes a substrate **21**, a semiconductor epitaxial layer **22**, a dielectric layer **23**, and an electrode unit **24**.

[0027] The substrate **21** may be made of a transparent or non-transparent insulating material, such as sapphire, silicon, or silicon carbide. Because the materials suitable for making the substrate **21** and the semiconductor epitaxial layer **22** are well-known in the relevant art and can be selected by a skilled artisan based on the intended use, detailed descriptions thereof are omitted for the sake of brevity.

[0028] In the preferred embodiment, the substrate **21** is made of sapphire. The semiconductor epitaxial layer **22** is made of a n-type GaN-based semiconductor material, and includes, from bottom to top, a first GaN epitaxial film **221** formed on the substrate **21**, an AlGaN epitaxial film **222**, a second GaN epitaxial film **223**, and a p-doped region **224** formed in the second GaN epitaxial film **223** and extending downwardly from a top surface of the second GaN epitaxial film **223**.

[0029] The dielectric layer **23** is formed on the top surface of the second GaN epitaxial film **223** to cover the p-doped region **224**, and is made of a material having a relatively high dielectric constant. Accordingly, the numbers of carriers and charges in the AlGaN epitaxial film **222** can be increased to raise the threshold voltage of the transistor. Examples of the materials suitable for the dielectric layer **23** include Al_2O_3 , HfO_2 , La_2O_3 , CeO_2 , HfAlO , TiO_2 , and ZrO_2 .

[0030] The electrode unit **24** is made of a conductive material, and includes a source electrode **241**, a drain electrode **242**, and a gate electrode **243**. The source and drain electrodes **241**, **242** are formed on the top surface of the second GaN epitaxial film **223** so as to be respectively disposed on two opposite sides of the dielectric layer **23**. The gate electrode **243** is formed on a surface of the dielectric layer **23** opposite to the p-doped region **224**.

[0031] The GaN-based semiconductor material itself has a n-type property that has electrons as major carriers, and thus, a p-n junction is formed between the p-doped region **224** and the second GaN epitaxial film **223**. Since the p-n junction in the semiconductor epitaxial layer **22** produces an internal p-n junction voltage, and since the dielectric layer **23** is formed on the p-doped region **224**, the threshold voltage of the transistor according to the present invention can be effectively increased and current leakage of the transistor may be alleviated. Furthermore, the drain output current and trans conductance of the transistor can also be improved, and thus, the transistor of this invention can serve as an E-mode transistor for next generation high efficiency and high voltage driving and controlling circuit system.

[0032] The GaN-based thin film transistor is explained in more detail below through steps of the method for fabricating the GaN-based thin film transistor according to this invention (see FIG. 3).

[0033] In step **31**, the semiconductor epitaxial layer **22** is formed on the substrate **21** made of sapphire. In this step, the semiconductor epitaxial layer **22** includes a three-layer structure of the first GaN epitaxial film **221** formed on the substrate **21**, the AlGaN epitaxial film **222**, and the second GaN epitaxial film **223** in that order (see FIG. 4).

[0034] In step **32**, an insulating layer **225** is formed on the second GaN epitaxial film **223** of the semiconductor epitaxial layer **22**, and an ion implanting mask **225a** is formed on the insulating layer **225** (see FIG. 5). Thereafter, the ion implanting mask **225a** is formed to have the opening **226** using a

lithography process to partially expose the insulating layer **225** (see FIG. 6). In this step, the insulating layer **225** is formed using plasma enhanced chemical vapor deposition (PECVD), and is made of silicon dioxide, silicon nitride, aluminum oxide, or other insulating materials. The ion implanting mask **225a** is formed by coating a photoresist material that maybe a positive-type or a negative-type on the insulating layer **225**, followed by a lithography process to form the opening **226**. The selection of the photoresist material and the lithography process are well-known to the skilled artisan, and detailed descriptions thereof are omitted for the sake of brevity.

[0035] It should be noted that the insulating layer **225** has a thickness arranged to control a depth of the p-doped region **224** so that the p-doped region **224** is formed only in the second GaN epitaxial film **223**. If the thickness of the insulating layer **225** is overly large, ions (i.e., p-type impurities) cannot be doped in the semiconductor epitaxial layer **22**. If the insulating layer **225** is overly thin, the ions may extend through a predetermined region for ion implanting (i.e., the p-n junction cannot be formed). Preferably, the thickness of the insulating layer **225** is not less than 50 nm. More preferably, the thickness of the insulating layer **225** ranges from 50 nm to 150 nm.

[0036] In step **33**, a p-type impurity is ion-implanted through the opening **226** and the insulating layer **225** to form the p-doped region **224** in the second GaN epitaxial film **223**, followed by removing the insulating layer **225** and the ion implanting mask **225a** (see FIG. 7).

[0037] Specifically, the p-type impurity is selected from ions for forming the p-doped region **224** in a GaN material, such as magnesium ions, boron ions, etc.

[0038] It should be noted that if the p-doped region **224** has a thickness that is overly large, formation of a two dimensional electron gas (2DEG) channel by virtue of the second GaN epitaxial film **223** and the AlGaN epitaxial film **222** would be adversely affected. If the thickness of the p-doped region **224** is not enough, the threshold voltage (i.e., the turn-on voltage) of the transistor cannot be effectively increased. Preferably, the thickness of the p-doped region **224** is less than one-half of a thickness of the second GaN epitaxial film **223**.

[0039] In step **34**, the dielectric layer **23** is formed on the semiconductor epitaxial layer **22** (see FIG. 8).

[0040] Thereafter, in step **35**, the dielectric layer **23** is partially removed according to the following sub-steps. A photoresist **100** is formed on the dielectric layer **23** (see FIG. 8). Then, the photoresist **100** is processed by lithography to cover a portion of the dielectric layer **23** that is located above the p-doped region **224**, and the dielectric layer **23** exposed from the photoresist **100** is removed (see FIG. 9). Accordingly, two portions of the semiconductor epitaxial layer **22** that are located on two opposite sides of the p-doped region **224** are exposed from the dielectric layer **23**.

[0041] In step **36**, the source and drain electrodes **241**, **242** are respectively formed on the two portions of the semiconductor epitaxial layer **22** according to the following sub-steps. In detail, the source and drain electrodes **241**, **242** shown in FIG. 11 are formed by depositing a metal material **24a** on the photoresist **100** and the two portions of the semiconductor epitaxial layer **22** (see FIG. 10), followed by removing the photoresist **100**.

[0042] In step **37**, the gate electrode **243** is formed on a remaining portion of the dielectric layer **23** to obtain the

GaN-based thin film transistor **2**. In detail, the gate electrode **243** shown in FIG. **14** is formed by: forming a photoresist **200** to cover the remaining portion of the dielectric layer **23**, and the source and drain electrodes **241**, **242** (see FIG. **12**); partially removing a portion of the photoresist **200** using lithography to partially expose the remaining portion of the dielectric layer **23**, the removed portion of the photoresist **200** being aligned with the p-doped region **224**; depositing the metal material **24a** on the exposed dielectric layer **23** and the remaining photoresist **200** (see FIG. **13**); and removing the photoresist **200** and the metal material **24a** on the photoresist **200** to obtain the gate electrode **243** (see FIG. **14**).

[0043] Preferably, the method of this invention further includes a step of introducing fluorine ions to the AlGaN epitaxial film **222** through the opening **226** by CF_4 plasma treating, before the step of ion-implanting (step **33**). Accordingly, the threshold voltage (i.e., the turn-on voltage) of the transistor **2** can be further increased.

[0044] In summary, the transistor **2** of this invention is made by directly ion-implanting the p-type impurity in the n-type GaN-based semiconductor material to obtain the p-n junction that can produce the internal p-n junction voltage to increase the threshold voltage of the transistor **2**. Thus, the transistor **2** of this invention, which is relatively easy to make and to control, can be operated at the E-mode. Besides, since the p-doped region **224** is formed by ion-implanting, it is not necessary to form a p-type epitaxial film on the n-type GaN-based semiconductor material, which may cause a problem of interfacial defects. Furthermore, since the transistor **2** of this invention is not formed by the conventional method, a problem of increased defect density due to an etching process for forming the deep recessed gate as in the prior art, or a problem that a relatively high threshold voltage is unable to be achieved even through the use of plasma treatment can be avoided. On the other hand, because the dielectric layer **23** of the transistor **2** of this invention has the relatively high dielectric constant, the threshold voltage of the transistor **2** can be further increased and current leakage can be alleviated. Therefore, the transistor **2** of this invention has a relatively low standby power loss, and can be easily applied to an electric system, such as the next-generation high efficiency and high voltage driving and controlling circuit system to serve as an E-mode transistor.

[0045] While the present invention has been described in connection with what is considered the most practical and preferred embodiment, it is understood that this invention is not limited to the disclosed embodiment but is intended to cover various arrangements included within the spirit and scope of the broadest interpretations and equivalent arrangements.

What is claimed is:

1. A method for fabricating a GaN-based thin film transistor, comprising:
 - forming a semiconductor epitaxial layer on a substrate, the semiconductor epitaxial layer having a n-type GaN-based semiconductor material;
 - forming an insulating layer on the semiconductor epitaxial layer;
 - forming an ion implanting mask on the insulating layer, the ion implanting mask having an opening to partially expose the insulating layer;
 - ion-implanting a p-type impurity through the opening and the insulating layer to form a p-doped region in the n-type GaN-based semiconductor material, followed by removing the insulating layer and the ion implanting mask;
 - forming a dielectric layer on the semiconductor epitaxial layer;
 - partially removing the dielectric layer so that two portions of the semiconductor epitaxial layer that are located on two opposite sides of the p-doped region are exposed from the dielectric layer;
 - forming source and drain electrodes respectively on the two portions of the semiconductor epitaxial layer; and
 - forming a gate electrode on a remaining portion of the dielectric layer.
2. The method of claim **1**, wherein the semiconductor epitaxial layer includes, from bottom to top, a first GaN epitaxial film formed on the substrate, an AlGaN epitaxial film, and a second GaN epitaxial film.
3. The method of claim **2**, wherein the insulating layer has a thickness arranged to limit a depth of the p-doped region so that the p-doped region is formed only in the second GaN epitaxial film.
4. The method of claim **3**, wherein the p-doped region has a thickness less than one-half of a thickness of the second GaN epitaxial film.
5. The method of claim **2**, further comprising a step of introducing fluorine ions to the AlGaN epitaxial film through the opening by plasma treating, before the step of ion-implanting.
6. The method of claim **3**, wherein the insulating layer is made of one of silicon dioxide and silicon nitride, and has the thickness ranging from 50 nm to 150 nm.
7. The method of claim **1**, wherein the dielectric layer is made of a material selected from the group consisting of Al_2O_3 , HfO_2 , La_2O_3 , CeO_2 , $HfAlO$, TiO_2 , and ZrO_2 .

* * * * *