



(19) **United States**

(12) **Patent Application Publication**  
Fan et al.

(10) **Pub. No.: US 2012/0118736 A1**  
(43) **Pub. Date: May 17, 2012**

(54) **LIQUID DIELECTROPHORETIC DEVICE  
AND METHOD FOR CONTROLLABLY  
TRANSPORTING A LIQUID USING THE  
SAME**

**Publication Classification**

(51) **Int. Cl.**  
*C25B 9/00* (2006.01)  
*C25B 15/00* (2006.01)  
(52) **U.S. Cl.** ..... **204/451; 204/601**

(75) **Inventors:** **Shih-Kang Fan**, Hsinchu (TW);  
**I-Pei Lu**, Hsinchu (TW)

(57) **ABSTRACT**

(73) **Assignee:** **NATIONAL CHIAO TUNG  
UNIVERSITY**, Hsinchu (TW)

A liquid dielectrophoretic device comprises: a first container unit defining a first micro containing space including an electrode pair for generating a dielectrophoretic force; a second container unit defining a second micro containing space and including an electrode pair for generating a dielectrophoretic force; and a fluid channel unit defining a micro-channel between the first and second micro containing spaces and including an electrode pair having a middle region layer that has first and second enlarged sections and a middle section disposed between the first and second enlarged sections. The first and second enlarged sections are enlarged gradually from the middle section to the first and second micro containing spaces. A method for controllably transporting a liquid using the liquid dielectrophoretic device is also disclosed.

(21) **Appl. No.:** **13/179,253**

(22) **Filed:** **Jul. 8, 2011**

(30) **Foreign Application Priority Data**

Nov. 15, 2010 (TW) ..... 099139192

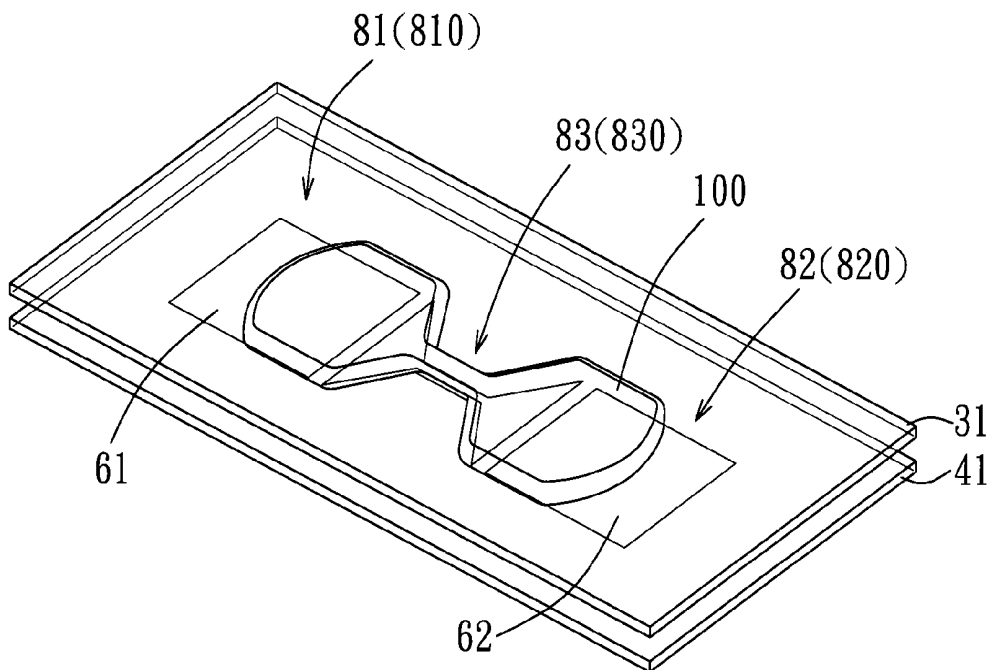

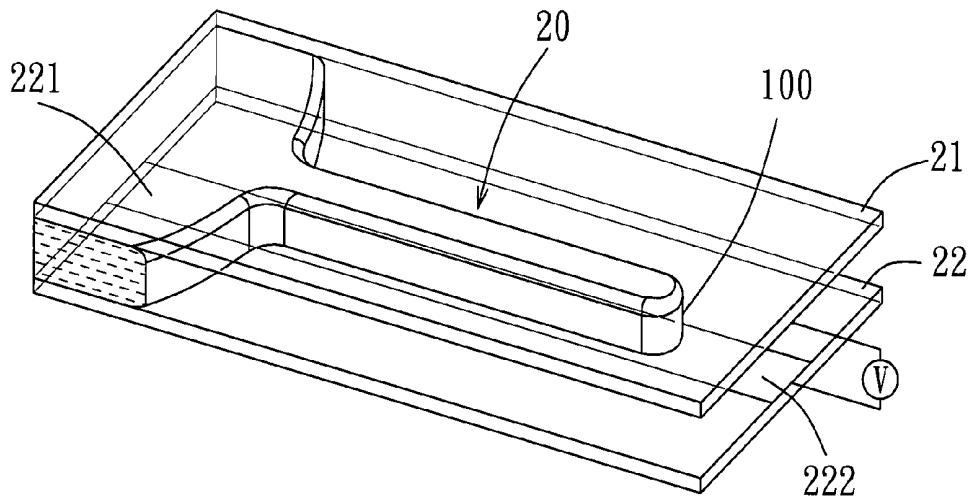

FIG. 1  
PRIOR ART

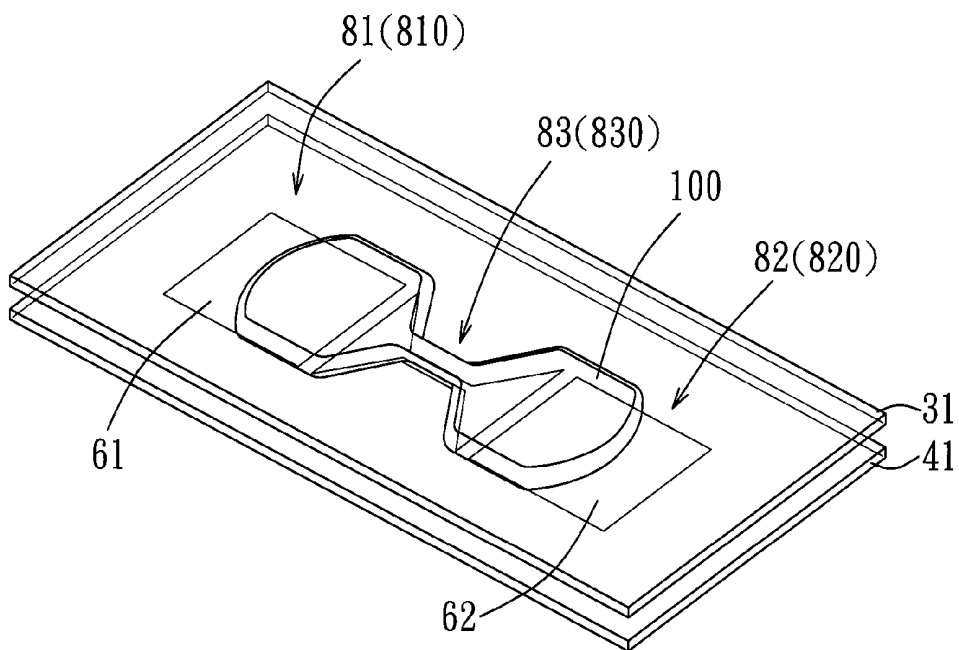

FIG. 2

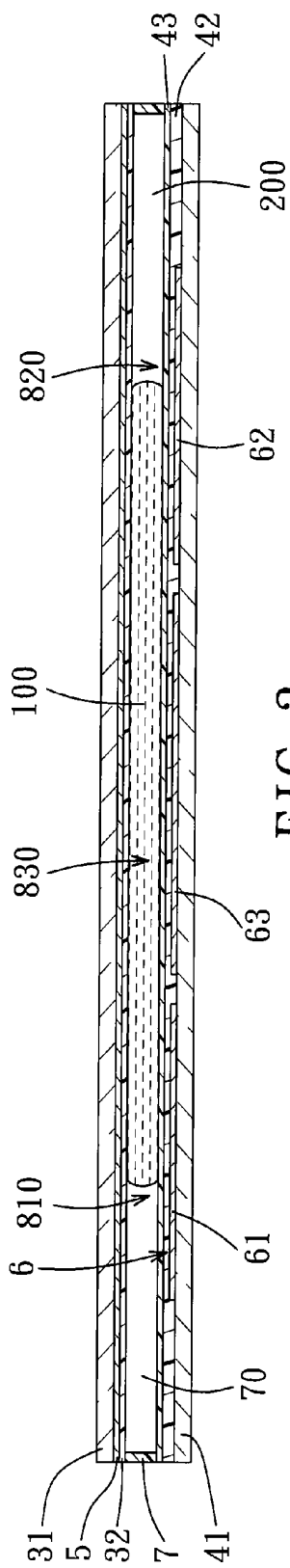

FIG. 3

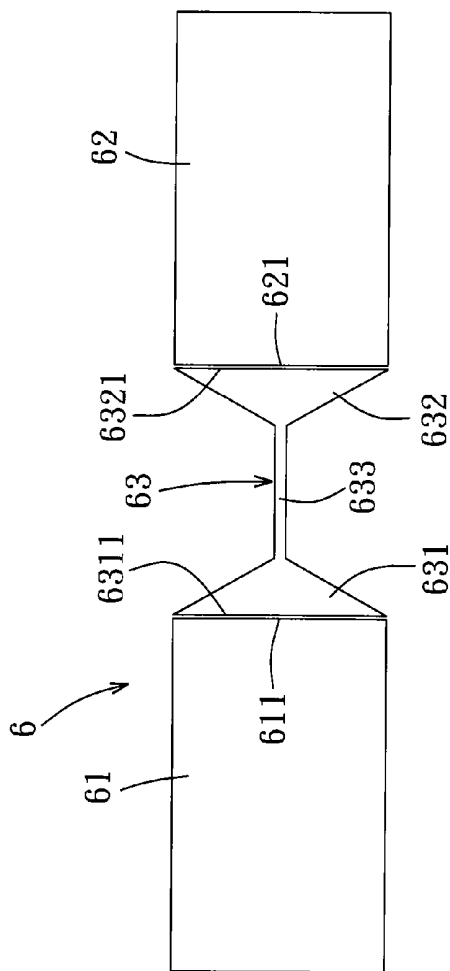

FIG. 4

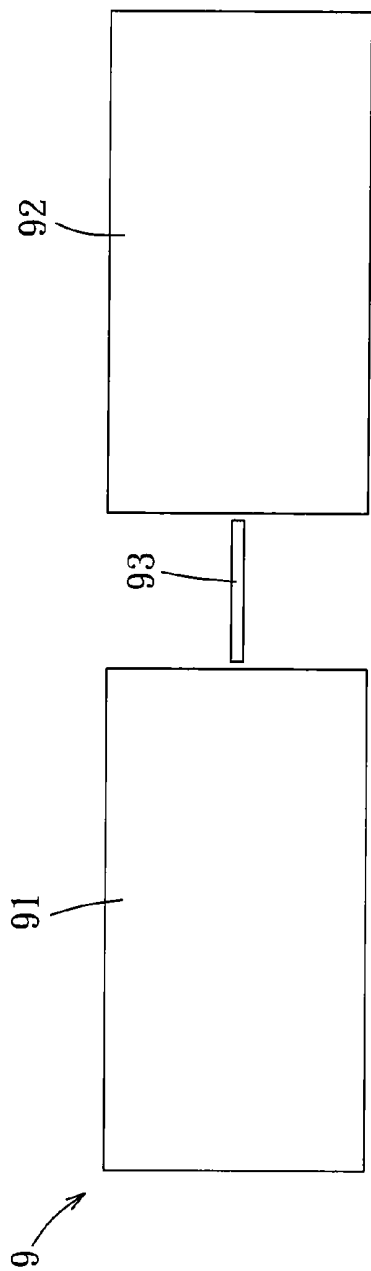

FIG. 5

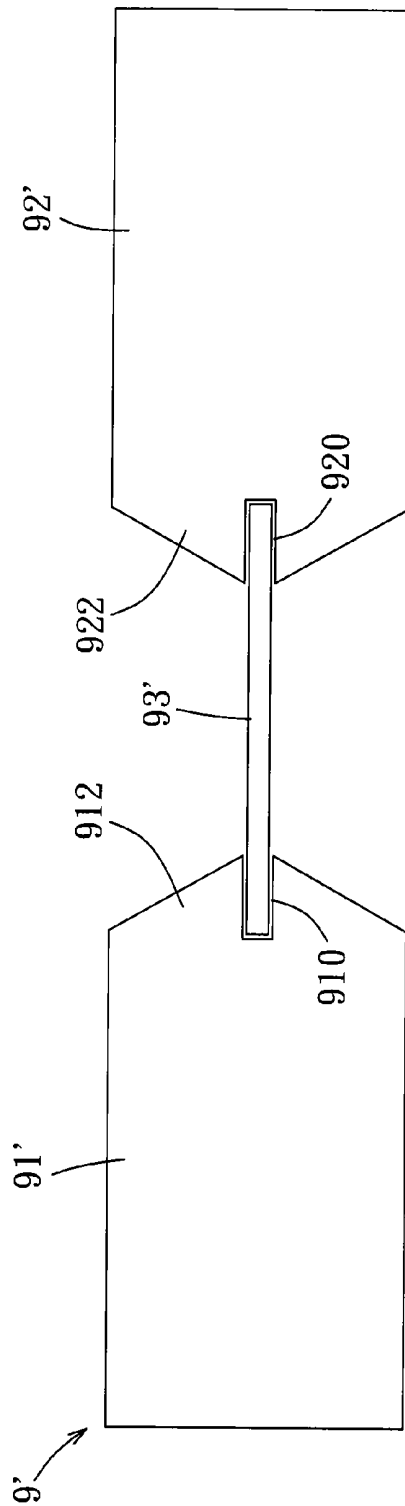

FIG. 6

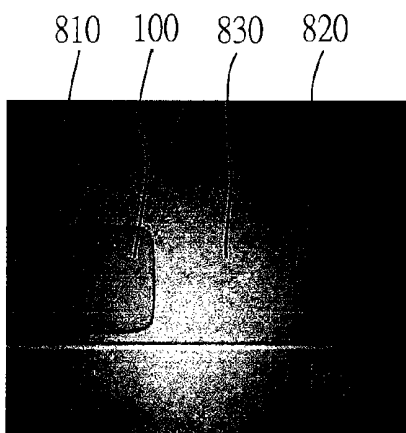

FIG. 7A

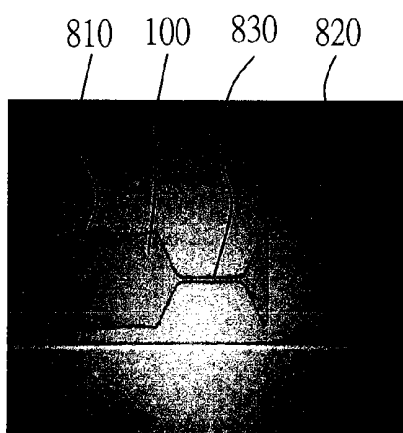

FIG. 7B

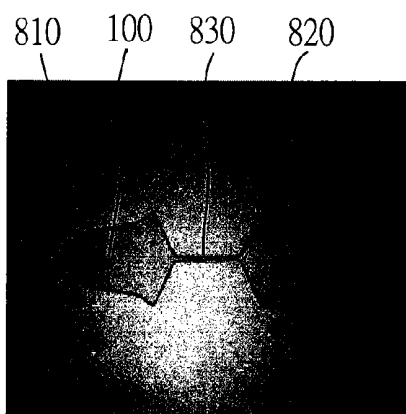

FIG. 7C

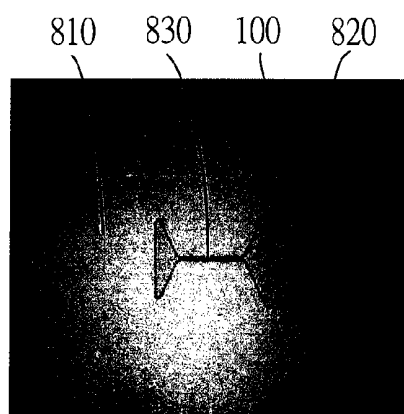

FIG. 7D

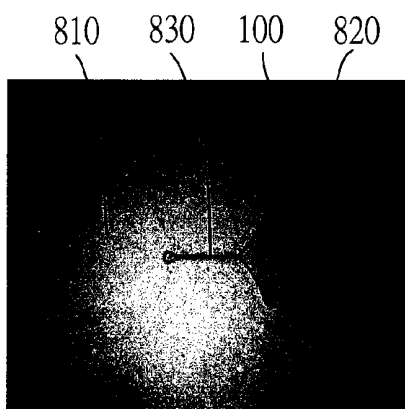

FIG. 7E

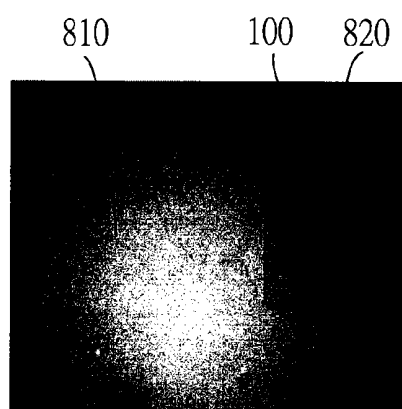

FIG. 7F

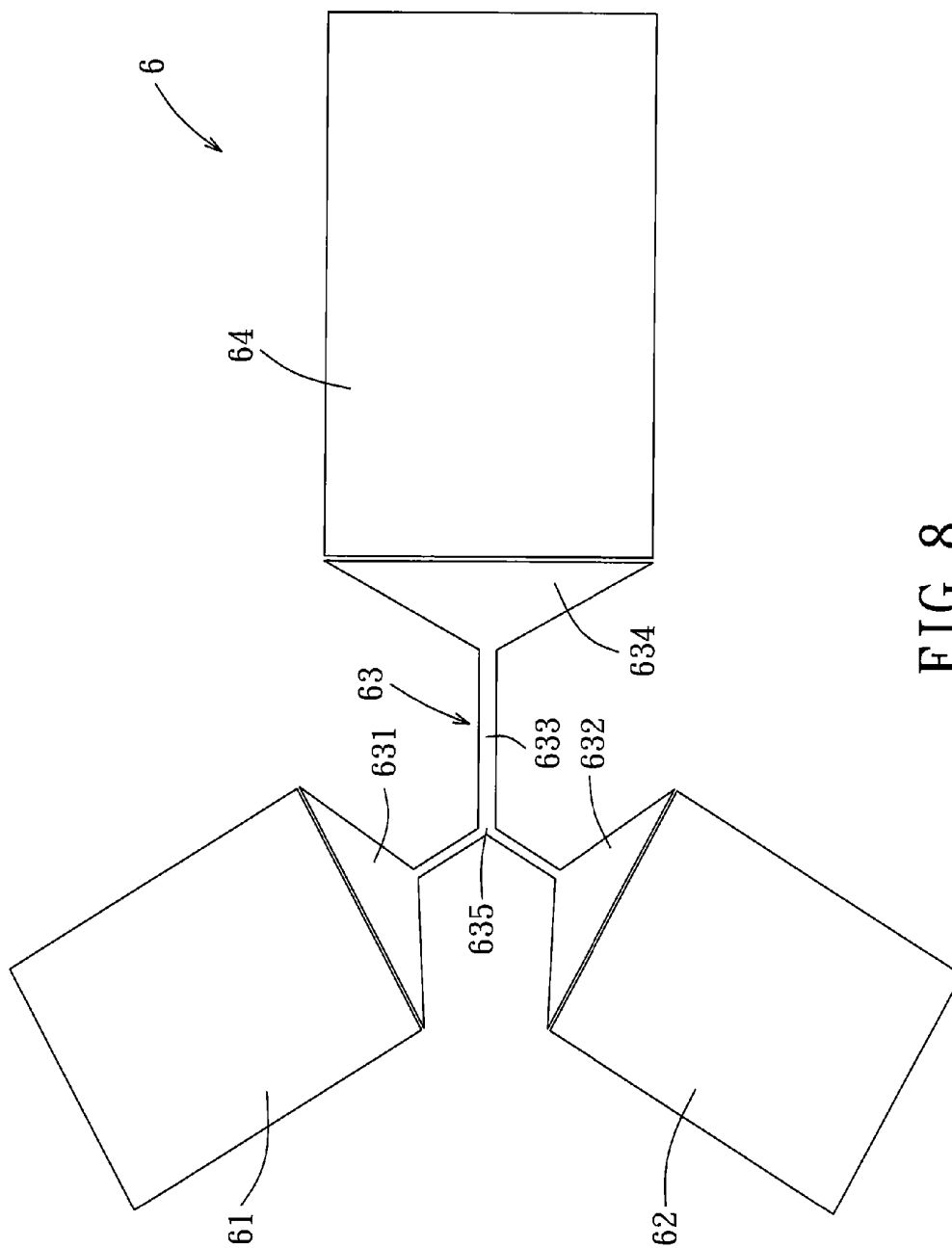

FIG. 8

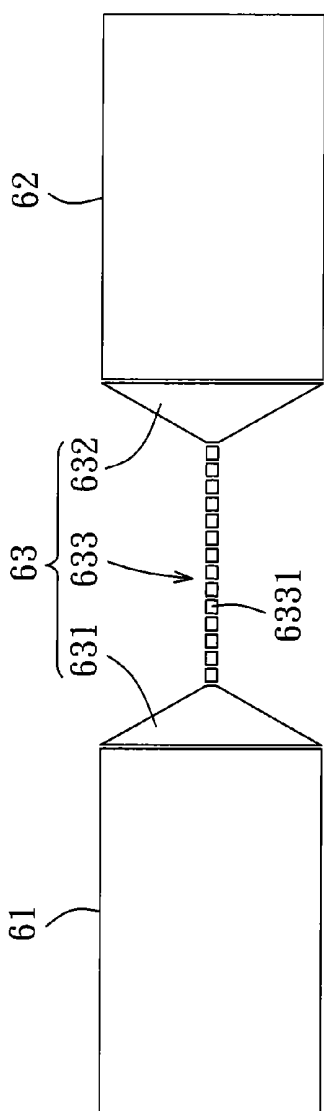

FIG. 9

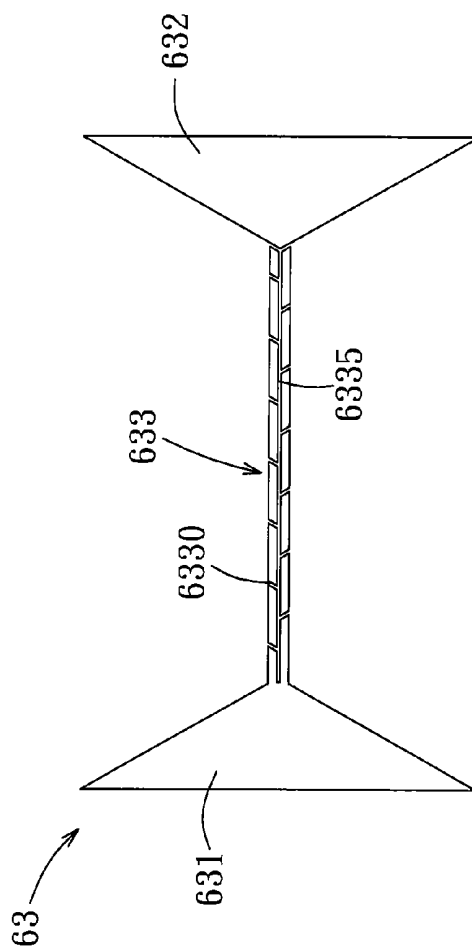

FIG. 10

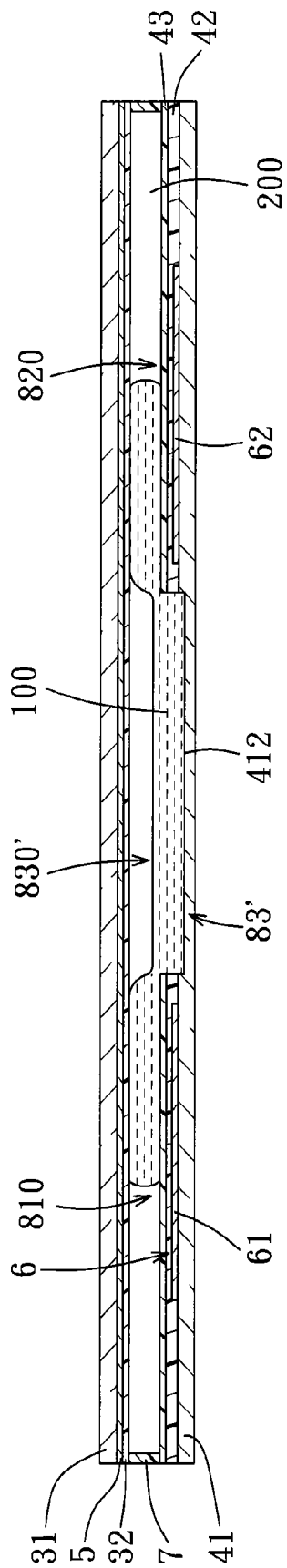

FIG. 11



**LIQUID DIELECTROPHORETIC DEVICE  
AND METHOD FOR CONTROLLABLY  
TRANSPORTING A LIQUID USING THE  
SAME**

CROSS-REFERENCE TO RELATED  
APPLICATION

[0001] This application claims priority of Taiwanese Patent Application No. 099139192 filed on Nov. 15, 2010.

BACKGROUND OF THE INVENTION

[0002] 1. Field of the Invention

[0003] The invention relates to a liquid dielectrophoretic device and a method for controllably transporting a liquid using the liquid dielectrophoretic device.

[0004] 2. Description of the Related Art

[0005] Microfluidic systems or microfluidic chips have been utilized widely in the biotechnological field, the pharmaceutical field, electro optical field, etc., due to their high responsiveness, high sensitivity, high reproducibility, low cost, and low pollution. Microfluidic systems can drive fluids in a mechanical manner or an electrokinetic manner. The electrokinetic manner can be performed through dielectrophoresis or electro-osmosis.

[0006] Fan et al. "Reconfigurable liquid pumping in electric-field-defined virtual microchannel by dielectrophoresis", Lab Chip, pp. 1590-1595, vol. 9, 2009, disclose a conventional liquid dielectrophoretic device (see FIG. 1). The liquid dielectrophoretic device includes upper and lower electrode plates 21 22 that cooperate to define a virtual micro channel 20 for receiving a liquid 100 (the boundary of the liquid 100 in the micro channel 20 is not confined and limited by a real wall but by an electric field in the micro channel 20). The boundary of the liquid 100 in the micro channel 20 is defined by the shape of the lower electrode plate 22. The lower electrode plate 22 has opposite first and second end portions 221, 222. When the liquid 100 is disposed on the first end portion 221 of the lower electrode 22 and when an electric field is formed in the micro channel 20, a dielectrophoretic force is generated to drive flow of the liquid 100 disposed on the first end portion 221 to the second end portion 222. However, the conventional liquid dielectrophoretic device is insufficient to effectively control the flow rate of the liquid.

SUMMARY OF THE INVENTION

[0007] The object of the present invention is to provide a liquid dielectrophoretic device that can effectively control the flow rate of a liquid in the liquid dielectrophoretic device.

[0008] According to one aspect of the present invention, there is provided a liquid dielectrophoretic device that comprises: a first container unit defining a first micro containing space for containing a liquid therein and including an electrode pair for generating a dielectrophoretic force acting on the liquid in the first micro containing space by forming an electric field in the first micro containing space, the electrode pair having a first region layer; a second container unit defining a second micro containing space for containing the liquid therein and including an electrode pair for generating a dielectrophoretic force acting on the liquid in the second micro containing space by forming an electric field in the second micro containing space, the electrode pair of the second containing unit having a second region layer; and a fluid channel unit defining a micro-channel and including an elec-

trode pair for forming an electric field in the micro-channel. The electrode pair of the fluid channel unit has a middle region layer that has first and second enlarged sections and a middle section disposed between the first and second enlarged sections. The first enlarged section is disposed between the first region layer and one end of the middle section and is enlarged in width from one end thereof that is distal from the first region layer to the other end thereof that is proximate to the first region layer. The second enlarged section is disposed between the second region layer and the other end of the middle section and is enlarged in width from one end thereof that is distal from the second region layer to the other end thereof that is proximate to the second region layer. The liquid in one of the first and second micro containing spaces can be controllably transported to the other of the first and second micro containing spaces through the micro-channel by varying the difference between the electric field in said one of the first and second micro containing spaces and the electric field in the other of the first and second micro containing spaces.

[0009] According to another aspect of the present invention, there is provided a liquid dielectrophoretic device that comprises: a first container unit defining a first micro containing space for containing a liquid therein and including an electrode pair for generating a dielectrophoretic force acting on the liquid in the first micro containing space by forming an electric field in the first micro containing space, the electrode pair having a first region layer; a second container unit defining a second micro containing space for containing the liquid therein and including an electrode pair for generating a dielectrophoretic force acting on the liquid in the second micro containing space by forming an electric field in the second micro containing space, the electrode pair of the second containing unit having a second region layer; and a fluid channel unit defining a micro-channel between the first and second region layers of the first and second container units, and including first and second enlarged sections proximate to the first and second region layers, respectively, and a middle section connected between the first and second enlarged sections, the first and second enlarged sections being enlarged gradually from the middle section to the first and second region layers, respectively. Preferably, the first and second enlarged sections respectively have largest widths that are adjacent to and substantially as large as those of the first and second region layers of the first and second container units, respectively.

[0010] In an embodiment, the fluid channel unit further includes an electrode pair for forming an electric field in the micro-channel. The electrode pair of the fluid channel unit has a middle region layer disposed between the first and second region layers. The middle region layer defines the micro-channel and has the middle section and the first and second enlarged sections.

[0011] In another embodiment, the fluid channel unit further includes a capillary that defines the micro-channel and that has the first and second enlarged sections and the middle section. The first and second enlarged sections of the capillary are in spatial communication with the first and second micro containing spaces, respectively.

[0012] According to still another aspect of the invention, there is provided a method for controllably transporting a liquid using a liquid dielectrophoretic device that includes a first and second container units and a fluid channel unit, the first container unit defining a first micro containing space and

including an electrode pair, the second container unit defining a second micro containing space and including an electrode pair, the first micro containing space being in fluid communication with the second micro containing space via the fluid channel unit. The method comprises:

[0013] forming a continuous phase of a liquid in the fluid channel unit and the first and second micro containing spaces;

[0014] applying a first voltage to the electrode pair of the first container unit to generate a dielectrophoretic force acting on the liquid in the first micro containing space by forming an electric field in the first micro containing space;

[0015] applying a second voltage to the electrode pair of the second container unit so as to generate a dielectrophoretic force acting on the liquid in the second micro containing space by forming an electric field in the second micro containing space; and

[0016] varying the difference between the respective electric fields in the first and second micro containing spaces to regulate a flow rate of the liquid between the first and second micro containing spaces.

#### BRIEF DESCRIPTION OF THE DRAWINGS

[0017] In drawings which illustrate embodiments of the invention,

[0018] FIG. 1 is a perspective view of a conventional liquid dielectrophoretic device;

[0019] FIG. 2 is a perspective view of the first preferred embodiment of a liquid dielectrophoretic device according to this invention;

[0020] FIG. 3 is a sectional view of the first preferred embodiment;

[0021] FIG. 4 is a schematic top view of a lower electrode layer of the first preferred embodiment;

[0022] FIG. 5 is a schematic top view of a lower electrode layer of a liquid dielectrophoretic device of Comparative Example 1;

[0023] FIG. 6 is a schematic top view of a lower electrode layer of a liquid dielectrophoretic device of Comparative Example 2;

[0024] FIGS. 7A-7F are photo images illustrating how a liquid is transported by dielectrophoresis from a first micro containing space to a second micro containing space via a micro channel;

[0025] FIG. 8 is a schematic top view of the second preferred embodiment of a liquid dielectrophoretic device according to this invention, illustrating the structure of a lower electrode layer;

[0026] FIG. 9 is a schematic top view of the third preferred embodiment of a liquid dielectrophoretic device according to this invention, illustrating the structure of a lower electrode layer;

[0027] FIG. 10 is a schematic top view of the fourth preferred embodiment of a liquid dielectrophoretic device according to this invention, illustrating the structure of a lower electrode layer; and

[0028] FIG. 11 is a sectional view of the fifth preferred embodiment of a liquid dielectrophoretic device according to this invention.

#### DETAILED DESCRIPTION OF THE PREFERRED EMBODIMENTS

[0029] FIGS. 2 to 4 illustrate the first preferred embodiment of a liquid dielectrophoretic device for transporting a liquid

100 therein. The liquid dielectrophoretic device includes an upper substrate 31, an upper electrode layer 5 formed on the upper substrate 31, an upper hydrophobic layer formed on the upper electrode layer 5, a lower substrate 41 opposite to the upper substrate 31, a lower electrode layer 6 formed on the lower substrate 41, a dielectric layer 42 formed on the lower substrate 41 and the lower electrode layer 6 to cover entirely the lower electrode layer 6, a lower hydrophobic layer 43 formed on the dielectric layer 42, and a spacer 7 disposed between and cooperating with the upper and lower hydrophobic layers 32, 43 to define an accommodating space 70 thereamong.

[0030] The upper electrode layer 5 is not patterned. The lower electrode layer 6 is patterned and includes first and second region layers 61, 62 opposite to each other, and a middle region layer 63 disposed between and spaced apart from the first and second region layers 61, 62. In this embodiment, each of the first and second region layers 61, 62 is rectangular (2500  $\mu\text{m}$   $\times$  2000  $\mu\text{m}$ ) in shape, and the middle region layer 63 has a dumbbell-like shape. The first region layer 61 cooperates with the upper electrode layer 5 to define a first container unit 81 in the accommodating space 70. The second region layer 62 cooperates with the upper electrode layer 5 to define a second container unit 82 in the accommodating space 70. The middle region layer 63 cooperates with the upper electrode layer 5 to define a fluid channel unit 83 in the accommodating space 70. It is noted that variations of the structure of the liquid dielectrophoretic device can be made based on the actual requirements in different applications. For instance, in other applications, the upper electrode layer 5 may have a pattern of a plurality of spaced apart conductors, the upper and lower hydrophobic layers 32, 43 or the dielectric layer 42 may be dispensed with, or the liquid dielectrophoretic device may further include an upper dielectric layer interposed between the upper electrode layer 5 and the upper hydrophobic layer 32.

[0031] The first container unit 81 defines a first micro containing space 810 for containing the liquid 100 therein, and includes an electrode pair defined by the first region layer 61 and the upper electrode 5 for generating a dielectrophoretic force acting on the liquid 100 in the first micro containing space 810 by forming an electric field in the first micro containing space 810. It is noted that another fluid 200, such as air or silicone oil, is also received in the accommodating space to surround the liquid 100. The first region layer 61 of the lower electrode layer 6 defines the boundary of the electric field generated thereby, which, in turn, defines the boundary or the shape of the first micro containing space 810.

[0032] The second container unit 82 defines a second micro containing space 820 for containing the liquid 100 therein, and includes an electrode pair defined by the second region layer 62 and the upper electrode 5 for generating a dielectrophoretic force acting on the liquid 100 in the second micro containing space 820 by forming an electric field in the second micro containing space 820. The second region layer 62 of the lower electrode layer 6 defines the boundary of the electric field generated thereby, which, in turn, defines the boundary or the shape of the second micro containing space 820.

[0033] The fluid channel unit 83 defines a micro-channel 830, and includes an electrode pair defined by the middle region layer 63 and the upper electrode 5 for forming an electric field in the micro-channel 830. The middle region layer 63 of the lower electrode layer 6 defines the boundary of

the electric field generated thereby, which, in turn, defines the boundary or the shape of the micro-channel **830**. The middle region layer **63** has first and second enlarged sections **631**, **632** and a middle section **633** (having a width of 100  $\mu\text{m}$ .) disposed between the first and second enlarged sections **631**, **632**. The first enlarged section **631** is disposed between the first region layer **61** and one end of the middle section **633** and is enlarged in width from one end thereof that is distal from the first region layer **61** to the other end **6311** thereof that is proximate to the first region layer **61**. The second enlarged section **632** is disposed between the second region layer **62** and the other end of the middle section **633** and is enlarged in width from one end thereof that is distal from the second region layer **62** to the other end **6321** thereof that is proximate to the second region layer **62**.

[0034] Since the dielectrophoretic forces acting on the liquid **100** in the first micro containing space **810** and on the liquid **100** in the second micro containing space **820** are opposite to each other, the higher the difference between the dielectrophoretic forces, the higher the driving force to drive the liquid **100** to flow from one of the first and second micro containing spaces **810**, **820** to the other of the first and second micro containing spaces **810**, **820**. Hence, by varying the difference between the electric field in one of the first and second micro containing spaces **810**, **820** and the electric field in the other of the first and second micro containing spaces **810**, **820**, the flow rate of the liquid **100** from one of the first and second micro containing spaces **810**, **820** to the other of the first and second micro containing spaces **810**, **820** can be controlled.

[0035] In this embodiment, the first region layer **61** has an end **611** that is proximate to and spaced apart from the end **6311** of the first enlarged section **631** of the middle region layer **63** by a distance of 10  $\mu\text{m}$  and that has a width substantially the same as that of the end **6311** of the first enlarged section **631** of the middle region layer **63**. Similarly, the second region layer **62** has an end **621** that is proximate to and spaced apart from the end **6321** of the second enlarged section **632** of the middle region layer **63** by a distance of 10  $\mu\text{m}$  and that has a width substantially the same as that of the end **6321** of the second enlarged section **632** of the middle region layer **63**. The aforesaid distances can be varied based on the shapes and sizes of the middle region layer **63** and the first and second region layers **61**, **62**.

[0036] Preferably, the upper and lower substrates **31**, **41** are made of glass, and the upper and lower electrode layers **5**, **6** are made of indium tin oxide (ITO). The upper and lower hydrophobic layers **32**, **43** are preferably made of Teflon.

[0037] When the liquid **100** is to be transported from the first micro containing space **810** to the second micro containing space **820** using the preferred embodiment, the following consecutive steps are performed: injecting the liquid **100** into the first micro containing space **810**, forming a first electric field in the first micro containing space **810** by applying a voltage to the electrode pair of the first container unit **81** so as to confine the liquid **100** in the first micro containing space **810**, forming an electric field higher than the first electric field in the micro-channel **830** by applying a voltage to the electrode pair of the fluid channel unit **83** so as to drive the liquid **100** to flow into and to fill the micro-channel **830**, and forming a second electric field higher than the electric field in the first micro containing space **810** by applying a voltage to the electrode pair of the second container unit **82** so as to drive the liquid **100** to flow into the second micro containing space **820**.

It is noted that as soon as the liquid **100** flows from the micro-channel **830** into the second micro containing space **820**, the liquid **100** can be transported from the first micro containing space **810** to the second micro containing space **820** so long as the electric field in the second micro containing space **820** is higher than the electric field in the first micro containing space **810** no matter whether the input of the voltage to the electrode pair of the fluid channel unit **83** is stopped or continues.

[0038] Hence, a method for controllably transporting the liquid **100** using the liquid dielectrophoretic device can be provided. The method includes the steps of: forming a continuous phase of the liquid **100** in the fluid channel unit **83** and the first and second micro containing spaces **810**, **820**; applying a first voltage to the electrode pair of the first container unit **81** so as to generate a dielectrophoretic force acting on the liquid **100** in the first micro containing space **810** by forming an electric field in the first micro containing space **810**; applying a second voltage to the electrode pair of the second container unit **82** so as to generate a dielectrophoretic force acting on the liquid **100** in the second micro containing space **820** by forming an electric field in the second micro containing space **820**; and adjusting at least one of the voltages applied to the electrode pairs of the first and second container units **81**, **82** to vary the difference between the first and second electric fields to thereby adjust the difference between the dielectrophoretic forces acting on the liquid **100** in the first micro containing space **810** and the liquid **100** in the second micro containing space **820**, respectively, thereby permitting controlling of the flow rate of the liquid **100** from one of the first and second micro containing spaces **810**, **820** to the other of the first and second micro containing spaces **810**, **820** through the micro-channel **830**.

[0039] FIG. 5 illustrates the structure of a lower electrode layer **9** of Comparative Example 1 of a liquid dielectrophoretic device. The lower electrode layer **9** includes a first region layer **91**, a second region layer **92** and a middle region layer **93** disposed between the first and second region layers **91**, **92**. Comparative Example 1 differs from the first preferred embodiment in that the middle region layer **93** has a rectangular band-like shape. FIG. 6 illustrates the structure of a lower electrode layer **9'** of Comparative Example 2 of a liquid dielectrophoretic device. The lower electrode layer **9'** includes a first region layer **91'**, a second region layer **92'** and a middle region layer **93'** disposed between the first and second region layers **91'**, **92'**. Comparative Example 2 differs from the first preferred embodiment in that each of the first and second region layers **91'**, **92'** has one tapered end **912**, **922** formed with a recess **910**, **920** and that the middle region layer **93'** has a rectangular band-like shape and extends into the recesses **910**, **920**. Performance tests on the transportation of the liquid **100** for the liquid dielectrophoretic devices of Comparative Example 1 and 2 were conducted. Experimental results show that undesired breaking of the flow of the liquid **100** from one of the first and second region layers **91**, **92** (or **91'**, **92'**) to the other of the first and second region layers **91**, **92** (or **91'**, **92'**) occurs and the flow of the liquid **100** is interrupted.

[0040] As compared to Comparative Examples 1 and 2, the performance test on the transportation of the liquid **100** for the first preferred embodiment (see FIGS. 7A to 7F) shows that the liquid **100** can flow smoothly from one of the first and second micro containing spaces **810**, **820** to the other of the

first and second micro containing spaces **810**, **820** through the micro-channel **830** and that no breaking of the flow of the liquid **100** occurs.

[0041] FIG. 8 illustrates the second preferred embodiment of the liquid dielectrophoretic device according to the present invention. The second preferred embodiment differs from the previous embodiment as follows:

[0042] The lower electrode layer **6** additionally has a third region layer **64** that cooperates with the upper electrode layer **5** (FIG. 3) to form an electrode pair for generating a dielectrophoretic force in a third container unit (not shown) that has a third micro containing space (not shown) in the accommodating space **70** (FIG. 3). The middle region layer **63** further includes a third enlarged section **634** proximate to the third region layer **64**. The middle section **633** of the middle region layer **63** is formed as a Y-shaped structure, and has three ends connected respectively to the first, second and third enlarged sections **631**, **632**, **634**, respectively.

[0043] The second preferred embodiment can be used to mix two different liquids. When two different liquids (not shown) are to be mixed, the liquids are loaded at the first and second region layers **61**, **62**, respectively, followed by applying different voltages to the middle region layer **63** and the first, second and third region layers **61**, **62**, **63** so as to drive the liquids at the first and second region layers **61**, **62** to flow to the third region layer **64** and to permit the liquids to mix together at an intersection **635** of the middle section **633** of the middle region layer **63**.

[0044] FIG. 9 illustrates the third preferred embodiment of the liquid dielectrophoretic device according to the present invention. The third preferred embodiment differs from the first preferred embodiment in that the middle section **633** of the middle region layer **63** of the lower electrode layer **6** includes a plurality of conductors **6331** spaced apart from each other and aligned along the length thereof. Two endmost ones of the conductors **6331** are spaced apart from the first and second enlarged sections **631**, **632**.

[0045] FIG. 10 illustrates the fourth preferred embodiment of the liquid dielectrophoretic device according to the present invention. The fourth preferred embodiment differs from the first preferred embodiment in that the middle section **633** of the middle region layer **63** of the lower electrode layer **6** is formed with a central passage **6335** extending along the length thereof and has two opposite sides, each of which is formed with a plurality of notches **6330** that are aligned along the length thereof and that are in fluid communication with the central passage **6335**. The fourth preferred embodiment can be used to collect particles at the notches **6330** and the central passage **6335** when the liquid **100** carrying the particles passes through the middle section **633** of the middle region layer **63**. The upper and lower hydrophobic layers **32**, **43** and the dielectric layer **42** are not provided in this embodiment.

[0046] FIG. 11 illustrates the fifth preferred embodiment of the liquid dielectrophoretic device according to the present invention. The fifth preferred embodiment differs from the first preferred embodiment in that in the fifth preferred embodiment, the lower electrode layer **6** has no middle region layer **63**, and a capillary **412** is formed in the lower hydrophobic layer **43**, the dielectric layer **42**, the lower electrode layer **6** and the lower substrate **41**. The capillary **412** defines the micro-channel **830'** of the fluid channel unit **83'**, which has two ends in spatial communication with the first and second micro containing spaces **810**, **820**, respectively. The capillary

**412** may be configured to have a middle section and two enlarged sections like the middle region layer **63** of the first preferred embodiment. Alternatively, the capillary **412** may be configured to have a constant width throughout its length. The liquid **100** is permitted to flow from one of the first and second micro containing spaces **810**, **820** to the other of the first and second micro containing spaces **810**, **820** through the capillary **412** by dielectrophoresis.

[0047] By designing the middle region layer **63** of the lower electrode layer **6** to have the dumbbell-like shape, the liquid dielectrophoretic device of this invention can overcome the undesired breaking of the flow of the liquid as encountered in Comparative Examples 1 and 2. In addition, by varying the difference between the electric fields in the first and second micro containing spaces **810**, **820**, the flow rate of the liquid **100** from one of the first and second micro containing spaces **810**, **820** to the other of the first and second micro containing spaces **810**, **820** can be controlled.

[0048] While the present invention has been described in connection with what are considered the most practical and preferred embodiments, it is understood that this invention is not limited to the disclosed embodiments but is intended to cover various arrangements included within the spirit and scope of the broadest interpretation so as to encompass all such modifications and equivalent arrangements.

What is claimed is:

1. A liquid dielectrophoretic device comprising:

- a first container unit defining a first micro containing space for containing a liquid therein and including an electrode pair for generating a dielectrophoretic force acting on the liquid in said first micro containing space by forming an electric field in said first micro containing space, said electrode pair having a first region layer;
- a second container unit defining a second micro containing space for containing the liquid therein and including an electrode pair for generating a dielectrophoretic force acting on the liquid in said second micro containing space by forming an electric field in said second micro containing space, said electrode pair of said second containing unit having a second region layer; and
- a fluid channel unit defining a micro-channel and including an electrode pair for forming an electric field in said micro-channel, said electrode pair of said fluid channel unit having a middle region layer that has first and second enlarged sections and a middle section disposed between said first and second enlarged sections, said first enlarged section being disposed between said first region layer and one end of said middle section and being enlarged in width from one end thereof that is distal from said first region layer to the other end thereof that is proximate to said first region layer, said second enlarged section being disposed between said second region layer and the other end of said middle section and being enlarged in width from one end thereof that is distal from said second region layer to the other end thereof that is proximate to said second region layer;

whereby the liquid in one of said first and second micro containing spaces can be controllably transported to the other of said first and second micro containing spaces through said micro-channel by varying the difference between the electric field in said one of said first and second micro containing spaces and the electric field in the other of said first and second micro containing spaces.

2. The liquid dielectrophoretic device of claim 1, wherein said first region layer has an end having a width substantially the same as that of the adjacent end of said first enlarged section of said middle region layer.

3. The liquid dielectrophoretic device of claim 1, wherein said second region layer has an end having a width substantially the same as that of the adjacent end of said second enlarged section of said middle region layer.

4. The liquid dielectrophoretic device of claim 1, wherein said middle section of said middle region layer of said electrode pair of said fluid channel unit has one side formed with a plurality of notches that are aligned along the length thereof.

5. The liquid dielectrophoretic device of claim 1, wherein said middle section of said middle region layer of said electrode pair of said fluid channel unit includes a plurality of spaced apart conductors that are aligned along the length thereof.

6. A liquid dielectrophoretic device comprising:

a first container unit defining a first micro containing space for containing a liquid therein and including an electrode pair for generating a dielectrophoretic force acting on the liquid in said first micro containing space by forming an electric field in said first micro containing space, said electrode pair having a first region layer;

a second container unit defining a second micro containing space for containing the liquid therein and including an electrode pair for generating a dielectrophoretic force acting on the liquid in said second micro containing space by forming an electric field in said second micro containing space, said electrode pair of said second containing unit having a second region layer; and

a fluid channel unit defining a micro-channel between said first and second region layers of said first and second micro containing units, and including at least first and second enlarged sections proximate to said first and second region layers, respectively, and a middle section connected between said first and second enlarged sections, said first and second enlarged sections being gradually enlarged in width from said middle section to said first and second region layers, respectively.

7. The liquid dielectrophoretic device of claim 6, wherein said fluid channel unit further includes an electrode pair for forming an electric field in said micro-channel, said electrode pair of said fluid channel unit having a middle region layer disposed between said first and second region layers, said middle region layer defining said micro-channel and having said middle section and said first and second enlarged sections.

8. The liquid dielectrophoretic device of claim 6, wherein said fluid channel unit further includes a capillary that defines said micro-channel and that has said first and second enlarged sections and said middle section, said first and second enlarged sections of said capillary being in spatial communication with said first and second micro containing spaces, respectively.

9. The liquid dielectrophoretic device of claim 6, wherein said first and second enlarged sections respectively have largest widths that are adjacent to and substantially as large as those of said first and second region layers of said first and second container units, respectively.

10. The liquid dielectrophoretic device of claim 7, further comprising a third container unit defining a third micro containing space and including an electrode pair for generating a dielectrophoretic force in said third micro containing space, said electrode pair of said third container unit having a third region layer, said middle region layer of said fluid channel unit further including a third enlarged section proximate to said third region layer, said middle section of said said middle region layer being formed as a Y-shaped structure, and having three ends connected respectively to said first, second and third enlarged sections.

11. A method for controllably transporting a liquid using a liquid dielectrophoretic device that includes first and second container units and a fluid channel unit, the first container unit defining a first micro containing space and including an electrode pair, the second container unit defining a second micro containing space and including an electrode pair, the first micro containing space being in fluid communication with the second micro containing space via the fluid channel unit, the method comprising:

forming a continuous phase of a liquid in the fluid channel unit and the first and second micro containing spaces;

applying a first voltage to the electrode pair of the first container unit to generate a dielectrophoretic force acting on the liquid in the first micro containing space by forming an electric field in the first micro containing space;

applying a second voltage to the electrode pair of the second container unit so as to generate a dielectrophoretic force acting on the liquid in second micro containing space by forming an electric field in the second micro containing space; and

varying the difference between the respective electric fields in the first and second micro containing spaces to regulate a flow rate of the liquid between the first and second micro containing spaces.

\* \* \* \* \*