



US 20110042782A1

(19) **United States**

(12) **Patent Application Publication**  
**CHAO et al.**

(10) **Pub. No.: US 2011/0042782 A1**

(43) **Pub. Date: Feb. 24, 2011**

(54) **ON-CHIP INDUCTOR STRUCTURE AND METHOD FOR MANUFACTURING THE SAME**

(30) **Foreign Application Priority Data**

Aug. 21, 2009 (TW) ..... 098128200

(75) Inventors: **TZU-YUAN CHAO**, TAOYUAN COUNTY 330 (TW); **MING-CHIEH HSU**, TAIPEI COUNTY 236 (TW); **YU-TING CHENG**, HSINCHU CITY 300 (TW); **CHIH CHEN**, HSINCHU 300 (TW); **CHIEN-MIN LIU**, TAICHUNG COUNTY 434 (TW)

**Publication Classification**

(51) **Int. Cl.**  
*H01L 29/86* (2006.01)  
*H01L 21/02* (2006.01)  
(52) **U.S. Cl. .... 257/531**; 438/381; 438/3; 257/E29.325; 257/E21.022; 977/755

(57) **ABSTRACT**

The present invention relates to an on-chip inductor structure and a method for manufacturing the same. The on-chip inductor structure according to the present invention comprises a substrate, a porous layer, a plurality of conductors, and an inductor. The porous layer is disposed on the substrate and has a plurality of voids; each of the plurality of conductors is disposed in the plurality of voids, respectively; and the inductor is disposed on the porous layer. Because the plurality of conductors is used as the core of the inductor, the inductance is increased effectively and the area of the on-chip inductor is reduced. Besides the manufacturing method according to the present invention is simple and compatible with the current CMOS process, the manufacturing cost can be lowered.

Correspondence Address:  
**ROSENBERG, KLEIN & LEE**  
**3458 ELLICOTT CENTER DRIVE-SUITE 101**  
**ELLICOTT CITY, MD 21043 (US)**

(73) Assignee: **NATIONAL CHIAO TUNG UNIVERSITY**, HSINCHU 300 (TW)

(21) Appl. No.: **12/607,433**

(22) Filed: **Oct. 28, 2009**

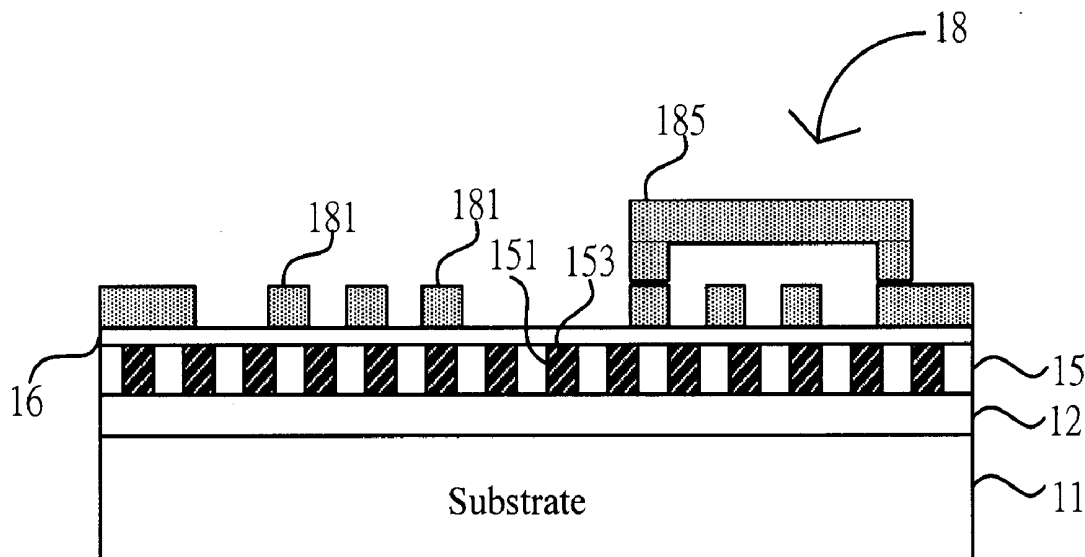

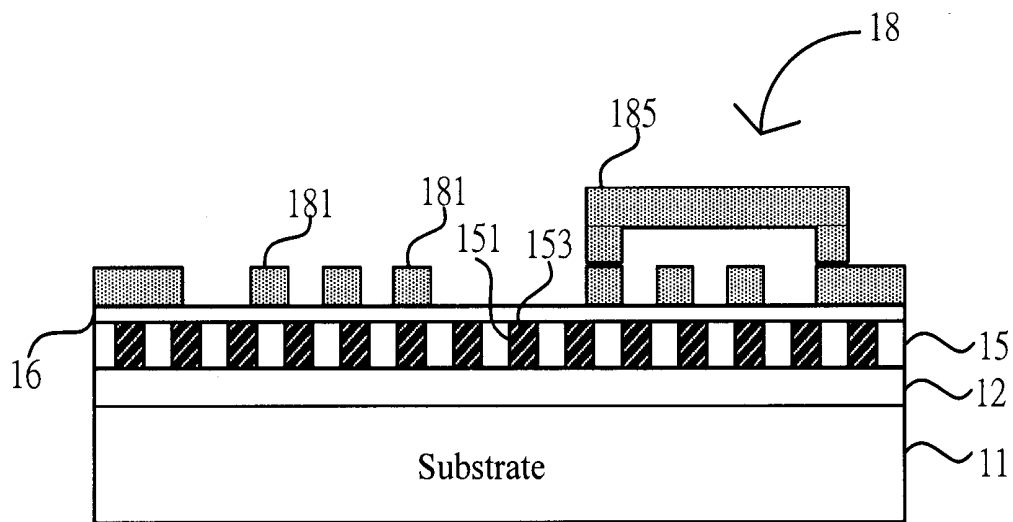

Figure 1

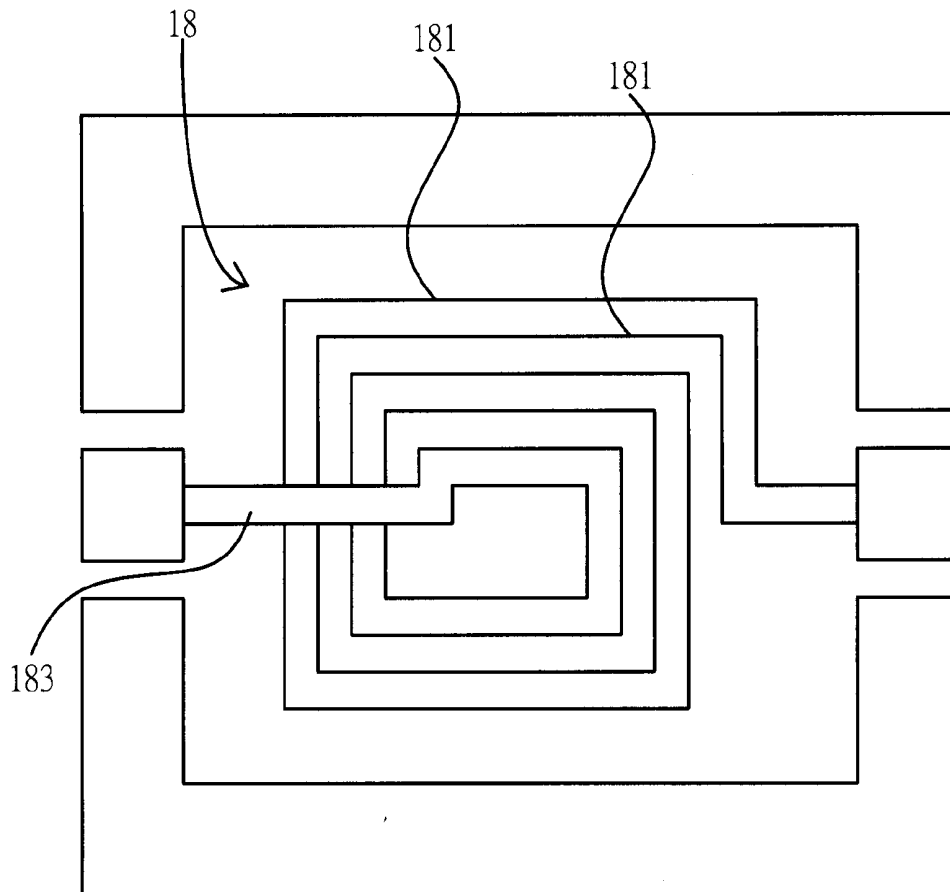

Figure 2

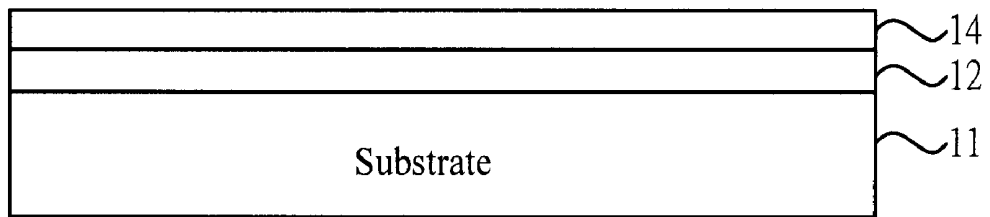

Figure 3A

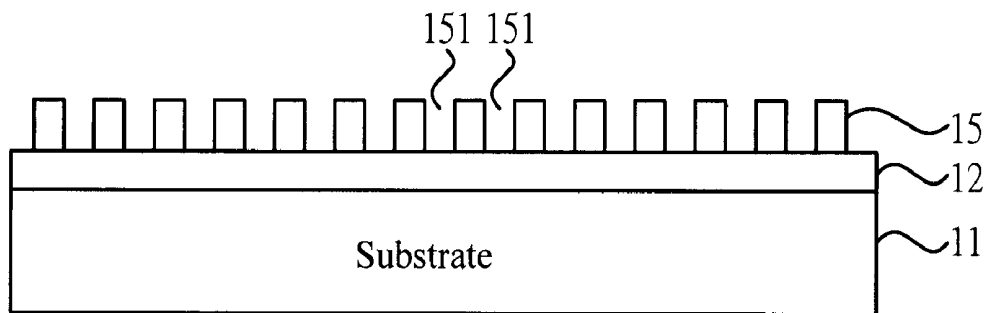

Figure 3B

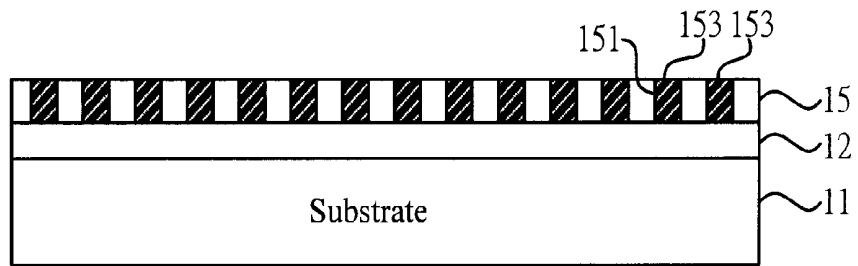

Figure 3C

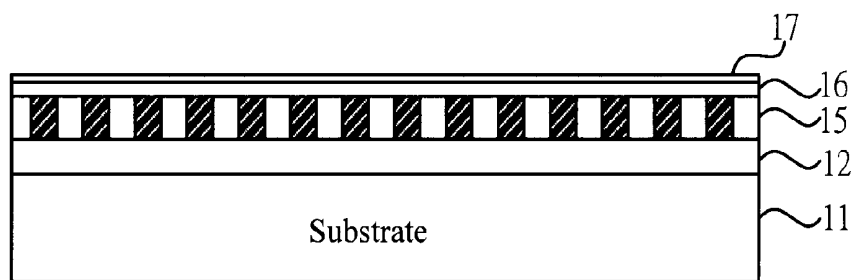

Figure 3D

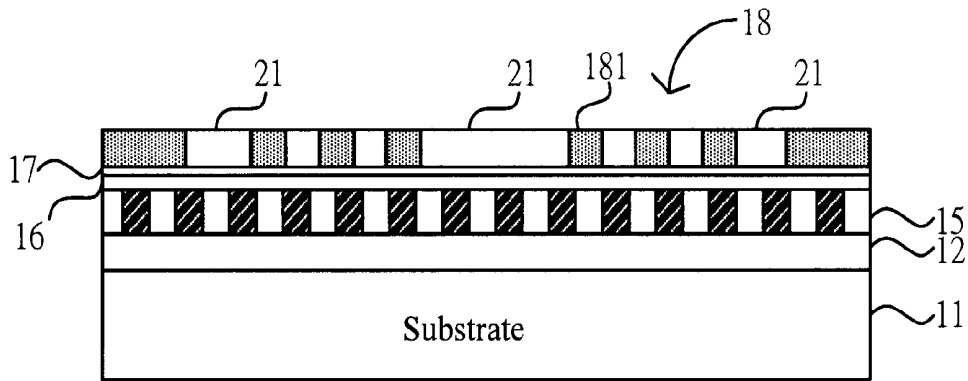

Figure 3E

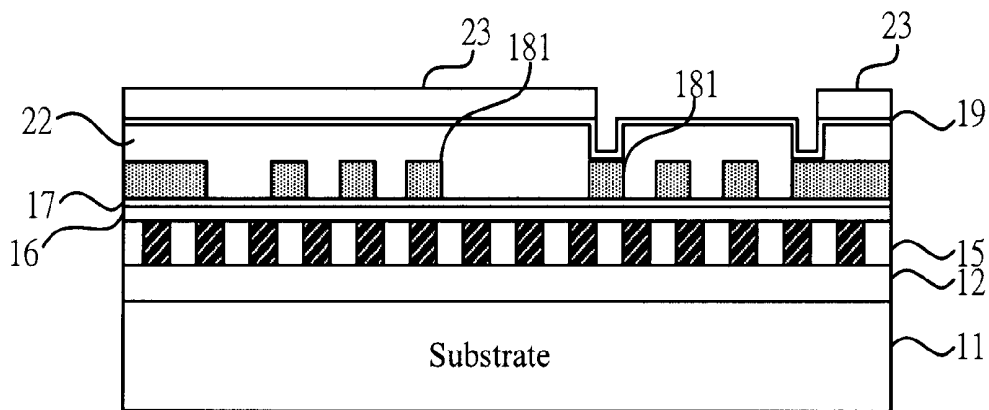

Figure 3F

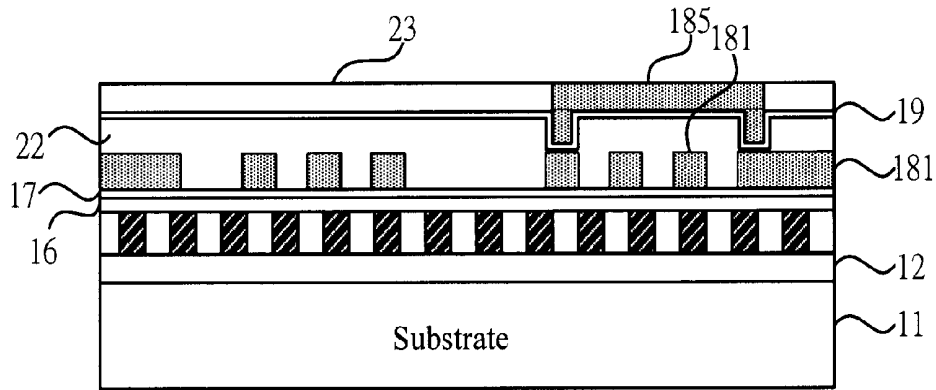

Figure 3G

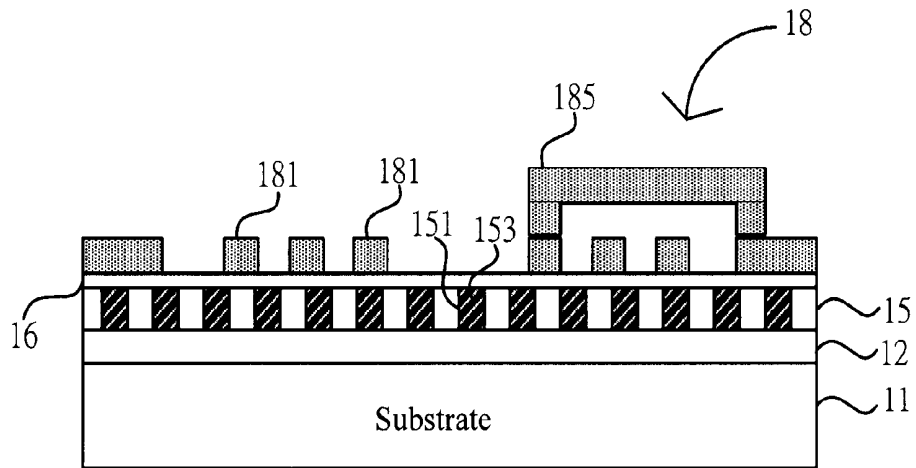

Figure 3H

## ON-CHIP INDUCTOR STRUCTURE AND METHOD FOR MANUFACTURING THE SAME

### FIELD OF THE INVENTION

[0001] The present invention relates to an inductor, and particularly to an on-chip inductor structure and a method for manufacturing the same.

### BACKGROUND OF THE INVENTION

[0002] With the progress of modern technologies, the coming of information era, and the prosperous development of network, various electronic products are developed for satisfying people's demand. The functions of the electronic products are becoming powerful and complete increasingly, and thus bringing convenience for people's lives. All of the current electronic products pursue miniaturization and are fastidious about lightness and thinness. Under high-density packaging, the size of the required electronic devices is becoming relatively smaller, particularly for radio-frequency integrated circuits (RFICs) applied in portable wireless communication electronic products.

[0003] Currently, for increasingly demanded RFICs, the most urgent need is not on enhancing the efficiency of active devices but on improving the characteristics of passive devices such as resistors, capacitors, and inductors. For modern semiconductor process technologies, it is not a problem to provide superior resistors and capacitors that are easy to be implemented and simulated. However, for passive inductors, the only choice is spiral inductors. The inductance of spiral inductors depends strongly on the semiconductor process adopted to fabricate them. The method for increasing the inductance of an on-chip inductor is mostly to increase the number of turns of the inductor, which will increase the occupied area, and hence is unfavorable for miniaturization of the on-chip inductor. Thereby, how to increase effectively the inductance is still a major issue for developing the on-chip inductor. In addition, the Q factor (quality factor) of the inductor will also reduce owing to substrate loss.

[0004] Accordingly, the present invention provides an on-chip inductor structure and a method for manufacturing the same for solving the problems described above. According to the present invention, the drawbacks according to the prior art as described above can be improved; the inductance can be increased; the area can be reduced; and the manufacturing cost can be lowered.

### SUMMARY

[0005] An objective of the present invention is to provide an on-chip inductor structure and a method for manufacturing the same, which uses a plurality of conductors disposed in a plurality of voids in a porous layer as the core of the inductor for increasing inductance and reducing occupied area.

[0006] Another objective of the present invention is to provide an on-chip inductor structure and a method for manufacturing the same, which has a simple structure with a manufacturing method compatible with the CMOS process, and hence reducing the cost.

[0007] Still another objective of the present invention is to provide an on-chip inductor structure and a method for manufacturing the same, which has a high-intensity anisotropy magnetic field, and hence the ferromagnetic resonance (FMR) frequency is increased.

[0008] The on-chip inductor structure according to the present invention comprises a substrate, a porous layer, a plurality of conductors, and an inductor. The manufacturing method according to the present invention comprises providing the substrate, forming the porous layer with a plurality of voids on the substrate, forming the plurality of conductors in the plurality of voids, and forming the inductor on the porous layer. Because the plurality of conductors is used as the core of the inductor, the inductance of the on-chip inductor is increased effectively while the occupied area is reduced effectively. Besides, because the manufacturing method according to the present invention is compatible with the current CMOS process, the manufacturing cost can be lowered.

### BRIEF DESCRIPTION OF THE DRAWINGS

[0009] FIG. 1 shows a structure of the on-chip inductor according to a preferred embodiment of the present invention;

[0010] FIG. 2 shows a top view of the on-chip inductor according to a preferred embodiment of the present invention; and

[0011] FIG. 3A to FIG. 3H show structural schematic diagrams of the manufacturing process for the on-chip inductor according to a preferred embodiment of the present invention.

### DETAILED DESCRIPTION

[0012] In order to make the structure and characteristics as well as the effectiveness of the present invention to be further understood and recognized, the detailed description of the present invention is provided as follows along with embodiments and accompanying figures.

[0013] FIG. 1 shows a structure of the on-chip inductor according to a preferred embodiment of the present invention. As shown in the figure, the on-chip inductor according to the present invention comprises a substrate **11**, a porous layer **15**, a plurality of conductors **153**, and an inductor **18**. The porous layer **15** is disposed on the substrate **11** and has a plurality of voids **151** thereon. The plurality of conductors **153** is disposed in the plurality of voids **151**. A preferred embodiment of the porous layer **15** of the on-chip inductor according to the present invention is a nanometer porous layer. The material of the conductors **153** can be any ferromagnetic material, including nickel. The porous layer **15** according to the present invention is a nonconductor. A preferred embodiment of the porous layer **15** is, but not limited to, an aluminum oxide layer.

[0014] Because the porous layer **15** according to the present invention is nonconductive and voids **151** do not communicate with each other, the conductors **153** are isolated electrically from each other. A preferred embodiment of the conductor **153** according to the present invention is pillar shaped. The depth-to-width ratio according to an embodiment of the conductor **153** is greater than 3:1. The geometry of the conductor **153** can be determined according to the thickness of the porous layer **15** and the diameter of the voids **151**. The inductor **18** is disposed on the porous layer **15**. An embodiment of the inductor according to the present invention is a spiral inductor, which comprises a plurality of coils **181** and an interconnection wire **185**. As shown in FIG. 2, the interconnection wire **185** is a crossover wire used for connecting to the innermost coil **181** of the inductor **18** and crossing over other coils **181**. According to an embodiment of the present invention, the shape of the inductor **18** can be any geometrical



shape, for example, a rectangle, an octagon, or a circle. The on-chip inductor structure according to the present invention further comprises an insulation layer **12** disposed on the substrate **11** and between the substrate **11** and the porous layer **15** for isolating electrically the substrate **11** and the porous layer **15**.

[0015] According to the present invention, the porous layer **15** is disposed, and the plurality of conductors **153** is disposed in the plurality of voids **151** of the porous layer **15** to form a composite material as the core. Thereby, the inductance of the inductor **18** is increased effectively. In comparison with the on-chip inductor according to the prior art, the on-chip inductor according to the present invention can be reduced effectively the occupied chip area by the inductor, and this achieving the objective of miniaturization. Additionally, the on-chip inductor according to the present invention has a simple structure, and hence lowering the production cost.

[0016] FIG. 3A to FIG. 3H show structural schematic diagrams of the manufacturing process for the on-chip inductor according to a preferred embodiment of the present invention. First, as shown in FIG. 3A, the substrate **11** is provided and the nonconductive layer **14** is formed on the substrate **11** for forming voids **151** in the nonconductive layer **14** and thus forming the porous layer **15** as shown in FIG. 3B. In addition, before the step of forming the porous layer **15**, the insulation layer **12** is firstly formed on the substrate **11** for isolating electrically the substrate **11** from the porous layer **15**. Next, as shown in FIG. 3B, the voids **151** are formed in the nonconductive layer **14** for forming the porous layer **15**. A preferred embodiment of the nonconductive layer **14** as described above is an aluminum oxide layer. Then, as shown in FIG. 3C, the conductors **153** are formed in the voids **151** for forming a composite material as the core. Afterwards, the subsequent step of forming the inductor **18** on the porous layer **15** can be performed.

[0017] In the step of forming the nonconductive layer **14** described above, an aluminum layer is formed first. Then, oxidizing the aluminum layer forms the aluminum oxide layer, namely, the nonconductive layer **14**. The above-mentioned method of forming the aluminum oxide layer as the nonconductive layer **14** is only an embodiment of the present invention. According to the present invention, evaporation deposition can be used for forming an aluminum layer on the substrate **11**. Then the anodizing process can be used to oxidize the aluminum layer for forming the nonconductive layer **14**. A method for fabricating the porous layer **15** according to the present invention is performing the anodizing process in various acid solutions on the aluminum layer. In the process, different specific parameters, such as applied voltage, current, temperature, and time, are controlled. These parameters have great correlation on the diameters and length of the plurality of voids **151**. An embodiment of the present invention is to put the aluminum layer in a 0.3M oxalic acid ( $\text{H}_2\text{C}_2\text{O}_4$ ) solution and apply 40 volts to the aluminum layer at room temperature until the aluminum layer is oxidized completely. Then the aluminum oxide layer is formed as the nonconductive layer **14**.

[0018] After the aluminum layer is oxidized completely, the aluminum oxide layer is annealed at 400° C. for two hours for reinforcing its structure. Then, dispose the annealed nonconductive layer **14** in a 5% phosphoric acid ( $\text{H}_3\text{PO}_4$ ) solution at 30° C. for 50 minutes for forming uniformly distributed nanometer voids **151**. The diameter of the plurality of voids **151** is 70 nm. Thereby, the porous layer **15** is formed.

Next, form the conductors **153** in the plurality of voids **151**. According to an embodiment of the present invention, immerse the porous layer **15** in tin chloride ( $\text{SnCl}_2$ ) solution for two minutes and palladium chloride ( $\text{PdCl}_2$ ) solution for 30 seconds, respectively, for activating the surface of the porous layer **15**. Subsequently, electroplate nickel to the porous layer **15** at 60° C. for one minute for forming the conductors **153** in the porous layer **15**. The electroplating described above can be electroless plating. Afterwards, polish the surface of the porous layer **15** for removing nickel thereon for isolating electrically the conductors **153** (nickel) in the plurality of voids **151** of the porous layer **15**, and thus reducing eddy current loss. Moreover, rapid thermal annealing can be further performed at 400° C. for two minutes for improving magnetic characteristics of the conductors **153**.

[0019] The method described above is only an embodiment of the present invention, not used for limiting the method for forming the porous layer **15**. Besides, the material of the conductors **153** is not limited to nickel. Any other ferromagnetic material can be used as well. By using the porous layer **15** and the conductors **153** as the core, the strength of anisotropy magnetic field is high, thus increasing the ferromagnetic resonance (FMR) frequency.

[0020] After the porous layer **15** is completed, the process of forming the inductor **18** can be performed subsequently. As shown in FIG. 3D, before forming the inductor **18**, the insulation layer **16** is firstly formed on the porous layer **15** and between the porous layer **15** and the inductor **18** for isolating electrically the porous layer **15** from the inductor **18**. According to the present invention, a method for forming the inductor **18** is electroplating as described in detail as follows. Referring to FIG. 3D, a first seed layer **17** is formed first on the insulation layer **16**. Next, as shown in FIG. 3E, form a first photoresist layer **21** on the first seed layer **17** according to the desired pattern of the coils **181** of the inductor **18** for masking part of the first seed layer **17**. Then, a first metal layer is formed on the part of the first seed layers **17** not masked by the first photoresist layer **21**. That is to say, the plurality of coils **181** of the inductor **18** is formed on the first seed layer **17**.

[0021] Next, as shown in FIG. 3F, remove the first photoresist layer **21** and form a second photoresist layer **22** on the first metal layer for masking the first metal layer, namely, masking the coils **181**. The pattern of the second photoresist layer **22** is bridge shaped for subsequently forming the interconnection wire **185**, namely, forming the crossover of the inductor **18** used for connecting to the innermost coil **181** of the inductor **18** and crossing over the rest of the coils **181**. Then, form a second seed layer **19** on the second photoresist layer **22** and form a third photoresist layer **23** on the second seed layer **19**. However, the third photoresist **23** does not mask completely the second seed layer **19**. Afterwards, referring to FIG. 3G, form a second metal layer on the second seed layer **19** not masked by the third photoresist layer **23** for forming the interconnection wire **185**. Finally, referring to FIG. 3H, remove the second and third photoresist layers **22**, **23**, and the on-chip inductor shown in FIG. 1 is thereby completed. The materials of the first and second metal layers described above include copper. In other words, the materials of the coils of the inductor **18** and of the interconnection wire **185** can be, but not limited to, copper. Additionally, the materials of the first and second seed layers **17**, **19** include copper as well. Moreover, the material of the first seed layer **17** further includes titanium.

[0022] Because the porous layer **15** is disposed on the substrate **11** and the conductors **153** are disposed in the voids **151** of the porous layer **15** for forming a composite material as the core, the inductance can be increased effectively while reducing the area occupied by the inductor **18** effectively for achieving the required inductance. In addition, because the process according to the present invention is simple and compatible with the current CMOS process, while performing the CMOS process according to the prior art, the on-chip inductor according to the present invention can be manufactured simultaneously. Thereby, no special equipment is needed and hence the cost can be lowered. Besides, the present invention is suitable for inductors of any geometrical shapes without limitations. According to the present invention, by increasing the distribution density of the voids **151** of the porous layer **15**, the inductance of the inductor **18** can be increased. Furthermore, according to the present invention, because the conductors **153** are used as the core of the inductor **18**, the FMR frequency can be increased and hence the influence of ferromagnetic resonance can be eliminated. Consequently, the Q performance of the inductor **18** is maintained.

[0023] To sum up, the on-chip inductor structure according to the present invention comprises a substrate, a porous layer, a plurality of conductors, and an inductor. The manufacturing method according to the present invention comprises providing a substrate, forming a porous layer with a plurality of voids on the substrate, forming a plurality of conductors isolated from each other in the plurality of voids, and forming an inductor on the porous layer. Because the plurality of conductors is used as the core of the inductor, the inductance of the on-chip inductor is increased effectively and still increases at high frequencies. Thereby, the area occupied by the inductor is reduced effectively, which is beneficial for miniaturization. Besides, because the manufacturing method according to the present invention is compatible with the current CMOS process, the manufacturing cost can be lowered.

[0024] Accordingly, the present invention conforms to the legal requirements owing to its novelty, nonobviousness, and utility. However, the foregoing description is only embodiments of the present invention, not used to limit the scope and range of the present invention. Those equivalent changes or modifications made according to the shape, structure, feature, or spirit described in the claims of the present invention are included in the appended claims of the present invention.

1. An on-chip inductor structure, comprising:
  - a substrate;
  - a porous layer, disposed on said substrate, and having a plurality of voids;
  - a plurality of conductors, disposed in said plurality of voids; and
  - an inductor, disposed on said porous layer.
2. The on-chip inductor structure of claim **1**, and further comprising an insulation layer, disposed on said substrate, and between said substrate and said porous layer.
3. The on-chip inductor structure of claim **1**, and further comprising an insulation layer, disposed on said porous layer, and between said porous layer and said inductor.
4. The on-chip inductor structure of claim **1**, wherein said inductor includes a plurality of coils.
5. The on-chip inductor structure of claim **1**, wherein said porous layer is a nanometer porous layer.

6. The on-chip inductor structure of claim **1**, wherein the material of said plurality of conductors is a ferromagnetic material.

7. The on-chip inductor structure of claim **6**, wherein the material of the ferromagnetic material includes nickel.

8. The on-chip inductor structure of claim **1**, wherein said conductors are isolated from each other.

9. The on-chip inductor structure of claim **1**, wherein said conductors are pillar shaped.

10. The on-chip inductor structure of claim **9**, wherein the depth-to-width ratio of said conductors is greater than 3:1.

11. The on-chip inductor structure of claim **1**, wherein said porous layer is a nonconductor.

12. The on-chip inductor structure of claim **1**, wherein said porous layer is an aluminum oxide layer.

13. A method for manufacturing an on-chip inductor structure, comprising steps of: providing a substrate;

forming a porous layer having a plurality of voids on said substrate;

forming a plurality of conductors in said plurality of voids; and

forming an inductor on said porous layer.

14. The method for manufacturing an on-chip inductor structure of claim **13**, and before said step of forming said porous layer having said plurality of voids on said substrate, further comprising a step of forming an insulation layer on said substrate.

15. The method for manufacturing an on-chip inductor structure of claim **13**, and before said step of forming said inductor on said porous layer, further comprising a step of forming an insulation layer on said porous layer.

16. The method for manufacturing an on-chip inductor structure of claim **13**, wherein said porous layer is a nonconductor.

17. The method for manufacturing an on-chip inductor structure of claim **13**, wherein said step of forming said porous layer having said plurality of voids on said substrate further comprises steps of:

forming a nonconductive layer on said substrate; and

forming said plurality of voids in said nonconductive layer for forming said porous layer.

18. The method for manufacturing an on-chip inductor structure of claim **17**, wherein said nonconductive layer includes aluminum oxide.

19. The method for manufacturing an on-chip inductor structure of claim **17**, wherein said step of forming said nonconductive layer on said substrate further comprises steps of: forming an aluminum layer on said substrate; and oxidizing said aluminum layer for forming said nonconductive layer.

20. The method for manufacturing an on-chip inductor structure of claim **19**, wherein the method of forming said aluminum layer on said substrate includes evaporation deposition.

21. The method for manufacturing an on-chip inductor structure of claim **19**, wherein the method of oxidizing said aluminum layer for forming said nonconductive layer includes anodizing process.

22. The method for manufacturing an on-chip inductor structure of claim **13**, wherein said porous layer is a nanometer porous layer.

23. The method for manufacturing an on-chip inductor structure of claim **13**, wherein the material of said plurality of conductors is a ferromagnetic material.

**24.** The method for manufacturing an on-chip inductor structure of claim **13**, wherein the material of the ferromagnetic material includes nickel.

**25.** The method for manufacturing an on-chip inductor structure of claim **13**, wherein said conductors are isolated from each other.

**26.** The method for manufacturing an on-chip inductor structure of claim **13**, wherein said conductors are pillar shaped.

**27.** The method for manufacturing an on-chip inductor structure of claim **26**, wherein the depth-to-width ratio of said conductors is greater than 3:1.

**28.** The method for manufacturing an on-chip inductor structure of claim **13**, wherein the method of forming said plurality of conductors includes electroless plating.

**29.** The method for manufacturing an on-chip inductor structure of claim **13**, wherein the method of forming said inductor includes electroplating.

**30.** The method for manufacturing an on-chip inductor structure of claim **13**, wherein the step of forming said inductor on said porous layer includes:

- forming a first seed layer;
- forming a first photoresist layer on said first seed layer;
- forming a first metal layer on said first seed layer;
- removing said first photoresist layer;
- forming a second photoresist on said first metal layer;
- forming a second seed layer on said second photoresist layer;
- forming a third photoresist layer on said second seed layer;
- forming a second metal layer on said second seed layer;
- and
- removing said second photoresist layer, said third photoresist layer, said first seed layer, and said second seed layer.

**31.** The method for manufacturing an on-chip inductor structure of claim **30**, wherein said first metal layer and said second metal layer include copper.

\* \* \* \* \*