



US 20100098731A1

(19) **United States**

(12) **Patent Application Publication**
Chen et al.

(10) **Pub. No.: US 2010/0098731 A1**

(43) **Pub. Date: Apr. 22, 2010**

(54) **HOLLOW SPHERE FROM AMPHIPHILIC CHITOSAN DERIVATIVES AND METHOD OF PREPARING AMIPHILIC CHITOSAN DERIVATIVE COMPLEX FOR MEDICAL USE**

(75) Inventors: **San-Yuan Chen**, Hsinchu City (TW); **Kun-Ho Liu**, Hualien City (TW); **Dean-Mo Liu**, Jhubei City (TW)

Correspondence Address:
BACON & THOMAS, PLLC
625 SLATERS LANE, FOURTH FLOOR
ALEXANDRIA, VA 22314-1176 (US)

(73) Assignee: **National Chiao Tung University**, Hsinchu City (TW)

(21) Appl. No.: **12/379,880**

(22) Filed: **Mar. 4, 2009**

(30) **Foreign Application Priority Data**

Oct. 16, 2008 (TW) 097139732

Publication Classification

(51) **Int. Cl.**
A61K 9/00 (2006.01)
(52) **U.S. Cl.** **424/400; 977/906**

(57) **ABSTRACT**

A hollow sphere from amphiphilic chitosan derivatives and a method of preparing an amphiphilic chitosan derivative complex for medical use are disclosed, and the hollow sphere from amphiphilic chitosan derivatives comprises: chitosan derivatives represented by the following formula (I), which self-assemble and form a hollow sphere in a solvent;

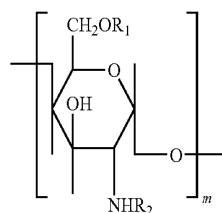

wherein, each R_1 is independently hydrogen, C_1 - C_4 alkyl, C_1 - C_6 carboxyl, sulfate group, or phosphate group, each R_2 is independently hydrogen, C_1 - C_{12} alkyl, C_1 - C_6 carboxyl, or C_2 - C_{12} acyl group, and m is an integer of 100-2000.

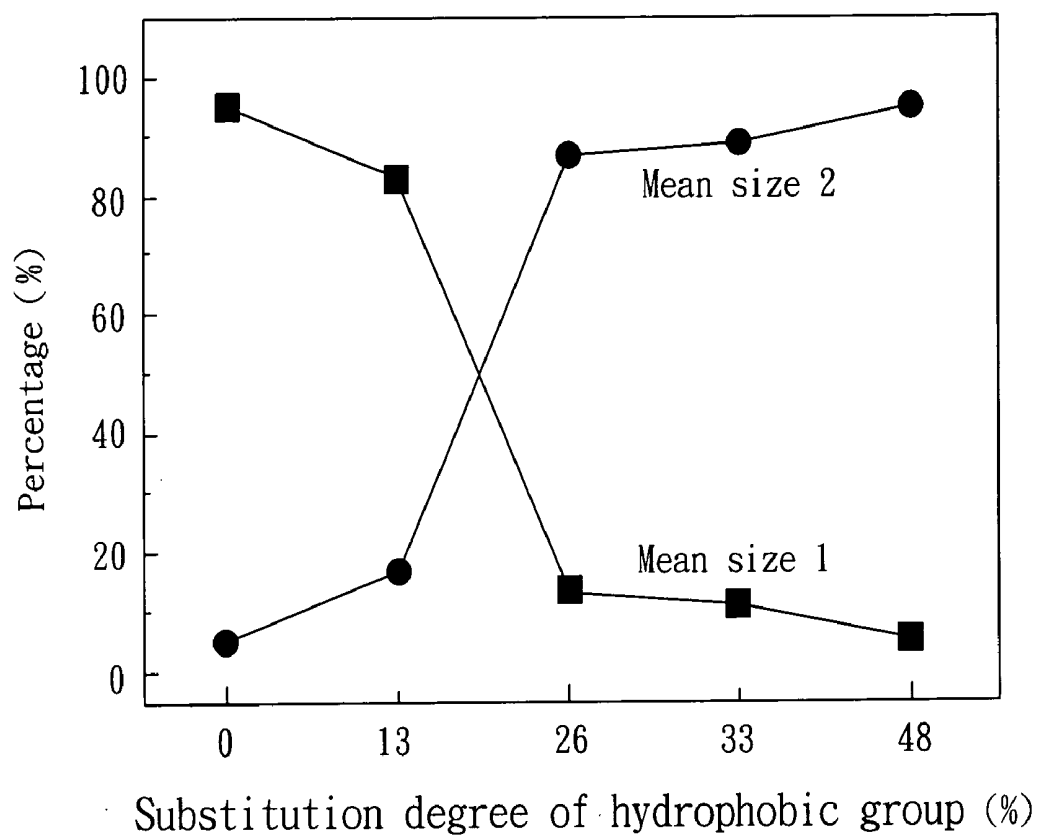

FIG. 1

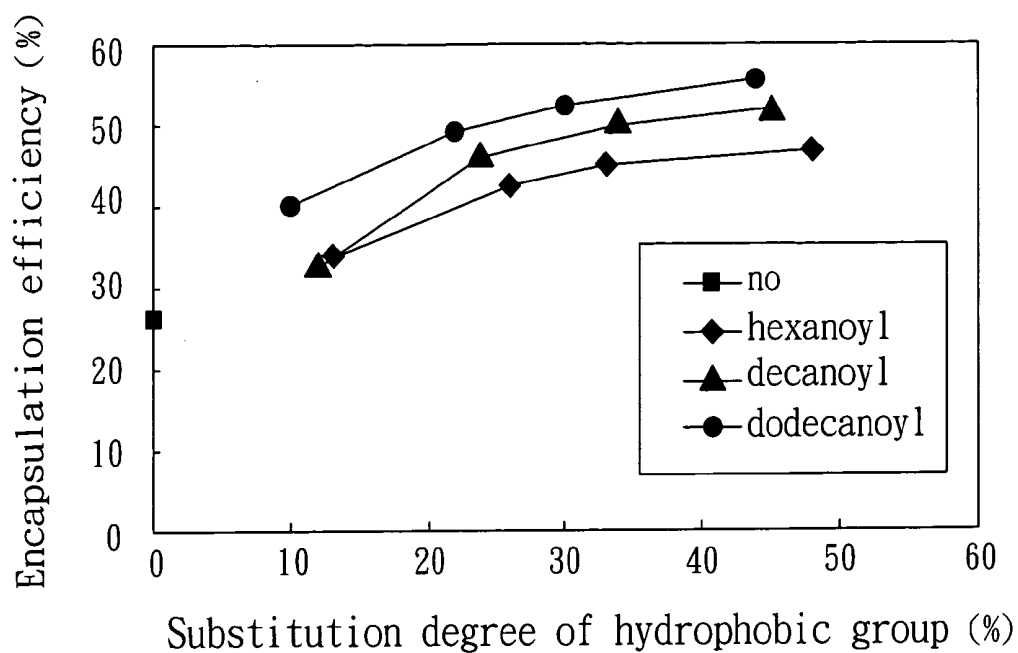

FIG. 2

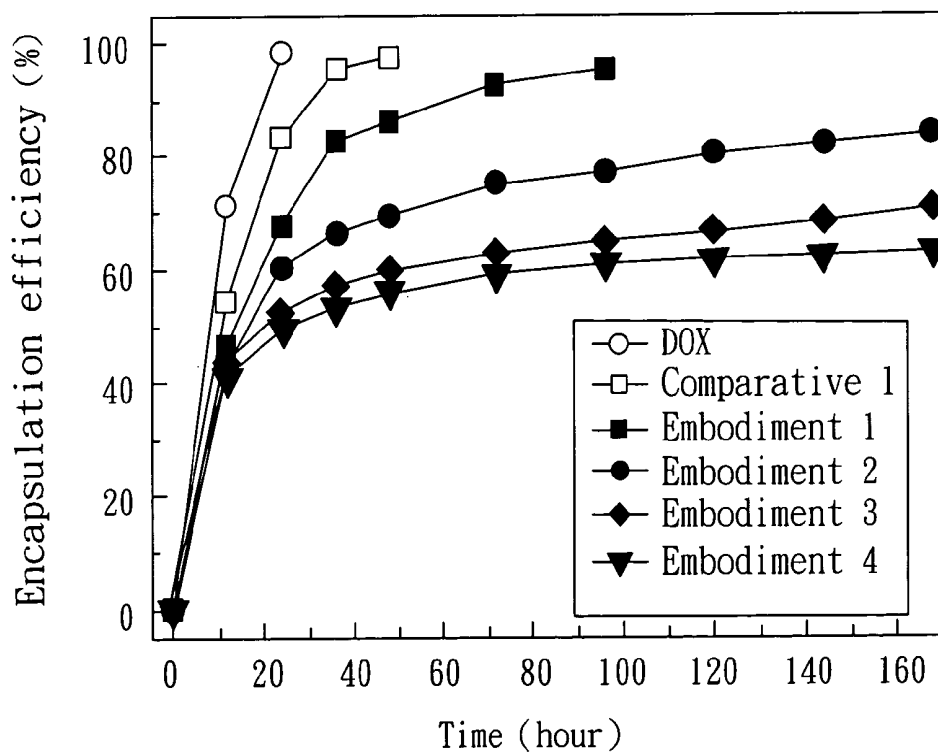

FIG. 3

**HOLLOW SPHERE FROM AMPHIPHILIC
CHITOSAN DERIVATIVES AND METHOD OF
PREPARING AMPHIPHILIC CHITOSAN
DERIVATIVE COMPLEX FOR MEDICAL USE**

BACKGROUND OF THE INVENTION

[0001] 1. Field of the Invention

[0002] The present invention relates to a hollow sphere from amphiphilic chitosan derivatives and a method of preparing an amphiphilic chitosan derivative complex for medical use and, more particularly, to a hollow sphere from amphiphilic chitosan derivatives and a method of preparing an amphiphilic chitosan derivative complex for medical use, which can be applied for anticancer drug delivery.

[0003] 2. Description of Related Art

[0004] Currently, anticancer drug carriers have developed for anticancer chemotherapy, and liposome is considered to be an ideal drug carrier due to its unique properties to target cancer. Especially, the liposome encapsulates drugs and releases drugs at a tumor area but does not pass through normal tissue, so that the probability of destroying normal cells can be reduced. However, the liposome shows low encapsulation efficiency, high-priced processing, insufficient stability, and poor biocompatibility, so that there are still some problems in applying the liposome in the clinical treatment. Hence, there has been some research in natural polymers with good biocompatibility, in order to develop an efficient drug carrier system for anticancer chemotherapy.

[0005] Among the well-known natural polymers, chitosan is considered to be able to be applied on drug carriers, due to its low cost, high biocompatibility, and degradability. Generally, chitosan is derived from chitin by removing acetyl groups. This process, called deacetylation, release amino groups and gives the chitosan a cationic characteristic. The formula of the chitosan is represented as follows:

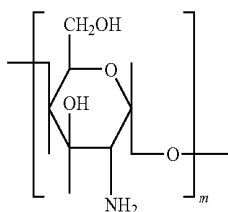

[0006] The chitosan has advantages of low price and good biocompatibility, and the double layer structure of the liposome is considered to be an ideal form for drug carriers. Hence, if the chitosan can be processed and form a double layer structure similar to the liposome, it is possible to apply the double layer structure made from the chitosan to the carriers for drug delivery efficiently. Presently, the double layer structure made from the chitosan is synthesized by template-coating or layer-by-layer building. However, the aforementioned methods have the disadvantages of complicated processing and high cost, so that it is difficult to be commercialized.

[0007] Therefore, it is desirable to develop a drug carrier for anticancer chemotherapy, which has a double layer structure

similar to the liposome and the characteristics of the chitosan, such as low cost, high biocompatibility, and degradability.

SUMMARY OF THE INVENTION

[0008] The object of the present invention is to provide a hollow sphere from amphiphilic chitosan derivatives, which is formed through the self-assembling of the amphiphilic chitosan derivatives. Moreover, the hollow sphere from the amphiphilic chitosan derivatives of the present invention can be used for drug carriers of anticancer chemotherapy.

[0009] Another object of the present invention is to provide a method of preparing amphiphilic chitosan derivative complex for medical use, and an active component can be effectively encapsulated inside a hollow sphere self-assembling from the amphiphilic chitosan derivatives. At the same time, the encapsulation efficiency for the active component can be improved by the method of preparing the present invention.

[0010] To achieve the aforementioned objects, the hollow sphere from amphiphilic chitosan derivatives of the present invention includes: chitosan derivatives represented by the following formula (I), which self-assemble and form a hollow sphere in a solvent;

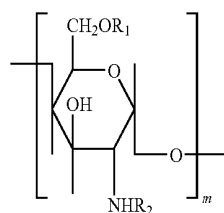

(I)

[0011] wherein, each R_1 independently is hydrogen, $C_1\sim C_4$ alkyl, $C_1\sim C_6$ carboxyalkyl, sulfate ($-\text{SO}_3$), or phosphate ($-\text{H}_2\text{PO}_4$); each R_2 independently is hydrogen, $C_1\sim C_{12}$ alkyl, $C_1\sim C_6$ carboxyalkyl, or $C_2\sim C_{12}$ acyl; and m is an integral of 100~2000.

[0012] In addition, the present invention also provides a method of preparing an amphiphilic chitosan derivative complex for medical use, comprising following steps: (A) providing a chitosan, and substituting at least one hydrophilic group, and at least one hydrophobic group on the chitosan to obtain chitosan derivatives; (B) dissolving the chitosan derivatives in a solvent to obtain a solution of the chitosan derivatives; and (C) mixing the solution of the chitosan derivatives, and active components, to form hollow spheres through the self-assembling of the chitosan derivatives, wherein the active components are encapsulated inside the hollow spheres.

[0013] The amphiphilic chitosan derivatives of the present invention can be substituted with hydrophilic groups and hydrophobic groups on the chitosan at the same time, because the chemical modification of the chitosan can be easily accomplished. Beside, the amphiphilic chitosan derivatives can self-assemble to form a hollow sphere with a double layer structure similar to the liposome, i.e. hydrophilic-hydrophobic-hydrophilic configuration, due to the hydrophobicity of the amphiphilic chitosan derivatives. Additionally, the hollow structure of the hollow sphere can improve the drug loading of the active components. Moreover, the outer layer of the hollow sphere from the amphiphilic chitosan derivatives of the present invention has hydrophilicity, so the biocompatibility and the affinity for water can be improved, and the harm to

normal tissue can be reduced at the same time. Furthermore, the hollow sphere from the amphiphilic chitosan derivatives and the amphiphilic chitosan derivative complex for medical use of the present invention have the advantages of simple processability, low cost, and high biocompatibility, so it is possible to replace the liposome as drug carriers.

[0014] According to the hollow sphere from the amphiphilic chitosan derivatives and the method of preparing the amphiphilic chitosan derivative complex for medical use of the present invention, each R_1 of the chitosan derivatives of formula (I) independently may be hydrogen, carboxymethyl, carboxyl, sulfate, phosphate, trimethyl, or succinyl. Preferably, each R_1 independently is hydrogen, or carboxymethyl.

[0015] According to the hollow sphere from amphiphilic chitosan derivatives and the method of preparing the amphiphilic chitosan derivative complex for medical use of the present invention, each R_2 of the chitosan derivatives of formula (I) independently may be hydrogen, $C_1\sim C_{12}$ alkyl, $C_1\sim C_6$ carboxyalkyl, $C_2\sim C_{12}$ acyl, tosyl, phthaloyl, or silyl. Preferably, each R_2 independently is hydrogen, carboxymethyl, or $C_2\sim C_{12}$ acyl. More preferably, each R_2 independently is hydrogen, or $C_2\sim C_{12}$ acyl.

[0016] According to the hollow sphere from amphiphilic chitosan derivatives and the method of preparing the amphiphilic chitosan derivative complex for medical use of the present invention, the chitosan derivatives are compounds represented by the following formula (II),

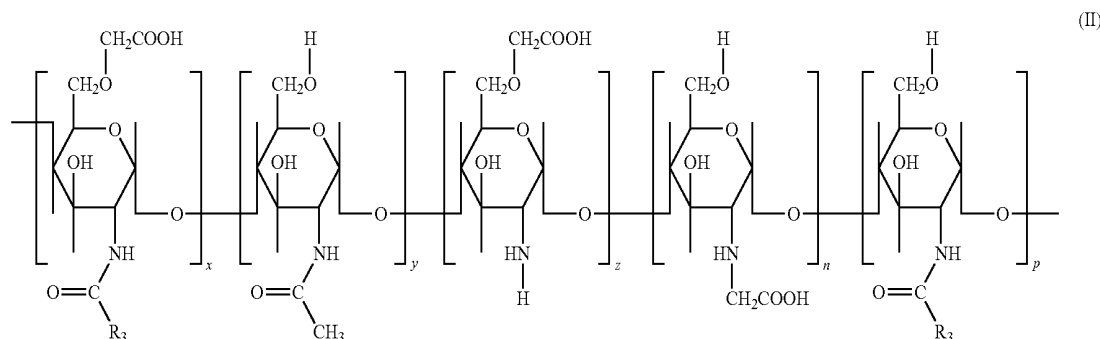

[0017] wherein, each R_3 independently is $C_5\sim C_{11}$ alkyl; and x , y , z , n , and p independently are integrals of 20~2000.

[0018] According to the hollow sphere from amphiphilic chitosan derivatives and the method of preparing the amphiphilic chitosan derivative complex for medical use of the present invention, the hollow sphere has a mean size of 10~500 nm.

[0019] According to the hollow sphere from amphiphilic chitosan derivatives and the method of preparing the amphiphilic chitosan derivative complex for medical use of the present invention, the solvent may be water solution, organic solvent, or any mixture solution.

[0020] According to the hollow sphere from amphiphilic chitosan derivatives and the method of preparing the amphiphilic chitosan derivative complex for medical use of the present invention, the temperature for self-assembling of chitosan derivatives may be 0~80° C.

[0021] According to the method of preparing the amphiphilic chitosan derivative complex for medical use of the present invention, the chitosan has the molecular weight

of 1000-400,000 g/mol. In addition, the deacetylation degree of the chitosan is 65%~100%. Herein, "deacetylation degree" means the percentage of removing the acetyl groups on the chitin.

[0022] According to the method of preparing the amphiphilic chitosan derivative complex for medical use of the present invention, the hydrophilic group may be selected from the group consisting of carboxymethyl, carboxyl, sulfate, phosphate, trimethyl, and succinyl, and the hydrophobic group may be selected from the group consisting of $C_1\sim C_{12}$ alkyl, $C_2\sim C_{12}$ acyl, tosyl, phthaloyl, or silyl.

[0023] According to the method of preparing the amphiphilic chitosan derivative complex for medical use of the present invention, the substitution degree of the hydrophobic group is 5~100%. Herein, "substitution degree of hydrophobic group" means the percentage of substituting the amino groups of the chitosan with the hydrophobic groups.

[0024] In addition, according to the method of preparing the amphiphilic chitosan derivative complex for medical use of the present invention, the step (C) further may be: mixing and sonicating the solution of the chitosan derivatives, and active components, to form hollow spheres through the self-assembling of the chitosan derivatives, wherein the active components are encapsulated inside the hollow spheres.

[0025] Furthermore, according to the method of preparing the amphiphilic chitosan derivative complex for medical use of the present invention, the active component is a drug.

[0026] Other objects, advantages, and novel features of the invention will become more apparent from the following detailed description when taken in conjunction with the accompanying drawings.

BRIEF DESCRIPTION OF THE DRAWINGS

[0027] FIG. 1 is a diagram illustrating the relation between the substitution degree of hydrophobic group and the mean size of the hollow sphere from the amphiphilic chitosan derivatives of the present invention;

[0028] FIG. 2 is a diagram illustrating the relation between the substitution degree of hydrophobic group and the encapsulation efficiency of the hollow sphere from the amphiphilic chitosan derivatives of the present invention; and

[0029] FIG. 3 is a diagram illustrating the relation between the substitution degree of hydrophobic group and the drug release percentage of the hollow sphere from the amphiphilic chitosan derivatives of the present invention.

DETAILED DESCRIPTION OF THE PREFERRED EMBODIMENT

COMPARATIVE EXAMPLE 1

Synthesis of Chitosan Derivatives with Hydrophilic Carboxymethyl Modification

[0030] 5 g of chitosan ($M_w=215,000$ g/mol, deacetylation degree=80-90%, Adrich-Sigma) was suspended in 2-propanol (50 mL) at room temperature while being stirred for 30 min. The resulting suspension was gently mixed with 12.5 mL of NaOH solution to obtain a mixture, and the substitution degree of hydrophilic group can be adjusted by the concentration of NaOH in the mixture. Herein, the mixture contained 13.3 M NaOH. Then, the mixture was reacted with chloroacetic acid, followed by drying, to obtain soluble carboxymethyl-modified chitosan sample.

Embodiment 1

Synthesis of Chitosan Derivatives with Hydrophobic Hexanoyl Modification and Hydrophilic Carboxymethyl Modification

[0031] 2g of dried chitosan derivatives with hydrophilic carboxymethyl modification prepared in Comparative example 1 was dissolved in distilled water (50 mL) while being stirred for 24 hours. Then, the resulting solution was mixed with methanol (50 mL), followed by the addition of hexanoyl anhydride at concentration of 0.2 M to obtain a reaction solution. After reacting for 20 hours, the reaction solution was collected by dialysis with ethanol solution (25% v/v) for 24 hours. After drying the resulting solution, chitosan derivatives with hydrophobic hexanoyl modification and hydrophilic carboxymethyl modification, called amphiphilic chitosan derivatives, were obtained, which can be represented by the following formula (II). In addition, the sites of the substitution groups and the degree of hexanoyl substitution were confirmed by ^1H NMR and elemental analysis for N content. In the present embodiment, the degree of hexanoyl substitution of the chitosan derivatives is 13%.

Embodiment 2

[0032] The reaction condition and steps in the present embodiment are the same as those in Embodiment 1, except that the concentration of the hexanoyl anhydride is 0.4 M. The degree of hexanoyl substitution of the chitosan derivatives prepared in the present embodiment is 26%.

Embodiment 3

[0033] The reaction condition and steps in the present embodiment are the same as those in Embodiment 1, except that the concentration of the hexanoyl anhydride is 0.5 M. The degree of hexanoyl substitution of the chitosan derivatives prepared in the present embodiment is 33%.

Embodiment 4

[0034] The reaction condition and steps in the present embodiment are the same as those in Embodiment 1, except that the concentration of the hexanoyl anhydride is 1.0 M. The degree of hexanoyl substitution of the chitosan derivatives prepared in the present embodiment is 48%.

Embodiment 5

[0035] The reaction condition and steps in the present embodiment are the same as those in Embodiment 1, except that hexanoyl anhydride is substituted with decanoic anhydride. The degree of decanoyl substitution of the chitosan derivatives prepared in the present embodiment is 12%.

Embodiment 6

[0036] The reaction condition and steps in the present embodiment are the same as those in Embodiment 2, except that hexanoyl anhydride is substituted with decanoic anhydride. The degree of decanoyl substitution of the chitosan derivatives prepared in the present embodiment is 24%.

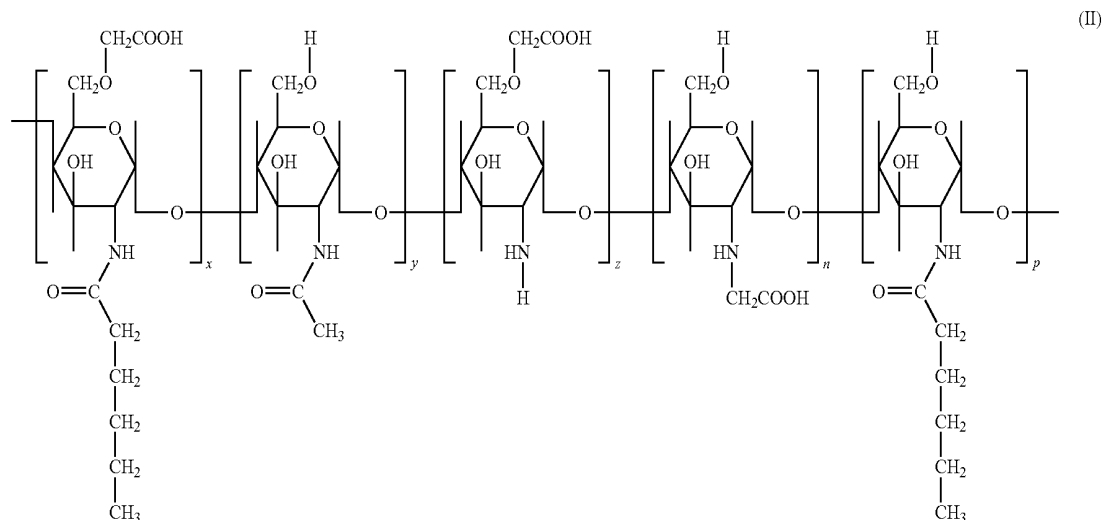

Embodiment 7

[0037] The reaction condition and steps in the present embodiment are the same as those in Embodiment 3, except that hexanol anhydride is substituted with decanoic anhydride. The degree of decanoyl substitution of the chitosan derivatives prepared in the present embodiment is 34%.

Embodiment 8

[0038] The reaction condition and steps in the present embodiment are the same as those in Embodiment 4, except that hexanol anhydride is substituted with decanoic anhydride. The degree of decanoyl substitution of the chitosan derivatives prepared in the present embodiment is 45%.

Embodiment 9

[0039] 2g of dried chitosan derivatives with hydrophilic carboxymethyl modification prepared in Comparative example 1 was dissolved in distilled water (50 mL) while being stirred for 24 hours. Then, the resulting solution was mixed with methanol (50 mL), followed by the addition of dodecanoic anhydride at concentration of 0.2 M to obtain a reaction solution. The reaction solution was reacted under 50° C. for 20 hours, followed by being reacted at room temperature for 18 hours, and then the reaction solution was collected by dialysis with ethanol solution (25% v/v) for 24 hours. After drying the resulting solution, a chitosan derivatives with hydrophobic dodecanoyl modification and hydrophilic carboxymethyl modification, called amphiphilic chitosan derivatives were obtained. In addition, the sites of the substitution groups and the degree of dodecanoyl substitution were confirmed by ¹H NMR and elemental analysis for N content. In the present embodiment, the degree of dodecanoyl substitution of the chitosan derivatives is 10%.

Embodiment 10

[0040] The reaction condition and steps in the present embodiment are the same as those in Embodiment 9, except that the concentration of the dodecanoic anhydride is 0.4 M. The degree of dodecanoyl substitution of the chitosan derivatives prepared in the present embodiment is 22%.

Embodiment 11

[0041] The reaction condition and steps in the present embodiment are the same as those in Embodiment 9, except that the concentration of the dodecanoic anhydride is 0.5 M.

The degree of dodecanoyl substitution of the chitosan derivatives prepared in the present embodiment is 30%.

Embodiment 12

[0042] The reaction condition and steps in the present embodiment are the same as those in Embodiment 9, except that the concentration of the dodecanoic anhydride is 1.0 M. The degree of dodecanoyl substitution of the chitosan derivatives prepared in the present embodiment is 44%.

Preparation of Hollow Spheres from Amphiphilic Chitosan Derivatives

[0043] 100 mg/ml of chitosan derivatives prepared by Comparative example 1 and Embodiments 1-12 was suspended in a distilled water under gentle shaking at room temperature for 24 hours, followed by ultrasonication using a probe type sonifier (Automatic Ultrasonic Processor UH-500A) for 2 min. After repeating the sonication three times, the final products were obtained.

[0044] In order to identify whether the products were in a form of sphere, Transmission Electron Microscopy (TEM) (JEOL2100, Japan) was used to check the shape of the products and determine the size of the products. According to TEM image, it can be found that the amphiphilic chitosan derivatives can self-assemble to form hollow spheres with nano or micro sizes, through the interaction between the hydrophobic groups, wherein the hollow spheres have a double layer structure, i.e. hydrophilic-hydrophobic-hydrophilic configuration.

Characterization of the Hollow Spheres from the Amphiphilic Chitosan Derivatives

[0045] The mean size and size distribution of the hollow spheres from the amphiphilic chitosan derivatives prepared by Comparative example 1 and Embodiments 1-4 were measured by dynamic light scattering (DLS) Nanoparticle Size Analyzer (LB-550, HORIBA, Japan). In addition, the critical aggregation concentration (CAC) of the amphiphilic chitosan derivatives was obtained from the fluorescent spectrum, wherein pyrene was used as a fluorescence probe due to its high affinity to hydrophobic micro-domains. The smaller of the critical aggregation concentration means the easier of forming hollow spheres. The characters of the mean size and the critical aggregation concentration of the hollow spheres from the amphiphilic chitosan derivatives are shown in Table 1.

TABLE 1

| | Hydrophobic group | Substitution degree of hydrophobic group | CAC × 10 ⁻² (mg/mL) | Mean size 1 (nm) | Mean size 2 (nm) |
|-----------------------|-------------------|--|--------------------------------|------------------|------------------|
| Comparative example 1 | — | 0% | 25.0 | 19.8 ± 1.2 | 189.2 ± 2.4 |
| Embodiment 1 | Hexanoyl | 13% | 9.21 | 21.5 ± 1.6 | 210.5 ± 1.9 |
| Embodiment 2 | Hexanoyl | 26% | 3.17 | 22.3 ± 0.7 | 209.3 ± 1.4 |
| Embodiment 3 | Hexanoyl | 33% | 0.91 | 22.9 ± 1.1 | 210.9 ± 0.7 |
| Embodiment 4 | Hexanoyl | 48% | 0.40 | 23.5 ± 0.7 | 222.7 ± 2.0 |
| Embodiment 5 | Decanoyl | 12% | 6.20 | — | — |
| Embodiment 6 | Decanoyl | 24% | 1.80 | — | — |
| Embodiment 7 | Decanoyl | 34% | 0.57 | — | — |
| Embodiment 8 | Decanoyl | 45% | 0.36 | — | — |

TABLE 1-continued

| | Hydrophobic group | Substitution degree of hydrophobic group | CAC $\times 10^{-2}$ (mg/mL) | Mean size 1 (nm) | Mean size 2 (nm) |
|---------------|-------------------|--|------------------------------|------------------|------------------|
| Embodiment 9 | Dodecanoyl | 10% | 5.00 | — | — |
| Embodiment 10 | Dodecanoyl | 22% | 1.20 | — | — |
| Embodiment 11 | Dodecanoyl | 30% | 0.36 | — | — |
| Embodiment 12 | Dodecanoyl | 44% | 0.32 | — | — |

[0046] From the results shown in Table 1, the amphiphilic chitosan derivatives can form two kinds of hollow spheres with different mean sizes. As the substitution degree of hydrophobic group increases, the amphiphilic chitosan derivatives tend to form hollow spheres with mean size 2. FIG. 1 shows the relation between the substitution degree of hydrophobic group and mean size distribution. As shown in FIG. 1, most of the amphiphilic chitosan derivatives prepared in Embodiments 3 and 4 form hollow spheres with a particle size of 200 nm.

Measurement of the Thickness of the Shells of the Hollow Spheres from the Amphiphilic Chitosan Derivatives

[0047] In order to confirm the amphiphilic chitosan derivatives forming hollow spheres, the hollow spheres from the amphiphilic chitosan derivatives were dehydrated to remove water inside and outside the hollow spheres. Then, Scanning Electron-Microscopy (SEM) (S6500, JEOL, Japan) was used for detecting the dehydrated hollow spheres from amphiphilic chitosan derivatives. SEM image shows that the hollow spheres with particle size of 200 nm each lost their structural integrity, and collapsed to resemble a flattened basketball after dehydration. Furthermore, the thickness of the double shell is about 9 nm, which can be found from SEM image, so the thickness of the single shell is calculated to be about 4.5 nm.

Measurement of the Encapsulation Efficiency of the Hollow Sphere from Amphiphilic Chitosan Derivatives

[0048] Doxorubicin (DOX) was provided and mixed with 20 mL of chitosan derivatives solution prepared by using Comparative example 1 and Embodiments 1-12, respectively. The final concentration of the DOX in the chitosan derivatives solution is 20 $\mu\text{g/mL}$. After stirring for 24 hours, the resulting solution was ultrasonicated with sonicator (Automatic Ultrasonic Processor UH-500A), and the chitosan derivatives self-assembled to form hollow spheres, wherein the DOX was encapsulated inside the hollow spheres to form an amphiphilic chitosan derivative complex for medical use. Insoluble and free DOX was removed by centrifugation at 2000 rpm under 4° C. for 5 mins. Then, the amphiphilic chitosan derivative complex for medical use was separated from the solution by centrifugation at 15000 rpm under 4° C. for 15 mins. Free DOX concentration in the supernatant was analyzed by UV-VIS spectrometer (SP-8001, Metertech Inc.). Encapsulation efficiency (EE) of the hollow sphere from amphiphilic chitosan derivatives can be calculated with

the DOX concentration. Herein, encapsulation efficiency was obtained as described below:

$$EE = (A - B) / A \times 100$$

[0049] wherein, A is the total amount of the DOX, and B is the amount of DOX remaining in the supernatant. The calculation results are shown in FIG. 2, wherein X-axis is the substitution degree of hydrophobic group, and Y-axis is encapsulation efficiency. As shown in FIG. 2, as the substitution degree of hydrophobic group and the length of the side chain of the hydrophobic group are increased, the encapsulation efficiency also is improved. The improved encapsulation efficiency is caused by the increase of the hydrophobic interaction of inner shell of the hollow sphere, which can restrict the outward diffusion of DOX from the hollow sphere. Hence, the release behavior of drugs can be controlled by adjusting the substitution degree and the length of side chain of the hydrophobic group.

Drug Release Behavior of the Hollow Sphere from Amphiphilic Chitosan Derivatives

[0050] A solution of DOX and DOX-amphiphilic chitosan derivative complex prepared with the amphiphilic chitosan derivatives in Embodiments 1-4 was dialyzed against 0.1 M buffer (100 mL) under 37° C. The DOX concentration in the buffer was measured at various times over a 7-day period to detect the drug release behavior of the hollow spheres from the amphiphilic chitosan derivatives. The results are shown in FIG. 3, wherein X-axis is the substitution degree of hydrophobic group, and Y-axis is the releasing percentage of the DOX. As shown in FIG. 3, DOX is not easily released from the hollow spheres while the substitution degree of the hydrophobic group is increased, so that it is possible to release drugs for a long time. Hence, the drug release behavior of the hollow spheres can be controlled by adjusting the substitution degree of the hydrophobic group. Therefore, the hollow sphere from the amphiphilic chitosan derivatives of the present invention can be a suitable candidate for delivery of anticancer drugs.

[0051] In conclusion, the amphiphilic chitosan derivatives with hydrophilic and hydrophobic modification of the present invention can form hollow a sphere by self-assembling, wherein the size of the hollow sphere is about 20-200 nm, and the hollow sphere has a double layer structure, i.e. hydrophilic-hydrophobic-hydrophilic configuration. Hence, comparing with the chitosan hollow sphere prepared by template-coating or layer-by-layer building, the process of hollow sphere from chitosan derivatives is simpler and cheaper. Also, the hollow sphere from the amphiphilic chitosan derivatives of the present invention is formed through the self-assembling, so the hollow sphere can encapsulate drug without destroying the drug activity. In addition, the hollow sphere from the amphiphilic chitosan derivatives of the present invention not only can maintain the stability of the active

component, but also can improve the encapsulation efficiency of the hollow sphere. Furthermore, in order to control the encapsulation efficiency and the drug release behavior of the hollow sphere from the amphiphilic chitosan derivatives of the present invention, the critical aggregation concentration and surface character of the hollow sphere can be adjusted through modifying the kinds, substitution degree, and the length of the side chain of the hydrophobic group. Therefore, the hollow sphere from the amphiphilic chitosan derivatives of the present invention can be used in substitution for the liposome, and serve as the drug carriers for anticancer chemotherapy.

[0052] Although the present invention has been explained in relation to its preferred embodiment, it is to be understood

hydrogen, carboxymethyl, carboxyl, sulfate, phosphate, trimethyl, or succinyl.

3. The hollow sphere from amphiphilic chitosan derivatives as claimed in claim 1, wherein each R_1 independently is hydrogen, or carboxymethyl.

4. The hollow sphere from amphiphilic chitosan derivatives as claimed in claim 1, wherein each R_2 independently is hydrogen, C_1 ~ C_{12} alkyl, C_1 ~ C_6 carboxyalkyl, C_2 ~ C_{12} acyl, tosyl, phthaloyl, or silyl.

5. The hollow sphere from amphiphilic chitosan derivatives as claimed in claim 1, wherein each R_2 independently is hydrogen, carboxymethyl, or C_2 ~ C_{12} acyl.

6. The hollow sphere from amphiphilic chitosan derivatives as claimed in claim 1, wherein the chitosan derivatives are compounds represented by the following formula (II),

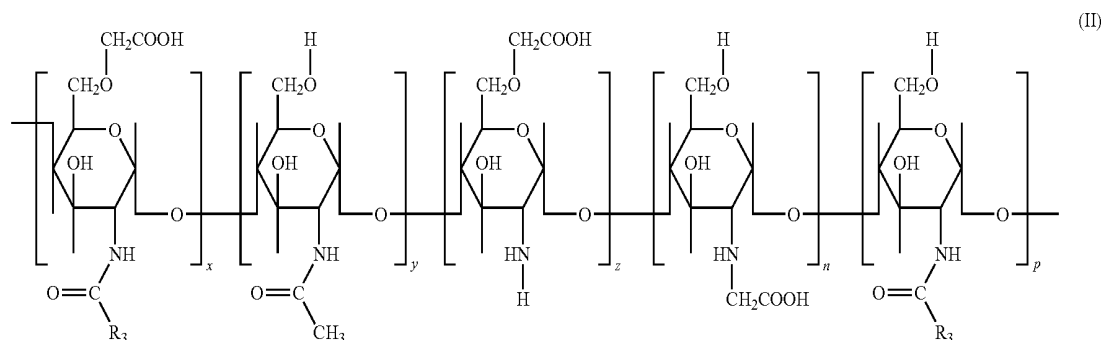

that many other possible modifications and variations can be made without departing from the scope of the invention as hereinafter claimed.

What is claimed is:

1. A hollow sphere from amphiphilic chitosan derivatives, comprising:

chitosan derivatives represented by the following formula (I), which self-assemble and form a hollow sphere in a solvent;

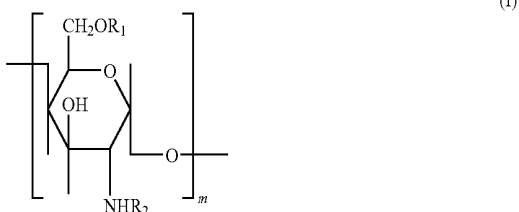

wherein, each R_1 independently is hydrogen, C_1 ~ C_4 alkyl, C_1 ~ C_6 carboxyalkyl, sulfate, or phosphate; each R_2 independently is hydrogen, C_1 ~ C_{12} alkyl, C_1 ~ C_6 carboxyalkyl, or C_2 ~ C_{12} acyl; and m is an integral of 100~2000.

2. The hollow sphere from amphiphilic chitosan derivatives as claimed in claim 1, wherein each R_1 independently is

wherein, each R_3 independently is C_5 ~ C_{11} alkyl; and x , y , z , n , and p independently are integrals of 20~2000.

7. The hollow sphere from amphiphilic chitosan derivatives as claimed in claim 1, wherein the hollow sphere has a mean size of 10~500 nm.

8. A method of preparing an amphiphilic chitosan derivative complex for medical use, comprising following steps:

- providing a chitosan, and substituting at least one hydrophilic group, and at least one hydrophobic group on the chitosan to obtain chitosan derivatives;
- dissolving the chitosan derivatives in a solvent to obtain a solution of the chitosan derivatives; and
- mixing the solution of the chitosan derivatives, and active components, to form hollow spheres through the self-assembling of the chitosan derivatives, wherein the active components are encapsulated inside the hollow spheres.

9. The preparing method as claimed in claim 8, wherein the chitosan has the molecular weight of 1000~400,000 g/mol.

10. The preparing method as claimed in claim 8, wherein the deacetylation degree of the chitosan is 65~100%.

11. The preparing method as claimed in claim 8, wherein the hydrophilic group is selected from the group consisting of carboxymethyl, carboxyl, sulfate, phosphate, trimethyl, and succinyl.

12. The preparing method as claimed in claim 8, wherein the hydrophobic group is selected from the group consisting of C_1 ~ C_{12} alkyl, C_2 ~ C_{12} acyl, tosyl, phthaloyl, or silyl.

13. The preparing method as claimed in claim 8, wherein the substitution degree of the hydrophobic group is 5~100%.

14. The preparing method as claimed in claim 8, wherein the chitosan derivatives are compounds represented by the following formula (I),

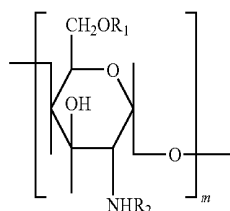

(I)

wherein, each R_1 independently is hydrogen, $C_1\sim C_4$ alkyl, $C_1\sim C_6$ carboxyalkyl, sulfate, or phosphate; each R_2

independently is hydrogen, $C_1\sim C_{12}$ alkyl, $C_1\sim C_6$ carboxyalkyl, or $C_2\sim C_{12}$ acyl; and m is an integral of 100~2000.

15. The preparing method as claimed in claim 14, wherein each R_1 independently is hydrogen, carboxymethyl, carboxyl, sulfate, phosphate, trimethyl, or succinyl.

16. The preparing method as claimed in claim 14, wherein each R_1 independently is hydrogen, or carboxymethyl.

17. The preparing method as claimed in claim 14, wherein each R_2 independently is hydrogen, $C_1\sim C_{12}$ alkyl, $C_1\sim C_6$ carboxyalkyl, $C_2\sim C_{12}$ acyl, tosyl, phthaloyl, or silyl.

18. The preparing method as claimed in claim 14, wherein each R_2 independently is hydrogen, carboxymethyl, or $C_2\sim C_{12}$ acyl.

19. The preparing method as claimed in claim 14, wherein the chitosan derivatives are compounds represented by the following formula (II),

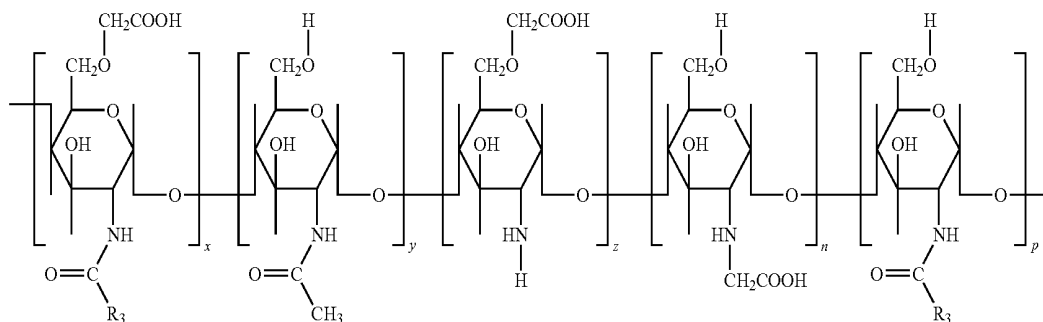

(II)

wherein, each R_3 independently is $C_5\sim C_{11}$ alkyl; and x , y , z , n , and p independently are integrals of 20~2000.

20. The preparing method as claimed in claim 8, wherein the hollow sphere has a mean size of 10-500 nm.

* * * * *