



US 20090303560A1

(19) **United States**

(12) **Patent Application Publication**
Sun et al.

(10) **Pub. No.: US 2009/0303560 A1**

(43) **Pub. Date: Dec. 10, 2009**

(54) **SPATIAL LIGHT MODULATOR**

(30) **Foreign Application Priority Data**

(75) Inventors: **Ching-Cherng Sun**, Hsinchu (TW);
Yeh-Wei Yu, Hsinchu (TW);
Shu-Ching Hsieh, Hsinchu (TW)

Jun. 6, 2008 (TW) 97121204

Publication Classification

Correspondence Address:
Cooper Legal Group LLC
6505 Rockside Road, Suite 330
Independence, OH 44131 (US)

(51) **Int. Cl.**
G03H 1/12 (2006.01)

(52) **U.S. Cl.** **359/11**

(57) **ABSTRACT**

(73) Assignee: **National Chiao Tung University**,
Hsinchu (TW)

A spatial light modulator applied to the collinear volume holographic storage system uses a hollow phase modulator to modulate the surrounding portion of an incident light to be a reference light, and the center portion of the incident light is modulated by a strength modulator to be a signal light. Thus, the spatial light modulator can enhance the convergence of the point spread function of the system.

(21) Appl. No.: **12/172,418**

(22) Filed: **Jul. 14, 2008**

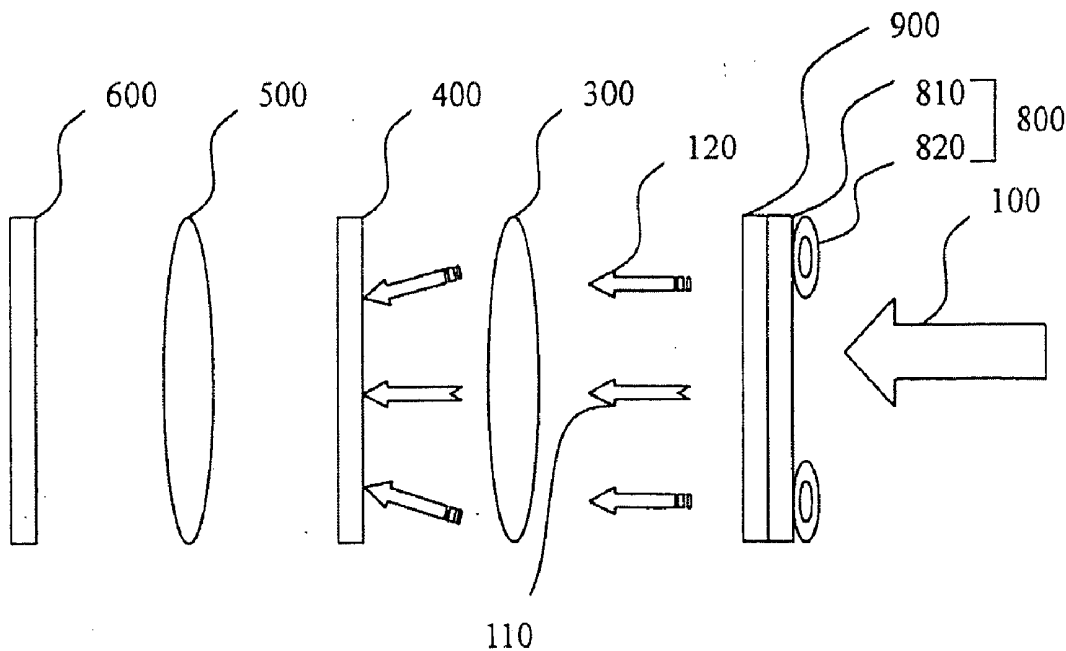

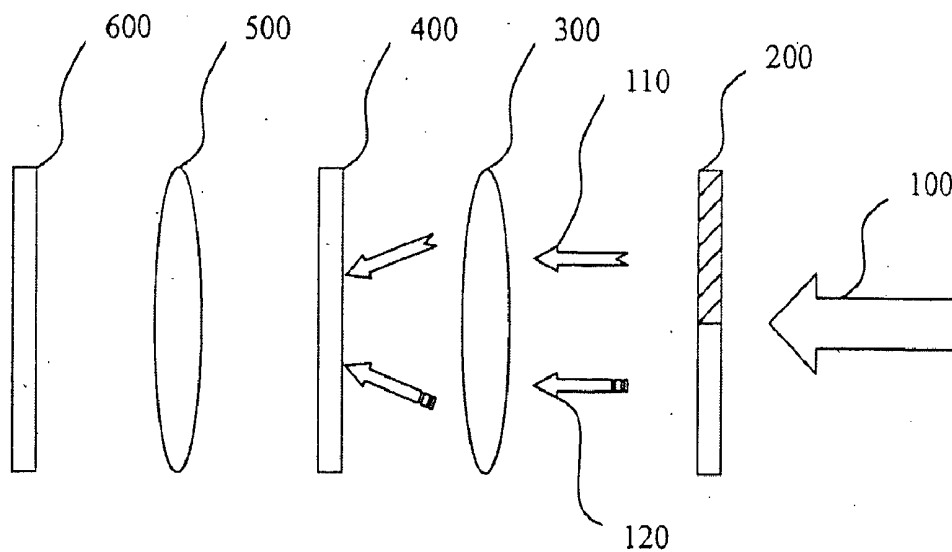

FIG. 1a (PRIOR ART)

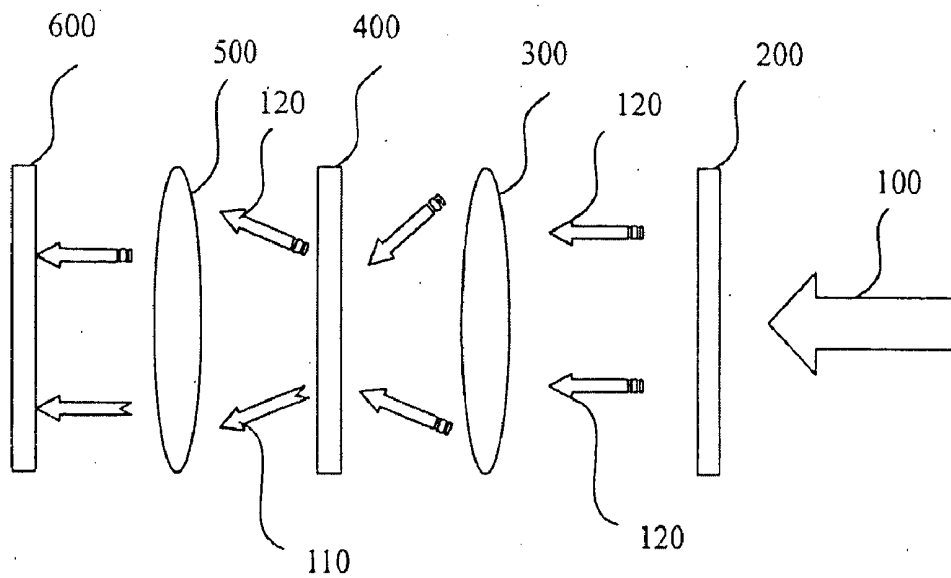

FIG. 1b (PRIOR ART)

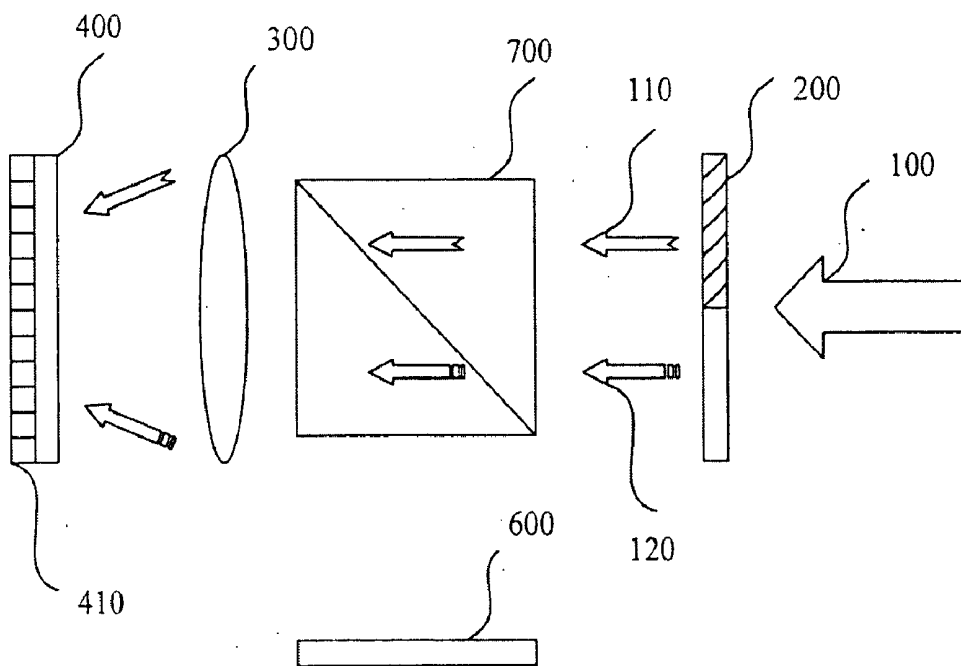

FIG. 2a(PRIOR ART)

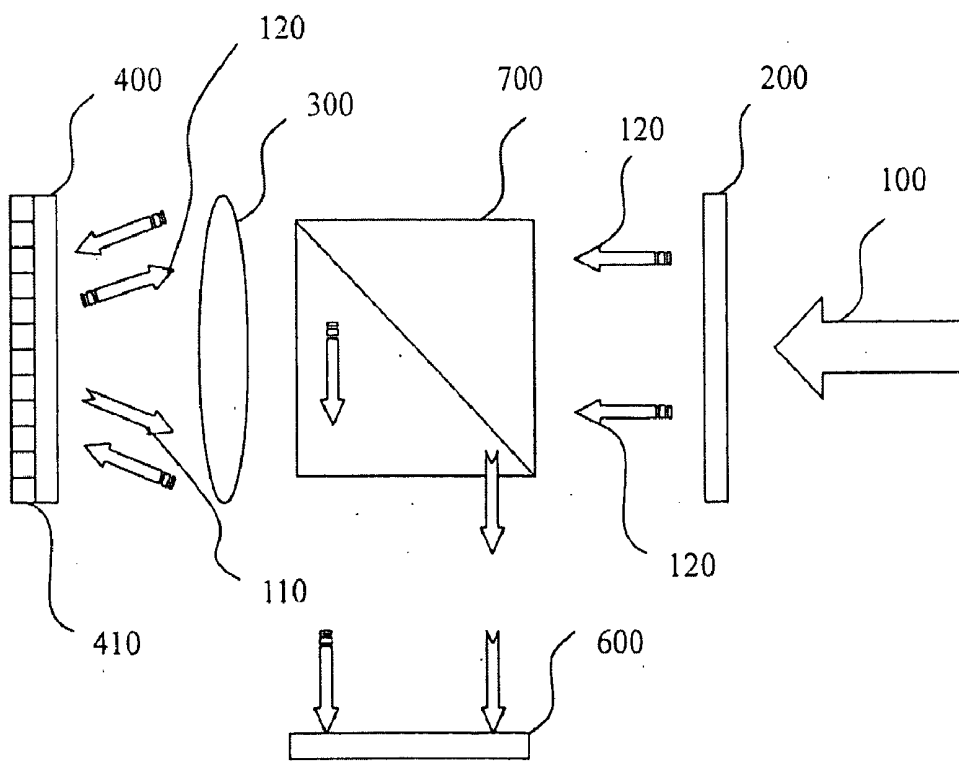

FIG. 2b(PRIOR ART)

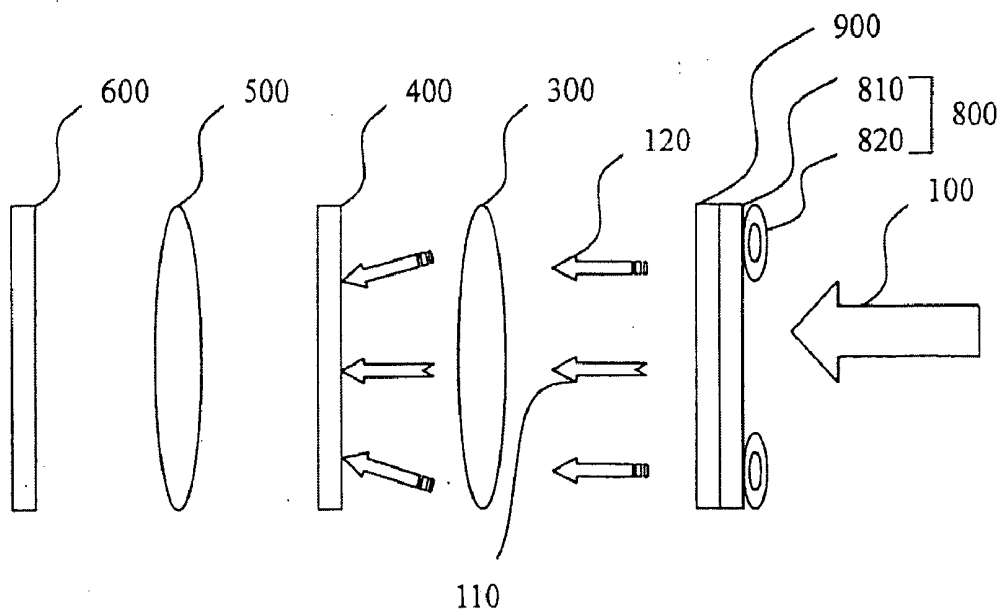

FIG. 3a

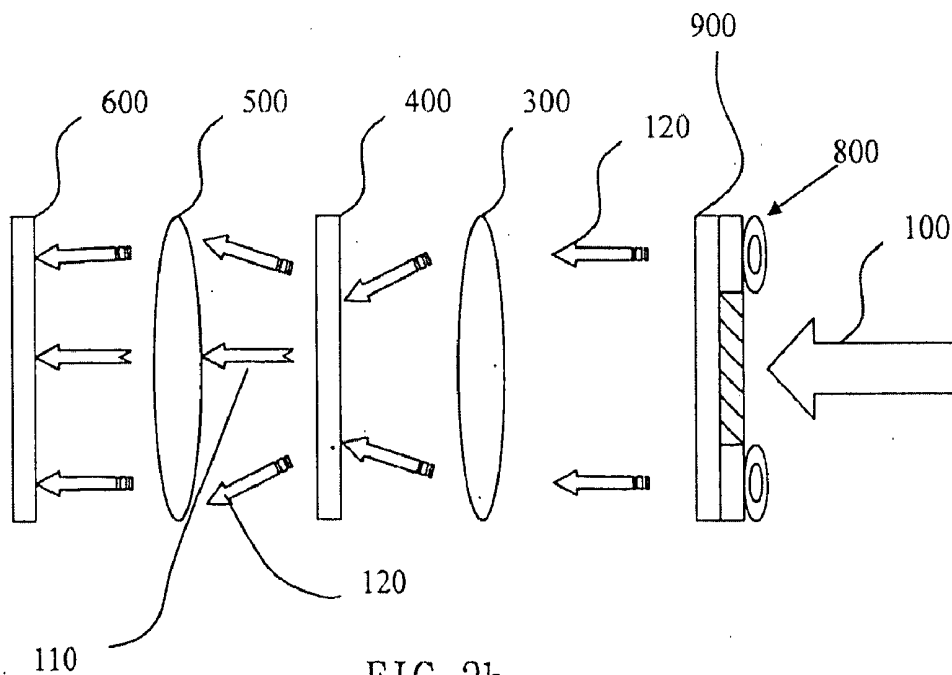

FIG. 3b

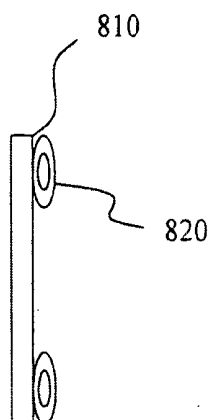

FIG. 4a

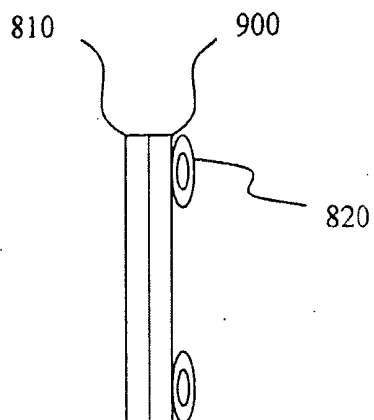

FIG. 4b

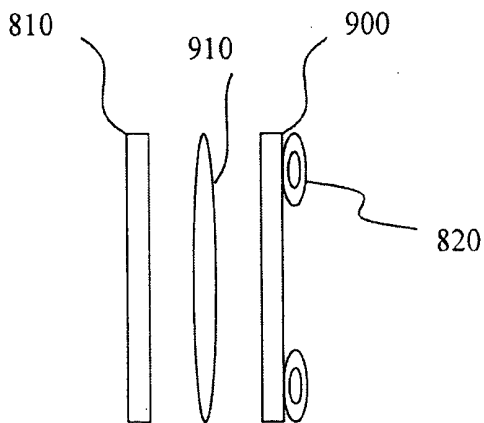

FIG. 4c

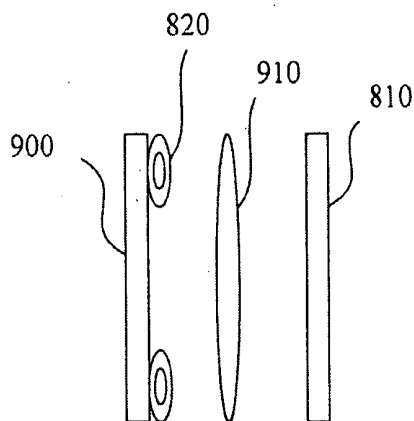

FIG. 4d

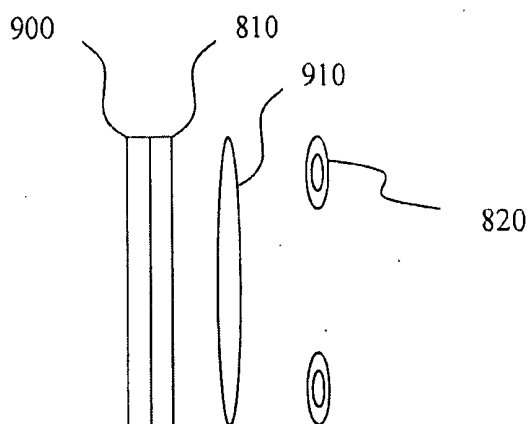

FIG. 4e

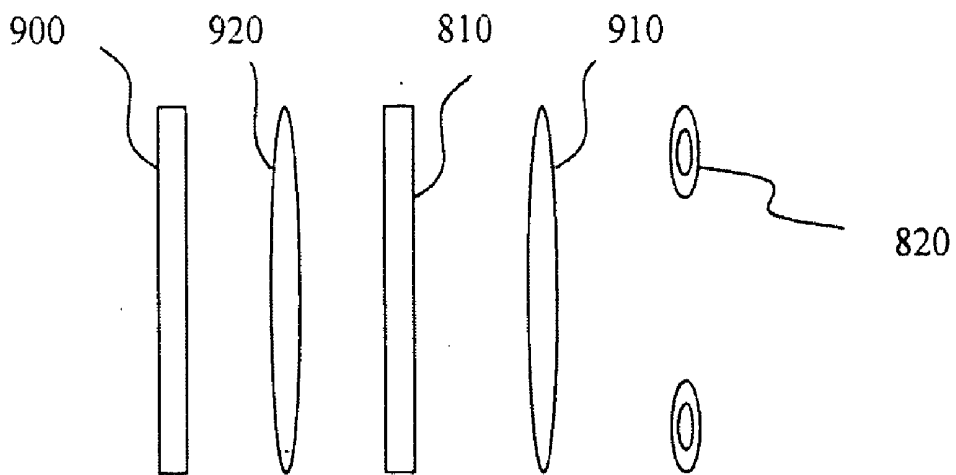

FIG. 4f

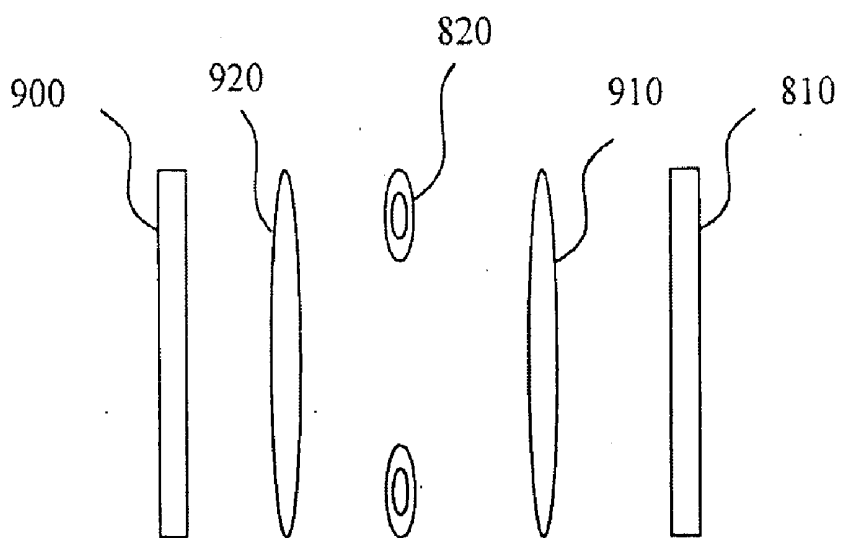

FIG. 4g

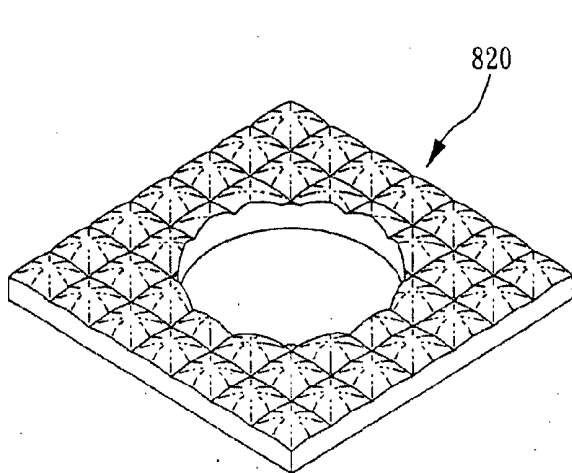

FIG. 5a

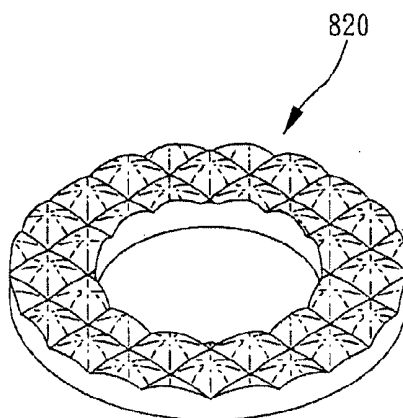

FIG. 5b

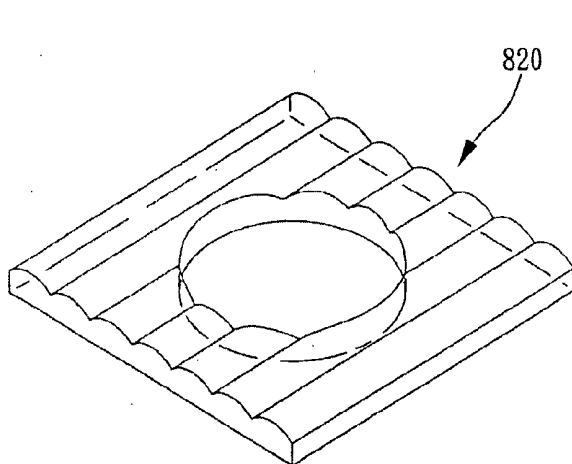

FIG. 5c

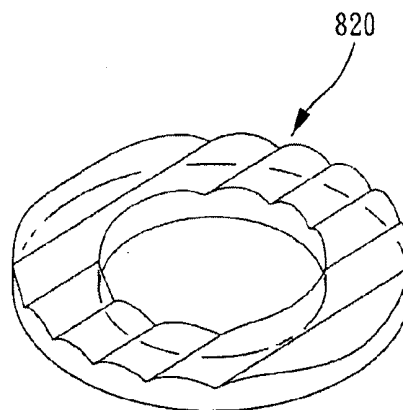

FIG. 5d

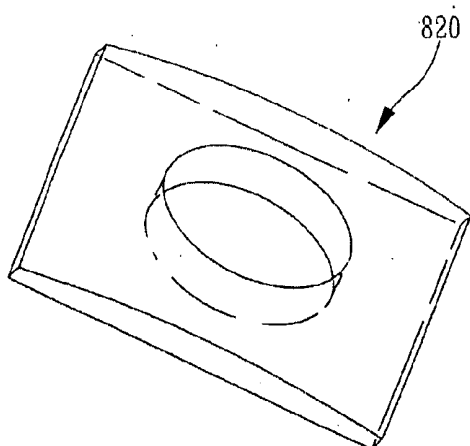

FIG. 5e

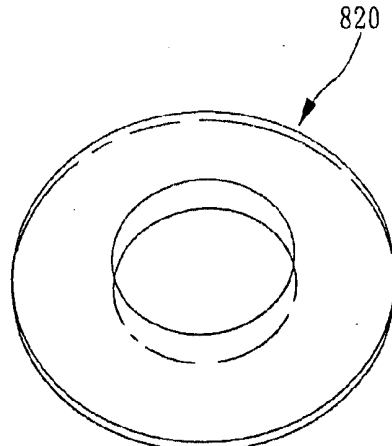

FIG. 5f

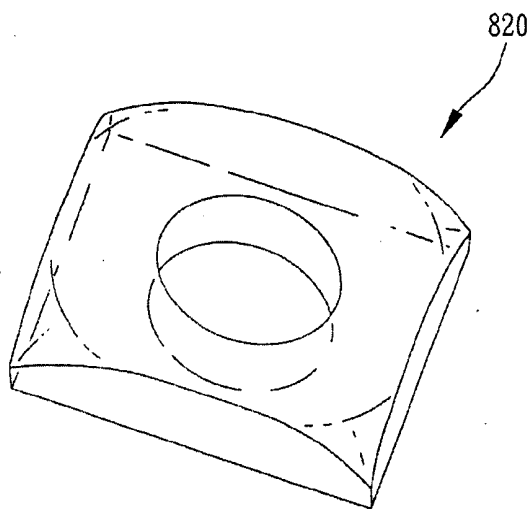

FIG. 5g

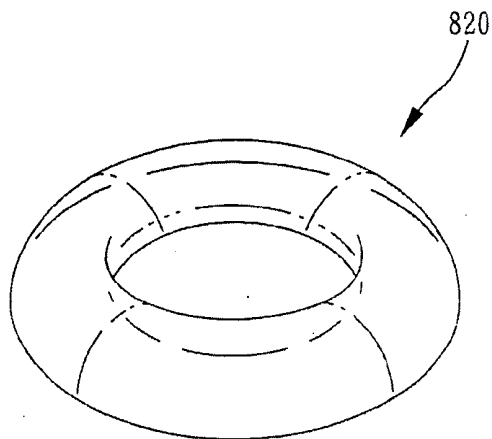

FIG. 5h

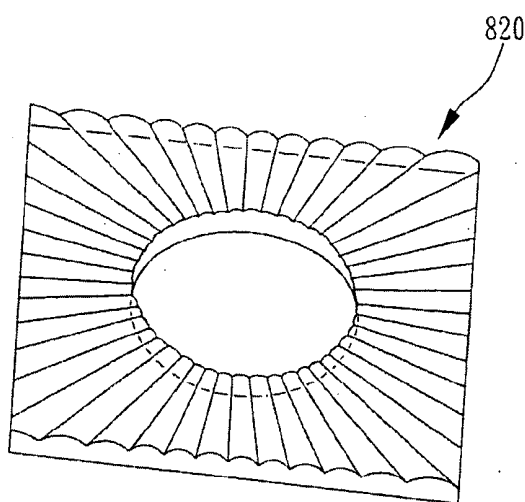

FIG. 5i

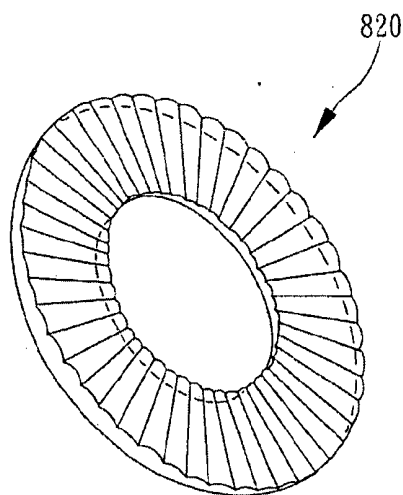

FIG. 5j

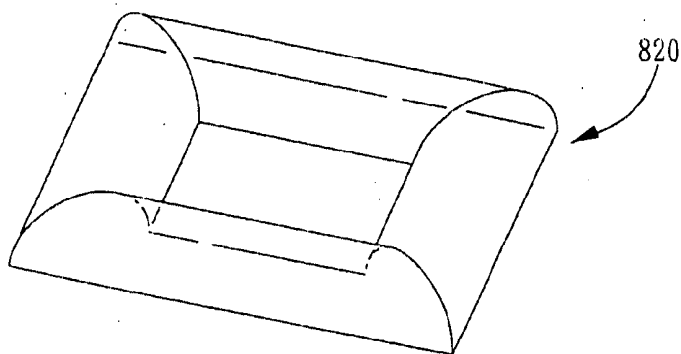

FIG. 5k

SPATIAL LIGHT MODULATOR

BACKGROUND OF THE INVENTION

[0001] 1. Field of the Invention

[0002] This invention relates to a spatial light modulator applied to a collinear volume holographic storage system, and, especially, to a spatial light modulator that can enhance the convergence of the point spread function of this system.

[0003] 2. Description of the Prior Art

[0004] The collinear holographic storage system is the main development in these years, since the collinear holographic technique has the features of high stability, high reliability and high miniaturability.

[0005] In the writing process, the collinear holographic storage system uses a spatial light modulator to generate a signal light and a reference light as a laser light passes the spatial light modulator. After the signal light and the reference light pass a phase modulating mask, the interference will be focused by a lens and recorded homogeneously on a recording medium. In the reading process, the laser light is modulated to a reference light and irradiates on the recording medium to restore the signal via the recorded interference. Finally, the restored light irradiates on a photo-detector and can be read.

[0006] FIG. 1*a* is employed to illustrate the light path of the system in the writing process. The spatial light modulator 200 modulates the incident light 100 to a signal light 110 and a reference light 120, and a lens 300 focus the interference of the signal light 110 and the reference light 120 on a recording medium 400 to be recorded.

[0007] FIG. 1*b* is employed to illustrate the light path of the system in the reading process. The spatial light modulator 200 modulates the incident light 100 to a reference light 120 only, and, after the reference light 120 passes the lens 300, the reference light 120 irradiates on the recording medium 400 to restore the signal light 110 and the reference light 120 via the recorded interference. The restored interference is focused on and irradiates on a photo-detector 600 and can be read.

[0008] The structure of a reflective holographic storage system is different from the transmissive system, abovementioned system, but in the similar theory. The rear face of the recording medium 400 is coated with a reflective material 410, and a splitter 700 is set in the light path. In the writing process, the signal light 110 and the reference light 120 pass the splitter 700 and lens 300 to irradiate on the recording medium 400. In the reading process, the reference light 120 is reflected by the reflective material 410 after passing the splitter 700 and lens 300 to restore the interference. The restored interference passes the splitter 700 and will be reflected to a photo-detector 600 for reading. The light paths in the writing process and reading process are shown in FIG. 2*a* and FIG. 2*b*.

[0009] The above mentioned spatial light modulator has a disadvantage of poor convergence of the point spread function.

SUMMARY OF THE INVENTION

[0010] It is an object to provide a spatial light modulator for improving the convergence of the point spread function. The mean is to set a phase modulator surrounding an amplitude modulator.

[0011] In the writing process, the spatial light modulator modulates the surrounding portion of the incident light to a

reference light and the center portion to a signal light. In reading, the center part of the spatial light modulator is blocked for avoiding generating the signal light, and the reference light will irradiate on the recording medium to restore the recorded interference.

BRIEF DESCRIPTION OF THE DRAWINGS

[0012] FIG. 1*a* and FIG. 1*b* show the light paths of a transmissive holographic storage system of a prior art in the writing and reading process, respectively.

[0013] FIG. 2*a* and FIG. 2*b* show the light paths of a reflective holographic storage system of a prior art in the writing and reading process, respectively.

[0014] FIG. 3*a* and FIG. 3*b* show the light paths of a transmissive holographic storage system employing a spatial light modulator according to an embodiment of this invention in the writing and reading process, respectively.

[0015] FIG. 4*a*-4*g* show spatial light modulators according to the preferred embodiments of this invention.

[0016] FIG. 5*a*-5*k* show phase modulators according to the preferred embodiments of this invention.

DESCRIPTION OF THE PREFERRED EMBODIMENT

[0017] Spatial light modulator includes a strength modulator and a phase modulator with a hollow, and the strength modulator and the phase modulator can be arranged in compact or in separation. The surrounding portion of an incident light is modulated into a reference light by the phase modulator and the center portion to a signal light by the strength modulator. The interference of the reference light and the signal light will be recorded on a recording medium after passing a phase modulating mask. Accompanying with FIG. 3*a* and FIG. 3*b*, the description of the light paths of the transmissive holographic storage system is following.

[0018] In the writing process, as FIG. 3*a*, a hollow phase modulator 820 is adhered to a strength modulator 810 to form a spatial light modulator 800, and a phase modulating mask 900 is adhered to the spatial light modulator 800. The incident light 100 passes the spatial light modulator 800 and the phase modulating mask 900 to form a reference light 120 on the surrounding part of the spatial light modulator 800 and to form a signal light 110 in the center part. The interference of the reference light 120 and the signal light 110 is recorded on a recording medium 400 after passing a lens 300.

[0019] In the reading process, as FIG. 3*b*, the center part of the spatial light modulator 800 is covered. The incident light 100 can not pass the center part of the spatial light modulator 800, and the surrounding portion of the incident light 100 is modulated to a reference light 120 after passing the spatial light modulator 800 and the phase modulating mask 900. The reference light 120 irradiates on the recording medium 400 after the reference light 120 passes the lens 300 to restore the signal light 110, and the restored signal light 110 will pass a second lens 500 to be detected by a photo-detector 600.

[0020] Reflective holographic storage system works in a similar way to the transmissive holographic storage system so the detailed description is omitted here except for the difference. The difference between these two systems is that the former has a reflective material coated on the rear face of the recording medium, a splitter is set in the light path and the second lens (the second lens 500 in previous embodiment)

can be omitted. The splitter will guide the restored interference light to the photo-detector.

[0021] The phase modulator and the strength modulator of the spatial light modulator can be set in compact or in separation, and even more, the phase modulator and the strength modulator can be set in interlace between the other optical components of the system. The preferred embodiments are showing in FIG. 4a-FIG. 4h.

[0022] FIG. 4a shows an embodiment, where the phase modulator 820 is adhered to a strength modulator 810. FIG. 4b shows another embodiment, where the phase modulator 810 and the strength modulator 810 clip the phase modulating mask 900.

[0023] For the embodiments of FIG. 4c and FIG. 4d, the phase modulator 820 is adhered to the phase modulating mask 900 and separated from the strength modulator 810, and a lens 910 is placed in between them. No specific order is required for these optical components.

[0024] For the embodiment of FIG. 4e, the strength modulator 820 is adhered to the phase modulating mask and separated from the phase modulator 810, and a lens 910 is placed in between them. No specific order is required for these optical components.

[0025] For the embodiments of FIG. 4f and FIG. 4g, the phase modulator 820, the strength modulator 810 and the phase modulating mask 900 are separated from each other totally. Lenses 910, 920 are placed in between two components thereof. No specific order is required for these components.

[0026] The phase modulators 802 in abovementioned embodiments can be made from a lens with a hollow. The FIG. 5a-FIG. 5k are the preferred embodiments of the phase modulator according to this invention.

[0027] FIG. 5a and FIG. 5b are a recto-ring-like and a circle-ring-like array of spherical lens with a hollow, respectively. FIG. 5c and FIG. 5d are a recto-ring-like and a circle-ring-like array of pillar lens with a hollow, respectively. FIG. 5e and FIG. 5f are recto-ring-like and circle-ring-like lenses with a hollow, respectively. FIG. 5g and FIG. 5h are recto-ring and circle-ring lenses with a hollow, respectively. FIG. 5i and FIG. 5j are recto-ring-like and circle-ring-like loop array of coned lenses with a hollow, respectively. FIG. 5k is recto array of pillar lenses with a hollow.

[0028] Although this invention has been explained in relation to its preferred embodiment, it is to be understood that

modifications and variation can be made without departing the spirit and scope of the invention as claimed.

What is claimed is:

1. A spatial light modulator, applied to a collinear volume holographic storage system, comprising a strength modulator and a phase modulator with a hollow, wherein said phase modulator is set corresponding to said strength modulator, and said phase modulator modulates a surrounding portion of an incident light to a reference light and said strength modulator modulates the center portion of said incident light to a signal light.

2. A spatial light modulator according to claim 1, wherein said phase modulator is a recto-ring-like or a circle-ring-like array of spherical lens with a hollow.

3. A spatial light modulator according to claim 1, wherein said phase modulator is a recto-ring-like or a circle-ring-like array of pillar lens with a hollow.

4. A spatial light modulator according to claim 1, wherein said phase modulator is a recto-ring-like or circle-ring-like lens with a hollow.

5. A spatial light modulator according to claim 1, wherein said phase modulator is a recto-ring-like or circle-ring-like loop array of coned lenses with a hollow.

6. A spatial light modulator according to claim 1, wherein said phase modulator is a recto array of pillar lenses with a hollow.

7. A spatial light modulator according to claim 1, wherein said phase modulator with a hollow, is adhered to said strength modulator.

8. A spatial light modulator according to claim 1, wherein said phase modulator, with a hollow, and said strength modulator are adhered to both sides of a phase modulating mask.

9. A spatial light modulator according to claim 1, wherein said phase modulator, with a hollow, is adhered to a phase modulating mask and separated from said strength modulator with a space, and a lens is placed in said space.

10. A spatial light modulator according to claim 1, wherein said strength modulator is adhered to a phase modulating mask and separated from said phase modulator with a hollow, with a space, and a lens is placed in said space.

11. A spatial light modulator according to claim 1, wherein said strength modulator, said phase modulator, with a hollow, and a phase modulating mask are separated from each other with a space and a lens is set in each space of two components thereof.

* * * * *