



US 20090161399A1

(19) **United States**

(12) **Patent Application Publication**
Huang et al.

(10) **Pub. No.: US 2009/0161399 A1**
(43) **Pub. Date: Jun. 25, 2009**

(54) **SUPER LEAKAGE CURRENT CUT-OFF
DEVICE FOR TERNARY CONTENT
ADDRESSABLE MEMORY**

(30) **Foreign Application Priority Data**

Dec. 25, 2007 (TW) 96149999

(76) Inventors: **Po-Tsang Huang**, Hsinchu (TW);
Wen-Yen Liu, Hsinchu (TW); **Wei
Hwang**, Salamanca La Verna, CA
(US)

Publication Classification

(51) **Int. Cl.**
G11C 15/00 (2006.01)
G11C 5/14 (2006.01)
(52) **U.S. Cl.** **365/49.1; 365/226**

Correspondence Address:
ROSENBERG, KLEIN & LEE
3458 ELLICOTT CENTER DRIVE-SUITE 101
ELLICOTT CITY, MD 21043 (US)

(57) **ABSTRACT**

A super leakage current cut-off device for a ternary content addressable memory (TCAM) is provided. For various operations of the TCAM, the device uses the high-end and low-end power gating control transistors to turn on/off the don't-care cells to reduce the leakage current passing through the don't-care cells.

(21) Appl. No.: **12/007,824**

(22) Filed: **Jan. 16, 2008**

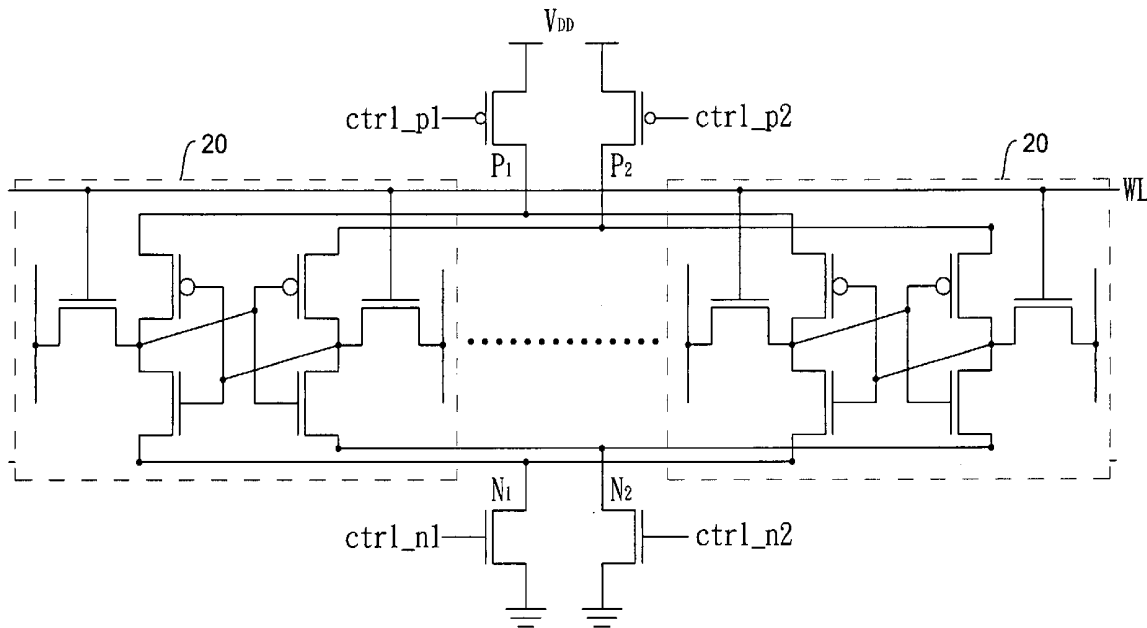

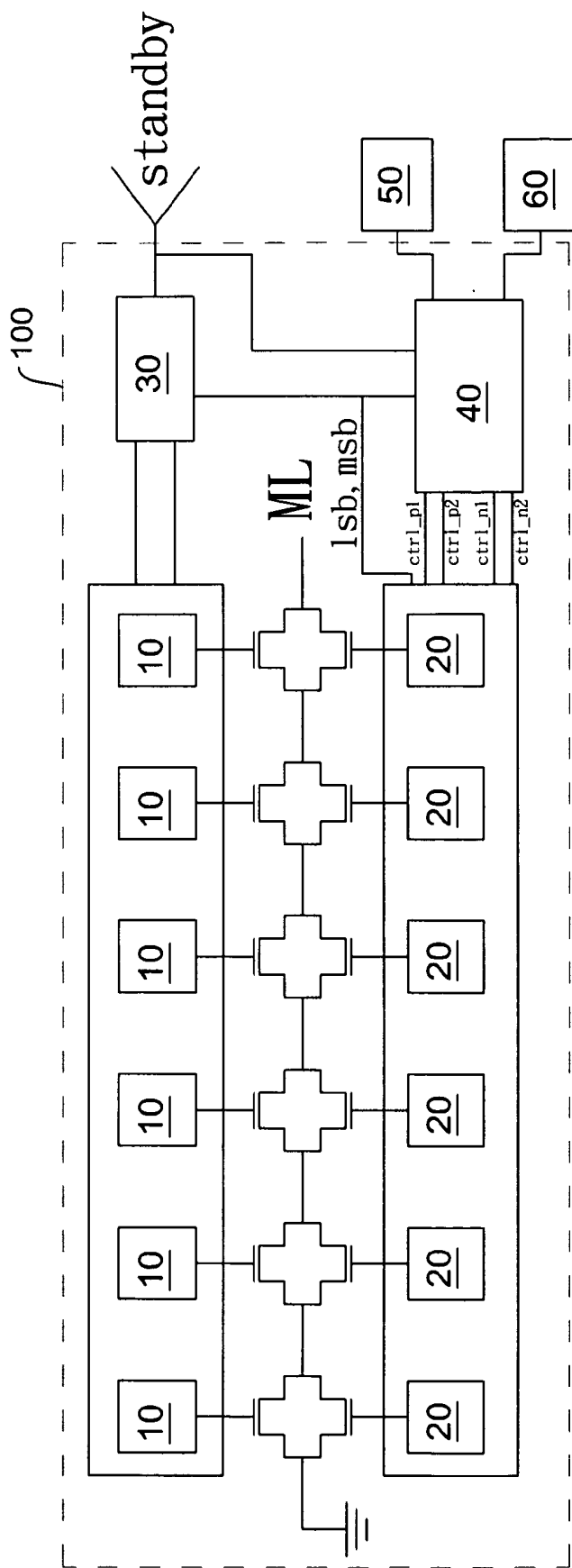

Fig. 1

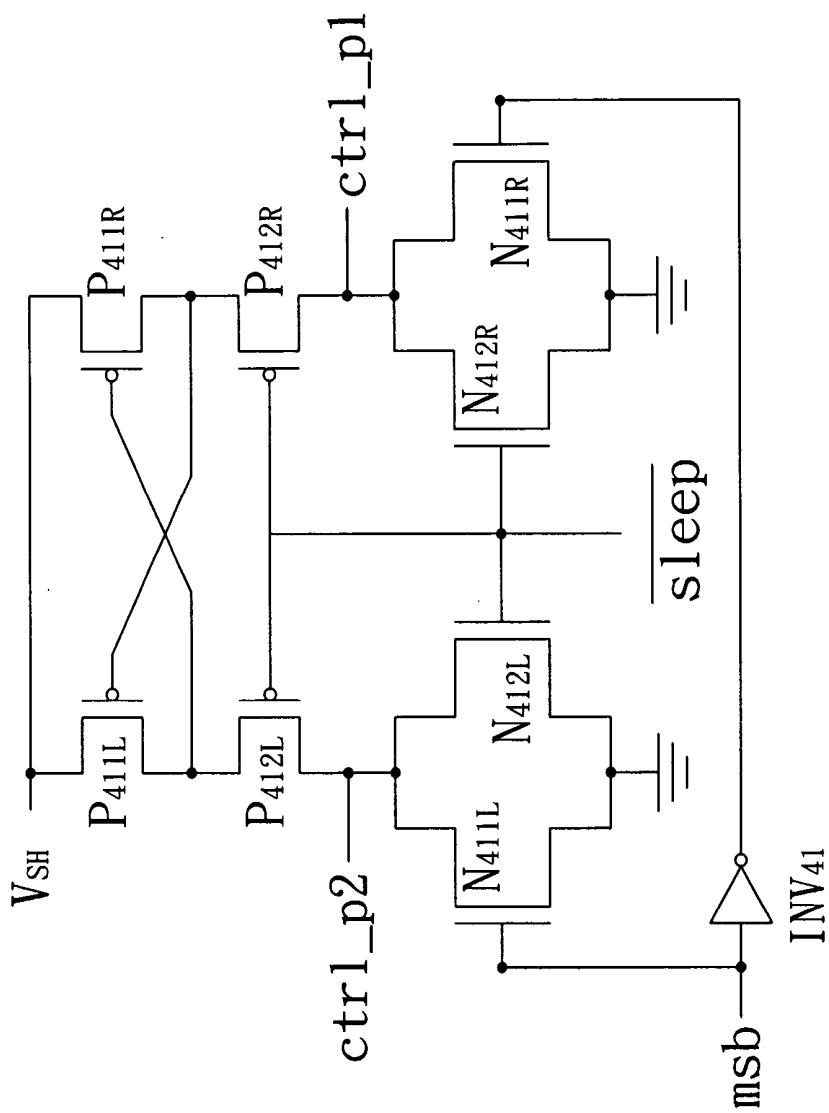

Fig. 3

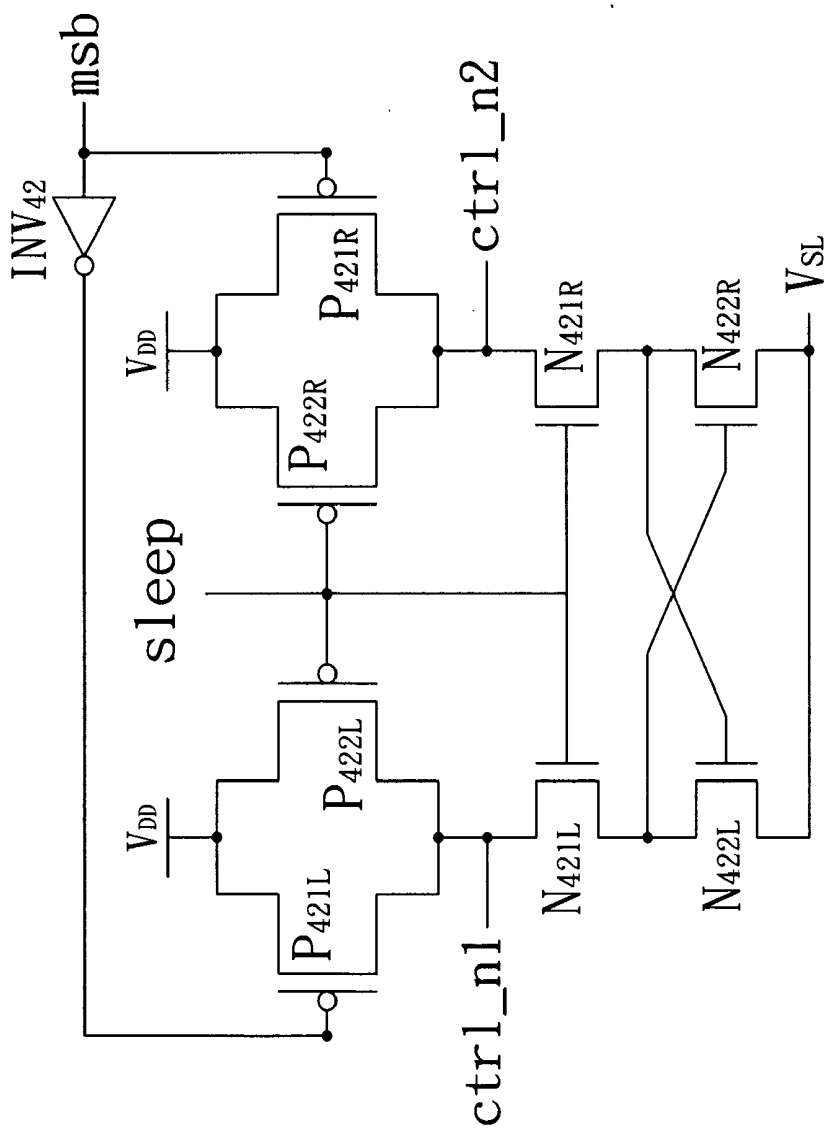

Fig. 4

SUPER LEAKAGE CURRENT CUT-OFF DEVICE FOR TERNARY CONTENT ADDRESSABLE MEMORY

BACKGROUND OF THE INVENTION

[0001] 1. Field of the Invention

[0002] The present invention relates to a super leakage current cut-off device for a ternary content addressable memory.

[0003] 2. Description of the Prior Art

[0004] A Ternary Content Addressable Memory (TCAM) is grouped into several array segments, and each segment includes an array of TCAM cell pairs. Each TCAM cell pair is a bit that includes a storage cell and a don't-care cell, and a cell has an inverter pair of two cascading inverters. Each bit may be in a "0" state, an "1" state or an "X" state that is also called don't-care state.

[0005] The charging terminal and discharging terminal of the don't-care cell connect respectively an electrical power source and the ground, so a leakage current through the don't-care cell is accompanied. The smaller the microelectric circuit scale approaches, the more serious the power consumption of leakage current is, and moreover it damages the reliability of the microelectric circuit. Therefore, the invention proposes a solution of reducing the leakage current for the don't-care cell of a TCAM.

SUMMARY OF THE INVENTION

[0006] The invention provides a super leakage current cut-off device to reduce the leakage current through the don't-care cell of the TCAM. A super cut-off power gating control apparatus uses two high-end power gating transistors connected to between the charging terminal of the inverter pairs of the don't-care cells in a segment and the power source with voltage V_{DD} and two low-end power gating transistors between the discharging terminal and the ground. The high-end and the low-end power gating transistors can be controlled respectively by the high-end and low-end gate voltage to form a zigzag cut-off control circuit to reduce the leakage current.

[0007] Further, the high-end or low-end gate transistors can be turned off by imposing the super cut-off voltage on the gate electrode of the high-end and low-end gate transistors to stress the leakage current more. That is called super cut-off power gating control circuit.

BRIEF DESCRIPTION OF THE DRAWINGS

[0008] The foregoing aspects and many of the accompanying advantages of this invention will become more readily appreciated as the same becomes better understood by reference to the following detailed description, when taken in conjunction with the accompanying drawings, wherein:

[0009] FIG. 1 is a schematic diagram showing the structure of TCAM according to one embodiment of the present invention;

[0010] FIG. 2 is a diagram showing the connection of the super cut-off power gating control circuit to a TCAM segment of the don't-care cells according to one embodiment of the present invention;

[0011] FIG. 3 is a diagram showing the controller circuit of the high-end control voltage signal according to one embodiment of the present invention; and

[0012] FIG. 4, is a diagram showing the controller circuit of the low-end control voltage signal according to one embodiment of the present invention;

DESCRIPTION OF THE PREFERRED EMBODIMENT

[0013] The detailed explanation of the present invention is described as following. The described preferred embodiments are presented for purposes of illustrations and description, and they are not intended to limit the scope of the present invention.

[0014] A ternary content addressable memory (TCAM) is grouped into several segments, and the schematic circuit of a segment is shown in FIG. 1 as an explanation example. In this embodiment, one segment **100** includes six bits, and the storage cell **10** and don't-care cell **20** of a bit are connected to the match line (ML) by NMOSs. In a TCAM segment, each storage cell **10** connects to the multi-mode power gating control apparatus **30** to reduce the leakage current through the storage cell **10**, and each don't-care cell **20** to the super cut-off power gating control circuit **40** to reduce the leakage current through the don't-care cell **20**.

[0015] The multi-mode power gating control apparatus **30** is disclosed in a Taiwan patent application TW96149397, and the super cut-off power gating control circuit **40** is disclosed here.

[0016] As shown in figure, the don't-care cells of each segment **100** use a super cut-off power gating control circuit **40**, and connect an external voltage doubler **50** and an external super cut-off voltage generator **60** to reduce the leakage current through don't-care cells **20**. The voltage doubler **50** and the super cut-off voltage generator **60** are employed to provide positive super cut-off voltage V_{SH} and negative super cut-off voltage V_{SL} , respectively.

[0017] The super cut-off power gating control circuit **40** receives the storage value msb of the first bit of a don't-care cell **20**, the storage value lsb of the final bit of the don't-care cell **20** and standby signal to control first high-end control voltage signal ctrl_p1, second high-end control voltage signal ctrl_p2, first low-end control voltage signal ctrl_n1 and second low-end control voltage signal ctrl_n2 to reduce the leakage current through don't-care cell **20**.

[0018] Refer to FIG. 2, which show the how the high-end and the low-end power gating transistors of a super cut-off power gating control circuit **40** connect to the don't-care cell **20**. The don't-care cell **20** includes an inverter pair including a left inverter and a right inverter. Instead of directly connecting to the voltage source with voltage V_{DD} , the charging terminals of the inverters are firstly connected to the first high-end power gating transistor P_1 and the second high-end power gating transistor P_2 , then to V_{DD} , that forms the first virtual charging terminal and the second virtual charging terminal, respectively. Similarly, the discharging terminals of the inverters are firstly connected to the first low-end power gating transistor N_1 and the second low-end power gating transistor N_2 , then to the ground to form the first virtual ground and the second virtual ground, respectively. The "left" and "right" indicate the connectionship but real position in space.

[0019] In this embodiment, the high-end power gating transistors P_1 and P_2 are p-channel metal oxide semiconductor field effect transistors (PMOSs). The source electrodes of P_1 and P_2 connect to V_{DD} , and the drain electrodes of P_1 and P_2 to the discharging terminals of the left inverter and the right

inverter of the don't-care cell 20, respectively. And, the gate electrodes of P₁ and P₂ is used to receive ctrl_p1 and ctrl_p2.

[0020] The low-end power gating transistors N₁ and N₂ are n-channel metal oxide semiconductor field effect transistors (NMOSs). The drain electrodes of N₁ and N₂ respectively connect to the discharging terminals of the left inverter and the right inverter of the don't-care cell 20, and the source electrodes of N₁ and N₂ to the ground. And, the gate electrodes of N₁ and N₂ is used to receive ctrl_n1 and ctrl_n2.

[0021] When ctrl_p1 turns on P₁, the N₁ and P₂ are turned off but N₂ on; and when ctrl_p1 turn off P₁, the N₁ and P₂ are turned on but N₂ off, and thus a zigzag cut-off control circuit is formed to reduce the leakage current. P₁, P₂ and N₁, N₂ can be expressed by super cut-off voltages V_{SH} and V_{SL} respectively to further reduce the leakage current when they are turned off. The control circuit of P₁ and P₂ is called high-end voltage signal controller and shown in FIG. 3, and the control circuit of N₁ and N₂ is call low-end voltage signal controller and shown in FIG. 4.

[0022] FIG. 3 shows the circuit of the high-end voltage signal controller. The high-end voltage signal controller includes a first PMOS P_{411L}, a first right PMOS P_{411R}, a second left PMOS P_{412L}, a second right PMOS P_{412R}, a first left NMOS N_{411L}, a first right NMOS N_{411R}, a second left NMOS N_{412L}, a second right NMOS N_{412R} and an inverter INV₄₁. The "left" and "right" indicates the connectionship but real position in space.

[0023] The source electrodes of P_{411L} and P_{411R} are expressed by the V_{SH}. The gate electrode of P_{411L} is connected to the drain electrode of P_{411R}, and the gate electrode P_{411R} to the drain electrode of P_{411L}. The source electrodes of P_{412L} and P_{412R} respectively are connected to the drain electrodes of P_{411L} and P_{411R}, and the gate electrodes of P_{412L} and P_{412R} are coupled together, the interconnected point is expressed by the signal sleep, which means the inverse signal of the signal sleep. The drain electrodes of N_{411L} and N_{411R} respectively connect the drain electrodes of P_{412L} and P_{412R}, and the source electrodes of N_{411L} and N_{411R} are connected to the ground. and the gate electrodes of N_{411L} and N_{411R} are connected through the INV₄₁ and expressed by the signal msb. The drain electrodes of N_{412L} and N_{412R} are coupled receptively to the drain electrodes of N_{411L} and N_{411R}, and the source electrodes of N_{412L} and N_{412R} are coupled receptively to the source electrodes of N_{411L} and N_{411R}, and the gate electrodes of N_{412L} and N_{412R} are coupled together and expressed by the sleep. The drain electrodes of P_{412L} and P_{412R} output receptively the ctrl_p2 and ctrl_p1.

[0024] Continuously, the low-end voltage signal controller is explained by accompanying the FIG. 4. The low-end voltage signal controller includes a first left P_{421L}, a first right P_{421R}, a second left P_{422L}, a second right P_{422R}, a first left N_{421L}, a first right N_{421R}, a second left N_{422L}, a second right N_{422R} and an inverter INV₄₂. The "left" and "right" indicates the connectionship but real position in space.

[0025] The source electrodes of P_{421L} and P_{421R} are connected to voltage V_{DD}, which is 1.2 volt in the embodiment. The source electrodes of P_{421L} and P_{421R} are connected through the INV₄₂ and expressed by the signal msb. The source electrodes of P_{422L} and P_{422R} and the drain electrodes of P_{422L} and P_{422R} are respectively coupled to the source electrodes of P_{421L} and P_{421R} and the drain electrodes P_{421L} and P_{421R}. The gate electrodes of P_{422L} and P_{422R} are coupled together and expressed by the signal sleep. The drain electrodes of N_{421L} and N_{421R} are respectively coupled to the

drain electrodes of P_{421L} and P_{421R}, and the gate electrodes of N_{421L} and N_{421R} are coupled together and expressed by the signal sleep. The drain electrodes of N_{422L} and N_{422R} are respectively coupled to the source electrodes of N_{421L} and N_{421R}, and the source electrodes of N_{422L} and N_{422R} are expressed by the minus voltage V_{SL}, and the gate electrodes of N_{422L} and N_{422R} are inter-connected to the drain electrodes of N_{422R} and N_{422L}. The source electrodes of N_{421L} and N_{421R} output ctrl_n1 and ctrl_n2, respectively.

[0026] Table 1 illustrates the relationship of the signals sleep, msb to ctrl_p1, ctrl_p2, ctrl_n1 and ctrl_n2.

TABLE 1

| sleep | msb | ctrl_p1 | ctrl_p2 | ctrl_n1 | ctrl_n2 |
|-------|-----|-----------------|-----------------|-----------------|-----------------|
| 0 | 1 | 0 | 0 | V _{DD} | V _{DD} |
| 0 | 0 | 0 | 0 | V _{DD} | V _{DD} |
| 1 | 1 | V _{SH} | 0 | V _{DD} | V _{SL} |
| 1 | 0 | 0 | V _{SH} | V _{SL} | V _{DD} |

When sleep=0, the ctrl_p1 and ctrl_p2 are equal to the ground voltage, denoted by 0 in this table and the ctrl_n1 and ctrl_n2 are equal to the high voltage, supplied by the voltage source and denoted by V_{DD}, and the super cut-off power gating control circuit technology is not suitable (means it is not used). When sleep=1, the ctrl_p1, ctrl_p2, ctrl_n1 and ctrl_n2 vary with the signal msb, and it means the technology is suitable for reducing the leakage current. If msb=0, that ctrl_p1=0, ctrl_p2=V_{SH}, ctrl_n2=V_{DD} and ctrl_n1=V_{SL}, and if msb=1, ctrl_p1=V_{SH}, ctrl_p2=0, ctrl_n2=V_{SL}, and ctrl_n1=V_{DD}. In this embodiment, V_{DD}=1.2 volt, V_{SH}=1.5 volt and V_{SL}=-0.3 volt.

[0027] Finally, by accompanying the Table. 2, the suitable operations and mode can be found. Table 2 illustrates the relationship of standby, lsb, msb, and sleep.

TABLE 2

| | msb = lsb = 0 | msb ≠ lsb | msb = lsb = 1 |
|-----------------|---------------|-----------|---------------|
| Write operation | sleep = 0 | sleep = 0 | sleep = 0 |
| Read operation | sleep = 1 | sleep = 0 | sleep = 1 |
| Refer operation | sleep = 1 | sleep = 0 | sleep = 1 |
| Standby mode | sleep = 1 | sleep = 0 | sleep = 1 |

When in write operation or msb≠lsb, sleep=0 represents the not suitable operations or mode; on the contrary, in other operation mode, sleep=1 represents the suitable operations or mode, which can use this art to reduce the leakage current.

[0028] While the invention is susceptible to various modifications and alternative forms, a specific example thereof has been shown in the drawings and is herein described in detail. It should be understood, however, that the invention is not to be limited to the particular form disclosed, but to the contrary, the invention is to cover all modifications, equivalents, and alternatives falling within the spirit and scope of the appended claims.

What is claimed is:

1. A super leakage current cut-off device, applied to a ternary content addressable memory (TCAM), utilizing a super cut-off power gating control circuit to reduce the leakage current through the don't-care cells of said TCAM, wherein said super cut-off power gating control circuit comprises:

- a first high-end power gating transistor connected between a charging terminal of a first inverter of a don't-care cell in said TCAM and a voltage source;
- a second high-end power gating transistor connected between a charging terminal of a second inverter of said don't-care cell in said TCAM and said voltage source;
- a first low-end power gating transistor connected between a discharging terminal of said first inverter of said don't-care cell in said TCAM and the ground; and
- a second low-end power gating transistor connected between a discharging terminal of said second inverter of said don't-care cell in said TCAM and the ground; wherein the gate electrodes of said first high-end power gating transistor, said second high-end power gating transistor, said first low-end power gating transistor and said second low-end power gating transistor respectively are expressed respectively by a first high-end voltage signal, a second high-end voltage signal, a first low-end voltage signal and a second low-end voltage signal to determine turn on/off said first high-end power gating transistor, said second high-end power gating transistor, said first low-end power gating transistor and said second low-end power gating transistor to reduce the leakage current through said don't-care cells in said TCAM according to a switching control signal.
2. The super leakage current cut-off device according to claim 1, further comprising a high-end voltage signal controller, which is connected to a voltage doubler and said don't-care cells of said TCAM to generate said first high-end voltage signal and said second high-end voltage signal.
3. The super leakage current cut-off device according to claim 2, wherein said high-end voltage controller comprises:
- a first left PMOS and a first right PMOS, wherein the source electrodes are connected to said voltage doubler and expressed by a high-end super cut-off voltage providing by said voltage doubler, the source electrode of said first left PMOS is connected to the gate electrode of said first right PMOS and the source electrode of said first right PMOS to the gate electrode of said first left PMOS;
 - a second left PMOS and a second right PMOS, wherein the source electrodes of said second left PMOS and said second right PMOS are respectively connected to the gate electrodes of said first left PMOS and said first right PMOS, and the gate electrodes of said second left PMOS and said second right PMOS are connected together and expressed by said switching control signal;
 - a first left NMOS and a first right NMOS, wherein the drain electrodes of said first left NMOS and said first right NMOS are respectively connected to the drain electrodes of said second left PMOS and said second right PMOS, and the source electrodes of said first left NMOS and said first right NMOS are coupled to the ground, and the gate electrodes of said first left NMOS and said first right NMOS are connected through an inverter and expressed by a storage voltage of the first one of said don't-care cells in said TCAM; and
 - a second left NMOS and a second right NMOS, wherein the drain electrodes of said second left NMOS and said second right NMOS are respectively coupled to the drain electrodes of said first right NMOS and said first right
- NMOS, and the source electrodes of said second left NMOS and said second right NMOS are respectively coupled to the source electrodes of said first left NMOS and said first right NMOS, and the gate electrodes of said second left NMOS and said second right NMOS are coupled together and expressed by said switching control signal.
4. The super leakage current cut-off device according to claim 1, further comprising a low-end voltage signal controller, which is connected to a super cut-off voltage generator and said don't-care cell of TCAM to generate said first low-end control voltage signal and said second low-end control voltage signal.
5. The super leakage current cut-off device according to claim 4, wherein said low-end voltage signal controller comprises:
- a first left PMOS and a first right PMOS, wherein the source electrodes of said first left PMOS and said first right PMOS are connected to a voltage source with a positive voltage, and the gate electrodes of said first left PMOS and said first right PMOS are connected through an inverter and expressed by a storage voltage of the first one of said don't-care cells in said TCAM;
 - a second left PMOS and a second right PMOS, wherein the source electrodes of said second left PMOS and said second right PMOS are respectively connected to the source electrodes of said first left PMOS and said first right PMOS, and the drain electrodes of said second left PMOS and said second right PMOS are respectively connected to the drain electrodes of said first left PMOS and said first right PMOS, and the gate electrodes of said second left PMOS and said second right PMOS are coupled together and expressed by said switching control signal;
 - a first left NMOS and a first right NMOS, wherein the drain electrodes of said first left NMOS and said first right NMOS are respectively connected to the drain electrodes of said first left PMOS and said first right PMOS, and the gate electrodes of said first left NMOS and said first right NMOS are coupled together and expressed by said switching-control signal; and
 - a second left NMOS and a second right NMOS, wherein the drain electrodes of said second left NMOS and said second right NMOS are respectively connected to the source electrodes of first left NMOS and first right NMOS, and the source electrodes of said second left NMOS and said second right NMOS are connected said low-end voltage signal controller, and the gate electrode of said second left NMOS is connected to the drain electrode of said second right NMOS, and the gate electrode of said second right NMOS is connected to the drain electrode of said second left NMOS.
6. The super leakage current cut-off device according to claim 1, wherein said first high-end power gating transistor and said second first high-end power gating transistor are PMOSs.
7. The super leakage current cut-off device according to claim 1, wherein said first low-end power gating transistor and said second first low-end power gating transistor are NMOSs.