



(19) **United States**

(12) **Patent Application Publication**
Chin et al.

(10) **Pub. No.: US 2009/0028042 A1**

(43) **Pub. Date: Jan. 29, 2009**

(54) **SYMBOL TIME SYNCHRONIZATION
METHOD FOR OFDM SYSTEMS**

Publication Classification

(76) Inventors: **Wen-Long Chin, Hsinchu (TW);
Sau-Gee Chen, Hsinchu (TW)**

(51) **Int. Cl.**
H04J 11/00 (2006.01)
H04L 27/28 (2006.01)
(52) **U.S. Cl.** **370/203; 375/260**

Correspondence Address:
ROSENBERG, KLEIN & LEE
3458 ELLICOTT CENTER DRIVE-SUITE 101
ELLICOTT CITY, MD 21043 (US)

(57) **ABSTRACT**

A symbol time synchronization method for OFDM systems is disclosed. The invention presents a joint maximum-likelihood (ML) synchronization method for symbol time offset (STO) for OFDM systems. The method is developed in frequency-domain under time-variant multipath channels. By analyzing the received frequency-domain data, a mathematical model for the joint effects of symbol time offset (STO), carrier frequency offset (CFO) and sampling clock frequency offset (SCFO) is derived. The results are used to formulate a log-likelihood function of two consecutive symbols. The joint estimation's method is robust, because it exhibits high performances in high mobility and time-variant multipath fading channels.

(21) Appl. No.: **12/003,690**

(22) Filed: **Dec. 31, 2007**

(30) **Foreign Application Priority Data**

Jul. 26, 2007 (TW) 96127173

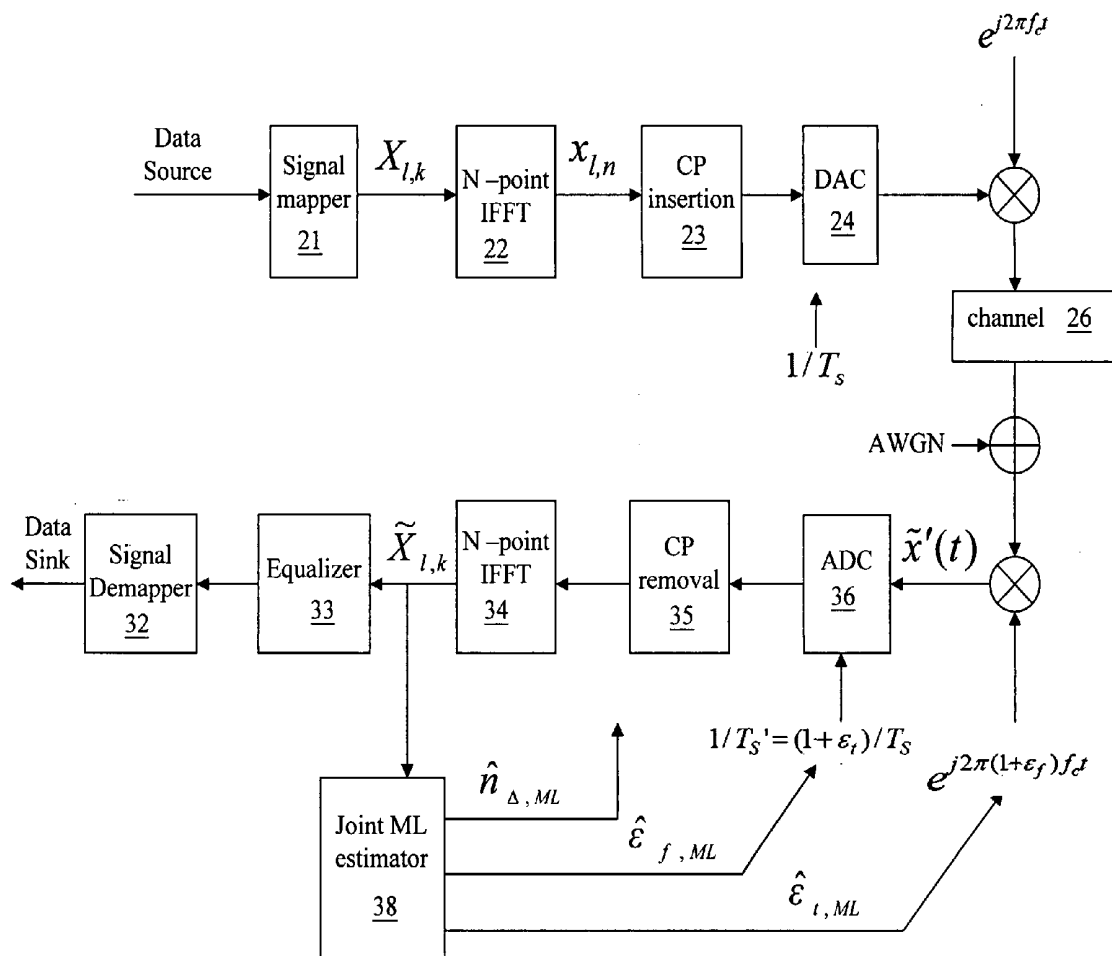

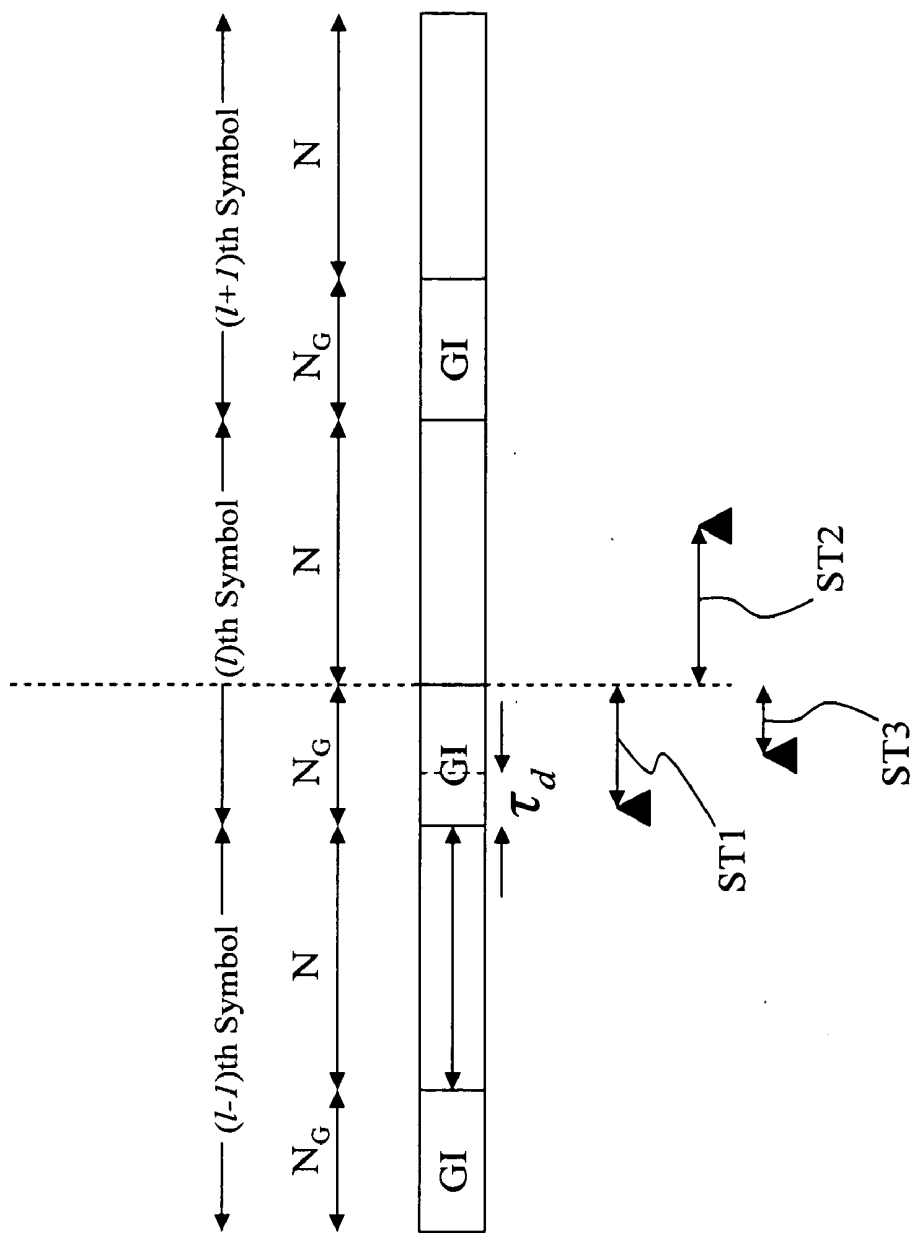

Fig. 1

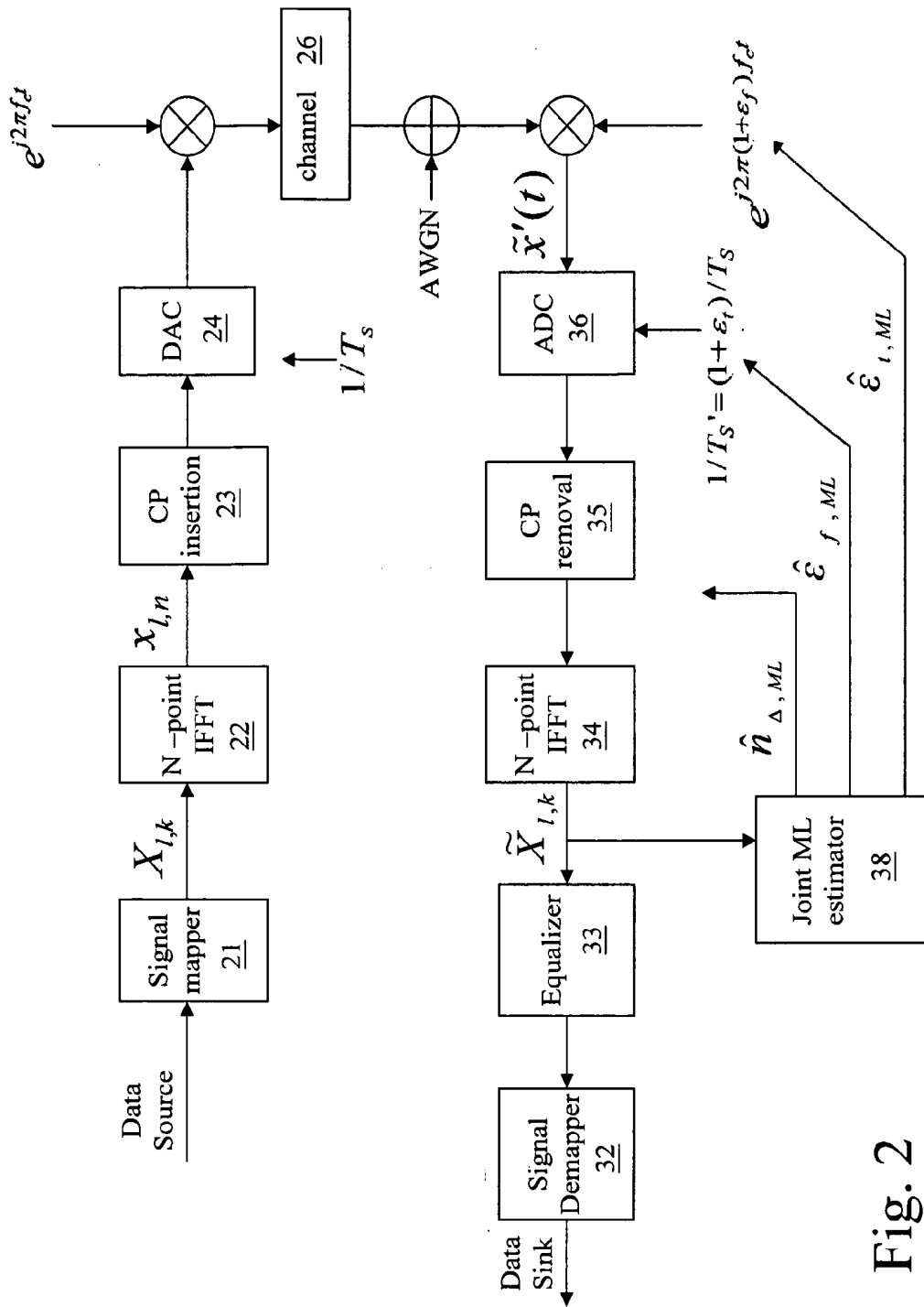

Fig. 2

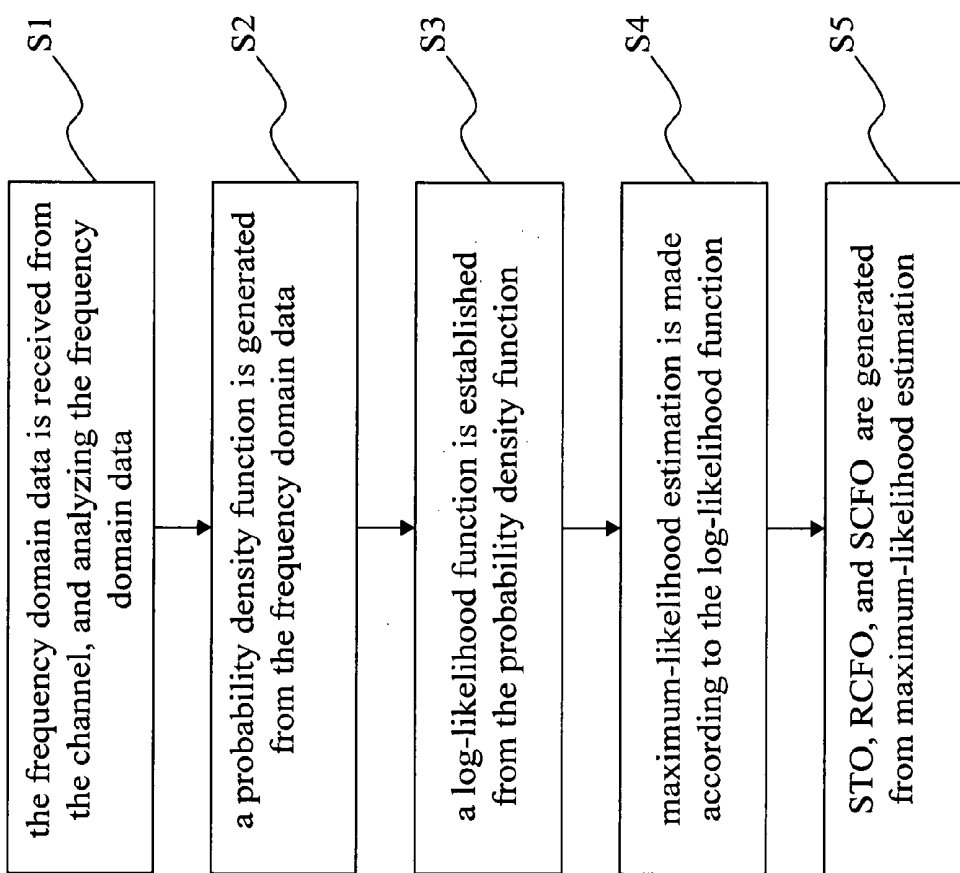

Fig. 3

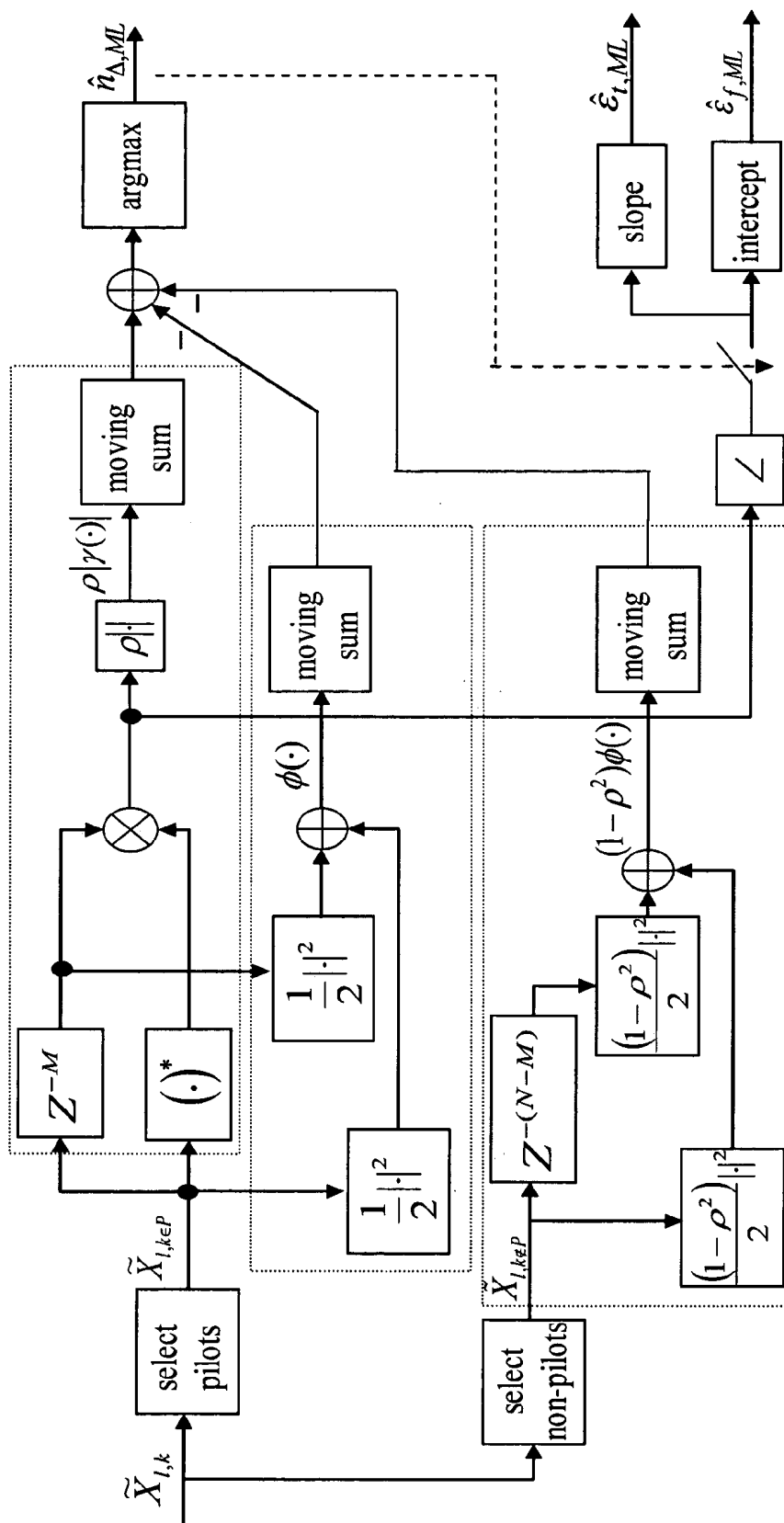

Fig. 4

SYMBOL TIME SYNCHRONIZATION METHOD FOR OFDM SYSTEMS

BACKGROUND OF THE INVENTION

[0001] 1. Field of the Invention

[0002] The present invention relates to a synchronization method for communication systems, and more especially, to a symbol time synchronization method for OFDM systems.

[0003] 2. Background of the Related Art

[0004] Orthogonal frequency division multiplexing (OFDM) is a promising technology for broadband transmission due to its high spectrum efficiency, and its robustness to the effects of multipath fading channels. However, it is sensitive to synchronization errors. As a result, one has to achieve as good synchronization as possible in OFDM transmissions.

[0005] Like other communication systems, there are many synchronization issues should be taken into considerations in OFDM systems. First of all, unknown signal delays will introduce symbol time offset (STO) and require coarse symbol time (CST) and fine symbol time (FST) synchronizations. There also exists carrier frequency offset between a transmitter and a receiver so that fractional carrier frequency offset (FCFO), integral carrier frequency offset (ICFO) and residual carrier frequency offset (RCFO) have to be eliminated. In addition, the sampling clocks mismatch between DAC and ADC will introduce sampling clock frequency offset (SCFO).

[0006] In J. J. van de Beek, M. Sandell and P. O. Borjesson's "ML estimation of time and frequency offset in OFDM systems," (IEEE Trans. Signal Process., vol. 45, no. 7, pp. 1800-1805, July 1997), STO and FCFO are jointly estimated by a delayed-correlation algorithm. It is an ML estimation and only good for AWGN channels.

[0007] In T. M. Schmidl and D. C. Cox's "Robust frequency and timing synchronization for OFDM," (IEEE Trans. Commun., vol. 45, no. 12, pp. 1613-1621, December 1997), a new method making use of training symbols in time-domain was proposed. However, its correlation results exhibit uncertain plateau in multipath fading channels.

[0008] Some techniques, for example in H. Minn, V. K. Bhargava and K. B. Letaief's "A robust timing and frequency synchronization for OFDM systems," (IEEE Trans. Wireless Commun., vol. 2, no. 4, pp. 822-839, July 2003), produce good ST (symbol time) performances. However, extra time-domain training symbols are needed.

[0009] The techniques mentioned above are applied to AWGN and/or static multiple channel condition, thus will not be suitable for real environments.

[0010] Although the technique in K. Ramasubramanian and K. Baum's "An OFDM timing recovery scheme with inherent delay-spread estimation," (GLOBECOM'01. IEEE. vol. 5, pp. 3111-3115, Nov. 2001.7) can identify ISI-free region in multipath fading channels, for accurate ST estimation, it may involve too many symbols.

[0011] In M. Speth, S. Fechtel, G. Fock and H. Meyer's "Optimum receiver design for OFDM-based broadband transmission-part II: a case study," (IEEE Trans. Commun., vol. 49, no. 4, pp. 571-578, Apr. 2001.8), for FST, channel responses must be estimated first, IFFT is then applied to get the channel impulse responses (CIR) and adjust the symbol boundary. Hence, its computational complexity is high.

[0012] The work in D. Lee and K. Cheun's "Coarse symbol synchronization algorithms for OFDM systems in multipath channels," (IEEE Commun. Letter, vol. 6, no. 10, pp. 446-448, October 2002.), treats CST in multipath fading channels.

[0013] T. Lv, H. Li and J. Chen's "Joint estimation of symbol timing and carrier frequency offset of OFDM signals over fast time-varying multipath channels," (IEEE Trans. Signal Process., vol. 53, no. 12, pp. 4526-4535, December 2005.) and J. C. Lin, "Maximum-likelihood frame timing instant and frequency offset estimation for OFDM communication over a fast Rayleigh-fading channel," (IEEE Trans. Vehicular Tech., vol. 52, no. 4, pp. 1049-1062, July 2003.) assume that normalized Doppler frequency (NDF) is known. This restricts their applicability.

SUMMARY OF THE INVENTION

[0014] In order to solve the problems mentioned above, the present invention provides a symbol time synchronization method for OFDM systems. The present invention provides a joint maximum-likelihood (ML) synchronization method for symbol time offset (STO), wherein the method is developed in frequency-domain under time-variant multipath channels. By analyzing the received frequency-domain data, a mathematical model for the joint effects of STO, CFO and SCFO is derived, thus the present invention is suitable for high mobility and non-line-of-sight (NLOS) applications

[0015] To achieve the purpose mentioned above, the present invention provides a symbol time synchronization method for OFDM systems, which includes: receiving frequency domain data from a plurality of channels, and analyzing the frequency domain data; generating a probability density function from the frequency domain data; establishing a log-likelihood function from the probability density function; making maximum-likelihood estimation according to the log-likelihood function; and generating symbol time offset (STO) from the maximum-likelihood estimation.

BRIEF DESCRIPTION OF THE DRAWINGS

[0016] The foregoing aspects and many of the accompanying advantages of this invention will become more readily appreciated as the same becomes better understood by reference to the following detailed description, when taken in conjunction with the accompanying drawings, wherein:

[0017] FIG. 1 illustrating three consecutive symbols' ST in an OFDM system;

[0018] FIG. 2 illustrating an OFDM system according to one embodiment of the present invention;

[0019] FIG. 3 illustrating a symbol time synchronization method for OFDM systems according to one embodiment of the present invention; and

[0020] FIG. 4 illustrating architecture of the joint ML estimator according to one embodiment of the present invention.

DETAILED DESCRIPTION OF THE INVENTION

[0021] Symbol time (ST) estimation is usually the first step in an entire OFDM synchronization process, because it provides an estimated OFDM symbol boundary for the remaining synchronization steps. As shown in FIG. 1 is three consecutive symbols' ST in an OFDM system, three consecutive symbols are (l-1)th Symbol, (l)th Symbol and (l+1)th Symbol. Everyone has a guard interval (GI), and an estimated ST generally falls into one of the three defined regions, where Bad ST1 and Good ST3 are in the guard interval (of length N_g) of an OFDM symbol. In the figure, Bad ST1 region and Bad ST2 region for the lth symbol has inter-symbol interference (ISI) from the (l-1)th symbol and the (l+1)th symbol, respectively. On the other hand, in time-invariant channels, if

ST is located in Good ST3 region, there will be no ISI but only phase rotation in the demodulated frequency-domain data, which can be simply compensated by single-tap equalizers.

[0022] The FIG. 2 shows an OFDM system according to one embodiment of the present invention. In the transmitter side, the baseband digital signals go through signal mapper **21** and processed by N-point IFFT **22**, the Inverse Fast Fourier Transform, then inserted the CP (cyclic prefix) in the guard interval **23**, performed D/A conversion in DAC **24**, and finally deliver them to the channel **26**.

[0023] In the receiver side, the radio waves are received from the channel **26**, they are demodulated, and sampled in the ADC **36** to convert to digital signals. The CP in the digital signals are removed in CP removal **35**, then processed by N-point FFT **34**, equalizer **33**, and signal demapper **32**, finally the receiver derives serial digital signals.

[0024] In addition, the joint ML estimator **38** is coupled to the output of N-point FFT **34**, the symbol time offset (STO) calculated by the estimator, and the STO is then feedback to the CP removal **35** for symbol time synchronization.

[0025] In the FIG. 2, $X_{l,k}$ is the transmitted/received frequency-domain data on the kth subcarrier, $x_{l,m}$ is the transmitted time-domain data sample of the lth symbol, $\tilde{x}^l(t)$ is the received continuous-time signal, N is FFT size, and $N_S = N + N_G$ is an OFDM symbol length including cyclic prefix (CP); $1/T_S$ is the transmitter sampling frequency, and $1/T_S' = (1 + \epsilon_f)/T_S$ is the receiver sampling frequency, where ϵ_f is the SCFO normalized by $1/T_S$, ϵ_f is the CFO normalized by subcarrier spacing; f_c is the carrier frequency, $\hat{n}_{\Delta,ML}$ is the estimated ML STO, $\hat{\epsilon}_{f,ML}$ is the estimated ML RCFO and $\hat{\epsilon}_{t,ML}$ is the estimated ML SCFO.

[0026] The FIG. 3 shows a symbol time synchronization method for OFDM systems according to one embodiment of the present invention. The method includes: step S1 the frequency domain data is received from the channel, and analyzing the frequency domain data; step S2 a probability density function is generated from the frequency domain data; step S3 a log-likelihood function is established from the probability density function; step S4 maximum-likelihood estimation is made according to the log-likelihood function; and step S5 symbol time offset (STO), residual carrier frequency offset (RCFO), and sampling clock frequency offset (SCFO) are generated from maximum-likelihood estimation.

[0027] Here, $h_l(n, \tau)$ is the baseband time-variant channel impulse response of the lth symbol. It is assumed wide-sense stationary and uncorrelated scattering (WSSUS), and can be modeled as a tapped-delay-line channel. A scattering function can be modeled as a time-varying function of Doppler frequency. The present invention assumes that the delay power spectrum follows an exponential distribution of the Doppler spectrum. Based on these assumptions, the cross-correlation of a CIR is given by

Equation (1)

$$E[h_l(n_1, \tau_1)h_l^*(n_2, \tau_2)] = E[h_l(n_1, \tau_1)h_l^*(n_2, \tau_2)] \times \delta(\tau_1 - \tau_2) \quad (1)$$

$$= \gamma \cdot J_0(\beta \cdot \Delta n) \cdot e^{-T|\tau_d|} \Big|_{\tau_1=\tau_2}$$

where γ is a normalization constant, $J_0(\cdot)$ is the zeroth-order Bessel function of the first kind, $\beta = 2\pi f_d T/N$, $\Delta n = (n_1 - n_2)$, f_d represents the maximum Doppler shift in Hertz, $T = NT_s$ is the

symbol duration and τ_d is the maximum delay spread. NDF is interchangeable with $f_d T$ here.

[0028] The estimated ST will be located in one of three different regions as depicted in FIG. 1, where STO is with reference to the ideal ST of the lth symbol which is marked by the time index at zero. Detailed analysis of the received frequency-domain data in these three regions is omitted and the result is shown below.

Case 1: In Good ST3 region.

[0029] Step A1:

$$\tilde{X}_{l,k} \approx \hat{H}_{1,k} X_{l,k} W_N^{[N_S(k\epsilon_f - \epsilon_f) - kn\Delta]} \hat{N}_{1,k}$$

[0030] where

$$W_n \triangleq e^{-j2\pi n/N}$$

and σ_k is AWGN;

[0031] Step A2:

$$\hat{H}_{1,k} \triangleq \frac{1}{N} \sum_{n'=0}^{N-1} H_l(n', k) \times W_N^{-n'(\epsilon_f - k\epsilon_f)}$$
, and

[0032] Step A3:

$$\hat{N}_{1,k} \triangleq \sum_{m \neq k} X_{l,m} \left[\frac{1}{N} \sum_{n'=0}^{N-1} H_l(n', m) \times W_N^{-n'[m(1-\epsilon_f) - k + \epsilon_f]} \right] \times W_N^{[N_S(m\epsilon_f - \epsilon_f)]} \times W_N^{-kn\Delta} + v_k$$

Case 2: In Bad ST1 region.

[0033] Step A4:

$$\tilde{X}_{l,k} \approx \hat{H}_{2,k} X_{l,k} W_N^{[N_S(k\epsilon_f - \epsilon_f) - kn\Delta]} \hat{N}_{2,k}$$

[0034] where

$$\hat{H}_{2,k} \triangleq \frac{1}{N} \sum_{n'=N_1}^{N_1} H_l(n', k) \times W_N^{-n'(\epsilon_f - k\epsilon_f)}$$

$$N_1 = -N_G + \tau_d - n_{\Delta} + 1,$$

$$\hat{N}_{2,k} \triangleq \hat{N}_{1,k} - \hat{X}_{l,k}^{ici,1} + \hat{X}_{l,k}^{isi,1}$$

[0035] Step A5:

$$\tilde{X}_{l,k}^{ici,1} \approx \sum_{m \neq k} X_{l,m} \left[\frac{1}{N} \sum_{n'=0}^{N_1-1} H_l(n', m) \times W_N^{-n'[m(1-\epsilon_f) - k + \epsilon_f]} \right] \times$$

$$W_N^{[N_S(m\epsilon_f - \epsilon_f)]} \times W_N^{-kn\Delta}, ; \text{ and}$$

[0036] Step A6:

$$\tilde{X}_{l,k}^{isi,1} \approx \sum_{m=-K} X_{l-1,m} \left[\frac{1}{N} \sum_{n'=0}^{N_1-1} H_{l-1}(n' + N_G, m) \times W_N^{-n'[m(1-\epsilon_f) - k + \epsilon_f]} \right] \times W_N^{IN_S(m\epsilon_f - \epsilon_f)} \times W_N^{-k(n_\Delta - N_G)}.$$

Case 3: In Bad ST2 region.

[0037] Step A7:

$$\tilde{X}_{l,k} \approx \hat{H}_{3,k} X_{l,k} W_N^{IN_S(k\epsilon_f - \epsilon_f) - kn_\Delta} + \hat{N}_{3,k},$$

[0038] where

$$\hat{H}_{3,k} \triangleq \frac{1}{N} \sum_{n'=0}^{N-N_\Delta-1} H_l(n', k) \times W_N^{-n'(e_f - k\epsilon_f)},$$

$$\hat{N}_{3,k} \triangleq \hat{N}_{1,k} - \tilde{X}_{l,k}^{ici,2} + \tilde{X}_{l,k}^{isi,2};$$

[0039] Step A8:

$$\tilde{X}_{l,k}^{ici,2} \approx \sum_{m=k} X_{l,m} \left[\frac{1}{N} \sum_{n'=N-N_\Delta}^{N_1-1} H_l(n', m) \times W_N^{-n'[m(1-\epsilon_f) - k + \epsilon_f]} \right] \times W_N^{IN_S(m\epsilon_f - \epsilon_f)} \times W_N^{-kn_\Delta}; \text{ and}$$

[0040] Step A9:

$$\tilde{X}_{l,k}^{isi,2} \approx \sum_{m=-K} X_{l+1,m} \left[\frac{1}{N} \sum_{n'=N-N_\Delta}^{N_1-1} H_{l+1}((n' - N_G)_N, m) \times W_N^{-n'[m(1-\epsilon_f) - k + \epsilon_f]} \right] \times W_N^{IN_S(m\epsilon_f - \epsilon_f)} \times W_N^{-k(n_\Delta - N_G)}.$$

[0041] (From A1~A9, there are approximations “ \approx ” because detailed derivations are omitted.) From Step (A1), (A4) and (A9), the present invention illustrates that the received data is multiplied by different time-averaged time-variant transfer functions. The interferences are also different in different regions. They can be well approximated by Gaussian random variables. As such, the received frequency-domain data can be rewritten as Equation (2).

$$\tilde{X}_{l,k} \approx \hat{H}_{i,k} X_{l,k} W_N^{IN_S(k\epsilon_f - \epsilon_f) - kn_\Delta} + \hat{N}_{i,k}, \quad i=1, 2, 3. \quad (2)$$

Note that index i that denotes the three different regions will be dropped for clarity.

[0042] It is assumed that $X_{l,k}$ is an evenly-spaced pseudo random binary sequence (PRBS) for $k \in P$, P is the pilot set. $X_{l,k}$'s are assumed uncorrelated and zero mean for $k \notin P$. Therefore Equation (3) exists,

$$E[X_{l_1, k_1} X_{l_2, k_2}^*] = \begin{cases} \sigma_X^2 \delta(k_1 - k_2), & k_1, k_2 \in p \\ \sigma_X^2 \delta(l_1 - l_2) \delta(k_1 - k_2), & \text{otherwise} \end{cases} \quad (3)$$

where σ_x^2 is the signal power and $\delta(\cdot)$ is Dirac delta function. By Equation (2) and Equation (3), the correlation between two consecutive frequency-domain symbols can be written as Equation (4).

$$E[\tilde{X}_{l_1, k_1} \tilde{X}_{l_2, k_2}^*] = \begin{cases} \sigma_{\hat{H}_k}^2 \sigma_X^2 + \sigma_{\hat{N}_k}^2, & l_1 = l_2 \\ & k_1 = k_2 = k \\ \sigma_{\hat{H}_k}^2 \sigma_X^2 W_N^{-N_S(k\epsilon_f - \epsilon_f)}, & l_2 = l_1 + 1 \\ & k_1 = k_2 = k, k \in P \\ 0, & \text{otherwise} \end{cases}, \quad (4)$$

[0043] From Equation (4), $f(\tilde{X}_{l,k})$, $f(\tilde{X}_{l+1,k})$, $f(\tilde{X}_{l,k})$ and $f(\tilde{X}_{l+1,k})$ in Equation (5) is described by Equation (4.1) and (4.2)

$$f(\tilde{X}_{l,k}, \tilde{X}_{l+1,k}) = \quad (4.1)$$

$$\exp\left(-\frac{|\tilde{X}_{l,k}|^2 - 2\rho_k \operatorname{Re}\left[W_N^{-N_S(k\epsilon_f - \epsilon_f)} \cdot \tilde{X}_{l,k} \tilde{X}_{l+1,k}^*\right] + |\tilde{X}_{l+1,k}|^2}{2(\sigma_{\hat{H}_k}^2 \sigma_X^2 + \sigma_{\hat{N}_k}^2)(1 - \rho_k^2)}\right) \frac{1}{2\pi(\sigma_{\hat{H}_k}^2 \sigma_X^2 + \sigma_{\hat{N}_k}^2)(1 - \rho_k^2)^{1/2}},$$

$$f(\tilde{X}_{l,k}) = \frac{\exp\left(-\frac{|\tilde{X}_{l,k}|^2}{2(\sigma_{\hat{H}_k}^2 \sigma_X^2 + \sigma_{\hat{N}_k}^2)}\right)}{\left[2\pi(\sigma_{\hat{H}_k}^2 \sigma_X^2 + \sigma_{\hat{N}_k}^2)\right]^{1/2}}. \quad (4.2)$$

Note that $\tilde{X}_{l+1,k}$ has the same pdf with $\tilde{X}_{l,k}$.

[0044] The corresponding log-likelihood function of Equation (4) can be written as Equation (5).

$$\Lambda(n_\Delta, \epsilon_f, \epsilon_r) = \log\left(\prod_{k \in P} f(\tilde{X}_{l,k}, \tilde{X}_{l+1,k}) \times \prod_{k \notin P} f(\tilde{X}_{l,k}) f(\tilde{X}_{l+1,k})\right) \quad (5)$$

where $f(\cdot)$ denotes the probability density function (and the conditioning on $(n_\Delta, \epsilon_f, \epsilon_r)$ are dropped for notational clarity). Therefore, Equation (5) can be derived in Equation (5.1).

$$\Lambda(n_\Delta, \epsilon_f, \epsilon_r) = \quad (5.1)$$

$$\sum_{k \in P} \left\{ c_{2,k} |\gamma(n_\Delta)| \cos\left[\frac{2\pi N_S(k\epsilon_f - \epsilon_f)}{N} - L\gamma(n_\Delta)\right] - c_{3,k} \Phi(n_\Delta) \right\} - \sum_k c_{4,k} \Phi(n_\Delta) + c_1$$

where

$$c_1 = -\left[\sum_{k \in P} \log(1 - \rho_k^2)\right] / 2 - \sum_k \log 2\pi(\sigma_{\hat{H}_k}^2 \sigma_X^2 + \sigma_{\hat{N}_k}^2)$$

$$c_{2,k} = \rho_k / (\sigma_{\hat{H}_k}^2 \sigma_X^2 + \sigma_{\hat{N}_k}^2)(1 - \rho_k^2)$$

$$c_{3,k} = \rho_k c_{2,k}; \quad c_{4,k} = c_{2,k}(1 - \rho_k^2) / \rho_k.$$

ρ_k is the magnitude of the correlation coefficient between $\tilde{X}_{t,k}$ and $\tilde{X}_{t+1,k}$ as shown in Equation (6).

$$\rho_k \triangleq \left| \frac{E[\tilde{X}_{t,k} \tilde{X}_{t+1,k}^*]}{\sqrt{E[|\tilde{X}_{t,k}|^2] E[|\tilde{X}_{t+1,k}|^2]}} \right|, k \in P. \quad (6)$$

[0045] In addition with Equations (7) and (8),

$$\gamma(n_\Delta) \triangleq \tilde{X}_{t,k} \tilde{X}_{t+1,k}^*, \quad (7)$$

$$\Phi(n_\Delta) \triangleq \frac{1}{2} (|\tilde{X}_{t,k}|^2 + |\tilde{X}_{t+1,k}|^2) \quad (8)$$

the maximization of the log-likelihood function can be performed in two steps as shown in Equation (9),

$$\begin{aligned} \max_{(n_\Delta, \varepsilon_f, \varepsilon_r)} \Lambda(n_\Delta, \varepsilon_f, \varepsilon_r) &= \max_{n_\Delta} \max_{(\varepsilon_f, \varepsilon_r)} \Lambda(n_\Delta, \varepsilon_f, \varepsilon_r) \\ &= \max_{n_\Delta} \Lambda(n_\Delta, \varepsilon_{f,ML}, \varepsilon_{r,ML}). \end{aligned} \quad (9)$$

[0046] Obviously, under the condition of optimal RCFO and SCFO, i.e.,

$$(\varepsilon_f, \varepsilon_r) \triangleq (\varepsilon_{f,ML}, \varepsilon_{r,ML}),$$

Equation (5) is reduced to Equation (10).

$$\Lambda(n_\Delta, \varepsilon_{f,ML}, \varepsilon_{r,ML}) = \sum_{k \in P} (c_{2,k} |\gamma(n_\Delta)| - c_{3,k} \Phi(n_\Delta)) - \sum_k c_{4,k} \Phi(n_\Delta). \quad (10)$$

[0047] Hence, the optimal ST $n_\Delta \triangleq n_{\Delta,ML}$ can be obtained by maximizing Equation (5), and the joint ML estimation includes following steps:

[0048] Step 1: Estimate by using Equation (11).

$$\hat{n}_{\Delta \dots ML} = \arg \max_{n_\Delta} \left[\sum_{k \in P} (c_{2,k} |\gamma(n_\Delta)| - c_{3,k} \Phi(n_\Delta)) - \sum_k c_{4,k} \Phi(n_\Delta) \right], \quad (11)$$

[0049] Step 2: Given $\hat{n}_{\Delta,ML}$, estimate $(\hat{\varepsilon}_{f,ML}, \hat{\varepsilon}_{r,ML})$ by using the constraint in Equation (12).

$$k \hat{\varepsilon}_{t,ML} - \hat{\varepsilon}_{f,ML} = \frac{1}{2\pi} \frac{N}{N_s} L \gamma(\hat{n}_{\Delta,ML}). \quad (12)$$

[0050] Note the present invention assumes that the condition $|\ln_s(k\varepsilon_f - \varepsilon_r)| < 1/2$ is satisfied so that there is no phase ambiguity. The joint SCFO and RCFO can be estimated by Equation (13).

$$\begin{cases} \hat{\varepsilon}_{t,ML} = \frac{1}{2\pi} \frac{N}{N_s} \frac{1}{M} L \left(\sum_{k \in P^+} \tilde{X}_{t,k} \tilde{X}_{t+1,k}^* - \sum_{k \in P^-} \tilde{X}_{t,k} \tilde{X}_{t+1,k}^* \right) \\ \hat{\varepsilon}_{f,ML} = -\frac{1}{2\pi} \frac{N}{N_s} L \left(\sum_{k \in P^+} \tilde{X}_{t,k} \tilde{X}_{t+1,k}^* + \sum_{k \in P^-} \tilde{X}_{t,k} \tilde{X}_{t+1,k}^* \right) \end{cases} \quad (13)$$

where P^+ , $P^- \in P$ are the set of positive/negative frequency-domain pilots.

[0051] In the present invention, each ensemble average value of ρ_k must be found. However, it is impractical to estimate it by using its time average value. A practical solution to this problem is that we can reasonably assume a single averaged value ρ for all ρ_k 's as shown in Equation (14).

$$\rho = \frac{\sum_k |\tilde{X}_{t,k} \tilde{X}_{t+1,k}^*|}{\sqrt{\sum_k |\tilde{X}_{t,k}|^2 \sum_k |\tilde{X}_{t+1,k}|^2}}. \quad (14)$$

[0052] That is, the denominator and numerator of ρ_k are replaced by the averaged values of

$$\sqrt{\frac{\sum_k |\tilde{X}_{t,k}|^2 \sum_k |\tilde{X}_{t+1,k}|^2}{N}} \text{ and } \frac{\sum_k |\tilde{X}_{t,k} \tilde{X}_{t+1,k}^*|}{N},$$

respectively. Hence, the ML estimation (11) can be simplified as Equation (15).

$$\hat{n}_{\Delta,ML} = \arg \max_{n_\Delta} \left[\sum_{k \in P} (\rho |\gamma(n_\Delta)| - \Phi(n_\Delta)) - \sum_{k \notin P} (1 - \rho^2) \Phi(n_\Delta) \right]. \quad (15)$$

[0053] The ML estimations of SCFO and RCFO under the simplified condition are still the same as (13). A realization of (15) and (13) is shown in FIG. 4.

[0054] By approximating interferences as Gaussian distributed random processes, a joint ML method for the three major synchronization errors is presented. The method is robust in the sense that the estimation's MSE is low and does not degrade significantly under low SNR and high mobility conditions in time-variant multipath fading channels. As such, the proposed technique is suitable for high mobility and non-line-of-sight (NLOS) applications, like 802.16e. In addition, the method is efficient in the sense that STO, RCFO and SCFO are jointly estimated at the same time.

[0055] Accordingly, the feature of the present invention is to provide a joint maximum-likelihood (ML) synchronization method for symbol time offset (STO), carrier frequency offset (CFO) and sampling clock frequency offset (SCFO) for OFDM systems. Unlike most existing techniques which are time-domain approaches considering only AWGN and/or static multipath conditions, the proposed algorithm is developed in frequency-domain under time-variant multipath channels. By analyzing the received frequency-domain data, a mathematical model for the joint effects of STO, CFO and SCFO is derived. The results are used to formulate a log-likelihood function of two consecutive symbols. Based on the function, a joint ML algorithm is proposed. The method is

both efficient and robust, because the three main synchronization issues are treated altogether. Simulation results exhibit high performances in time-variant multipath fading channels. **[0056]** Although the present invention has been explained in relation to its preferred embodiment, it is to be understood that other modifications and variation can be made without departing the spirit and scope of the invention as hereafter claimed.

What is claimed is:

1. A symbol time synchronization method for OFDM systems, the method comprising:

- receiving frequency domain data from a plurality of channels, and analyzing said frequency domain data;
- generating a probability density function from said frequency domain data;
- establishing a log-likelihood function from said probability density function;
- doing maximum-likelihood estimation according to said log-likelihood function; and
- generating symbol time offset (STO) from said maximum-likelihood estimation.

2. The symbol time synchronization method for OFDM systems according to claim 1, wherein said frequency domain data are

$$\tilde{X}_{i,k} = \hat{H}_{i,k} X_{i,k} W_N^{jN_s(k\epsilon_t - k\Delta)} + \hat{N}_{i,k}, \quad i=1, 2, 3.$$

3. The symbol time synchronization method for OFDM systems according to claim 1, wherein said frequency domain data is analyzed by

$$E[\tilde{X}_{l_1, k_1} \tilde{X}_{l_2, k_2}^*] = \begin{cases} \sigma_{\hat{H}_k}^2 \sigma_X^2 + \sigma_{\hat{N}_k}^2, & l_1 = l_2 \\ & k_1 = k_2 = k \\ \sigma_{\hat{H}_k}^2 \sigma_X^2 W_N^{-N_s(k\epsilon_t - \epsilon_f)}, & l_2 = l_1 + 1 \\ & k_1 = k_2 = k, k \in P \\ 0, & \text{otherwise} \end{cases}$$

4. The symbol time synchronization method for OFDM systems according to claim 1, wherein said log-likelihood function is

$$\Lambda(n_\Delta, \epsilon_f, \epsilon_t) = \log \left(\prod_{k \in P} f(\tilde{X}_{l,k}, \tilde{X}_{l+1,k}) \times \prod_{k \notin P} f(\tilde{X}_{l,k}) f(\tilde{X}_{l+1,k}) \right).$$

5. The symbol time synchronization method for OFDM systems according to claim 1, wherein said log-likelihood function may be simply expressed in

$$\Lambda(n_\Delta, \epsilon_f, ML, \epsilon_t, ML) = \sum_{k \in P} (c_{2,k} |\gamma(n_\Delta)| - c_{3,k} \Phi(n_\Delta)) - \sum_k c_{4,k} \Phi(n_\Delta).$$

6. The symbol time synchronization method for OFDM systems according to claim 1, wherein said generating symbol time offset (STO) from

$$\hat{n}_{\Delta, ML} = \operatorname{argmax}_{n_\Delta} \left[\sum_{k \in P} (c_{2,k} |\gamma(n_\Delta)| - \Phi_{c_{3,k}}(n_\Delta)) - \sum_k c_{4,k} \Phi(n_\Delta) \right].$$

7. The symbol time synchronization method for OFDM systems according to claim 1, further comprising using a single averaged value ρ for all ρ_k , said single averaged value ρ may be

$$\rho = \frac{\sum_k |\tilde{X}_{l,k} \tilde{X}_{l+1,k}^*|}{\sqrt{\sum_k |\tilde{X}_{l,k}|^2 \sum_k |\tilde{X}_{l+1,k}|^2}}.$$

8. The symbol time synchronization method for OFDM systems according to claim 1, wherein said maximum-likelihood estimation is

$$\hat{n}_{\Delta, ML} = \operatorname{argmax}_{n_\Delta} \left[\sum_{k \in P} (\rho |\gamma(n_\Delta)| - \Phi(n_\Delta)) - \sum_{k \notin P} (1 - \rho^2) \Phi(n_\Delta) \right].$$

* * * * *