

ABSTRACT

Personal communications services (PCS) are being introduced to offer ubiquitous communication. In its first phase PCS consists of a plethora of systems that address cellular, vehicular, cordless phone, and a variety of other services. The integration of these different systems is referred to as "heterogeneous PCS (HPCS)." In this article we describe the various PCS systems available and address in detail the issue of PCS systems integration. Key implementation issues for integrating PCS systems are defined and discussed.

Heterogeneous Personal Communications Services: Integration of PCS Systems

Yi-Bing Lin, National Chaio Tung University

Imrich Chlamtac, Boston University

The name "personal communications services" (PCS) is often used as an umbrella term that includes various wireless access and personal mobility services with the ultimate goal of enabling communication, through a small terminal, with a person at any time, at any place, and in any form. The business opportunities are tremendous, since one can imagine that every person (not just every home) could be equipped as long as the service is inexpensive enough.

Under the PCS umbrella, several wireless communications systems have achieved rapid growth due to heavy market demand. Obvious examples include high-tier digital cellular systems like GSM (Global System for Mobile Communication), ADC (American Digital Cellular or IS-54), PDC (Personal Digital Cellular), and DCS1800 (Digital Communication System at 1800 MHz) for widespread vehicular and pedestrian services, and low-tier cordless telecommunication systems based on CT2 (Cordless Telephone 2), DECT (Digital European Cordless Telephone), PACS (personal access communications systems), and PHS (personal handy phone system) standards for residential, business, and public cordless access applications. Although the design guidelines of such systems are quite different, their individual successes may suggest a potential path to achieving a complete PCS vision: integration of different PCS systems, which is referred to as "heterogeneous PCS" (HPCS).

Several personal communications technologies have been proposed and intensively studied [1, 2]. Two of the most popular technologies are *cellular telephony* and *cordless telephony*. Both technologies have similar architectures, as shown in Fig. 1. The basic architecture consists of two parts.

The Radio Network — PCS users carry handsets or mobile stations (MSs) to communicate with the base station (BS) of the PCS network. For some systems, such as GSM [3, 4] and PACS, the BS is partitioned into a controller (*base station controller*, or BSC, in GSM and *radio port control unit* in PACS) and radio transmitter/receiver (*base transceiver station*, or BTS, in GSM and *radio port* in PACS). The BSs connect to the backbone network via wirelines or dedicated microwave links.

The Backbone Wireline Network — The mobile switching center (MSC), or an advanced intelligent network (AIN)

switch in PACS, connected to the BS is a special switch tailored for mobile applications. The MSC also connects to the public switched telephone network (PSTN) to provide services between PCS and wireline users. The MSC also communicates with location registration databases such as the home location register (HLR) and the visitor location register (VLR) to provide roaming management.

Although the cellular and the cordless systems have similar architectures, their design guidelines are different (to be elaborated in the next section).

Integration of different PCS systems has been proposed recently [5, 6], particularly integration of cellular and cordless systems to provide the advantages of the individual systems. Rizzo and Sollenberger [5] focused on different radio technology, different network technology (DRDN) integration (to be described in the next section), and the integrated system is referred to as a *multitier system*. Lee [6] focused on different radio technology, same network technology (DRSN) technology. This integrated system is referred to as *multiservices multi-systems broadband radio*. We generalize the concept of PCS system integration, and refer to the integrated system as heterogeneous PCS (HPCS).

This article describes several PCS systems and the types of PCS system integration. Then we discuss the implementation issues for integrating PCS systems.

PCS TECHNOLOGY

This section describes several popular cellular and cordless systems. We first introduce four cellular systems: AMPS, GSM, IS-54 (IS-136), and IS-95.

The first cellular system, Advanced Mobile Phone Service (AMPS), was developed during the 1970s by Bell Laboratories. This "first-generation" analog cellular system has been available since 1983. Frequency division multiple access (FDMA) technology is used in AMPS to achieve radio communications. With FDMA, voice channels are carried by different radio frequencies. A total 50 MHz in the bands 824–849 MHz and 869–894 MHz is allocated for AMPS. This spectrum is divided into 832 frequency channels or 416 downlinks (the transmission paths from the BSs to the handsets) and 416 uplinks (the transmission paths from the handsets to the BSs). The FDMA approach can be implemented with frequency

reuse. The cells (the coverage areas of base stations) are grouped into clusters. Cells within a cluster may interfere with each other, and thus must use different frequencies. A frequency may be reused by cells in different clusters. In AMPS, the typical frequency reuse plan employs either a 12-group frequency cluster with omnidirectional antennas or a 7-group cluster with three sectors per cell. Thus, there are about 50 channels per cell. Motorola uses 4 cells/6 sectors in its AMPS system. AMPS follows the Electronics/Telecommunications Industry Association (EIA/TIA) IS-41 [7-9] standard for roaming management (to be described).

GSM is a digital cellular system developed by Groupe Special Mobile of the European Conference of Posts and Telecommunications (CEPT) and its successor, the European Telecommunications Standard Institute (ETSI). GSM follows a technology that combines time division multiple access (TDMA) and FDMA, where a frequency carrier is divided into fixed time slots that are used for different voice channels. In GSM every frequency carrier supports up to eight voice channels. The speech coding rate is 13 kb/s. With TDMA, the radio hardware in the BS can be shared among multiple users. In a GSM BS every radio transceiver/receiver pair supports eight voice channels, while an AMPS BS needs a radio transceiver/receiver pair for every voice channel. The GSM roaming management protocol is similar to IS-41, and the details can be found in [3].

The EIA/TIA IS-54 digital cellular system (and the newer version, IS-136) [10] has been operational in the United States since 1987. This system uses TDMA and is also referred to as *digital AMPS* (DAMPS), *American digital cellular* (ADC), or *North American TDMA* (NA-TDMA). Using TDMA, every IS-54 frequency carrier supports three voice channels. The speech coding rate is 7.95 kb/s. The IS-54 systems must operate in the same spectrum used by the existing AMPS systems. The new version of IS-54 (IS-136) includes features such as point-to-point short messaging, broadcast messaging, group addressing, private user groups, hierarchical cell structures, and slotted paging channels to support a "sleep mode" in the handset (to conserve battery power). Like AMPS, the IS-41 standard is used for IS-54 mobility management.

EIA/TIA IS-95 [11] is a digital cellular system operating in the United States since 1989. IS-95 is based on code division multiple access (CDMA) technology. As explained in [11, pp. 337-38], the CDMA *direct sequence spread spectrum* technology works as follows: The information-bearing signal is mixed with another faster-rate, wider-bandwidth digital signal that carries a unique orthogonal code (this second signal is referred to as a *pseudo-noise sequence*). The mixed signal looks very similar to a noise signal, but contains the information signal embedded in its code. Thus, CDMA allows many users to share a common channel for transmission, and the user signals are distinguished by spreading them with different codes. This technology optimizes the utilization of the frequency bandwidth, and, in practice, the capacity of CDMA is three to six times larger than that of TDMA. The speech coding rate is 8 kb/s. Like AMPS, the IS-41 standard is used for IS-95 mobility management.

Among cordless systems exist the CT2, DECT, and PACS systems.

CT2 has been developed in Europe and has been available since 1989. CT2 is allocated 40 FDMA channels with a 32 kb/s speech coding rate. For a user, both the base-to-handset signals and the handset-to-base signals are transmitted in the same frequency. This duplexing mode is referred to as time division duplexing (TDD). In a public CT2 system, call delivery is not supported (incoming calls have been supported in an enhanced version of CT2, but its efficiency has not been justified).

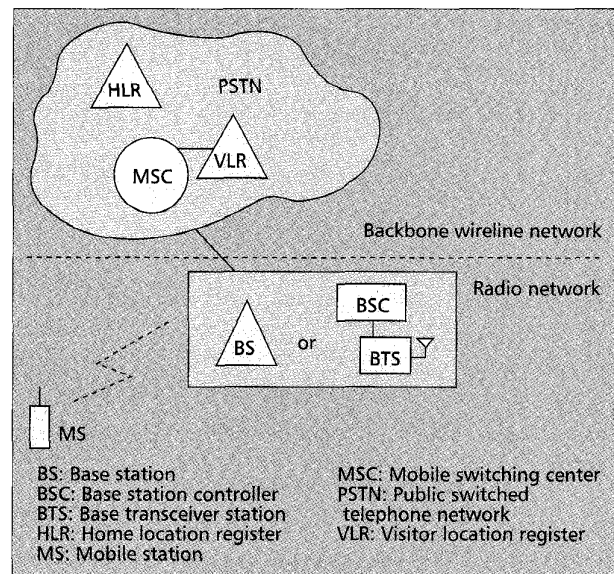

Figure 1. The basic PCS network architecture.

DECT specifications were published in 1992 for definitive adoption as the European cordless standard. DECT supports high user density with a picocell design. Using TDMA, there are 12 voice channels per frequency carrier. Like CT2, DECT follows a TDD duplexing mode and provides a 32 kb/s speech coding rate. This system is suitable for an uncoordinated environment where BSs need not be synchronized and the channels are dynamically allocated. DECT is typically connected to the PSTN through wireless private branch exchange (PBX). Roaming management such as IS-41 is not supported.

PACS is a low-power PCS system developed at Bellcore and is a standard in the United States. PACS was designed for wireless local loop use as well as for personal communications services. TDMA is used in PACS with eight voice channels per frequency carrier. Like CT2 and DECT, the speech coding rate is 32 kb/s. Unlike CT2 or DECT, frequency division duplexing (FDD) is used. That is, the PACS uplink and downlink utilize different frequency carriers, similar to cellular systems. PACS roaming management is supported by an IS-41-like protocol.

The above descriptions of cellular and cordless systems indicate that their design guidelines are different. The two technologies are typically distinguished by the characteristics listed in Table 1 [1, 2].

According to the table, a simplified conclusion is that cellular technology supports large coverage and high-speed users while cordless technology supports zonal coverage and low-speed users.

TYPES OF PCS SYSTEM INTEGRATION

Integration of different PCS systems has been proposed recently [5] particularly the integration of cellular and cordless systems to provide the advantages of the individual systems. We refer to the integrated PCS system as HPCS.

In HPCS, if the service areas of the individual PCS systems do not overlap, the major advantage of integrating these systems is to extend the coverage of the service area. If the service areas of the individual PCS systems do overlap, the systems typically operate at different frequency bands, and the major advantage of integration is to increase the capacity (i.e., to increase the number of communication circuits at the same area). Furthermore, depending on the technologies (i.e., cellular or cordless) of the individual systems, other benefits may

System	Cellular (High tier)	Cordless (Low tier)
Cell size	Large (0.5–35 km)	Small (50–500 m)
User speed	High (up to 250 km/hr)	Low (less than 50 km/hr)
Coverage area	Large and continuous	Small and zonal
Handset complexity	High	Low
Handset power consumption	High	Low
Speech coding rate	Low (8–13 kb/s)	High (32 kb/s)
Channel assignment	Inflexible* (fixed channel assignment)	Flexible (possibly dynamic channel allocation)
* This item does not apply to the CDMA technology.		

■ **Table 1.** Characteristics of cellular and cordless technologies.

be offered by HPCS. For example, by integrating a cellular system and a cordless system, the quality of circuits is improved (from the viewpoint of the cellular system) and higher user mobility is supported (from the viewpoint of the cordless system).

Table 2 lists the possible combinations of cellular and cordless technologies.

A basic requirement of HPCS is *downward compatibility*; that is, after integration, HPCS users will receive services from multiple PCS systems. At the same time, the original users of the individual PCS systems will still receive services from their systems without being affected by HPCS. Depending on the network and radio technologies, three types of integration are being considered.

SIMILAR RADIO TECHNOLOGY, SAME NETWORK TECHNOLOGY (SRSN)

In SRSN integration, the individual systems use the same network management (for roaming and call control) technology and the same radio technology, except the radio systems operate at either different power levels or different frequency bands.

SRSN with Different Power Levels — In a microcell/macrocell PCS architecture [2], the cell sizes of a cellular system are large (Table 1), and the cells are typically referred to as *macrocells*. Using the same air interface and network management procedures as for the macrocell system, the concept of *microcells* introduces low-complexity BSs that have low power consumption and small coverage areas (in some sense, the microcell technology evolves along the direction of cordless telephony). Microcell layout improves frequency reuse, and the microcells typically overlap with macrocells to increase the capacity of HPCS. The microcells must “borrow” some radio channels from the (nonoverlapping) neighboring macrocells, and slightly reduce the performance of these cells.

Microcells have been installed in some areas of Taiwan since 1995. The measurement data for a microcell installed in a commercial district of Taipei indicated that a single microcell is able to reduce the blocking probability from 10 percent to 0.8 percent, and increase profits by U.S. \$500,000/year per microcell.

SRSN with Different Frequency Bands — The same radio technology may be implemented in different frequency bands. Examples are GSM (at 900 MHz) and DCS-1800 (at 2 GHz). Since

these systems use different frequency bands, the overlapping areas do not cause interference problems. Thus, HPCS such as GSM/DCS-1800 may effectively increase the capacity of PCS.

DIFFERENT RADIO TECHNOLOGY, SAME NETWORK TECHNOLOGY (DRSN)

Examples of DRSN are IS-54/AMPS [10] and IS-95/AMPS [11]. The radio systems of IS-54 (based on TDMA technology) or IS-95 (based on CDMA technology) are different from those of AMPS (based on FDMA technology). All three PCS systems share the same network protocol: IS-41 [7–9]. The original purpose of the IS-54/AMPS and IS-95/AMPS integration is to serve as a graceful approach to gradually replacing the old technology (AMPS) with the new ones (IS-54 or IS-95). The IS-54 technology (which is compatible with AMPS) is operational in a majority of the top ten cellular markets in the United States [1]. IS-95 systems have been deployed in the Los Angeles, California, area.

DIFFERENT RADIO TECHNOLOGY, DIFFERENT NETWORK TECHNOLOGY (DRDN)

DRDN typically integrates cellular systems (high-tier) with cordless systems (low-tier) in the hope of maintaining the advantages of each. In DRDN, the low tier has priority for call delivery over the high tier because the low tier has the advantages of lower call delivery cost and better circuit quality compared to the high tier (Table 1). Examples of DRDN include AMPS-PACS, GSM-PACS (developed in Bellcore), and GSM-DECT in Europe.

TIER HANDOVER

The type of integration has a significant effect on the implementation of HPCS. One of the issues is *tier handover*, or handover between different systems. In a PCS system, when a handset moves from one cell to another during a conversation, the radio link between the handset and the new cell must be established, and the radio link between the handset and the old cell must be removed. The FDMA and TDMA PCS systems employ a *hard handover* approach where a handset talks to only one BS at a time. There are three types of hard handover.

In mobile-controlled handover (MCHO), the handset continuously monitors the signal strength and quality from the accessed BS and several handover candidate BSs. When the predefined handover criteria are met, the handset checks the best candidate BS for an available traffic channel and issues a handover request. In network-controlled handover (NCHO),

Technology	Advantages	Examples
Cellular-cellular (overlapping)	Increasing capacity	DCS1800/GSM
Cellular-cordless Cordless-cordless (overlapping)	Increasing capacity Improving circuit quality Increasing the user mobility	DECT/GSM PACS/AMPS Unlicensed PHS/licensed PACS
Cellular-cellular Cellular-cordless Cordless-cordless (non-overlapping)	Extending coverage	All examples listed above IS-54/AMPS, IS-95/AMPS IS-95/AMPS, and Unlicensed PHS/licensed PACS

■ **Table 2.** Integration of cellular and cordless technologies.

the BS monitors the signal strength and quality from the handset; when these deteriorate below some threshold, the network arranges for a handover to another BS. The network asks all the surrounding BSs to monitor the signal from the handset and report the measurement results back to the network. The network then chooses a new BS for the handover and informs both the handset (through the old BS) and the new BS. The handover is then performed. Mobile-assisted handover (MAHO) is a variant of NCHO where the network asks the handset to measure the signals from surrounding BSs and report the measurements back to the old BS so that the network can determine where a handover is required and to which BS.

In a CDMA system, the entire spectrum is used by each BS. During the handover procedure the handset commences communication with a new BS without interrupting communication with the old BS. In this *soft handover* [12], an identical frequency is assigned between the old BS and the new one, which provides different-site selection diversity to enhance the signal.

HPCS also needs to handle *tier handover* or the case when a handset switches from one tier to another during the conversation. If the systems do not overlap, tier handover does not occur and the tier handover issue does not exist. For the microcell/macrocell architecture in SRSN, both macrocell and microcell systems follow the same air interface and network signaling protocol. Thus, tier handover is exactly the same as the normal handover in a single system.

For SRSN with the different frequency bands, the integrated systems are exactly the same except for the frequency bands at which the systems operate. Thus, we anticipate that tier handover is not as simple as this for the microcell/macrocell architecture, but is not difficult to implement.

For DRSN, it is clear that modifications are required to perform tier handover. Soft handover in IS-95 is clearly not compatible with the hard handover in AMPS. Also, the MAHO/TDMA handover in IS-54 is not compatible with the MCHO/FDMA handover in AMPS. When an IS-95 or IS-54 traffic channel is switched to an AMPS traffic channel, a modified MCHO/FDMA handover is executed. In the current IS-95 implementation, it is possible to perform handover from IS-95 to AMPS, but not the reverse.

For DRDN, tier handover is almost impossible. First of all, the integrated systems may use different handover approaches. For example, AMPS follows NCHO and PACS follows MCHO. Similarly, GSM follows MAHO and DECT follows MCHO. To perform tier handover just like a normal handover, the handover procedures for both integrated systems must be *significantly* modified for HPCS such as AMPS-PACS and GSM-DECT. Even if the handover approaches are similar for the integrated systems (e.g., in AMPS-CT2+¹ both systems use NCHO), the implementations are typically very different. The best offer is probably to have the DRDN network to automatically redial and reconnect the call during tier handover. For example, when a handset intends to move from low tier to high tier during the conversation, the DRDN disconnects the call at the low tier following the standard call release procedure, and then reconnects the call at the high tier following the standard call setup procedure. It is not clear if the long tier handover time is justified.

REGISTRATION FOR SRSN/DRSN

The most important HPCS implementation issue is *roaming management*. Three aspects (registration, call delivery, and handset identity) of HPCS roaming management are discussed in this and the subsequent sections.

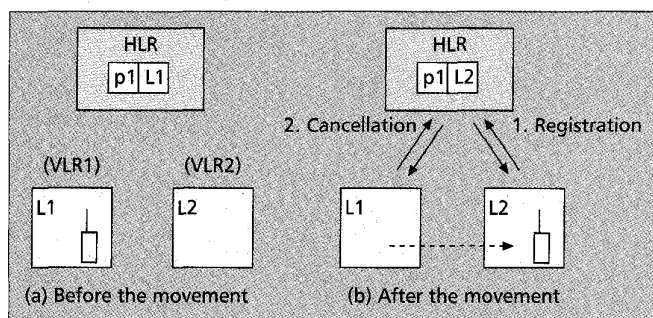

■ Figure 2. The IS-41 registration procedure.

We use IS-41 as an example to describe HPCS roaming management. The HPCS may use other network protocols such as GSM or both IS-41 and GSM in the individual systems. We first describe the IS-41 registration procedure, and then show how IS-41 can be modified to accommodate HPCS.

In a PCS system, the service area is partitioned into several registration areas (RAs), and each RA covers several cells. When the user first subscribes to the PCS service, a permanent record of the user is created at a database, the HLR. Since the user may move from one RA to another, the location of the handset carried by the user must be identified before any communication connection can be established. The current location or RA of a handset is usually maintained by a two-level hierarchical strategy with HLR and another type of database, the VLR. A VLR is the location register used to retrieve information for handling calls to or from a visiting mobile user. A VLR may cover several RAs. For demonstration purposes, this article assumes that every VLR covers exactly one RA, and the terms VLR and RA are used interchangeably. Figure 2 illustrates the IS-41 registration procedure. Suppose that handset p_1 is in the VLR L1. This location is then recorded at the HLR, as shown in Fig. 2a. When p_1 moves to VLR L2, it registers at L2. The VLR L2 then informs p_1 's HLR of the address of the current visited VLR (i.e., L2; Fig. 2b). The HLR sends a cancellation message to the old VLR (i.e., L1) to cancel the obsolete VLR record. Following this registration procedure, the HLR always knows the location of the VLR where the handset is currently registered. In HPCS, particularly DRDN, the network may need to identify the individual PCS system besides the VLR address within the system. For SRSN and DRSN, there is no need to identify the individual system, and the standard IS-41 procedure can be used for HPCS without any modifications:

- For SRSN, heterogeneous BSs (operating at different power levels or different frequency bands) may connect to the same MSCs following the same network signaling protocol. Thus, from the viewpoint of the MSCs, these BSs can be treated in the same way (i.e., heterogeneous BSs can be controlled by the same VLR).
- For DRSN, it is more likely that heterogeneous BSs are grouped into different VLRs. Since the structures of the VLRs and HLRs are the same for the individual systems, the HLRs can be merged into one HLR, and the VLRs from different systems can talk to the single HLR using the standard IS-41 protocol.

If the handset is in an area where more than one individual system is available, either the handset or the network may select the active tier. If the network is responsible for tier selection, modifications to the registration procedure similar to (but simpler than) those for DRDN (see the next section) are required.

¹ CT2+ [13] is an enhanced version of CT2. The original CT2 specification did not include the handover feature.

DRDN REGISTRATION

For DRDN, individual systems use different registration procedures (including authentication), and the information stored in the mobility databases (i.e., VLR and HLR) are different. Thus, modifications to the registration protocols are required to accommodate DRDN. For example, besides VLR and HLR, an access manager (AM) was introduced to PACS, and an alert id for paging is stored in the VLR/AM, which is not found in AMPS. Thus, for PACS/AMPS integration, network protocols must be modified. For a PACS, DECT, or CT2 system that connects to a wireless PBX within a building, handset re-registration may be required to determine whether a handset is still in the system. Re-registration is not required in AMPS or some implementations of GSM (other GSM implementations use re-registration for fault tolerance purposes [14]).

To minimize the cost of DRDN roaming management integration, Chang *et al.* have proposed the multitier HLR (MHLR) approach to integrate the HLRs of the individual systems [15]. It may be difficult to merge the HLRs of DRDN into a single HLR because the formats and operations of the HLRs are different. A reasonable approach is to build a tier manager, which communicates with the heterogeneous HLRs as shown in Fig. 3.

With the MHLR, two registration strategies have been proposed for DRDN. For demonstration purposes, we consider a two-tier DRDN system that consists of a low-tier PCS system such as PACS and a high-tier PCS system such as AMPS.

SINGLE REGISTRATION (SR)

The handset is allowed to register with the MHLR on only one tier at any given time. In a two-tier system, if the low tier

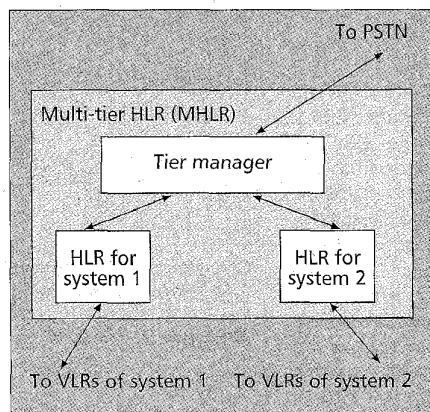

■ Figure 3. The multitier HLR.

reasonable to assume that L1 and L2 are covered by H1.

The handset p_1 moves from H1 to L1 (Fig. 4b), from L1 to H1 (Fig. 4c), and then from H1 to L2 (Fig. 4d). The SR protocol mimics standard registration protocols such as IS-41. Thus, when p_1 moves from one tier to another, a registration operation is performed at the new tier and a deregistration (cancellation) operation is performed at the old tier (Fig. 4b, c, and d).

MULTIPLE REGISTRATION (MR)

The handset is allowed to register with the MHLR on multiple tiers concurrently at any given time. In MR, the individual tiers perform their own roaming management as if they are not integrated. The tier manager of the MHLR keeps track of the currently (or most recently) visited high-tier and low-tier VLRs of a handset. Figure 5 illustrates how MR works.

At Step 1 (Fig. 5a), p_1 is in H1 and the most recently visited low tier VLR is L1. Thus, at Step 2 (Fig. 5b), when p_1 moves back to L1, no registration operation is performed. Similarly, no action is taken at Step 3 (Fig. 5c), and the registration operation is performed at Step 4 (Fig. 5d) when the currently visited low-tier VLR (L2) is different from the latest visited VLR (L1). Figures 4 and 5 indicate that MR generates less registration traffic than SR does.

HPCS CALL DELIVERY

For the HPCSs that use IS-41 or SR, the call delivery procedure follows the IS-41 protocol, as illustrated in Fig. 6. Suppose that a wireline user dials the mobile identification number (MIN) of the handset p_1 . The call is set up using the following steps:

Step 1 — The originating switch queries the HLR (or the MHLR) to find the location of p_1 . Based on the location record, the HLR (MHLR) queries the VLR for the routing information.

Step 2 — The VLR returns the routable address (of the MSC where p_1 locates) back to the originating switch via the HLR (MHLR).

Step 3 — The originating switch sets up the trunk to the MSC based on the routable address. The handset p_1 is paged, and the conversation starts.

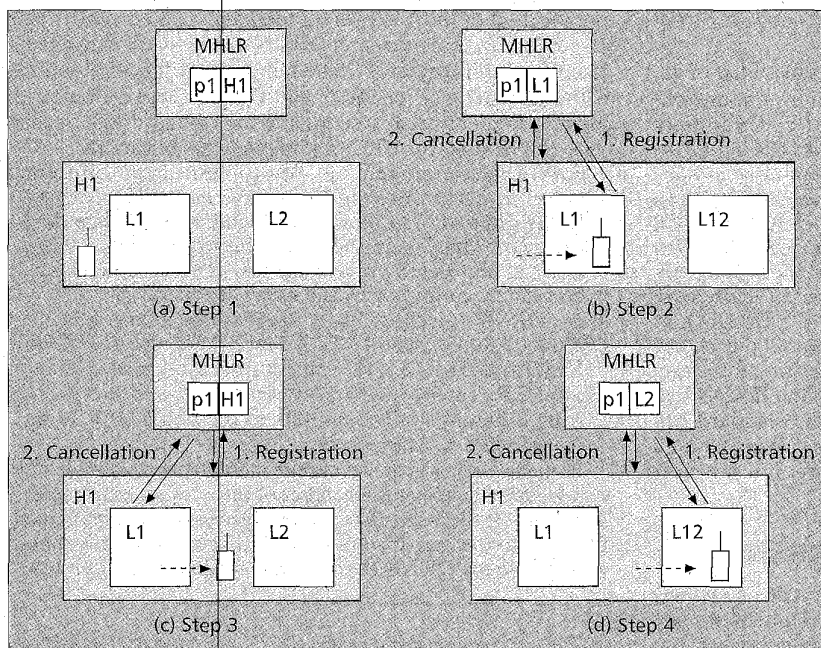

■ Figure 4. The single registration protocol.

For the HPCSs that use MR, the MHLR does not know the current tier where p_1 resides. Thus, the network selects a tier for call delivery based on some heuristics. If this fails (i.e., the first try selects the wrong tier), the network then tries another tier. The call delivery procedure is illustrated in Figs. 7 and 8.

Steps 1–3 of MR (Fig. 7) are the same as those of IS-41/SR except that MHLR needs to select a tier at Step 1. After the trunk is set up at Step 3, the network may realize that the handset is not in the selected tier. If so, the setup trunk must be released (Step 4 in Fig. 8), and the same call delivery procedure (Steps 5–7 in Fig. 8) is performed for the other tier.

It is clear that if the MHLR selects the wrong tier, the penalty is very high. To reduce the penalty, the handset may be paged at Step 1 of the call delivery procedure when the VLR is queried. If the handset is not found, the MHLR then tries the other tier before it returns the routable address to the originating switch (Steps 3 and 4 in Fig. 9).

Note that PACS is the only PCS system that pages the handset at the VLR query step in the call delivery procedure. For other PCS systems, to page the handset before the routable address is returned, the call delivery procedure must be modified.

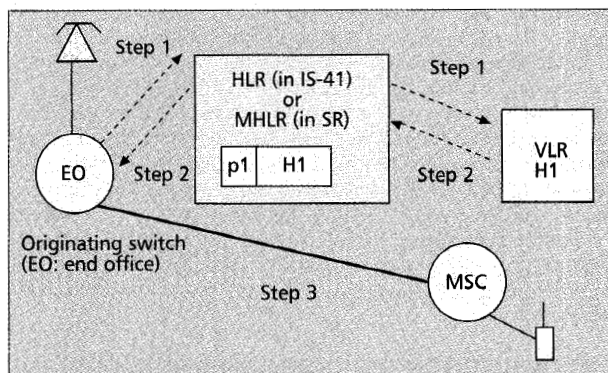

■ Figure 6. The call delivery procedure (IS-41, SR).

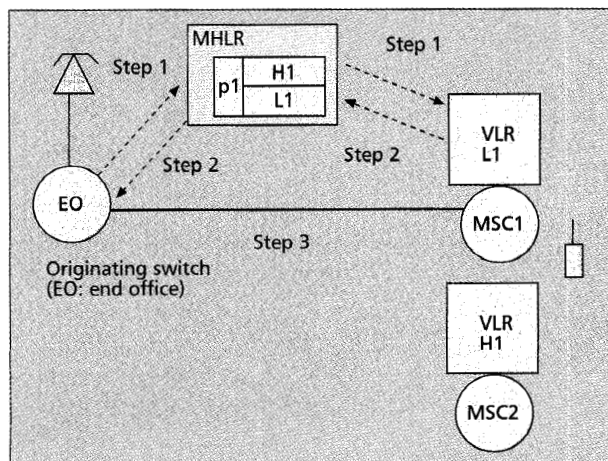

■ Figure 7. The call delivery procedure (MR).

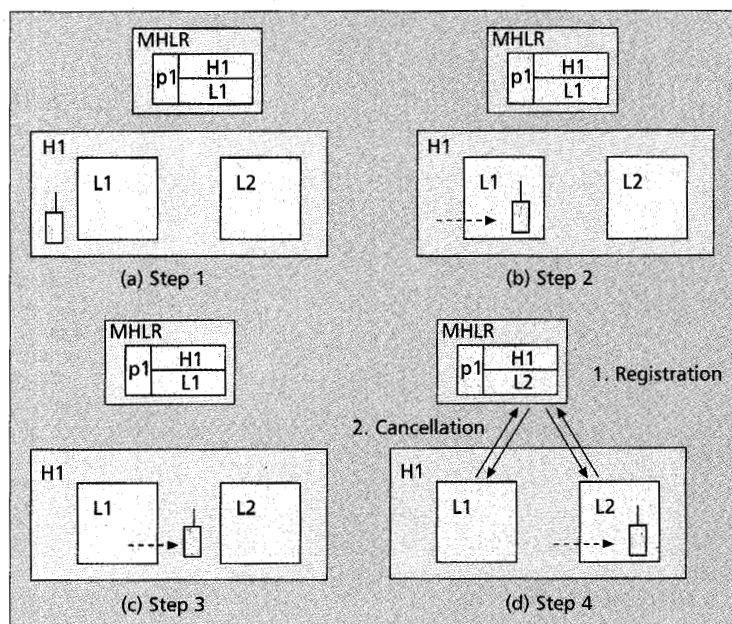

■ Figure 5. The multiple registration protocol.

USER IDENTITIES AND HPCS HANDSETS

An HPCS user may have a single identity or multiple identities. To accommodate multiple user identities, different identification numbers should map to the same HLR record. The mapping can be implemented with the concept of the MHLR: the mapping function is performed at the tier manager, and the individual HLRs do not need to be modified.

For microcell/macrocell SRSN, the user only has one identity and one handset. For DRSN and DRDN, an HPCS user may carry multiple handsets or a multimode handset. A PCS user may already own handsets for different PCS services. If the user would like to order the HPCS that integrates the already subscribed PCS services, it is probably more economical to keep the original multiple handsets. There are two other reasons that multiple handsets are used in HPCS.

- An HPCS may consist of more than two PCS systems, and the service provider may offer any arbitrary combi-

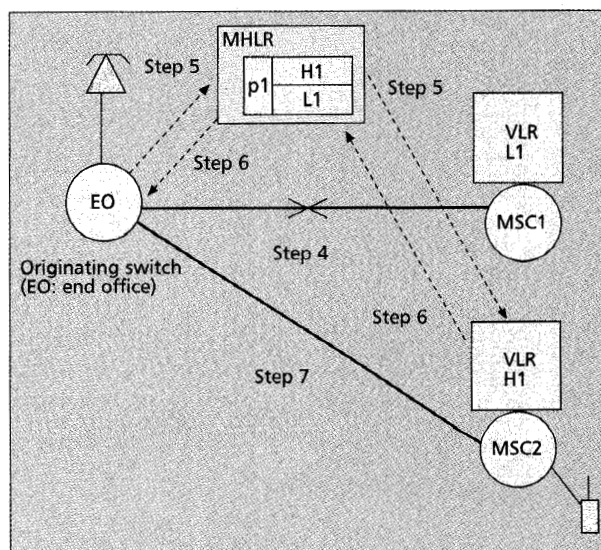

■ Figure 8. The call delivery procedure (MR) continued.

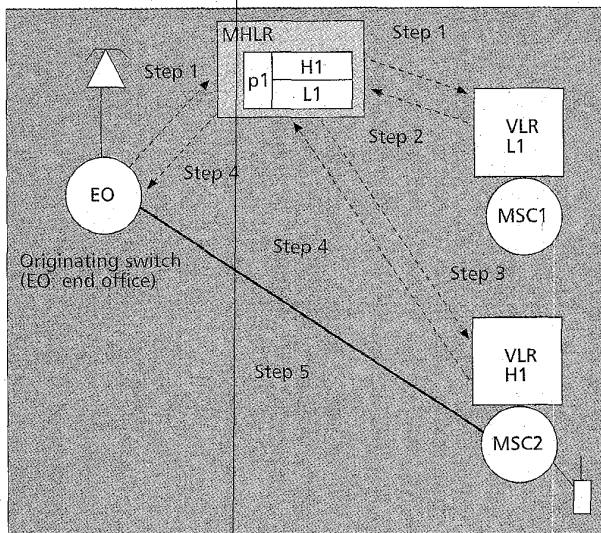

■ **Figure 9.** The call delivery procedure for MR: paging before returning the routable address.

nation of these PCS systems upon request of a user. In this case, it may not be cost effective to manufacture multimode handsets for all possible combinations (especially when a user may drop/add PCS systems).

- An HPCS may include special-purpose PCS systems. For example, a wireless LAN-based PCS system in a building may offer a high channel bit rate for video or mobile computing services. A high-bit-rate videophone for the system is useless when the user leaves the building, and it may not be appropriate to integrate the (heavy) videophone with a (light and simple) handset used for other PCS systems.

If multiple handsets are used, it is typically the user's responsibility to select the tier (turn on the handset of the active tier and turn off the handsets of the idle tiers). If the network is responsible for tier selection, MR is probably a more reasonable choice than SR.

In terms of roaming management, it makes sense to develop multimode handsets for HPCS. IS-54/AMPS and IS-

95/AMPS dual-mode handsets are required in the IS-54 and IS-95 specifications. DECT/GSM dual-mode handsets have been developed for in-building (DECT) and out-of-building (GSM) usage. A switch may be provided in the multimode handset for the user to manually select the tier. Or the handset may be intelligent enough to implement SR or MR. Figure 10 shows the flow chart of an SR handset. In this flow chart, the handset stays in the low tier if it is available (Steps 1, 2, and 3 in Fig. 10). If the low tier is not available but the high tier is, the handset stays in the high tier until the low tier is available again (Steps 4, 5, and 6 in Fig. 10).

Figure 11 illustrates the flow chart for an MR handset. In this flow chart, the handset monitors both the low tier (Steps 1, 2, and 3 in Fig. 11) and the high tier (Steps 4, 5, and 6) at the same time. Note that the flow charts for both SR and MR are very similar, which implies that it is easy to implement the two registration approaches in a handset (just add two or three lines in the micro kernel of the handset).

FINAL REMARKS

This article has described heterogeneous PCS systems and their evolution into HPCS. HPCS development has been motivated by business needs. One telephony industry trend is wireless business consolidations to create stronger regional/national market coverage (e.g., AT&T's acquisition of McCaw's cellular operations, cellular operations merging of Bell Atlantic and NYNEX, and the merging of US West and AirTouch). After consolidations, the PCS operating companies will own PCS systems of the same or different cellular/cordless technologies, which will be either overlapping or disjoint. Integrating different PCS systems to provide a universal PCS service to the users will be necessary. One of the most important technical issues is to minimize the extra signaling traffic generated by tier management. Performance modeling of HPCS is still at its early stage. On the other hand, a major business issue is the integration of PCS systems owned by different service providers. There is no conclusion regarding a billing platform for tier switching. We anticipate that exciting HPCS stories will continue in the following years.

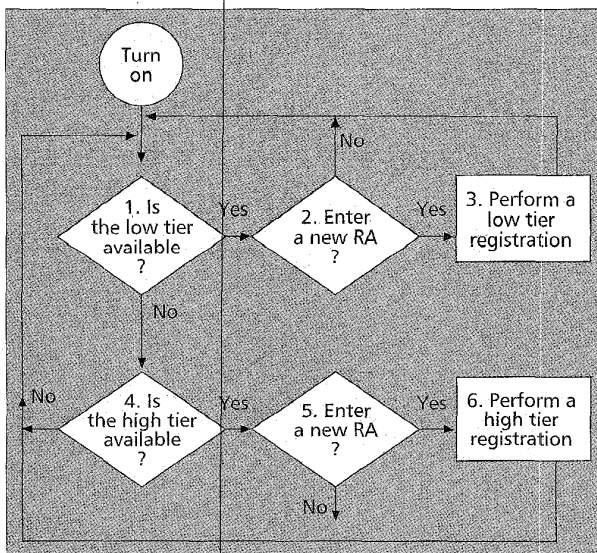

■ **Figure 10.** The SR handset.

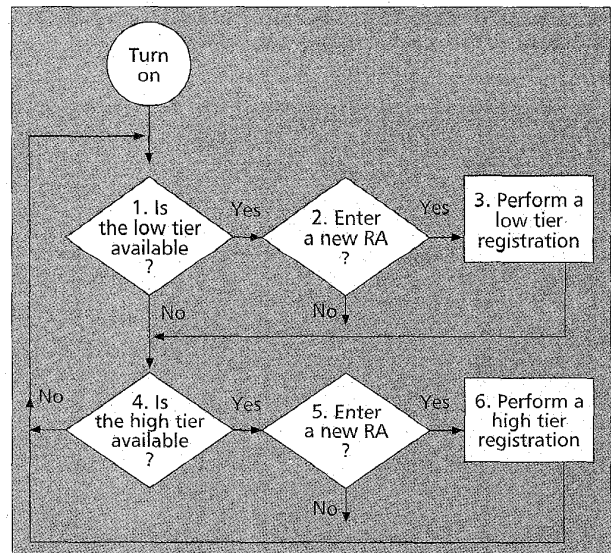

■ **Figure 11.** The MR handset.