

### Corrections to "Reinforcement Learning for an ART-Based Fuzzy Adaptive Learning Control Network"

Cheng-Jian Lin and Chin-Teng Lin

In the above paper,<sup>1</sup> the graphics for Figs. 3, 5, and 6 were printed incorrectly due to a publisher error. The correct figures are as follows.

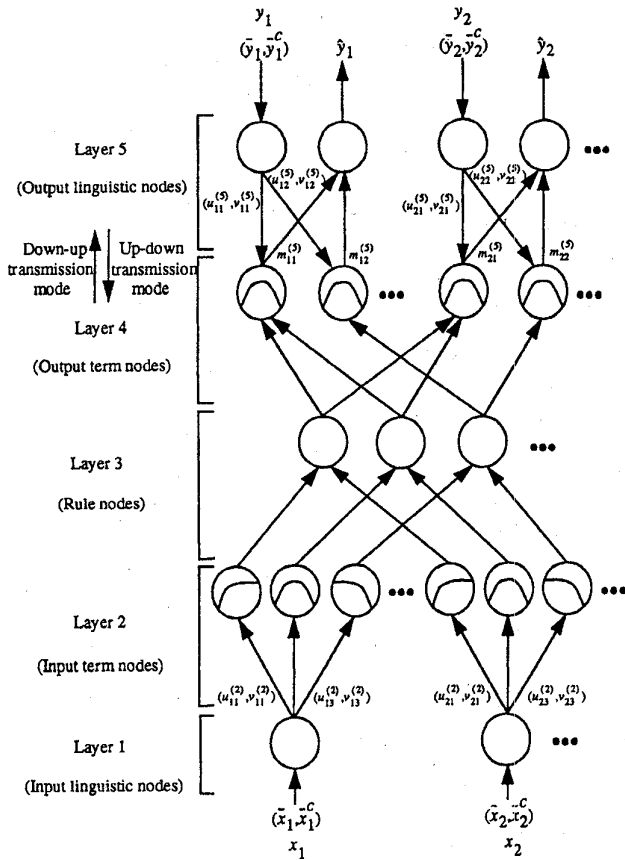

Fig. 3. The proposed FALCON.

Manuscript received July 1, 1996.

The authors are with the Department of Control Engineering, National Chiao-Tung University, Hsinchu, Taiwan, R.O.C.  
 Publisher Item Identifier S 1045-9227(96)08055-1.

<sup>1</sup>C.-J. Lin and C.-T. Lin, *IEEE Trans. Neural Networks*, vol. 7, pp. 709-731, May 1996.

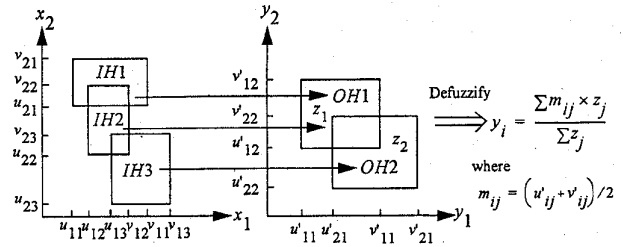

Fig. 5. The fuzzy reasoning process in the FALCON model.

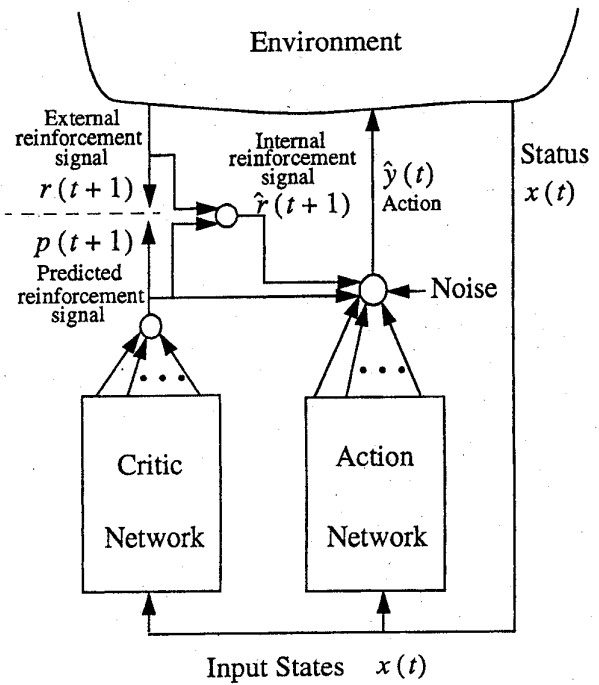

Fig. 6. The proposed RFALCON.