

(a)

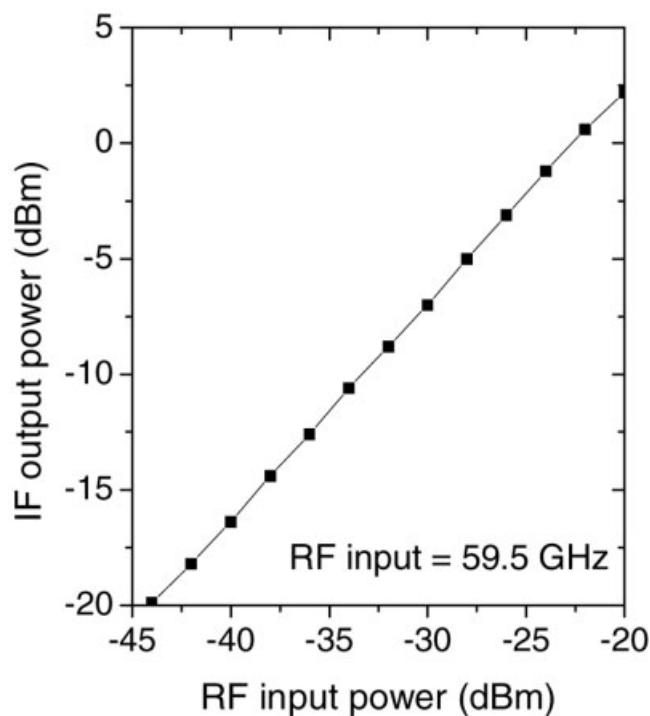

(b)

**Figure 5** Measured output power of the transceiver module: (a) transmitter; (b) receiver

sion point is 16 dBm. The conversion gain of the receiver is 23.4 dB.

#### 4. CONCLUSION

A small size 60-GHz full duplex transceiver module is developed for high data rate millimeter wave wireless access link. The sub-

strate integrated planar 60-GHz BPF and the simple broadband coplanar ribbon-bond interconnects enable a compact and low cost realization of the transceiver module. The planar three-pole Chebyshev filter using a new type of IWG transition shows an insertion loss of 3 dB and a 2.4% bandwidth at the center frequency of 61.5 GHz and the coplanar ribbon-bond interconnect exhibits low loss of 0.2 dB over DC to 70 GHz. The RF output power of the module is 16 dBm at 1 dB compression with conversion gain of 30.6 dB and the conversion gain of the receiver is 23.4 dB. The overall size of the module is 50 mm × 75 mm × 23 mm.

#### ACKNOWLEDGMENT

The authors thank Millisys and OKI Electric Industry (through the FAMN project) for supporting this work.

#### REFERENCES

1. S.T. Choi, K.S. Yang, K. Tokuda, and Y.H. Kim, A V-band planar narrow bandpass filter using a new type integrated waveguide transition, *IEEE Microw Wireless Comp Lett* 14 (2004), 545–547.
2. I. Gresham, N. Jain, T. Budka, A. Alexanian, and N. Kinayman, A manufacturable 76–77 GHz radar module for commercial ACC applications, *IEEE Trans Microwave Theory Tech* 49 (2001), 44–58.
3. K. Ohata, Millimeter-wave monolithic GaAs IC interconnect and packaging technology trends in Japan, *GaAs IC Symp Dig* (1999), 105–108.
4. T. Budka, Wide-bandwidth millimeter-wave bond-wire interconnects, *IEEE Trans Microwave Theory Tech* 49 (2001), 715–718.
5. S.T. Choi, K.S. Yang, S. Nishi, S. Shimizu, K. Tokuda, and Y.H. Kim, A 60-GHz point-to-multipoint millimeter-wave fiber-radio communication system, *IEEE Trans Microwave Theory Tech* 54 (2006), 1953–1960.
6. W.H. Haydl, On the use of vias in the conductor-backed coplanar circuits, *IEEE Trans Microwave Theory Tech* 50 (2002), 1571–1577.
7. Y.C. Leong and S. Weinreb, Full band waveguide-to-microstrip probe transitions, *IEEE MTT-S Int Symp Dig* (1999), 1435–1438.

© 2007 Wiley Periodicals, Inc.

## HIGH-GAIN HIGH-ISOLATION CMFB STACKED-LO SUBHARMONIC GILBERT MIXER USING SiGe BiCMOS TECHNOLOGY

T. H. Wu,<sup>1</sup> C. C. Meng,<sup>1</sup> and G. W. Huang<sup>2</sup>

<sup>1</sup>Department of Communication Engineering, National Chiao Tung University, Hsinchu 300, Taiwan, R.O.C.

<sup>2</sup>National Nano Device Laboratory, Hsinchu 300, Taiwan, R.O.C.

Received 25 September 2006

**ABSTRACT:** A 5.2-GHz SiGe BiCMOS stacked-LO-stage CMFB (common mode feedback) subharmonic mixer is demonstrated in this article. The stacked-LO-stage and the active loads are used to improve the 2LO-RF isolation and the conversion gain, respectively. The SiGe mixer includes five levels of transistors stacked together at the supply voltage of 3.3 V because of the low knee-voltage characteristic of the SiGe HBTs (heterojunction bipolar transistors). The mixer demonstrated achieves 23 dB conversion gain and –78 dB 2LO-RF isolation. © 2007 Wiley Periodicals, Inc. *Microwave Opt Technol Lett* 49: 1214–1216, 2007; Published online in Wiley InterScience (www.interscience.wiley.com). DOI 10.1002/mop.22398

**Key words:** subharmonic mixer; stacked-LO-stage; SiGe heterojunction bipolar transistor (HBT); 2LO-RF isolation; Gilbert mixer

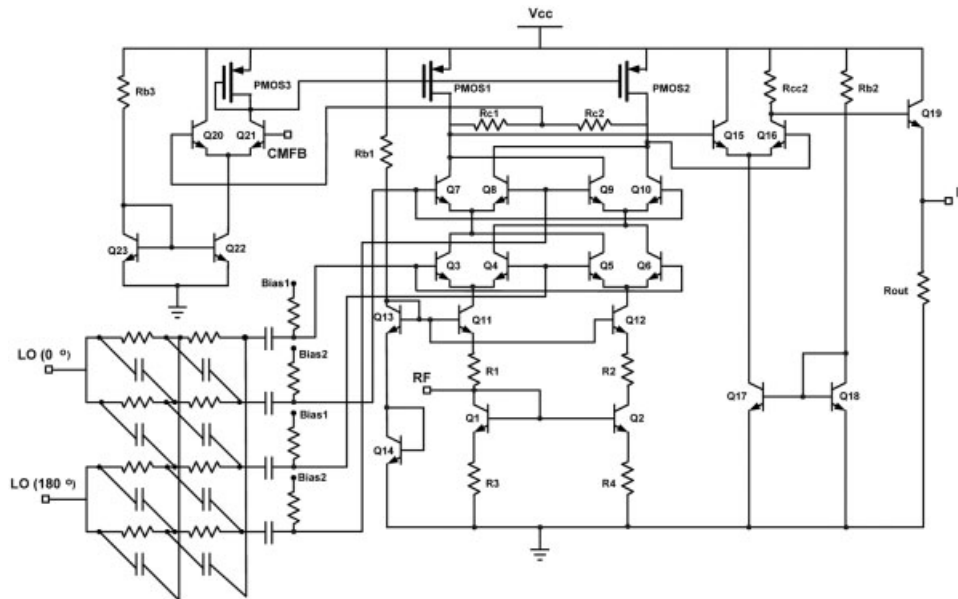

**Figure 1** The circuit schematic of the 5.2-GHz stacked-LO Gilbert subharmonic mixer using SiGe BiCMOS technology.

## 1. INTRODUCTION

The traditional Gilbert topology suffers from the high LO-to-RF leakage that causes the self-mixing and DC offset problems in the direct-conversion application. To prevent the leakage and improve the RF performance, the micromachining technique has become popular for RFIC designs [1, 2]. On the other hand, the subharmonic mixer topologies are proposed to directly eliminate the LO leakage. There are many subharmonic mixer topologies to suppress the LO-to-RF leakage [3–5]. One of the most useful subharmonic mixer topologies is the three-level stacked-LO scheme [3, 4]. However, the stacked-LO-stage consumes more headroom. Figure 1 shows the circuit schematic of the stack-LO SiGe BiCMOS subharmonic mixer. Because of the low knee-voltage characteristic of SiGe HBTs, a 5.2-GHz SiGe BiCMOS subharmonic stacked-LO-stage down-conversion micromixer using active loads to increase the conversion gain is demonstrated in this article. The mixer demonstrated here is stacked with five transistor levels: two levels for the micromixer input stage [6, 7], two levels for the stacked-LO stage, and one level for PMOS loads.

## 2. CIRCUIT DESIGN

The circuit schematic of the demonstrated SiGe BiCMOS stacked-LO-stage subharmonic mixer is shown in Figure 1. The RF and the LO input frequency of the mixer are 5.201 and 2.6 GHz, respectively. The RF micromixer input stage consists of transistors  $Q_1$ ,  $Q_2$ ,  $Q_{11}$ , and  $Q_{12}$ , and resistors  $R_1$  to  $R_4$ . The micromixer input stage basically is an active balun used to generate differential RF currents and can also perform input impedance matching. The stacked-LO-stage of the subharmonic mixer is composed of transistor pairs  $Q_3$  to  $Q_6$  and  $Q_7$  to  $Q_{10}$ . The function of the stacked-LO stage is equivalent to a Gilbert cell that mixes down the RF frequency with  $2LO$  frequency. The stacked-LO-stage subharmonic mixer translates the RF input frequency down to IF frequency with quadrature LO signals, which are generated from a two-section passive polyphase filter. The balanced circuit topology and the stacked-LO Gilbert stage produce the low  $2LO$ -RF leakage. In addition, the SiGe BiCMOS technology used in this work provides deep trench isolation to reduce the signal coupling among

devices. The loading network of the demonstrated mixer is an active PMOS load to increase the conversion gain; therefore, it requires a CMFB circuit to stabilize the bias voltage of the active load. The CMFB circuit formed by a differential pair consists of transistor  $Q_{20}$  and  $Q_{21}$ , and the sensing resistors  $R_{C1}$  and  $R_{C2}$ . An output buffer consisting of a differential pair and an emitter follower is employed to combine the differential IF signals and perform the output impedance matching. The die photo is shown in Figure 2. The 2.6-GHz LO differential GSGSG pads are on the left followed by a two-section passive polyphase filter, while the IF

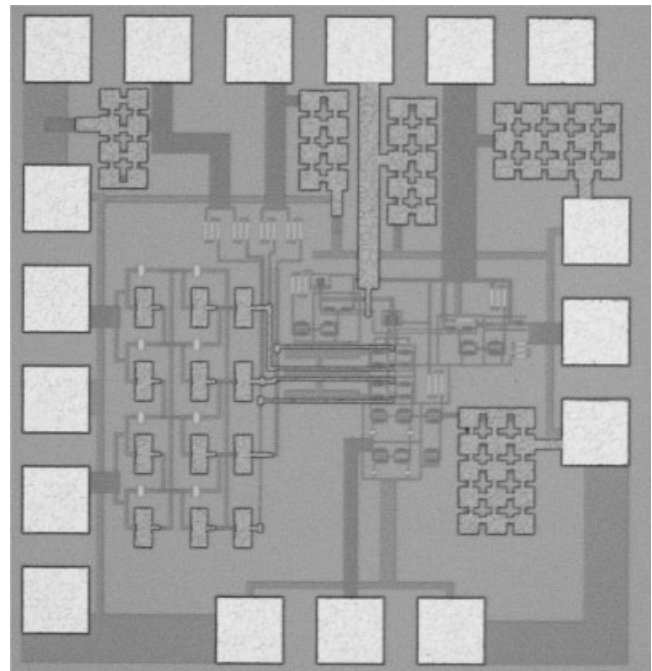

**Figure 2** The die photo of the 5.2-GHz stacked-LO Gilbert subharmonic mixer using SiGe BiCMOS technology

output GSG pads are on the right. The RF input pads are on the bottom and there are 6-pin DC pads on the top of the chip. The total die size is  $0.9 \times 0.97 \text{ mm}^2$  including the probing pads. The transistor  $f_T$  is 67 GHz with 2 V  $BV_{CEO}$ . The emitter areas of the transistors used here are  $0.3 \mu\text{m} \times 9.9 \mu\text{m}$  for the mixer core and the output buffer.

### 3. MEASUREMENT RESULTS

The supply voltage of the demonstrated mixer is 3.3 V, and the current consumption is 5 mA including the output buffer. Figure 3 shows the measured conversion gain and the DSB (double side band) noise figure as a function of frequency when the LO pumping power is  $-4 \text{ dBm}$ . As shown in Figure 3, the conversion gain is 23 dB and the 3-dB IF bandwidth of the mixer is about 145 MHz. The measured DSB noise figure in its IF bandwidth is 20 dB. According to the measured noise figure, the  $1/f$  noise corner does not appear for the IF frequency down to 1 MHz. The major reason can be contributed to SiGe HBTs that have lower phase noise compared with CMOS transistors [8]. In addition, the  $0.35 \mu\text{m}$  PMOS transistors as active loads are buried channel devices and have good flicker noise performance. Therefore, the  $1/f$  noise figure corner is lower than 1 MHz. The power performance of the stacked-LO subharmonic micromixer when the RF frequency is 5.201 MHz and the LO power is  $-4 \text{ dBm}$  is shown in Figure 4. The measured  $IP_{1 \text{ dB}}$  and the  $IIP_3$  are  $-37$  and  $-23 \text{ dBm}$ , respectively. When the RF frequency is 5.2 GHz, the RF input return loss is  $-11 \text{ dB}$ . The 2LO-RF leakage power is  $-82 \text{ dBm}$ ; therefore, this stacked-LO structure provides near  $-78 \text{ dB}$  isolation when the LO frequency is 2.6 GHz and the 2LO frequency is 5.2 GHz. This excellent 2LO-RF isolation results from the stacked-LO stage and the balanced circuit topology. The port-to-port isolations are also measured, and the LO-to-IF isolation is  $-52 \text{ dB}$ , the LO-to-RF isolation is  $-49 \text{ dB}$  and the RF-to-IF isolation is  $-34 \text{ dB}$ .

### 4. CONCLUSION

A 5.2-GHz high 2LO-RF isolation stacked-LO stages subharmonic micromixer using SiGe BiCMOS technology is demonstrated. Active PMOS loads to increase the conversion gain with CMFB circuits are used in this work. This mixer contains five levels of active devices stacked together. The 2LO-RF isolation of the mixer is  $-78 \text{ dB}$  and the conversion gain is 23 dB.

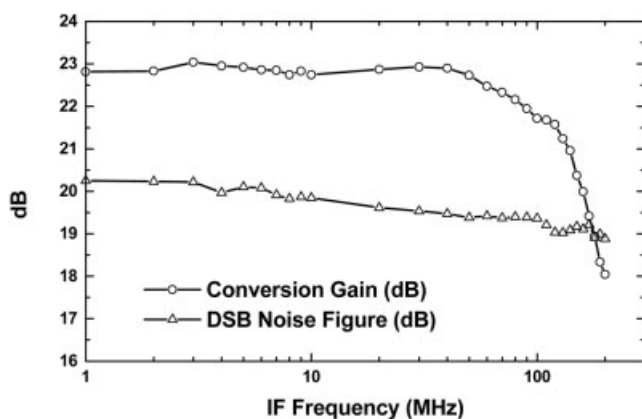

**Figure 3** The measured conversion gain and the DSB noise figure of the 5.2-GHz stacked-LO Gilbert subharmonic mixer using SiGe BiCMOS technology

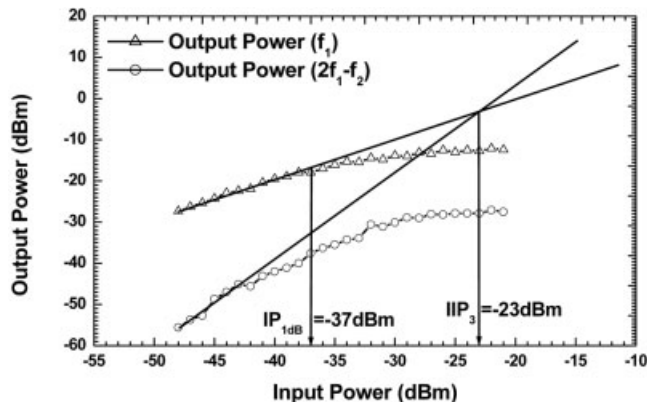

**Figure 4** The measured  $IP_{1 \text{ dB}}$  and  $IIP_3$  of the 5.2-GHz stacked-LO Gilbert subharmonic mixer using SiGe BiCMOS technology

### ACKNOWLEDGMENTS

This work is supported by National Science Council of Taiwan, Republic of China under contract numbers NSC 95-2752-E-009-001-PAE, NSC 95-2221-E-009-043-MY3, by the Ministry of Economic Affairs of Taiwan under contract number 94-EC-17-A-05-S1-020, by MoE ATU Program under contract number 95W803, and by the Chip Implementation Center (CIC).

### REFERENCES

1. T. Wang, H.-C. Chen, H.-W. Chiu, Y.-S. Lin, G.W. Huang, and S.-S. Lu, Micromachined CMOS LNA and VCO by CMOS compatible ICP deep trench technology, *IEEE Trans Microw Theory Technol* 54 (2006), 580–588.
2. H.-C. Chen, C.-H. Chien, H.-W. Chiu, S.-S. Lu, K.-N. Chang, K.-Y. Chen, and S.-H. Chen, A low-power low-phase-noise LC-VCO with MEMS Cu inductors, *IEEE Microw Wireless Compon Lett* 15 (2005), 434–436.
3. J. Choma, Jr., A three-level broad-banded monolithic analog multiplier, *IEEE J Solid-State Circuits*, SC-16 (1981), 392–399.
4. L. Sheng, J.C. Jensen, and L.E. Larson, A wide-bandwidth Si/SiGe HBT direct conversion sub-harmonic mixer/downconverter, *IEEE J Solid-State Circ* 35 (2000), 1329–1337.
5. H.C. Chen, T. Wang, S.S. Lu, and G.W. Huang, A monolithic 5.9-GHz CMOS I/Q direct-down converter utilizing a quadrature coupler and transformer-coupled subharmonic mixers, *IEEE Microw Wireless Compon Lett* 16 (2006), 197–199.
6. B. Gilbert, The MICROMIXER: A highly linear variant of the Gilbert mixer using a bisymmetric Class-AB input stage, *IEEE J Solid-State Circ* 32 (1997), 1412–1423.
7. J. Durec and E. Main, A linear class AB single-ended to differential transconductor suitable for RF circuits, *IEEE MTT-S Digest* 1996, pp. 1071–1074.
8. I. Nam, Y.J. Kim, and K. Lee, Low  $1/f$  noise and DC offset RF mixer for direct conversion receiver using parasitic vertical NPN bipolar transistor in deep N-well CMOS technology, *IEEE Symposium on VLSI circuits*, Digest of Technical Papers, 2003, pp. 223–226.

© 2007 Wiley Periodicals, Inc.