

A Filterbank Approach to Window Designs for Multicarrier Systems*

Yuan-Pei Lin, Chien-Chang Li, and See-May Phoong

Abstract

Windowing is often applied to multicarrier systems to improve frequency separation among the subcarriers. At the transmitter side better frequency separation leads to a smaller out-of-band spectral leakage and also less interference to radio frequency transmission. At the receiver side better separation gives more suppression of radio frequency interference. As these are frequency based characteristics, a filterbank representation presents a natural and useful framework for formulating the problem. In this work, we propose a unified filterbank approach to the design of windows for multicarrier systems. The filterbank viewpoint provides an additional insight into the transmitter design for spectral leakage reduction as well as to the receiver design for interference suppression. A better frequency separation among the subchannels can be achieved.

* This work was supported in parts by NSC 95-2221-E-009-080, NSC94-2752-E-002-006-PAE, and NSC 95-2221-E-002-197, Taiwan, R.O.C.

Introduction

The DFT (discrete Fourier transform) based multicarrier systems have found important applications in DMT (discrete multitone) systems such as ADSL (asymmetric digital subscriber lines) [1] and VDSL (very high speed digital subscriber lines) [2], and in OFDM (orthogonal frequency division multiplexing) systems such as wireless LAN (local area network) [3] and DVB (digital video broadcasting) [4]. The transmitter and receiver perform M -point IDFT (inverse DFT) and DFT computation, respectively, where M is the number of subchannels. At the transmitter side, a cyclic prefix of length ν is inserted. The channel can usually be assumed to be an FIR (finite impulse response) filter of order L after proper time-domain equalization. When the prefix length $\nu \geq L$, there will be no inter-block interference. With the aid of redundant cyclic prefix, an FIR channel is converted into M zero-ISI subchannels. The subchannel gains are the M -point DFT of the FIR channel impulse response.

In the conventional DFT based multicarrier system the transmitting and receiving filters come from rectangular windows. Rectangular windows are known to have large spectral sidelobes and the stopband attenuation is insufficient for many applications. At the transmitter side poor frequency separation leads to significant spectral leakage. This could pose a problem in applications where the spectrum of the transmitted signal is required to have a large roll-off in certain frequency bands. For example, in some wired transmission application, the spectrum of the transmitted signal needs to fall below a threshold in the transmission bands of the opposite direction to avoid interference [1], [2]. The transmitted spectrum should also be attenuated in amateur radio bands to reduce interference or egress emission [2]. On the other hand, poor frequency separation at the receiver side results in poor out-of-band rejection. In DMT applications such as ADSL

and VDSL, some of the frequency bands are also shared by radio transmission systems, e.g., amplitude-modulation stations and amateur radio. The radio frequency signals can be coupled into the wires and this introduces radio frequency interference (RFI) or ingress [5]. Ill frequency separation means many neighboring tones can be affected. The signal-to-interference-noise ratio of these tones are reduced and the total transmission rate decreased.

Many methods have been proposed to improve the frequency characteristics of the transmitter and receiver. To improve the spectral roll-off of the transmitted signal, a number of continuous-time pulse shaping filters have been proposed, [6]–[11]. Usually continuous-time pulse shapes are designed based on an analog implementation of transmitters and a digital implementation is not admitted [12]. Discrete-time windows have been considered in [13]–[15]. The design of overlapping windows for OFDM with offset QAM (quadrature amplitude modulation) over ISI free channels are studied fully in [14], [15]. More recently, transmitting windows with the cyclic-prefixed property have been considered in [16], [17] for egress control. Windows that are the inverse of a raised cosine function are optimized in [16], to minimize egress emission. To compensate for the transmitter window, the corresponding receiver requires post-processing equalization [16], [17]. A joint consideration of spectral roll-off and SNR degradation due to post-processing is given in [17]. Per-tone windows are proposed in [18] for shaping transmitted spectrum. The shaping of spectrum allows more tones to be used for transmission.

Windowing is also often applied at the receiver side. In [19], Muschallik used Nyquist windows, which have the property that shifts of the window in the time domain add to a constant, to improve the reception of OFDM systems. Optimal Nyquist windows are considered in [20] to mitigate the effect of additive noise and carrier frequency off-

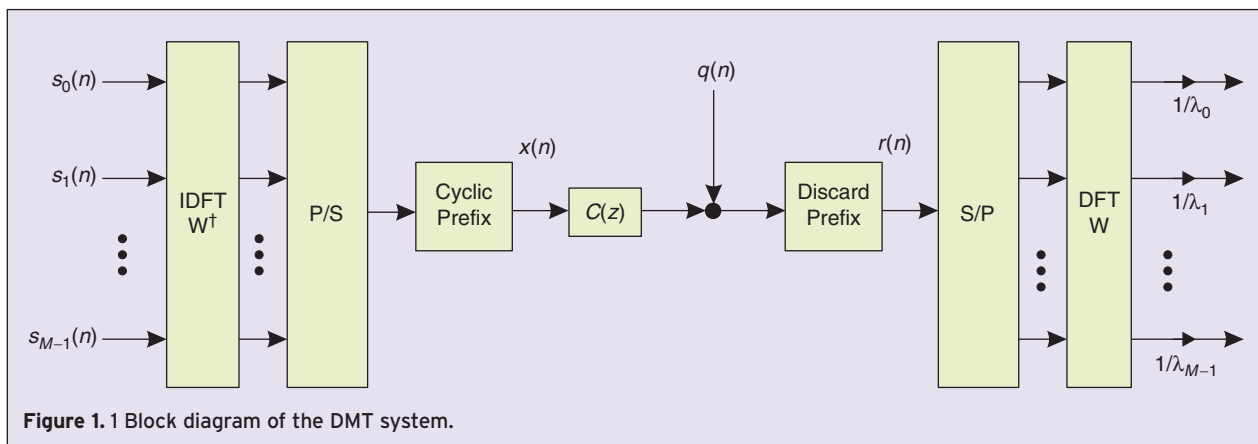

Yuan-Pei Lin and Chien-Chang Li are with the Dept. Electrical and Control Engr., National Chiao Tung Univ., Hsinchu, Taiwan, R.O.C. and See-May Phoong is with the Dept. of EE & Graduate Inst. of Comm. Engr., National Taiwan Univ., Taipei, Taiwan, R.O.C., smp@cc.ee.ntu.edu.tw

sets. To improve RFI suppression, receiver windowing is proposed first in [21] by Spruyt et al. For the suppression of sidelobes without using extra redundant samples, it is suggested in [22] to use windows that introduced controlled IBI, later removed using decision feedback. Joint consideration of RFI and channel noise is considered in [23]; the optimal window can be found using the statistics of the RFI and noise. Using statistics of channel noise and RFI, a joint design of the TEQ and the receiving window for maximizing bit rates is given in [24].

In this work, we propose a unified filterbank framework for the design of windows for multicarrier systems. The approach used here will be more general: we will introduce the so-called *subfilters*. The use of subfilters will enhance the frequency selectivity of the transmitting/receiving filters while maintaining the orthogonality among the subchannels. Correspondingly, for the transmitter side spectral leakage can be reduced and for the receiver side RFI can be further suppressed. When the subfilters form a DFT bank, they can be tied nicely to the conventional windowing. The windows can be optimized through the design of subfilters and frequency separation among the subchannels can be considerably improved.

DMT Systems

The block diagram of the DMT system is as shown in Figure 1. After proper time-domain equalization (if

necessary), the channel is modeled as an FIR filter $C(z)$ of order L with additive noise $q(n)$. The modulation symbols to be transmitted are first blocked into vectors of size M , where M is the number of subchannels, usually much larger than the channel order L . The inputs of the transmitter are modulation symbols. They are passed through an M by M IDFT matrix. The outputs are converted to a block of M serial samples by the parallel to serial operation (P/S). Then a cyclic prefix of length ν is inserted by copying the last ν samples of the block to the beginning. The length of the cyclic prefix ν is chosen so that $\nu \geq L$, which ensures that inter-block-interference (IBI) can be removed easily by discarding the prefix at the receiver.

At the receiver, after prefix removal the samples are blocked into $M \times 1$ vectors ('serial to parallel' or S/P operation) for M -point DFT computation. The scalar multipliers $1/\lambda_k$ are also called frequency domain equalizers (FEQ), where λ_k are the M -point DFT of the channel impulse response. The transceiver is ISI free and the receiver is a zero-forcing receiver. The receiver outputs are identical to the inputs of the transmitter in the absence of channel noise.

Filterbank Representation

Let us derive the filterbank representation of a DMT system, which will be useful for later discussion. In Figure 1, the operation 'P/S' followed by the insertion of a cyclic prefix can be viewed as the interconnection of the matrix

Table 1.
Notation and multirate identities.

1. The notation \mathbf{A}^\dagger denotes transpose-conjugate of \mathbf{A} .
2. The notation \mathbf{W} is used to represent the $M \times M$ normalized DFT matrix given by

$$[\mathbf{W}]_{kn} = \frac{1}{\sqrt{M}} W^{kn}, \quad \text{for } 0 \leq k, n \leq M-1, \quad \text{where } W = e^{-j\frac{2\pi}{M}}.$$

3. The notation $[X(z)]_{\downarrow N}$ denotes the N -fold decimation of $X(z)$. In the time domain $Y(z) = [X(z)]_{\downarrow N}$ means $y(n) = x(Nn)$.
4. *Polyphase identity* [25]. The following interconnection is known to be an LTI system with transfer function $T(z) = [C(z)]_{\downarrow N}$.



5. *Noble identities* [25]. Identities for exchanging an LTI filter and an expander/decimator.

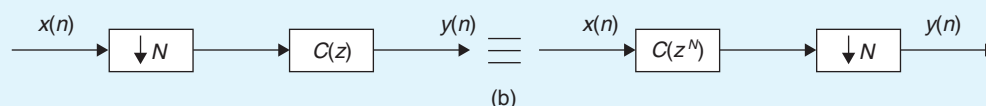
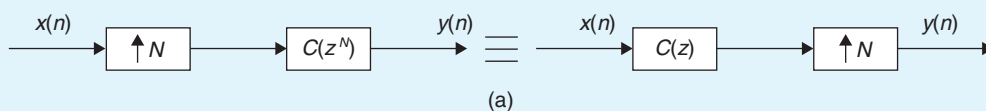

$\begin{pmatrix} \mathbf{0} & \mathbf{I}_v \\ \mathbf{I}_M & \end{pmatrix}$ followed by ‘parallel to serial’ for every $N = M + v$ parallel samples as shown in Figure 2(a). The ‘P/S’ operation is represented using expanders and a delay chain in the figure. On the other hand, the operation ‘discard prefix’ followed by ‘serial to parallel’ and M -point DFT for every M samples in Figure 1 can be viewed as ‘serial to parallel’ for every N samples followed by the matrix $(\mathbf{0} \ \mathbf{W})$ as shown in Figure 2(a), where \mathbf{W} is the normalized DFT matrix defined in Table 1. Thus the transmitter and receiver can be redrawn as in Figure 2(a), where we have combined the two matrices at the transmitter as one matrix \mathbf{G} .

As \mathbf{G} is a constant matrix, we can exchange \mathbf{G} and the expanders; the resulting transmitter is as shown in Figure 2(b). Similarly, we can exchange $(\mathbf{0} \ \mathbf{W})$ and the decimators to yield the receiver shown in Figure 2(b). Note that the $1 \times M$ system from $\mathbf{p}(n)$ to $x(n)$ is LTI. Let’s call the $1 \times M$ transmitting bank $\mathbf{f}(z)$, then $\mathbf{f}(z)$ is a row vector given by $(1 \ z^{-1} \ \dots \ z^{-(M-1)}) \mathbf{G}$. Each element of the row vector can be obtained by multiplying out this expression. Suppose that the k -th element is $F_k(z)$ (k -th transmitting filter), we have

$$F_k(z) = \frac{1}{\sqrt{M}} \sum_{i=0}^{M-1} W^{-(i-v)k} z^{-i}, \quad \text{where } W = e^{-j2\pi/M}. \quad (1)$$

Then the transmitter in Figure 2(b) can be redrawn as in Figure 3. Now consider the receiver side. Denote the $M \times 1$ system from $r(n)$ to $\mathbf{v}(n)$ in Figure 2(b) as $\mathbf{h}(z)$. We can write $\mathbf{h}(z)$ as $\mathbf{h}(z) = (\mathbf{0} \ \mathbf{W})(1 \ z \ \dots \ z^{N-1})^T$. Suppose that the k -th element is $H_k(z)$ (the k -th receiving filter), then we have

$$H_k(z) = \frac{z^v}{\sqrt{M}} \sum_{i=0}^{M-1} W^{ik} z^i. \quad (2)$$

We can redraw the receiver as the receiving bank structure in Figure 3.

Having the filterbank representation, we can now obtain the overall transfer matrix. Using the polyphase identity described in Table 1, we observe that the transfer function $T_{k,i}(z)$ from the i -th transmitter input $s_i(n)$ to the k -th signal $y_k(n)$ at the receiver is given by

$$T_{k,i}(z) = [H_k(z)C(z)F_i(z)]_{\downarrow N},$$

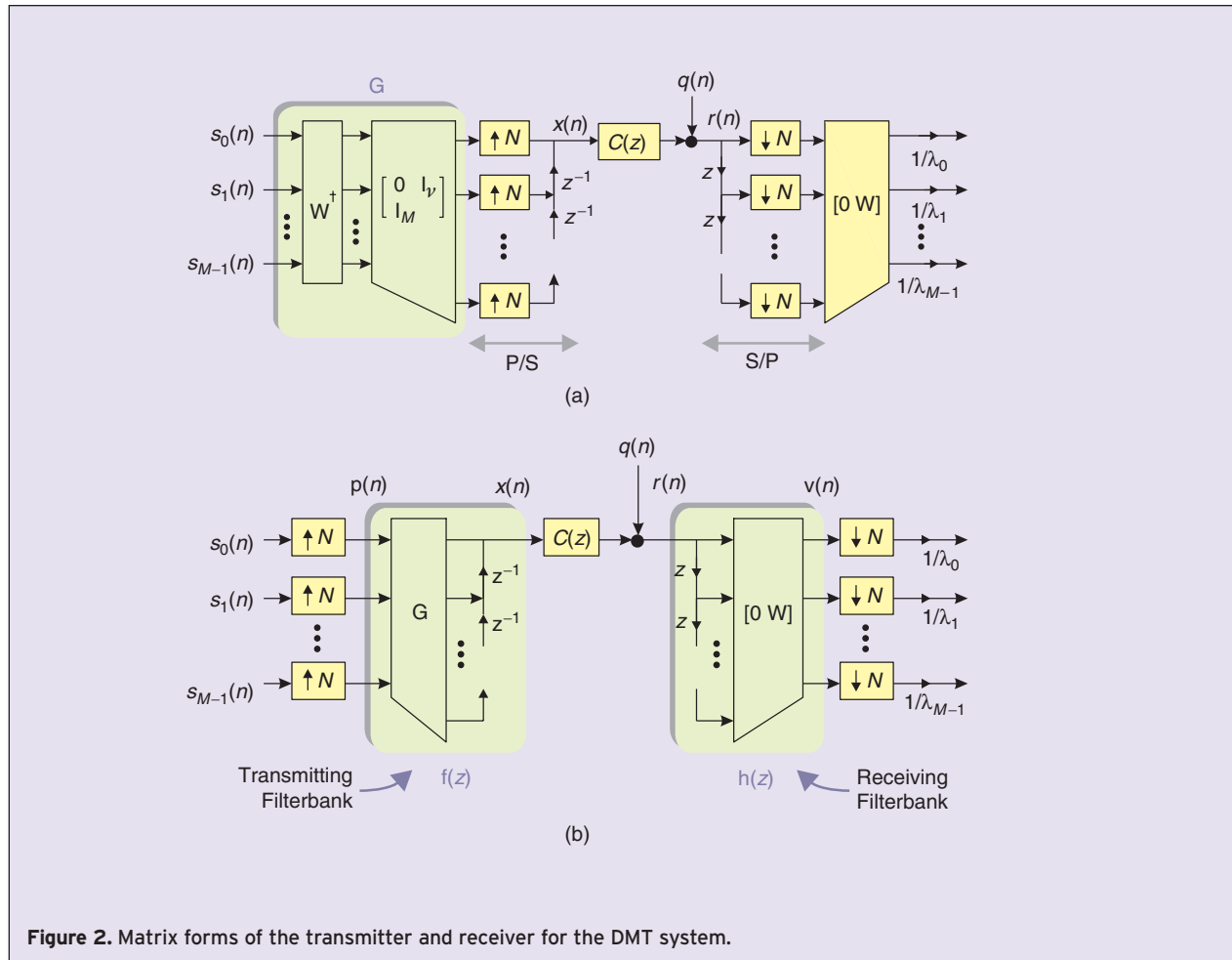

Figure 2. Matrix forms of the transmitter and receiver for the DMT system.

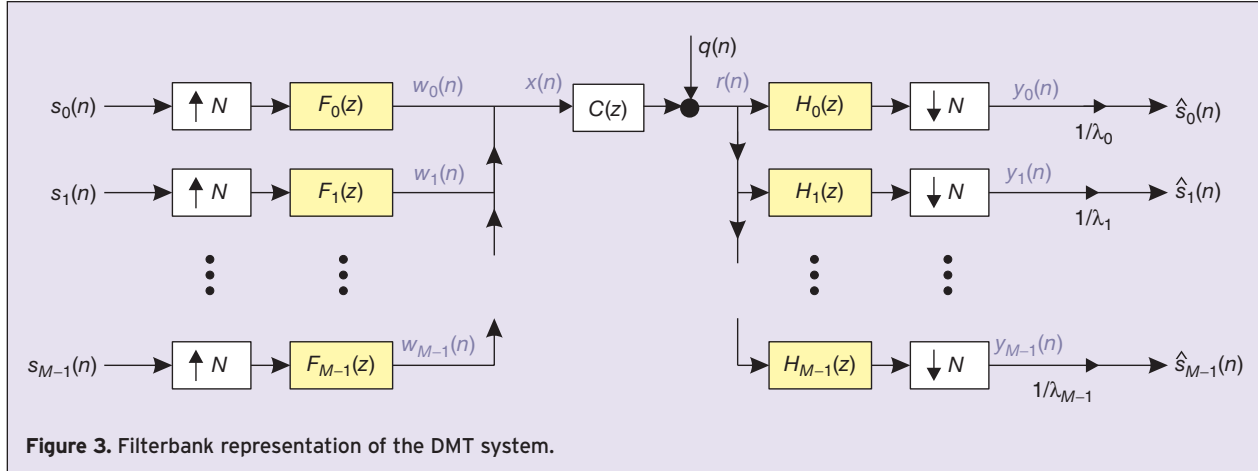

Figure 3. Filterbank representation of the DMT system.

where the notation $[A(z)]_{\downarrow N}$ denotes the N -fold decimated version of $A(z)$ as defined in Table 1. Note that the DMT system is ISI free, meaning that there is zero inter-block and inter-subchannel ISI, and the subchannel gain from the transmitter input $s_k(n)$ to the receiver output $\hat{s}_k(n)$ is one. That is, in the absence of channel noise, $\hat{s}_k(n) = s_k(n)$. The system from $s_i(n)$ to $\hat{s}_k(n)$ is LTI with transfer function $\delta(k - i)$. As $\hat{s}_k(n)$ differs from $y_k(n)$ only in the scalar $1/\lambda_k$, we can conclude that $T_{k,i}(z) = \lambda_k \delta(k - i)$.

Summarizing, we can obtain the following lemma.

Lemma 1 For the system in Figure 3, the transfer function $T_{k,i}(z)$ from the i -th transmitter input $s_i(n)$ to the k -th signal $y_k(n)$ at the receiver is given by

$$T_{k,i}(z) = \lambda_k \delta(k - i), \quad 0 \leq k, i \leq M - 1. \quad (3)$$

The constants λ_k are the M -point DFT of $c(n)$. The result holds for any FIR filter $C(z)$ of order $L \leq \nu$.

So long as the order of $C(z)$ is not larger than ν , the system is free from inter-block interference and inter-subchannel interference. This implies that, if we cascade another filter before or after the channel, as long as the product of this extra filter and $C(z)$ has order no larger than ν the overall system remains ISI free. We will use this observation later to design transmitters and receivers.

From (1) and (2), we see that the transmitting and receiving filters are derived from *rectangular windows*. In particular, the first transmitting filter $F_0(z)$ is a rectangular

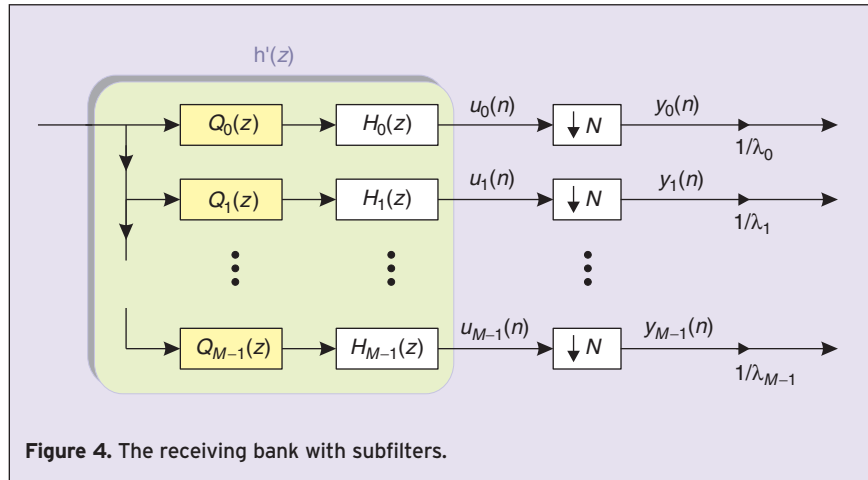

Figure 4. The receiving bank with subfilters.

lar window of length N . All the other transmitting filters are scaled and frequency-shifted versions of the first transmitting filter (*prototype filter*),

$$F_k(z) = W^{vk} F_0(zW^k). \quad (4)$$

Similarly, the first receiving filter is also a rectangular window, but of length M . All the other receiving filters are scaled and frequency-shifted versions of the first receiving filter, $H_k(z) = W^{-vk} H_0(zW^k)$. As the prototype filters are rectangular windows, the frequency selectivity is not good. The first sidelobe has an attenuation of around 13 dB only and the stopband decays slowly at a rate inversely proportional to the frequency. Poor frequency selectivity leads to bad frequency separation. This results in spectral leakage in the transmitted spectrum and poor RFI suppression at the receiver side.

Receivers with Subfilters

To improve the frequency selectivity of the receiving filters, we introduce additional FIR $Q_k(z)$ to the receiving bank, as

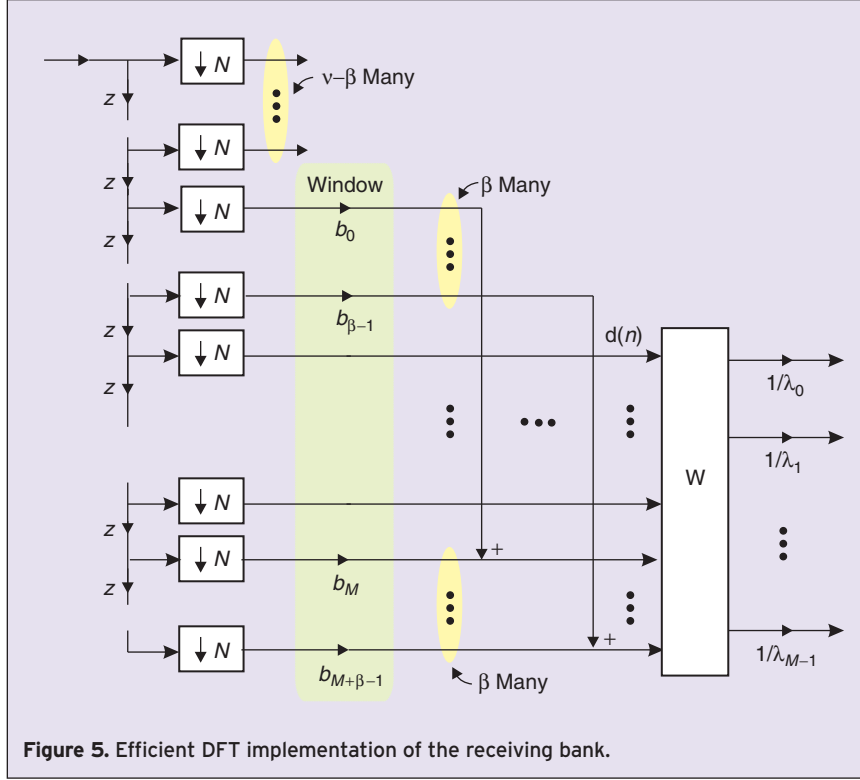

shown in Figure 4. These additional filters will be called *subfilters* as their order α is generally much smaller than M . With the subfilters, the k -th effective receiving filter becomes $H'_k(z) = H_k(z)Q_k(z)$ and the frequency responses of the receiving filters are further shaped by the subfilters. The transfer function from the i -th transmitter input $s_i(n)$ to the k -th signal $y_k(n)$ at the receiver in Figure 3 becomes $T_{k,i}(z) = [H_k(z)(Q_k(z)C(z))F_i(z)]_{\downarrow N}$; it is the same expression except that the channel is replaced by the composite channel $Q_k(z)C(z)$. From Lemma 1, we know that the system is free from ISI as long as the order of the composite channel is not larger than ν . In particular, $T_{k,i}(z)$ is the same as in (3) except that the coefficients λ_k are now the M -point DFT of the composite channel.

We can choose the subfilters so that λ_k remain the same after the subfilters are included. To have this property, we need $Q_k(e^{j2\pi k/M}) = 1$, i.e., the k -th DFT coefficient of $Q_k(z)$ normalized to one. In the special case that the subfilters are chosen as shifted versions of the first subfilter, $Q_k(z) = Q_0(zW^k)$, then $Q_k(e^{j2\pi k/M})$ is equal to $Q_0(e^{j0})$. That is, we only need the DC value of the first subfilter to be one. This translates to the time-domain condition that the sum of the coefficients is one. Suppose that $Q_0(z)$ is a causal FIR filter of order β , then the condition is

$$\sum_{n=0}^{\beta} q_0(n) = 1. \quad (5)$$

This condition can be easily satisfied by a simple normalization after $q_0(n)$ is designed without constraint. The normalization in (5) will be assumed in the following discussions. Furthermore when the other subfilters are shifted versions of the first subfilter, the new receiving filter becomes $H'_k(z) = W^{-\nu k}H'_0(zW^k)$. They are also shifted versions of the new prototype filter $H'_0(z)$ except for some scalars. We will see below that these receiving filters form a DFT bank and can be implemented efficiently. The complexity is almost the same as the conventional DMT system without subfilters.

Implementation of Receiving Bank with Subfilters

The new prototype filter is the product of $Q_0(z)$ and the rectangular window $H_0(z)$ given in (2). Let the coefficients of $H'_0(z)$ be b_i/\sqrt{M} and we write it as $H'_0(z) = \frac{z^{\nu-\beta}}{\sqrt{M}} \sum_{i=0}^{M+\beta-1} b_i z^i$. We will call b_i *receiver window coefficients* for reasons that will become clear later. Using the relation $H'_k(z) = W^{-\nu k}H'_0(zW^k)$, we can write the new k -th receiving filter as

$$\begin{aligned} H'_k(z) &= \frac{z^{\nu-\beta}}{\sqrt{M}} \sum_{i=0}^{M+\beta-1} b_i W^{k(i-\beta)} z^i \\ &= \frac{z^{\nu-\beta}}{\sqrt{M}} (1 \quad W^k \quad \dots \quad W^{k(M-1)}) \mathbf{g}(z), \end{aligned}$$

where

$$\mathbf{g}(z) = \begin{pmatrix} \mathbf{0} & \mathbf{I}_M \end{pmatrix} \text{diag}(b_0 b_1 \dots b_{M+\beta-1}) \begin{pmatrix} 1 \\ z \\ \vdots \\ z^{M+\beta-1} \end{pmatrix}.$$

Then the new receiving bank $\mathbf{h}'(z)$ as indicated in Figure 4 can be written as $\mathbf{h}'(z) = z^{\nu-\beta} \mathbf{W} \mathbf{g}(z)$. This expression gives rise to the implementation of the receiver in Figure 5, where we have moved the decimators to the left by using the Noble identity for decimators in Table 1. Note that the first $\nu - \beta$ samples are discarded due to the advance $z^{\nu-\beta}$.

Better separation among the transmitting filters translates to less spectral leakage in the transmitted spectrum while better separation among the receiving filters leads to improved RFI suppression.

Window Coefficients b_k

The new prototype filter $H'_0(z)$ is the convolution of $h_0(n)$ and a much shorter $q_0(n)$. As $h_0(z)$ is a rectangular window, each coefficient b_k is a partial sum of the coefficients of $q_0(n)$. With the normalization in (5), most of the window coefficients are equal to one, except for those on the two ends.

The middle $M - \beta$ coefficients are equal to one, and the remaining coefficients, β coefficients on each side, have non-unity values. Figure 6(a) gives an example of window coefficients. Furthermore, we can verify that the time shifts of b_k add up to one, in particular,

$$\sum_{\ell=-\infty}^{\infty} b_{k-\ell M} = 1. \quad (6)$$

This is known as the time-domain Nyquist property [19], [20]. The subfilter viewpoint allows the time-domain Nyquist property to be satisfied inherently in the receiver design.

Connection with the Usual Receiver Windowing

If we observe the implementation in Figure 5, we see that the samples are first multiplied by b_k (i.e., *windowed* by b_k). The matrix $\begin{pmatrix} 0 & \\ \mathbf{I}_\beta & \mathbf{I}_M \end{pmatrix}$ performs the operation of *folding* the first β samples and add to the last β samples as shown in Figure 6(b). Then the resulting last M samples are passed over for DFT computation, followed by FEQ. This is the same as the usual receiver windowing described in [21].

Transmitters with Subfilters

Similar to the case of the receiving end, we can also introduce subfilters to the transmitter side to improve the frequency selectivity of the transmitting filters. Figure 7 shows the transmitting bank with subfilters. Suppose the subfilters are FIR filters $P_k(z)$ with order α . The k -th new transmitting filter is $F'_k(z) = F_k(z)P_k(z)$. The new transmitting filters are of length $N + \alpha$, as $F_k(z)$ are of length N . Now the transfer function from the i -th transmitter input $s_i(n)$ to the k -th signal $y_k(n)$ at the receiver (Figure 3(b)) becomes $T_{k,i}(z) = [H_k(z)(P_i(z)C(z))F_i(z)]_{\downarrow N}$. We can also apply the result in Lemma 1 here. The overall system remains ISI free if the order of the subfilters α sat-

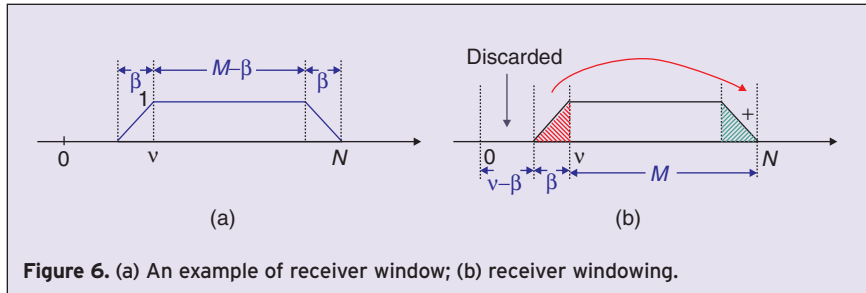

Figure 6. (a) An example of receiver window; (b) receiver windowing.

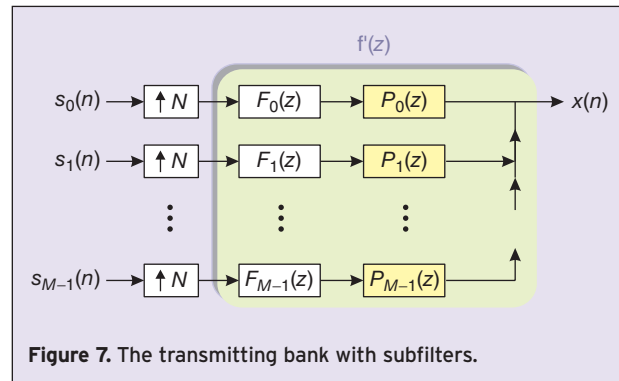

Figure 7. The transmitting bank with subfilters.

isfies $\alpha + L \leq v$. The transfer function $T_{k,i}(z)$ is the same as in (3), except that now the coefficients λ_k are the M -point DFT of $p_k(n) * c(n)$. As in the receiver case, we can choose the subfilters to be shifted versions of the first subfilter, i.e., $P_k(z) = P_0(zW^k)$. In this case we can have λ_k remain the same after subfilters are included by normalizing the DC value of $P_0(z)$ like that in (5). (Without loss of generality, such a normalization will be assumed in the following discussion.) Furthermore, as we will derive next, the resulting transmitting filters form a DFT bank, which can be implemented very efficiently.

Implementation of the Transmitting Bank with Subfilters

When the subfilters are frequency shifted versions of the first subfilter, the new transmitting filters are also frequency shifted versions of the new prototype except for some scalars. In particular, $F'_k(z) = W^{vk}F'_0(zW^k)$. Let the coefficients of the prototype be a_i/\sqrt{M} and $F'_0(z) = \frac{1}{\sqrt{M}} \sum_{i=0}^{N+\alpha-1} a_i z^{-i}$. Like the case of receiver windowing, we call these a_i window coefficients. As there is a frequency shifting relation among the transmitting filters, given the coefficients of the prototype, we can obtain the coefficients of all

The filterbank representation allows us to express the power spectrum of the transmitted signal $x(n)$ in terms of the transmitting filters and thus in terms of the subfilters to be optimized.

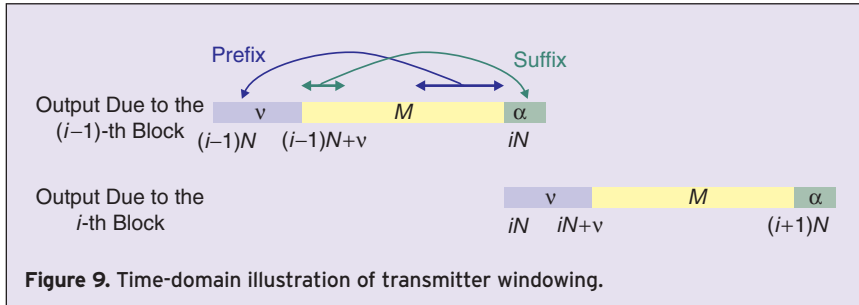
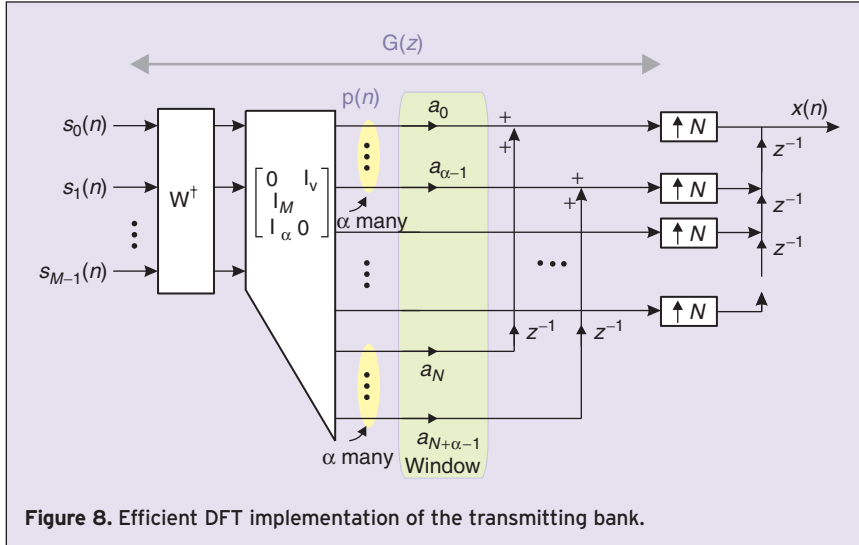

the other transmitting filters. The new transmitting bank $\mathbf{f}'(z) = (F'_0(z) \ F'_1(z) \ \cdots \ F'_{M-1}(z))$ as indicated in Figure 7 can be expressed as

$$\mathbf{f}'(z) = (1 \ z^{-1} \ \cdots \ z^{-N+1}) \mathbf{G}(z^N), \quad \text{where}$$

$$\mathbf{G}(z) = \begin{pmatrix} \mathbf{D}_0 & \mathbf{D}_1 z^{-1} \\ \mathbf{0} & \mathbf{0} \end{pmatrix} \begin{pmatrix} \mathbf{0} & \mathbf{I}_v \\ \mathbf{I}_M & \mathbf{0} \\ \mathbf{I}_\alpha & \mathbf{0} \end{pmatrix} \mathbf{W}^T. \quad (7)$$

The matrices \mathbf{D}_0 and \mathbf{D}_1 are diagonal matrices, respectively, $\text{diag}(a_0 \ a_1 \ \cdots \ a_{N-1})$, and $\text{diag}(a_N \ a_{N+1} \ \cdots \ a_{N+\alpha-1})$.

Such an expression gives rise to the implementation in Figure 8, where we have used the Noble identity for exchanging LTI filters and expanders in Table 1 to move $\mathbf{G}(z^N)$ to the left of the expanders. The coefficients a_i come from the convolution of an N -point rec-

tangular window with a much shorter $p_0(n)$ of length α . When the sum of the coefficients of $p_0(n)$ is normalized to one, most of the coefficients a_i are equal to one. The middle $N - \alpha$ coefficients are equal to one. Only the remaining 2α coefficients, α on each end, can have non-unity values and only for these coefficients multiplications are needed.

Connection with the Usual Transmitter Windowing

Observing the DFT bank implementation in Figure 8, we see that for each input block, M -point IDFT is performed, followed by the insertion of cyclic prefix of length v and also the insertion of suffix of length α . The resulting vector $\mathbf{p}(n)$, as shown in Figure 8, is of size $N + \alpha$. The window coefficients are applied to each vector. Then the last α samples of the previous block are added to the first α samples of the current block,

as shown in Figure 9. This is the same as the usual transmitter windowing [2].

Transmitted Power Spectrum

The filterbank representation allows us to express the power spectrum of the transmitted signal $x(n)$ in terms of the transmitting filters and thus in terms of the subfilters to be optimized. No assumption will be made on the length of the transmitting filters and the result is also applicable to the cases with subfilters.

For OFDM systems in wireless applications, the inputs $s_k(n)$ can be assumed to be uncorrelated and the transmitted power spectrum has been derived in [12]. The assumption of uncorrelated input symbols is not valid for DMT systems in wired applications. This is because the DMT system uses baseband transmission and the signal to be transmitted is real. This requires that the inputs of the IDFT matrix have the conjugate symmetric property,

$s_k(n) = s_{M-k}^*(n)$, $k = 1, 2, \dots, M-1$, and $s_0(n)$ is real. For even M , usually the case in practice, $s_{M/2}(n)$ is also real. This conjugate symmetric property means that the symbols assigned to the second half and the first half of the subchannels are strongly correlated and thus we can no longer assume that the inputs are uncorrelated.

For those inputs $s_k(n)$ that are in conjugate pairs, let the real part be $s_k^{(r)}(n)$ and the imaginary part be $s_k^{(i)}(n)$. We can treat these real parts and imaginary parts as random processes and assume, reasonably, that these random processes are white, uncorrelated, jointly wide-sense stationary with zero mean and variance $\mathcal{E}_{s,k}/2$. (The scalar 1/2 is included so that the variance of $s_k(n)$ is $\mathcal{E}_{s,k}$.) For the k -th and $(M-k)$ -th subchannels, the inputs are a complex conjugate pair. When the transmitting filters are shifted versions of the prototype filter as in (4) and the prototype has real coefficients, the coefficients of the transmitting filters are also in conjugate pairs, $f_{M-k}(n) = f_k^*(n)$. As the result, the outputs of each pair are also the conjugates of each other. Now instead of considering the output of an individual subchannel, let us consider the sum of the outputs of each pair. Let the output of the k -th transmitting filter be $w_k(n)$ as indicated in Figure 3 and define $w_k'(n) = w_k(n) + w_{M-k}(n)$. Then $w_k'(n)$ can be written as

$$w_k'(n) = 2 \sum_{\ell} \left(s_k^{(r)}(\ell) f_k^{(r)}(n - N\ell) - s_k^{(i)}(\ell) f_k^{(i)}(n - N\ell) \right),$$

where $f_k^{(r)}(n)$ and $f_k^{(i)}(n)$ are, respectively, the real and imaginary part of $f_k(n)$. As the real and imaginary parts of the transmitter inputs are uncorrelated, the power spectrum of $w_k'(n)$ is

$$S_{w_k'}(e^{j\omega}) = \frac{2\mathcal{E}_{s,k}}{N} \left(|F_k^{(r)}(e^{j\omega})|^2 + |F_k^{(i)}(e^{j\omega})|^2 \right),$$

where $F_k^{(r)}(e^{j\omega})$ and $F_k^{(i)}(e^{j\omega})$ are respectively the Fourier transforms of $f_k^{(r)}(n)$ and $f_k^{(i)}(n)$. It turns out that

$$2 \left(|F_k^{(r)}(e^{j\omega})|^2 + |F_k^{(i)}(e^{j\omega})|^2 \right) = |F_k(e^{j\omega})|^2 + |F_{M-k}(e^{j\omega})|^2.$$

We can obtain the transmitted power spectrum by summing up the contributions from $w_k'(n)$, plus $w_0(n)$ and $w_{M/2}(n)$ (if M is even). We arrive at the following simple expression for the transmitted spectrum

$$S_x(e^{j\omega}) = \frac{1}{N} \sum_{k=0}^{M-1} \mathcal{E}_{s,k} |F_k(e^{j\omega})|^2. \quad (8)$$

We can further observe that if an equal power allocation is used, the inputs of all the subchannels have the same vari-

ance \mathcal{E}_s and the transmitted power spectrum becomes the same as that of the OFDM system derived in [12].

Now let us consider the transmitted spectrum when there are subfilters. Assume that the other subfilters are frequency shifted versions of the first subfilter. When the first subfilter has real coefficients, the coefficients of the k -th and $(M-k)$ -th new transmitting filters also form a conjugate pair. The above derivation can also be carried out for the case with subfilters. The transmitted power spectrum can be easily obtained by replacing the transmitting filters in (8) by $F_k'(e^{j\omega})$.

Design of Receiver Subfilters

The frequency selectivity of the receiving filters are important for RFI suppression. The radio interference is known to be of a narrowband nature. For the duration of one DMT symbol, it can be considered as a sum of sinusoids. To analyze the effect of interference, we can apply an interference-only signal $v(n)$ to the receiver in Figure 4. Suppose that there are J interference sources, and the interference is modelled as $v(n) = \sum_{\ell=0}^{J-1} \mu_{\ell} \cos(\omega_{\ell}n + \theta_{\ell})$. The interference term at the output of the k -th receiving filter $H_k'(z)$ is

$$u_k(n) = \frac{1}{2} \sum_{\ell=0}^{J-1} \mu_{\ell} [H_k'(e^{j\omega_{\ell}}) e^{j(\omega_{\ell}n + \theta_{\ell})} + H_k'(e^{-j\omega_{\ell}}) e^{-j(\omega_{\ell}n + \theta_{\ell})}].$$

Minimization of interference terms requires the knowledge of μ_{ℓ} , ω_{ℓ} and θ_{ℓ} .

First let us consider the case when the information of the interference is not available. In this case, we can alleviate the effect of interference in the k -th subchannel by minimizing the stopband of the receiving filters. When the receiving filters are frequency shifted versions of the prototype, we only need to consider the stopband energy of the prototype,

$$\phi_h = \int_{\omega \in O_h} |H_0'(e^{j\omega})|^2 d\omega, \quad (9)$$

where O_h denotes the stopband of the prototype filter. Note that $H_0'(z)$ is the product of $Q_0(z)$ and $H_0(z)$. We can write its Fourier transform as $H_0'(e^{j\omega}) = H_0(e^{j\omega}) \tau_{\beta}(\omega) \mathbf{q}_0$, where $\tau_{\beta}(\omega)$ is the $1 \times \beta$ row vector $(1 \ e^{-j\omega} \ \dots \ e^{-j\beta\omega})$ and \mathbf{q}_0 is the column vector $(q_0(0) \ q_0(1) \ \dots \ q_0(\beta))^T$. The stopband energy is

$$\phi_h = \mathbf{q}_0^{\dagger} \mathbf{B} \mathbf{q}_0, \quad \text{where} \\ \mathbf{B} = \int_{\omega \in O_h} |H_0(e^{j\omega})|^2 \tau_{\beta}^{\dagger}(\omega) \tau_{\beta}(\omega) d\omega. \quad (10)$$

To avoid a trivial solution, we can fix the energy of the

first subfilter to be one, $\mathbf{q}_0^\dagger \mathbf{q}_0 = 1$. The matrix \mathbf{B} is positive definite because the objective function represents the stopband energy of the prototype filter, which is always positive. To minimize ϕ_h , we can choose \mathbf{q}_0 as the eigenvector associated with the smallest eigenvalue of \mathbf{B} . Such an approach does not depend on the RFI statistics or the channel; it has the advantage that the subfilters need to be designed only once. The subfilters need not be redesigned when the interference changes.

If the information of the interference sources is available to the receiver, the subfilters can be individually optimized. The amplitude of the k -th interference signal $u_k(n)$ is a nonlinear function of the k -th subfilter coefficients. To simplify the problem, note that the interference due to the ℓ -th source will be small if $\mu_\ell^2 (|H'_k(e^{j\omega_\ell})|^2 + |H'_k(e^{-j\omega_\ell})|^2)$ is small. The k -th subchannel interference can be mitigated

by designing $Q_k(z)$ to minimize $\phi_{k,h}$,

$$\phi_{k,h} = \sum_{\ell=0}^{J-1} \mu_\ell^2 (|H'_k(e^{j\omega_\ell})|^2 + |H'_k(e^{-j\omega_\ell})|^2). \quad (11)$$

We can write $\phi_{k,h}$ in a quadratic form similar to that in (10) and find the optimal subfilters. Such an optimization requires only the amplitudes and frequencies, but not the phases, of the interference sources. When the subfilters are so designed, the receiving bank does not have the DFT bank structure in Figure 5. Nonetheless, the receiver can be implemented with a much reduced complexity using the sliding window approach in [26]. When the subfilters $Q_k(z)$ are shifted versions of $Q_0(z)$, we can design $Q_0(z)$ to minimize the total interference $\sum_k \phi_{k,h}$ [27].

Example 1.

Receiver Subfiltering

In this example, we design the subfilters for RFI reduction at the receiver. The DFT size is $M = 512$ and cyclic prefix length is $\nu = 40$. The order of the subfilters is $\beta = 10$. The channel used in this example is VDSL loop#1 (4500 ft) [2] and the channel noise is AWGN of -140 dBm. Model 1 differential mode RFI interference is considered [2]. Four RFI sources are assumed in the simulations, at respectively 660, 710, 770 and 1050 KHz, of strength -60 , -40 , -70 , and -55 dBm, respectively.

We will consider two different subfilter designs. In the first design, the subfilters $Q_k(z)$ are shifted versions of $Q_0(z)$ and only $Q_0(z)$ needs to be designed. The subfilter $Q_0(z)$ is the solution to the minimization problem in (10). In this case the receiving filters form a DFT bank and can be implemented as in Figure 5. In the second design, the RFI source is known to the receiver and the subfilters $Q_k(z)$ are individually optimized by minimizing the objective function $\phi_{k,h}$ in (11). The SINRs (signal-to-noise-interference ratio) of the subchannels are as shown in Figure 10. The first case is labelled ‘subfilter (DFT bank)’ while the second case ‘subfilter (RFI known)’. For comparison, we have also shown the subchannel SINRs for the cases of rectangular, Hanning windows, and also the window from [23]. The receivers with subfilters enjoy higher SINRs for the tones that are close to the RFI frequencies, especially when the statistics of the RFI source is known and the subfilters are optimized individually. As a result, higher transmission rates can be achieved. The transmission rate of the first case is 7.44 Mb/s, and that of the second case is 8.54 Mb/s. The transmission rates for the cases of rectangular, Hanning windows, and [23] are 6.84, 7.16, and 7.27 Mb/s, respectively.

Design of Transmitter Subfilters

For the transmitter side, let us first consider the case when the transmitting filters are constrained to be shift-

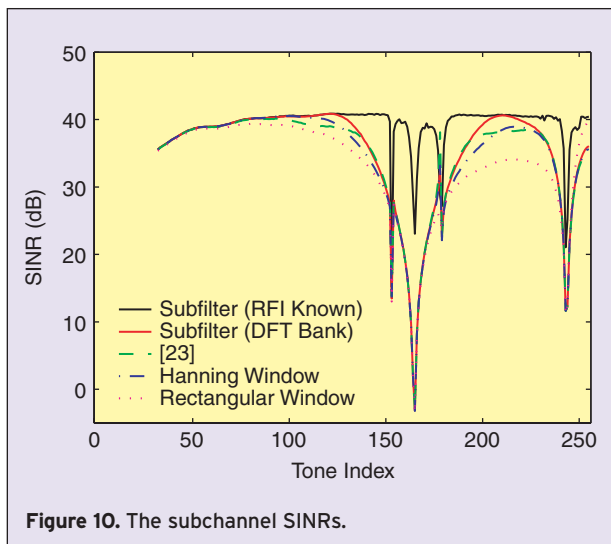

Figure 10. The subchannel SINRs.

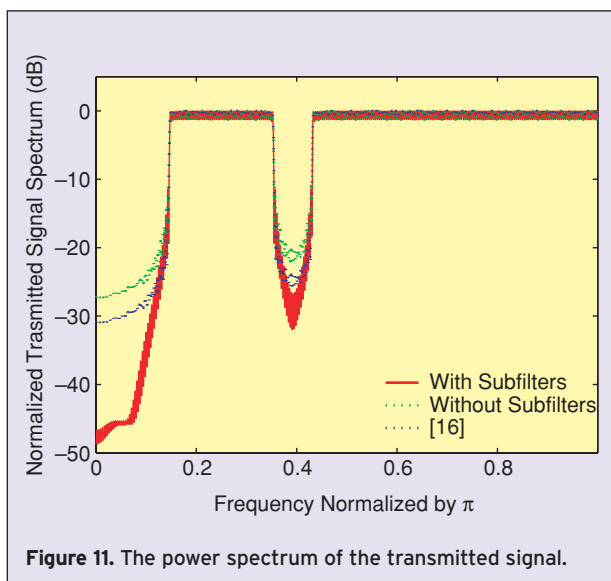

Figure 11. The power spectrum of the transmitted signal.

ed versions of one prototype. From the expression in (8), we see that spectral leakage can be minimized by minimizing the stopband energy of the prototype filter $F'_0(z)$. Following a procedure similar to the design of receiver subfilters, we can write the stopband energy ϕ_f of the prototype $F'_0(z)$ as

$$\phi_f = \mathbf{p}_0^\dagger \mathbf{A} \mathbf{p}_0, \quad \text{where} \quad \mathbf{A} = \int_{\omega \in \mathcal{O}_f} |F'_0(e^{j\omega})|^2 \tau_\alpha^\dagger(\omega) \tau_\alpha(\omega) d\omega. \quad (12)$$

We can see that ϕ_f can be minimized by choosing \mathbf{p}_0 to be the eigenvector associated with the minimum eigenvalue of \mathbf{A} .

Now consider the case when the subfilters are not constrained. The total spectral leakage is

$$\int_{\omega \in \mathcal{O}_u} S_x(e^{j\omega}) d\omega, \quad (13)$$

where \mathcal{O}_u denotes the band in which leakage is undesired. The total leakage can be minimized if we can minimize the individual contribution $\phi_{k,f}$ from each subchannel,

$$\phi_{k,f} = \int_{\omega \in \mathcal{O}_u} |F'_k(e^{j\omega})|^2 d\omega.$$

We can write $\phi_{k,f}$ in a quadratic form like that in (12) and find the optimal subfilters. In this case the subfilters do not form a DFT bank, and neither do the new transmitting filters. An efficient implementation of the resulting transmitting bank can be found in [18].

Example 2. Transmitter Subfiltering

The block size $M = 512$ and prefix length $\nu = 40$. The subfilters are shifted versions of the first subfilter and thus the transmitting filters form a DFT bank. The order α of the subfilters is 20. We form the positive definite matrix \mathbf{A} and compute the eigenvector corresponding to the smallest eigenvalue to obtain \mathbf{p}_0 . Figure 11 shows the spectrum of the transmitter output. The subcarriers used are 38 to 90 and 111 to 255. The subcarriers with indices smaller than 38 are reserved for voice band and upstream transmission, and those with indices between 91 and 110 are for egress (interference of DMT signals to wireless radio frequency transmission) control. Also shown in the figure is the output spectrum when the transmitter window of [16] is used, which requires no extra cyclic prefix but additional post-processing is needed at the receiver. We see that the spectrum with the subfilters has a much smaller spectral leakage in unused bands.

Implementation and Complexity

For the conventional DMT system in Figure 1, the main computations of the transceiver are those of the IDFT

and DFT matrices, for which fast algorithms can be applied. The complexity of the transmitter is simply that of an IDFT matrix and the complexity of the receiver is that of a DFT matrix plus M multiplications for FEQs. Moreover, except for the FEQs, the computations are channel independent. For a system with receiver subfilters, we can observe the implementation complexity from Figure 5. Compared with the conventional case, the new receiver needs only 2β more multiplications (due to the non-unity window coefficients) and β more additions for every block of outputs. Similarly, the complexity of the transmitter with subfilters in Figure 8 requires 2α more multiplications and α more additions per output block. As α and β are usually much smaller than M , in either case the overhead of subfiltering is very small.

Conclusions

In this work, we have presented a filterbank approach to the design of transmitter/receiver by introducing subfilters. The frequency separation among the subchannels can be considerably improved. Better separation among the transmitting filters translates to less spectral leakage in the transmitted spectrum while better separation among the receiving filters leads to improved RFI suppression. As these are frequency based characteristics, the filterbank transceiver representation provides a natural and useful framework for formulating the problem. The transmitter/receiver designs are converted to simple eigen-problems and closed form solutions can be obtained.

References

- [1] "Asymmetric Digital Subscriber Lines (ADSL)-Metallic Interface," ANSI T1.413, 1998.
- [2] "Very-high Speed Digital Subscriber Lines (VDSL)-Metallic Interface," ANSI T1.424, 2002.
- [3] ISO/IEC, IEEE Std. 802.11a, 1999.
- [4] ETSI, "Digital Video Broadcasting; Framing, Structure, Channel Coding and Modulation for Digital Terrestrial Television (DVB-T)," ETS 300 744, 1997.
- [5] L. De Clercq, M. Peeters, S. Schelstraete, and T. Pollet, "Mitigation of Radio Interference in xDSL Transmission," *IEEE Communications Magazine*, vol. 38, no. 3, Mar. 2000.
- [6] A. Vahlin and N. Holte, "Optimal Finite Duration Pulses for OFDM," *IEEE Trans. Communications*, vol. 44, no. 1, pp. 10–14, Jan. 1996.
- [7] H. Nikoogar and R. Prasad, "Optimal Waveform Design for Multicarrier Transmission through a Multipath Channel," in *Proc. IEEE Vehicular Tech. Conf.*, vol. 3, May 1997, pp. 1812–1816.
- [8] K. Mathews and K.-D. Kammeyer, "Optimal Design of a Multicarrier Systems with Soft Impulse Shaping Including Equalization in Time or Frequency Direction," in *Proc. IEEE Global Telecommunications Conference*, vol. 1, Nov. 1997, pp. 310–314.
- [9] N. Laurenti and L. Vangelista, "Filter Design for the Conjugate OFDM-OQAM System," presented at *First Int'l Workshop on Image and Signal Processing and Analysis*, June 2000.
- [10] S.B. Slimane, "Performance of OFDM Systems with Time-Limited Waveforms over Multipath Radio Channels," presented at *Global Telecommunications Conference*, 1998.
- [11] M. Pauli and P. Kuchenbecker, "On the Reduction of the Out-of-Band

Radiation of OFDM-Signals," in *Proc. IEEE International Conference on Communications*, vol. 3, June 1998, pp. 1304–1308.

[12] Y.-P. Lin and S.-M. Phoong, "OFDM Transmitters: Analog Representation and DFT Based Implementation," *IEEE Trans. Signal Processing*, Sept. 2003.

[13] R.W. Lowdermilk, "Design and Performance of Fading Insensitive Orthogonal Frequency Division Multiplexing (OFDM) using Polyphase Filtering Techniques," in *Conference Record of the Thirtieth Asilomar Conference on Signals, Systems and Computers*, Nov. 1996.

[14] H. Boelcskei, P. Duhamel, and R. Hleiss, "Design of Pulse Shaping OFDM/OQAM Systems for High Data-Rate Transmission over Wireless Channels," in *Proc. IEEE International Conference on Communications*, 1999.

[15] P. Siohan, C. Siclet, and N. Lacaille, "Analysis and Design of OFDM/OQAM Systems based on Filterbank Theory," *IEEE Trans. Signal Processing*, May 2002.

[16] G. Cuyppers, K. Vanbleu, G. Ysebaert, M. Moonen, "Egress Reduction By Intra-symbol Windowing in DMT-based Transmissions," in *Proc. IEEE International Conference on Acoustics, Speech and Signal Processing*, 2003.

[17] Y.-P. Lin and S.-M. Phoong, "Window Designs for DFT based Multi-carrier Systems," *IEEE Trans. Signal Processing*, Mar. 2005.

[18] C.-Y. Chen, and S.-M. Phoong, "Per tone Shaping filters for DMT Transmitters," in *Proc. IEEE Int. Conf. Acoustic, Speech, and Signal Processing*, May 2004.

[19] C. Muschallik, "Improving an OFDM Reception Using an Adaptive Nyquist Windowing," *IEEE Trans. Consumer Electronics*, vol. 42, no. 3, pp. 259–269, Aug. 1996.

[20] S.H. Müller-Weinfurter, "Optimal Nyquist Windowing in OFDM Receivers," *IEEE Trans. Communications*, vol. 49, no. 3, Mar. 2001.

[21] P. Spruyt, P. Reusens and S. Braet, "Performance of Improved DMT Transceiver for VDSL," ANSI T1E1.4, Doc. 96-104, Apr. 1996.

[22] S. Kapoor and S. Nedic, "Interference Suppression in DMT Receivers Using Windowing," in *Proc. IEEE International Conference on Communications*, 2000.

[23] A.J. Redfern, "Receiver Window Design for Multicarrier Communication Systems," *IEEE Journal on Selected Areas in Communications*, vol. 20, no. 5, pp. 1029–1036, Jun. 2002.

[24] G. Ysebaert, K. Vanbleu, G. Cuyppers, and M. Moonen, "Joint Window and Time Domain Equalizer Design for Bit Rate Maximization in DMT-Receivers," *IEEE Journal on Selected Areas in Communications*, vol. 20, no. 5, pp. 1029–1036, Jun. 2002.

[25] P.P. Vaidyanathan, *Multirate Systems and Filter Banks*, Englewood Cliffs, Prentice-Hall, 1993.

[26] K. Van Acker, G. Leus, M. Moonen, O. van de Wiel, and T. Pollet, "Per Tone Equalization for DMT-Based Systems," *IEEE Trans. Communications*, vol. 49, no. 1, Jan. 2001.

[27] C.-C. Li and Y.-P. Lin, "Receiver Window Designs for Radio Frequency Interference Suppression," presented at *European Signal Processing Conference*, 2006.



Yuan-Pei Lin (S'93-M'97-SM'03) was born in Taipei, Taiwan, 1970. She received the B.S. degree in control engineering from the National Chiao-Tung University, Taiwan, in 1992, and the M.S. degree and the Ph.D. degree, both in electrical engineering from California Institute of Technology, in 1993 and 1997, respectively. She joined the Department of Electrical and Control Engineering of National Chiao-Tung University, Taiwan, in 1997. Her research interests include digital signal processing, multirate filter banks, and signal processing for digital communication, particularly the area of multicarrier transmission.

She is a recipient of 2004 Ta-You Wu Memorial Award. She served as an associate editor for *IEEE Transaction on Signal Processing* 2002–2006. She is currently an associate editor for *IEEE Signal Processing Letters*, *IEEE Transaction on Circuits and Systems II*, *EURASIP Journal on Applied Signal Processing*, and *Multidimensional Systems and Signal Processing*, Academic Press. She is also a Distinguished Lecturer of the *IEEE Circuits and Systems Society* for 2006–2007.



Chien-Chang Li was born in Penghu, Taiwan, R.O.C., in 1980. He received the B.S. degree in power mechanical engineering from the National Tsing-Hua University, Hsinchu, Taiwan in 2003. He is now pursuing the Ph.D. degree in the Dept. of Electrical and Control Engineering, National Chiao-Tung University, Taiwan. His research interests include digital signal processing, multirate systems and digital communication systems



See-May Phoong (M'96-SM'04) was born in Johor, Malaysia, in 1968. He received the B.S. degree in electrical engineering from the National Taiwan University (NTU), Taipei, Taiwan, R.O.C., in 1991 and M.S. and Ph.D. degrees in electrical engineering from the California Institute of Technology (Caltech), Pasadena, California, in 1992 and 1996, respectively.

He was with the Faculty of Electronic and Electrical Engineering, Nanyang Technological University, Singapore, from September 1996 to September 1997. In September 1997, he joined the Graduate Institute of Communication Engineering and the Department of Electrical Engineering, NTU, as an Assistant Professor, and since August 2006, he has been a Professor.

Dr. Phoong is currently an Associate Editor for the *IEEE Transactions on Circuits and Systems I*. He has previously served as an Associate Editor for *Transactions on Circuits and Systems II: Analog and Digital Signal Processing* (Jan. 2002–Dec. 2003) and *IEEE Signal Processing Letters* (March 2002–Feb. 2005). His interests include multirate signal processing, filter banks and their application to communications. He received the Charles H. Wilts Prize (1997) for outstanding independent research in electrical engineering at Caltech. He was also a recipient of the Chinese Institute of Electrical Engineering's Outstanding Youth Electrical Engineer Award (2005).