Abstract

The Personal Access Communications System (PACS) is an American National Standards Institute common air interface standard developed for the 1.9 GHz PCS band in the United States. PACS uses frequency division duplexing technology and is optimized to support low-mobility pedestrian outdoor usage and wireless local loop applications in a medium-range environment. PACS-Unlicensed B (PACS-UB) is a version of PACS using time division duplexing. PACS-UB has been optimized for private, indoor wireless PBX applications and cordless telephony. Both modes of operation are supported using the same portable hardware and the same signaling protocol.

PACS: Personal Access Communications System – A Tutorial

ANTHONY R. NOERPEL, YI-BING LIN, AND HOWARD SHERRY

The Federal Communications Commission (FCC) Memorandum Opinion and Order [1] on the emerging technologies frequency band allocates two blocks of spectrum — 1850 to 1910 and 1930 to 1990 MHz — in three paired 15 MHz segments and three paired 5 MHz segments for use as broadband licensed personal communications services (PCS). The paired nature of this frequency allocation supports frequency-division duplex (FDD) operation. The Memorandum Opinion and Order further specifies that 10 MHz of spectrum, from 1920 to 1930 MHz, be set aside for unlicensed isochronous operation. Duplex communications in a single frequency band such as this requires time-division-duplex (TDD) operation. A requirement for a system operating in this band is its compliance to new FCC Rules in Part 15, Subpart D. These rules define an “etiquette” by which unlike systems can make common use of the allocated spectrum. The etiquette rules have two principal goals:

- To enable unlicensed PCS systems to be deployed in a coordinated fashion with existing fixed microwave systems (until the spectrum is cleared)
- To enable unlike systems operating in this band to share the allocated spectrum reasonably

The FCC has gone on record as encouraging technologies which would interoperate in both the licensed and unlicensed spectrum so as to give future PCS customers the opportunity for economic, high-quality, and flexible communications. Notably, Julius Knapp of the FCC in an address at the WIN-Forum conference in Dallas, Texas [2], stated that we should “expect dual-mode devices that operate in either the licensed or unlicensed PCS spectrum.” The FCC view is shared by the developers of the Personal Access Communications System (PACS) standard [3]. PACS is the only air interface standard which has an FDD mode to enable operation in the licensed frequency allocation and a TDD mode to enable unlicensed isochronous operation in the 1920-to-1930 MHz spectrum. The licensed and unlicensed mode standards were defined to facilitate manufacturing equipment that place both air interfaces in the same low-cost package.

The Standardization of PACS

The PACS standard is, for the most part, based on the Bell Communications Research (Bellcore) wireless access communications system (WACS) [4–7] radio system. The Bellcore WACS/PACS requirements documents along with the Bell-

core Network and Operations Plan (NOP) [8] provide a fully integrated networked approach to PCS, including mobility, data services, interoperability between licensed and unlicensed applications, and provisioning, maintenance, and administration. Both anchor radio port control unit (RPCU)-based handoff and integrated services digital network (ISDN) switch-based handoff are supported. In addition, PACS is the only PCS radio technology standard which defines both private key and public key encryption methods for authentication and privacy.

Motorola and Hughes Network Systems introduced the Bellcore WACS to the Joint Technical Committee (JTC) of the Telecommunications Industry Association (TIA) and T1 [9] in late 1993 and, with Bellcore, played the lead role in forming the WACS Technology Advocacy Group (TAG) [10]. The Hughes Network Systems proposal was to deploy a 2 GHz system based on IS-54 [11] as the high-tier radio interoperating with WACS as the low-tier radio. Motorola proposed an IS-95-based 2 GHz system for the high tier [12] and WACS for the low-tier. The WACS standards proposal was endorsed within the JTC by potential PCS service providers, including Bell Atlantic, Time-Warner, Sprint, and US WEST.

NEC, Panasonic, Hitachi, and PCSI originally proposed a low-tier air interface standard to the JTC based on the Personal Handy Phone System (PHS) [13], a Japanese low-tier air interface standard. At the urging of several service providers, they withdrew this proposal in favor of modifying the proposed WACS standard to incorporate aspects of PHS. The merger of the WACS and PHS air interface standards proposals was renamed PACS. The WACS and PHS TAGs were combined into a single PACS TAG. The PACS TAG produced a single air interface standard for operation in the licensed bands and two PACS-compatible air interface standards for operation in the unlicensed PCS (UPCS) spectrum. One unlicensed standards proposal is based on PHS and is called *PACS-UA*. The other unlicensed proposal, which is based on the original WACS/licensed PACS, is called *PACS-UB* [14]. We will focus on the PACS and PACS-UB protocols in this article.

PACS employs a very simple radio protocol. It can be easily integrated into a single handset with virtually all the existing high-tier radio standards (i.e., Advanced Mobile Phone System — AMPS; Narrowband AMPS — NAMPS, IS-95, IS-54/IS-136, and GSM/PCS 1900) with only a modest impact on

the portable cost. This article provides an overview of PACS.

Why Low-Tier?

The debate over the viability of services based on low-tier PCS radio systems has been lively, with both sides making excellent points. The Bellcore position is that both high- and low-tier services have strengths which make each viable. We expect to see equipment suppliers provide a mix of high-tier only, low-tier only and dual mode high-tier/low-tier handsets. Furthermore, we envision service providers offering capabilities that tie together high- and low-tier services to allow their customers to access the best of both services. Some key features of a low-tier PCS radio include:

- Small, inexpensive, line-powered radio ports for pole or wall mounting
- Large number of radio ports and small coverage area per port
- Low-complexity per-circuit signal processing
- Low transmit power and small batteries for subscriber units
- Capability to provide network access comparable to wire-line in
 - Quality and reliability
 - Privacy and security
 - Services and features
- Optimized to provide service to the in-building, pedestrian, and city traffic operating environments
- Cost effective to serve high traffic capacities

Table 1 summarizes the features of two low-tier PCS radio systems, PACS and the Digital European Cordless Telephone (DECT) [15, 16], and a typical high-tier PCS radio system.

PACS Architecture

Figure 1 illustrates a possible PACS functional architecture. In this architecture, the subscriber unit (SU) can be portable for a PCS or fixed for a wireless local loop application. SUs communicate with the network through the radio ports (RPs). The PACS air interface signal uses time-division multiple access (TDMA) on the uplink from SU to RP and time-division multiplexed (TDM) on the downlink from RP to SU. Wireless access fixed units convert the radio signal to an RJ-11 interface signal to the customer premises equipment. Multiple RPs (e.g., 24-100 [19]) are connected to a radio port control unit (RPCU) through the P (or port) interface. The signal for managing radio functions across the P interface is separated logically from the call traffic in an embedded operations channel (EOC). Physical transmission facility options for the P interface include E1, T1, high-speed digital subscriber line (HDSL), and digital subscriber line (DSL) technologies. The RPCU provides management and control functions between the RP and the local exchange network. RPCUs are connected to a switch through the C (or con-

Feature	PACS	DECT	Typical high tier radio
User speed	< 40 mph	< 2.2 mph [17]	< 120 mph
Max port spacing	~1300 feet*	~300 feet [18]*	>20,000 feet
Voice coder bit rate	32 kb/s	32 kb/s	8-13 kb/s
Round trip delay	6 ms	20 m	100 – 600 ms
Complexity	uplink power control no equalizer preselection diversity (portable) selection and switched diversity (port)	no power control no equalizer switched diversity (optional) may require: full selection diversity (both portable and port) equalization [17]	power control equalization full selection diversity bit interleaving convolutional coding multiple correlators or receivers

* Spacings are for pedestrian mobility and indoor services. Port spacing for wireless local loop serving arrangements may be significantly larger.

Table 1. Comparison of some features of PACS, DECT and a typical high tier radio.

trol) interface. The C interface uses an ISDN basic rate interface (BRI).

Every effort was made in the specification of PACS to allow for low-complexity implementations of both SUs and RPs in order to reduce power consumption. SU peak transmit power is 200 mW, and the average power is 25 mW. The RPs function largely as radio frequency (RF) modems, depending on the centrally located RPCUs for most of the functionality traditionally associated with RP electronics. For example, PACS RPs can be powered to 12 kft using local exchange company supply voltage of 130 V on HDSL deployed on 24- or 26-gauge copper pairs. Line powering eliminates both the need for batteries at the RP and the need to derive local power at the RP site. Another advantage of locating most of the electronics in the RPCU is that system upgrades to support new services or improve speech coders/decoders (codecs) do not require visits to RP sites. An access manager (AM) can support multiple RPCUs with network-related tasks such as querying remote databases for visiting users, assisting in network call setup and delivery, coordinating link transfer between RPCUs, and multiple RP management. The AM can reside in a service control point (SCP) [20], an intelligent peripheral (IP), or a switch adjunct [21], be combined with the RPCU in a single piece of equipment, or stand alone.

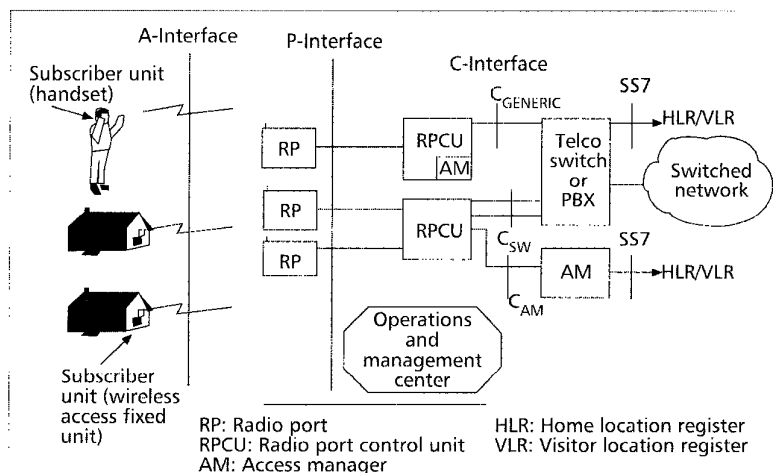
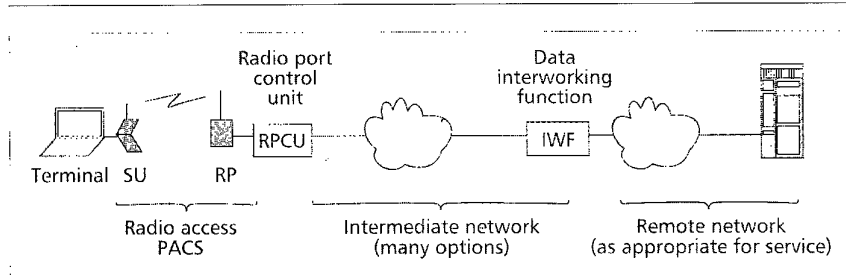

Figure 1. PACS functional architecture.



■ **Figure 2.** Generalized network architecture for wireless-to-wireline data interworking.

The PACS air interface standard includes protocol specifications for an individual messaging service, a circuit mode data service, a packet mode data service, as well as an interleaved speech/data service. Figure 2 gives a general view of the network architecture for supporting interworking of these wireless and wireline data services [22]. One approach which has been described in detail is to use X.25 on ISDN B- or D-channels for the intermediate network and to assume that the remote network is the public switched telephone network (PSTN) [23]. The *radio access system* refers to the radio devices and the (nonswitched) wireline backhaul necessary to connect the radio ports or base stations to their controllers. The controllers are connected via an *intermediate network* to the data interworking functions (IWFs). The IWF is needed to convert the digital data on the air interface to a form suitable for transmission in the other networks. The IWF must also be on a network from which the desired data application (represented as a "host") is reachable. The wireline network on which the IWF and host reside is called the *remote network*.

Broadly speaking, the IWF network element provides several main functions:

- Adapting data protocols on the radio system and intermediate network to those on the remote wireline network.
- With regard to the radio, the IWF provides for handoff between RP controllers.
- With regard to the remote network, the IWF maintains an addressable stable point for the wireline call on the remote network:
 - The IWF provides an address on the remote wireline network for the initial connection at the start of the data session.
 - It makes handoff invisible to the remote application, except for the momentary delay in data delivery.

The PACS FDD Version for Licensed PCS

As mentioned in the introduction, there are only two lower tier radio air interface protocols currently being standardized in the JTC. The two are based on DECT and PACS. The DECT-based system is optimized for indoor operation; PACS is optimized for *both* indoor and outdoor operation.

PACS Frame Structure

PACS employs TDMA/TDM on the radio interface using $\pi/4$ quadrature phase shift keying (QPSK) modulation at a symbol rate of 192 kbaud (Fig. 3). The radio frame is 2.5 ms in duration with 8 bursts/frame. Time slot 5 is reserved by the radio system to support a 16 kb/s system broadcast channel (SBC). The physical SBC contains three logical channels: the alerting channel (AC), used to alert SUs to incoming calls; the system information channel (SIC), used to broadcast system information such as identities, timers, and protocol constants; and the priority request channel (PRC), used by SUs to request emergency calls.

PACS SUs use preselection receiver antenna diversity. Preselection diversity is a fast and economic technique that is most efficient at speeds below 40 mph. Because ports transmit continuously on all time slots, an SU can make antenna diversity measurements on the RP signal just prior to receiving the specific downlink burst intended for it. Based on this measurement, the

SU makes a determination as to which antenna receives the best signal. Ports employ dual-receiver selection diversity. That is, two diversity receivers independently receive the uplink signal and, after demodulation, decide which is the better-quality signal to use. Both the ports and the SUs use switched transmit antenna diversity. Each device informs the other as to whether the previous bursts were received error-free or in error. If the bursts were received in error, the transmitting device switches to the other antenna for future transmitted bursts. The diversity channels are shown in Fig. 3.

The structure of a PACS frame and single burst are shown in Fig. 4. Each burst carries 120 bits of information including 80 bits of payload or user information and 40 bits or 20 symbols of overhead. On the downlink, the 14 bits of the sync channel provide synchronizing patterns; on the uplink, 12 bit periods are set aside for TDMA guard time, and 2 bit periods prime the differential decoder at the RP. The next 10 bits are termed the slow channel (SC), which may carry additional synchronizing patterns, word error indications, signaling information, and user data. Most user information (all speech and most data) and most signaling information are carried in the 80 bits of the fast channel (FC). The 15-bit cyclic redundancy check (CRC) is used for burst synchronization and for error detection of the contents of the SC and the FC on each burst. The one-bit power control channel (PCC) is used to optimize the power output of the SU.

The 80-bit FC, used once per 2.5 ms frame, provides a raw data rate of 32 kb/s, adequate for good-quality speech coders. PACS also supports *subrate channels* of 16 kb/s and 8 kb/s, achieved by using one burst per two frames, or one burst per four frames, respectively.

The radio channel rate selected for circuit-switched data connections may be full-rate (32 kb/s) or a subrate, depending on the efficiency of the protocol and bandwidth and delay requirements of applications. Multiple 32 kb/s time slots may be used to support higher data rates.

PACS vs. DECT-Based System: Performance Issues

DECT system designers elected to use binary phase shift keying (BPSK) modulation and a high-bit-rate signal (1.152 Mb/s). This combination provides for low-complexity SUs and is optimized for confined indoor spaces, but is not as well suited to the large root mean square (RMS) delay spreads experienced in outdoor environments or in indoor venues such as large warehouses, shopping malls, airports, and auditoriums.

To understand this issue, we need to examine radio propagation in these environments. A signal experiencing multipath propagation arrives at the receiver after traversing paths of different physical lengths. A received symbol can thus interfere with itself if the RMS differential path length or delay spread is more than 5 or 10 percent of the symbol duration [24]. In confined indoor spaces such as individual offices, RMS delay spreads above 100 ns are infrequent; however, in other more open indoor venues such as warehouses, open office spaces, and auditoriums, RMS delay spreads can be 300

ns or more. Outside buildings, the RMS delay spreads may reach 500 ns for antenna heights of no more than 10 m and cell sizes in the range of a few hundred meters to about 2000 m [25, 26]. The DECT bit rate with BPSK modulation can deal with RMS delay spreads of from 40 to 90 ns [27], more than adequate for the indoor venues for which DECT was intended; however, it is not always adequate for the wide range of delay spreads encountered outdoors. The DECT standard provides for very economic SUs by including reduced performance requirements; as a result, the lower limit seems to be more applicable according to system tests [28].

The designers of the Japanese PHS standard [29] and the North American PACS standard [30] intended these PCS protocols to operate in a wider range of environments, and therefore chose to use QPSK modulation and a lower channel bit rate of 384 kb/s. The combination results in an ability to work satisfactorily in venues with RMS delay spreads as high as 260 to 520 ns without diversity and up to 650 to 1300 ns with diversity [31–33]. Both PACS and PHS have stricter requirements on the performance of the physical layer than DECT, which may result in slightly higher-cost SUs, but the higher limits on RMS delay spread are achieved.

A radio system can survive higher RMS delay spreads if it implements additional strategies such as equalization and frequency hopping. High-tier code-division multiple access (CDMA) radio technologies such as IS-95 use multiple correlators to take advantage of multipath to improve system performance. For the low-tier time-division multiple access (TDMA) technologies we are discussing, diversity gains can be achieved using two antennas at either the SU, the RP, or both. In fact, by deploying diversity, a radio can tolerate 2.5 times more RMS delay spread [34].

The current DECT standard does not require diversity; however, simple switched diversity at the RP can be deployed. Using this technique two antennas are required, but only one receiver need be used. This simple technique can double the RMS delay spread that DECT can tolerate. Unfortunately, because the DECT system has a long frame duration of 10

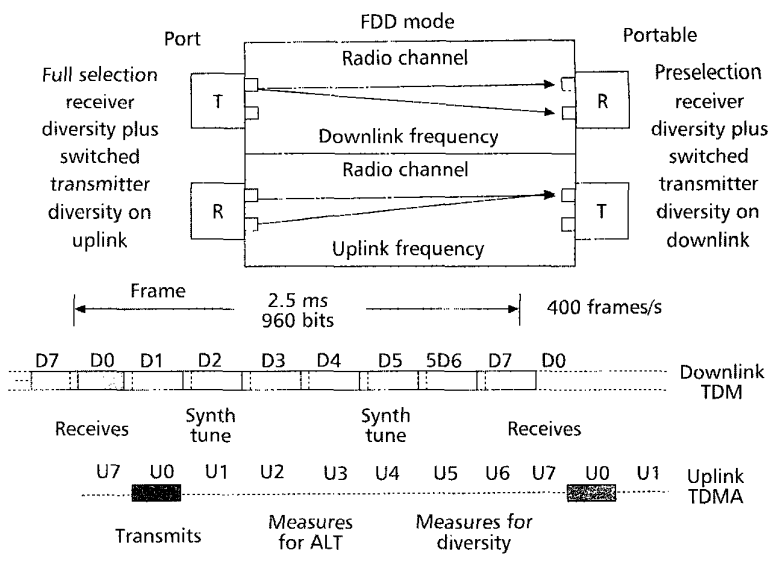

■ Figure 3. PACS frame structure.

ms, the technique will only work at user speeds considerably less than 2.2 mph or 1 m/s [17]. This is more than adequate for the indoor office environment, where users are relatively stationary, but is not useful for some pedestrian traffic or at the speeds of bicycle or vehicular traffic in downtown areas or of forklifts in warehouses, for example. Using full selection diversity (i.e., implementing two full receivers in both the SUs and the ports), the diversity improvement can be made essentially independent of user speed. With the addition of equalization, DECT-based equipment could tolerate RMS delay spreads as high as 400 ns. Of course, having to implement full selection diversity or equalization defeats the original intent of low-cost SUs.

Another difference between outdoor and indoor venues is the required RP coverage area for economic deployment in coverage limited situations. The reported range of DECT technology, for 90 percent coverage probability, is about 44 m outside buildings and 39 m inside buildings from ports located outside, without special antenna arrangements. This is largely a result of the receiver sensitivity specification for DECT. This limited range is satisfactory and, in fact, may even be desirable from an interference perspective for densely packed and confined indoor spaces; but, in the words of one DECT proponent,

"The measurements performed by British Telecom (BT) Laboratories indicate that the current DECT specification will not be adequate to provide a cost-effective local access service ... If greater than 90 percent coverage is required, then these cell sizes drop dramatically [35]."

The PACS specification for receiver sensitivity plus the PACS 2 X 2 diversity (preselection and switched) results in a deployment advantage of 1 PACS RP for every 7 to 15 DECT ports, assuming an exponential propagation loss factor of 3.5. Because of the short 2.5 ms frame structure, the preselection diversity gain is reduced by only 3 dB at speeds up to 38 mph [36].

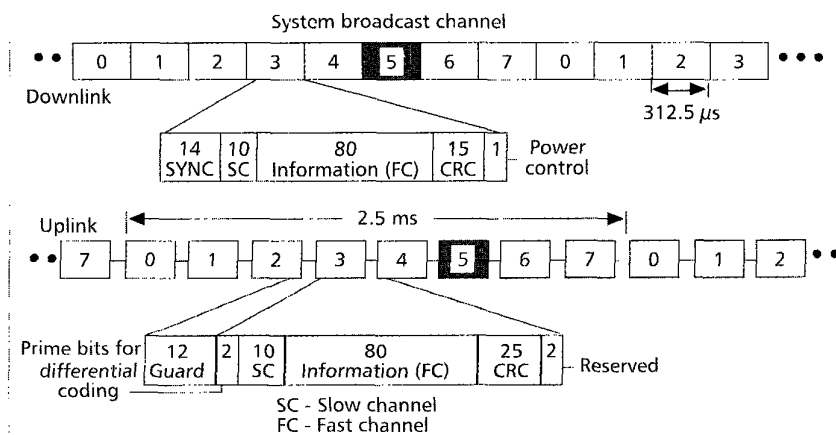

■ Figure 4. PACS frame and burst structure.

Advantages of the PACS Frame Structure

The advantages of a short frame structure cannot be overstated. Varma *et al.* [37] have shown that frame erasure lengths have an impact on the recovery time of speech quality in the presence of radio link errors. Longer system frame lengths lead to longer speech frame erasures, which in turn lead to slower recovery of speech quality for the International Consultative Committee for Telephone and Telegraph (CCITT) standard adaptive differential pulse code modulation

Much commonality exists between PACS and PACS-UB for terminal interoperability. The air interface rate, frame length and structure, signaling protocol, and channel bandwidth are similar for both systems, and the hardware impact is minimal.

(ADPCM) decoders. For example, for 2.5 ms erasures, the decoded speech signal recovers to within 3 dB of the error-free signal (in terms of signal energy) within 5 ms after restoring correct transmission for 80 percent of burst errors. For 10 ms erasures, the 80th percentile delay for recovery to within 3 dB of error-free speech is 35 ms. Therefore, systems with shorter frame lengths can provide more robust speech quality in the presence of link errors.

Because of the relatively large alerting channel bandwidth in the dedicated SBC, PACS has the ability to support up to 200,000 users per alerting/registration area (ARA) with approximately zero probability of alert blocking [38–39]. PACS supports an effective polling procedure which can be implemented as required by a service provider. This feature allows the service provider to use an implicit deregistration [40] process in the network to reduce network signaling between home location registers (HLRs) and visited location registers (VLRs). This feature is effective and nondisruptive because the alert blocking for call delivery is virtually nonexistent; and also because the access collision probability, even during the busy hour and with highly mobile users (i. e., at highway speeds), is less than 1×10^{-8} [41]. ARAs can be made arbitrarily large, which considerably reduces registration traffic when compared to other low-tier radio technologies.

PACS Frequency Planning

RP operating frequencies are assigned automatically and autonomously, eliminating the need for manual frequency planning. The automatic frequency assignment is called quasi-static autonomous frequency assignment (QSAFA) [42]. QSAFA is a self-regulating means of selecting individual RP frequency channel pairs that functions without a centralized frequency coordination between different RPs. The QSAFA process is controlled by the RPCU for its associated RP transceivers. To start the procedure, the RPCU sends a message to a transceiver to turn off its transmitter. The transceiver is instructed to tune to the downlink frequency band and scan all possible downlink frequencies. Then the transceiver reports the signal power of the frequencies back to the RPCU and amplitude modulation (AM). The frequency with the lowest received signal power at the RP is selected. Finally, the RP transmitter turns to the selected frequency and turns on.

The frequency assignment procedure is repeated by all ports one at a time until no ports request a change in their assigned frequencies for two consecutive cycles. The procedure can be repeated until the algorithm converges or until a threshold number of iterations is reached. Because the down-

link transmitter must be turned off briefly during the measurement, the measurement should be conducted during low-traffic hours. Simulation study indicated that for 256 ports using 16 frequency pairs, the assignments can always be stabilized within fewer than five iterations. QSAFA combines the principal advantage of dynamic channel allocation in that pre-engineering of a frequency plan is unnecessary with the performance advantages of a fixed frequency assignment; that is, elimination of blind time slots for channel assignment, elimination of call blocking due to resource blocking, and faster call setup and handoff times [43].

Dynamic channel allocation for TDMA systems is subject to blocking from two sources: interference blocking, whereby the desired channel is blocked due to interference; and resource blocking, whereby the desired channel is blocked because the same time slot (not the same channel) is already in use at the target RP [44]. This resource blocking probability seems to be higher than Erlang-B blocking because of the blind time slot problem. There are two aspects to this problem. The obvious one is that SUs in handoff cannot see the time slot channels they are using or adjacent time slots. The second problem is that SUs attempting initial access or handoff may know the target or best RP, but they do not know the traffic pattern on that RP (i.e., which time slots may be in use on other frequencies). As a result, these SUs attempt access to ports on time slots already in use, albeit on a different frequency, and the RP cannot hear them. This problem can be solved by the transmission of blind slot information from each RP on the control channel, at the cost of reducing alerting or system information capability.

PACS-UB for Unlicensed Operation

The FDD PACS air interface protocol also supports two TDD protocols intended for use in the unlicensed frequency allocation. This tends to cause confusion among those who are not intimately familiar with the JTC proceedings. The PACS TAG in the JTC was formed by a merger of the initially separate PHS and WACS TAGs, as mentioned earlier. The supporters of the PHS radio air interface protocol realized early on that a TDD radio system would have difficulty operating over a spectrum allocation intended for FDD. They also appreciated the importance of a unified radio system approach which includes licensed and unlicensed interoperability (i. e., an FDD mode of operation and a TDD mode of operation). This marriage between the two systems has been successful, and the contribution of the PHS proponents to the improvement of the PACS standard has been significant.

The goal of the PACS TAG is in accord with the FCC's goals of interoperability between licensed and unlicensed services. We believe there are benefits in allowing multiple unlicensed radio air interface standards. The need for private unlicensed radios to be compatible is just not as important as in the licensed public arena. Therefore, the WACS and PHS proponents joined their efforts to support one low-tier PCS licensed radio intended for public systems but, at the same time, foster competitive solutions for unlicensed applications. Thus, there are two very viable unlicensed PCS (UPCS) radios, one based on PHS (PACS-UA) and one based on the original WACS (PACS-UB), which are at the same time compatible with the PACS low-tier standard. Both low-tier versions are American National Standards Institute (ANSI) regular air interface standards [45, 46].

PACS-UB UPSC Standard Air Interface

PACS-UB [47, 48] is based on WACS, with modifications to conform to the FCC etiquette rules for the unlicensed spectrum. The PACS-UB protocol was designed with several guidelines in mind:

- A dual-mode SU terminal capable of both PACS and PACS-UB operation should be only slightly more complex than a single-mode PACS terminal.
- PACS-UB should use the PACS higher-layer protocols to facilitate service interoperability (e.g., automatic registration between licensed and unlicensed spectrum access modes).
- Channel scanning, access rights determination, and channel access for PACS-UB should be fast to facilitate service interoperability.
- PACS-UB should retain from PACS the system design philosophy that emphasizes inexpensive, highly reliable, and simple infrastructure.
- PACS-UB should be robust in the presence of interference from unlike and/or unsynchronized systems that share the same spectrum.
- The protocol underpinnings of PACS-UB should scale gracefully with system size and teletraffic capacity requirements, from large-office wireless Centrex systems, to multiline key sets in small business environments, down to residential use of cordless home ports.

PACS-UB Frame Structure

PACS-UB employs TDMA/TDM (uplink/downlink) on the radio interface using $\pi/4$ QPSK at 192 kbaud/s. The 2.5 ms radio frame consists of eight 312.5-ms bursts, numbered 0 to 7 (Fig. 5) and four duplex paired time slots. Each time slot provides a raw bit rate of 32 kb/s, suitable for good-quality speech coders. PACS uses FDD, whereas PACS-UB employs TDD operation because sufficient duplex separation is not available to isolate the uplink and downlink transmission in the unlicensed band. For PACS-UB, bursts 2, 3, 6, and 7 are used for RP-to-SU transmission, and bursts 0, 1, 4, and 5 are used for SU-to-RP transmission. These bursts are paired as follows: (0,2), (1,3), (4,6) and (5,7), to form duplex channels as shown in Fig. 5. Thus, PACS-UB has 4 servers/frequency channel and 32 frequency channels in the 10 MHz isochronous unlicensed band.

Because the uplink and downlink for PACS-UB use the same frequency channel, the system can take advantage of the reciprocity of the radio channel and use transmit diversity at the RP to achieve downlink diversity protection, as shown in Fig. 5. The performance of this form of diversity is limited by the time delay between the uplink burst received at the RP and the transmission of the downlink burst using the antenna which the RP determined received the best-quality uplink signal. The diversity protection for PACS-UB should be good for user speeds up to about 19 mph.

Several features of PACS make it particularly amenable to (modified) operation in 1.9 GHz unlicensed spectrum.

Its short frame structure and low end-to-end delay allow fast frequency scanning by SU terminals, eliminate the need for echo control processing in full-rate (32 kb/s traffic channels, and allow subrating down to 8 kb/s traffic channels.

Its narrowband transmission format creates a relatively large number of frequency channels in the 10 MHz allocations, which should be advantageous in conditions of high intersystem interference.

Finally, its emphasis on low-cost, low-complexity hardware is highly amenable to a radio technology that could span both residential and business uses.

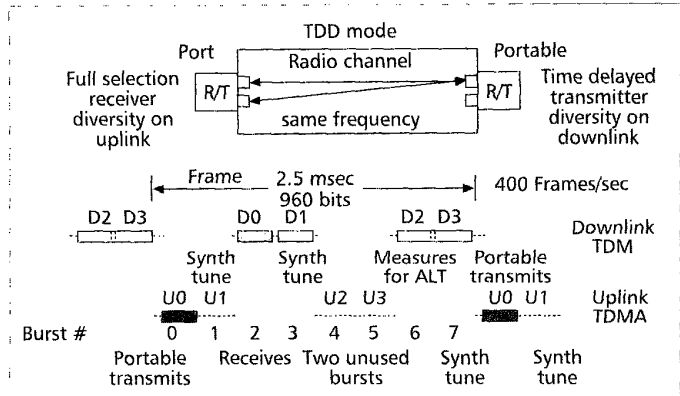

Figure 5. TDMA/TDD frame structure for PACS-UB.

Licensed and Unlicensed Interoperability

Other features of PACS-UB facilitate licensed/unlicensed interoperability.

- It has more system information capacity than any other unlicensed technology, which provides for frequent broadcasting of system identification, effecting rapid and efficient automatic registration to the unlicensed service.
- It supports 80,000 registered users per alert/registration area with approximately zero alert blocking. This alerting capability allows for efficient and reliable polling. Polling deregistration is a powerful and effective method of deregistering the SU from the unlicensed system [49].

While in licensed mode (i.e., not currently registered to an unlicensed private system) an SU can scan periodically for an unlicensed system or RP to which it has access rights. This takes about 200 ms. If no suitable ports are found, then the SU can return to standby mode, registered to the licensed public low-tier and/or high-tier system. This performance is better than other systems because of the frequent broadcasting of access rights and system identities, and also because of the 2.5 ms frame structure. Channel acquisition takes less than 20 ms. For comparison, consider the DECT system and its derivatives, in which channel acquisition for SUs already synchronized to the system takes 258 ms on average and more than 570 ms for 10 percent [50]. The average channel acquisition time can be improved to 127 ms or even 40 ms provided the ports transmit blind slot information. The problem with this technique of improving channel acquisition time is that it is at the expense of alerting capacity and/or transmission of access rights.

Much commonality exists between PACS and PACS-UB for terminal interoperability [51]. The air interface rate, frame length and structure, signaling protocol, and channel bandwidth are similar for both systems, and the hardware impact is minimal.

PACS-UB Superframe Structure

Both PACS and PACS-UB assign a time slot for broadcasting system information. This channel is designated the system broadcast channel. The SBC is asymmetric in that it is primarily used in the downlink. Its uplink is used by access requests. There is a superframe structure associated with the SBC, referred to as the *SBC-SF* [52]. The SBC-SF is composed of a group of 400 consecutive frames and is 1 s in duration. The SBC-SF is used to allow the SBC to carry a number of logical channels (the alerting channel, the system information channel, and the access request channel).

In performance of the channel access etiquette, RPs employ two different structures of the SBC-SF known as the *basic SBC-SF* and the *access SBC-SF*. The structure of the basic SBC-SF is illustrated in Fig. 6.

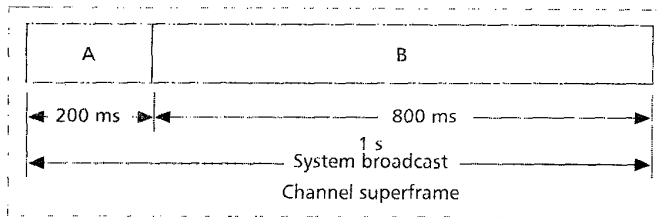

■ Figure 6. Basic SBC-SF structure.

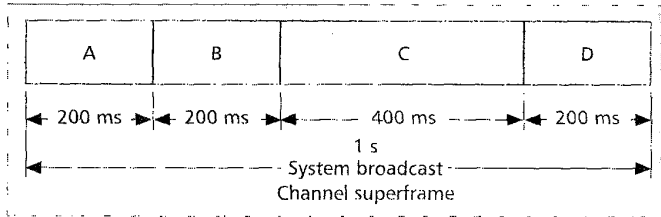

■ Figure 7. Access SBC-SF structure.

The basic SBC-SF is further divided into two intervals, interval A and interval B. During each of these intervals the SBC is used as follows:

- Interval A (200 ms) — The SBC downlink carries the alerting channel (AC) and the access request channel (ARC).
- Interval B (800 ms) — The SBC downlink carries the system information channel (SIC) and the ARC.

The basic SBC-SF structure is employed by the RP for most transmissions. However, a unique structure is utilized by the RP upon execution of the RF channel access procedure. This unique structure (the access SBC-SF) is shown in Fig. 7.

This access SBC-SF structure reserves an interval for the RP to perform the required RF channel search process. The access SBC-SF structure is divided into four intervals, used as follows:

- Interval A (200 ms) — The downlink SBC carries the AC and the ARC.
- Interval B (200 ms) — The downlink SBC carries the SIC and the ARC.
- Interval C (400 ms) — The RP searches for an acceptable RF channel and, upon identification of an acceptable channel, the SBC carries the ARC.
- Interval D (200 ms) — The downlink SBC carries the ARC.

In order to conform to the access etiquette, an RP must initially employ the access SBC-SF to select a suitable RF channel for transmission. Following successful identification of an RF channel, an RP uses the basic SBC-SF format for further transmissions for up to 30 s of unacknowledged transmission. Without receipt of a transmission from an SU, the RP must employ the access SBC-SF structure at least once every 30 s (i.e., a single access SBC-SF followed by, at most, 29 basic SBC-SFs). This process (as shown in Fig. 8) ensures that the RP relinquishes its selected RF channel each 30 s unless the channel has been used for SU activity.

PACS-UB Frequency Assignment

The RP searches for an available RF channel in a specific manner, described by the etiquette state diagram shown in Fig. 9.

Upon initial power-up, the RP begins in the idle state. When it reaches interval C in its first SBC-SF, it moves to the Measurement state and begins to measure received signals on channels within the frequency band until an acceptable channel is identi-

fied. An acceptable channel is defined as the first channel that has a received signal strength measurement less than T_h above kTB, where $0 \text{ dB} \leq T_h \leq 30 \text{ dB}$ and kTB is -118.2 dBm at 27 C.

If the RP measures all RF channels and fails to identify an acceptable channel, it may reinitiate its measurement process using a higher limit for received signal strength indication (RSSI). This limit may be raised as high as 50 dB above kTB for subsequent measurements. If a channel is selected with an RSSI higher than 30 dB above kTB, the RP (and any SUs with which it communicates) must proportionally reduce output power. For example, if a channel is selected which provides an RSSI measurement of 35 dB above kTB, transmit power for all devices using that channel must be reduced by 5 dB below the allowed maximum power levels.

When an acceptable channel has been found, the RP moves to the Xmit state, where it remains (using the basic SBC-SF) until it is required to again perform the access procedure or it receives an access request from an SU. When the RPCU determines that an RP must relinquish the channel, it sends a broadcast directive in interval A of the access SBC-SF to inform all SUs that the RP is relinquishing the channel.

Upon receipt of an access request from an SU, the RP moves to the Busy state. The RP remains in the Busy state as long as a call is present on any of its traffic channels. When the RP no longer has a call present, it returns to the Xmit state. The RP must return to the Measurement state at least once every 8 hr even if it is carrying an active traffic channel.

To access a channel, the SU scans the 32 frequency channels and measures the corresponding signal strength (RSSI). The SU rank orders the frequency channels and tries to access the system on the strongest channel. If the desired RP is not busy and the downlink signal-to-noise/interference Ratio (SINR) is above 17 dB (the level that results in a good word error rate performance), then the SU access is successful. Otherwise, the SU can attempt to access the second strongest channel. We call this rerouting the access to the second RP. Once an SU accesses an RP successfully, the RP then assigns the best available time slot (the time slot that encounters minimum interference on the uplink) to the SU.

Propagation Model	1%-tile SINR(dB)		Median SINR(dB)		Blocking Probability
	Uplink	Downlink	Uplink	Downlink	
Ericsson	17.8	17.5	34.3	35.1	1.5 %
Bellcore	18.0	17.6	36.7	37.9	0.8 %

■ Table 2. Performance of first percentile SINR vs. threshold for 10 m RP separation.

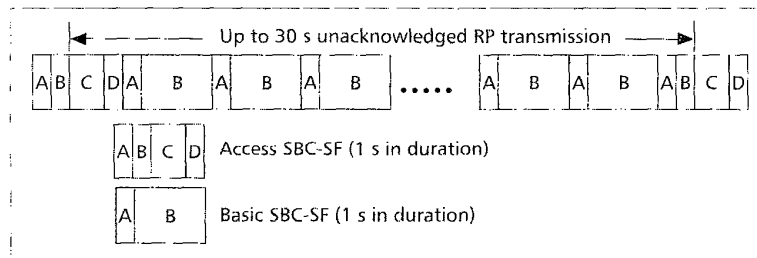

■ Figure 8. Unacknowledged SBC-SF sequence.

PACS-UB Performance

The performance of the PACS-UB radio protocol is summarized in Table 2 for two indoor propagation models, the Ericsson model [53] and the Bellcore model [54]. The capacity of this system is 0.02 Erlangs/m², which corresponds to 20,000 Erlangs/km² or 432 users in a 60 x 60 sq. m area and 0.2 Erlangs/user. This traffic capacity is the best reported in the literature for any radio technology being proposed for UPCS.

General Features of PACS

In this section features of the PACS system which are shared by the TDD operating mode, intended for use in the UPCS frequency allocation, and the FDD operating mode, intended for use in the licensed PCS spectrum, are described

Radio Link Maintenance

When the SU is on (either busy or idle), it must take measurements to monitor its RF environment [55]. Both the RP and the SU make measurements on every time slot. Three measurements are considered for link maintenance.

- The RSSI is a measure of co-channel interference power and noise.
- The quality indicator (QI) is the estimate of the "eye opening" of a radio signal, which relates to the ratio of signal to interference plus noise, including the effects of dispersion. A poor QI indicates that the power needs to be raised. If so, the PCC is set to 1, and the SU will raise its transmit power.
- The word error indicator (WEI) is an indication of whether one or more bit errors occur in a time slot due to any radio link degradation. The SU uses the WEI to indicate the performance of the uplink.

These measurements are used for automatic link transfer (ALT) or handoff, time slot transfer (TST), and power control. The SU determines when and to which RP to perform ALT or TST. The SU output power is controlled by the RPCU by using the PCC. The ALT and TST decisions are made by the SU in order to offload this task from the network and to ensure robustness of the radio link by allowing reconnection of calls even when radio channels suddenly become poor.

The SU first measures the radio signals. If certain criteria are reached based on the measurements, ALT or TST is performed. The SU determines the new RP for ALT or the new time slot for TST, and executes the transfer with the network.

ALT is initiated if the SU finds a channel with (filtered) RSSI exceeding that of the current channel by a threshold value (e.g., 6 dB). If several channels are qualified for ALT, the best channel is selected based on the QI and WEI measures. To avoid a large number of ALTs during a phone call, the SU does not initiate two consecutive ALTs within a timeout period. TST is handled in the similar context.

To provide adequate uplink performance (i.e., low error rate), an SU tends to transmit more power than necessary. Because more power causes more interference, uplink power control is required.

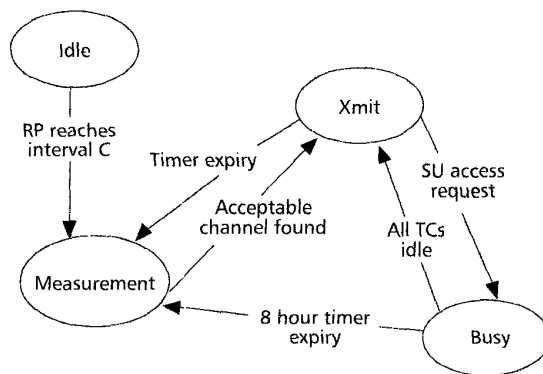

Figure 9. Etiquette states.

The QI is used as input to the power control procedure because it is a good relative measure of signal-to-interference ratio (SIR). However, when an RP receiver is saturated, the QI is degraded because of distortion, and its indication may result in requesting more power than necessary. This situation can be detected by using the RSSI. Note that the RSSI is a measure of the received signal, noise, and interference, and its threshold is adjusted by the WEI to provide adequate SIR indication. The WEI is also used to adjust QI for asynchronous RP operations.

The SU States

The SU maintains phase lock with the serving RP to receive alerts and broadcast messages. For the SU, the radio link is in one of the four states OFF, ACQUIRING, STANDBY, and ACTIVE, shown in Fig. 10.

The OFF State – The SU moves to the OFF state from the other three states when it is powered off. In Fig. 10, we only show the power-off transition from ACQUIRING to OFF.

The ACQUIRING State – If the SU is powered on (from the OFF state) or loses synchronization (with the RP) in the STANDBY/ACTIVE states, it moves to the ACQUIRING state. When the SU enters the ACQUIRING state, it scans frequencies to select a suitable RP signal. When the SU achieves phase lock with an RP, it enters the STANDBY state.

The STANDBY State – When the SU enters the STANDBY state, it first listens to the SBC to determine if registration is necessary. In the registration process, the SU is assigned an Alert ID.

The ACTIVE State – If the SU attempts to communicate with the network (e.g., registration, call origination/termination, etc.) at the STANDBY state, the SU seizes a time slot and enters the ACTIVE state. The SU typically accesses the traffic channels. If no traffic channel is available, the uplink of the SBC is used by the SU to alert the RPCU for an emergency call. When the time slot is released, the SU moves back to the STANDBY state.

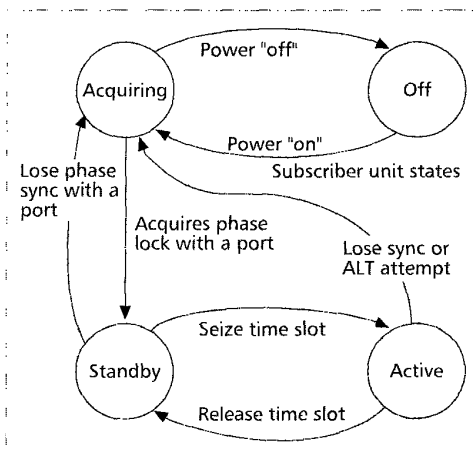

Figure 10. The SU states.

The Alerting Protocol

When an SU enters a new registration area, it is assigned a unique alert ID within that registration area. The alert ID consists of two parts: the alert phase and the alert number. The AC is divided into a number of alert phases. A 16 kb/s SBC has up to 50 alert phases, and an 8 kb/s SBC has up to 18 alert phases. In principle, an alert phase can accommodate 4000 SUs. If a large number of SUs are accommodated in an alert phase, increased power consumption is expected when an SU listens for alert in the STANDBY state. Each alert message carries up to 16 alert values. In the STANDBY state, an SU only listens for its alert number to be broadcast during its assigned alert phase. The listening period ranges from 312 μ s to 12.5 ms out of every 1 s alerting superframe period. Because this "listening" operation consumes little power, the battery life of the SU can last longer.

The capacity of the PACS alerting protocol is 200,000 SUs per alerting area. Assuming 1 percent alert blocking rate, DECT can accommodate 22,000 SUs per alerting area and CT-2 [56] accommodates 200 SUs. Because the alerting cost of PACS is inexpensive, relatively large alerting areas can be accommodated to reduce the registration traffic.

The Automatic Link Transfer (Handoff)

Three ALT (handoff) strategies have been proposed for PCS networks:

- In SU-controlled handoff (e.g., PACS and DECT) the SU continuously monitors the signal strength and quality from the accessed RP and several handoff candidate RPs. When

P*PACS supports basic call control features such as call delivery and call origination as well as vertical features such as call origination, three-way calling, and call waiting.*

some handoff criterion is met, the SU checks the best candidate RP for an available traffic channel and launches an ALT request.

- In network-controlled handoff the RP monitors the strength and quality of the signal from the SU. When the signal deteriorates below some threshold, the network arranges for an ALT to another RP. The network asks all the surrounding RPs to monitor the signal from the SU and report the measurement results back to the network. The network then chooses a new RP for the handoff and informs both the SU (through the old RP) and the new RP. The handoff is then effected.
- In SU-assisted handoff (e.g., Global System for Mobile Communications — GSM [57]) the network asks the SU to measure the signals from surrounding RPs and report those measurements back to the old RP so that the network can make the decision as to when a handoff is required and to which RP.

The PACS architecture in Fig. 1 introduces five ALT cases:

- The TST is a transfer from one channel (time slot) to another in the same RP. The transfer time is a few milliseconds in WACS.
- The intra-RPCU ALT is a transfer from one RP to another RP on the same RPCU.
- The inter-RPCU ALT is a transfer between two RPs on the different RPCUs but on the same switch.

- The interswitch ALT is a transfer between two RPs on different RPCUs and switches.
- The inter-AM ALT is a transfer between two RPs on the different RPCUs for the different AMs.

The SU does not distinguish between types of ALT and uses the same protocol to make the request. We use the PACS inter-RPCU transfer as an example to illustrate the ALT process. In the SU-controlled strategy, the SU determines if an ALT is necessary. If so, it selects the new RP for the ALT. Consider the inter-RPCU case.

- The SU temporarily suspends the conversation and requests an ALT by signaling on an available traffic channel in the new RP. Then it resumes the conversation on the old RP (see Fig. 11a).
- Upon receipt of the signal, the AM transfers the session privacy key to the privacy coder associated with the new channel. The switch creates a new conversation path to the SU through the new channel and bridges the new path with the old path. The network then informs the SU to transfer from the old channel to the new channel (Fig. 8b and c).
- After the SU has transferred to the new RP, it signals the network for ALT completion, and resumes conversation by using the new channel (Fig. 8c and d).
- Upon the receipt of the ALT completion signal, the network removes the bridge from the path and releases resources associated with the old channel. An ALT may fail if no network resources (such as bridge or channel card) are available.

An alternative to the above inter-RPCU ALT is the anchor-RPCU ALT. The anchor method also applies to interswitch handoff. The concept of the PACS anchor-RPCU ALT is similar to the intersystem handoff in IS-41[58], which is an anchor switch handoff. In this method, no matter how many inter-RPCU ALTs occur during a call, the originating RPCU or the anchor RPCU (i. e., the RPCU through which the call was originally established) is always in the call path between the network and the new RPCU that provides the radio link to the SU.

When the first inter-RPCU handoff occurs in a call, a new connection is established between the Anchor RPCU and the Target RPCU (similar to the Handoff-Forward in IS-41).

If the SU moves to a third RPCU, the connection to the second RPCU is dropped, and the anchor RPCU is connected to the third RPCU directly. In IS-41 Handoff-To-Third, the connection through the second mobile switching center (RPCU in our example) may or may not be included in the call path. If the SU moves from the target RPCU back to the anchor RPCU, the connection between the anchor RPCU and the target RPCU is torn down (similar to the Handoff-Back in IS-41).

The anchor-RPCU ALT has the advantage that the handoff is transparent to the network. The disadvantage is that it requires more resources to connect the anchor RPCU and the target RPCU.

Registration/Deregistration

Registration is the process by which SUs inform the network (i.e., the AM) of their current location (i. e., registration area — RA). When an SU enters an RA, either when it is powered on or when it moves between RAs, it registers at the visitor location register (VLR), which may or may not be collocated with the AM corresponding to the RA, and the address of the new RA is reported to the home location register (HLR) of the SU. Then, depending on the deregistration strategy, the HLR may send a deregistration message to the old VLR from

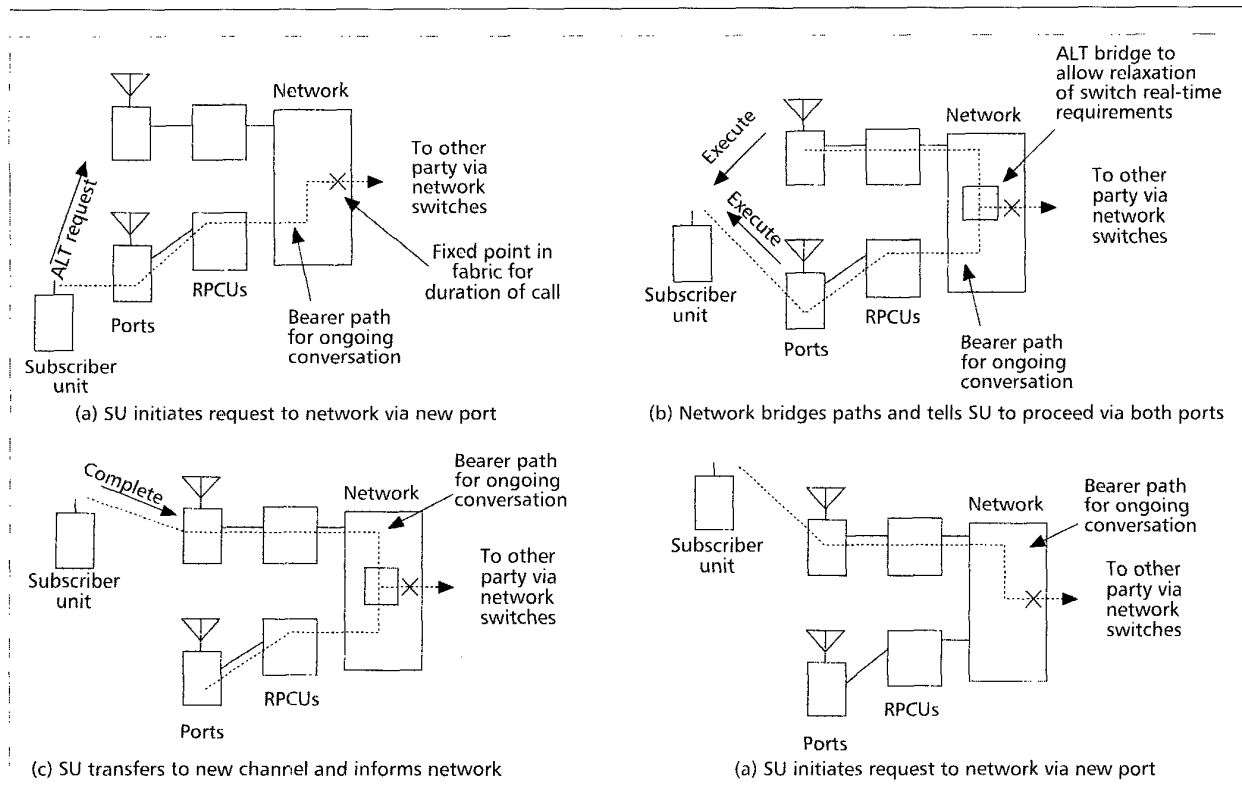

■ Figure 11. Inter-RPCU ALT.

which the SU just departed to delete the obsolete VLR record. To locate an SU, its HLR is accessed to find the current RA address of the SU.

In IS-41 [59], the registration process ensures that an SU's registration in a new RA causes deregistration in the previous RA. The deregistration process may occur at any time after the corresponding registration process. This approach is referred to as *explicit deregistration*. Such deregistration may create significant traffic in the network [60]. Also, explicit deregistration cannot deregister an SU that is shut off, broken, or otherwise disabled for a significant period of time.

PACS suggests that an SU be deregistered by default after a certain time period elapses without the SU reregistering (i.e., timeout deregistration [61] or polling deregistration). A fast polling capability has been included in PACS-UB. In this approach, an SU registered in an RA is periodically polled by receiving an alert in the normal fashion (i.e., as if the network has an incoming call to be delivered to the SU). The SU responds to the alert to indicate that it is in the RA. The polling process is handled at the data link layer on the air interface and should take no longer than 10 or 20 ms. If the SU does not respond to an RPCU polling within a timeout period, it is deregistered from the RA.

Another possibility mentioned in PACS is to perform deregistration implicitly. The details of *implicit deregistration* are not included in the PACS specification but are elaborated in [62]. Suppose that the VLR is full when an SU p arrives at an RA. Implicit deregistration assumes that the record with the oldest time stamp (i.e., the time when the SU registered in the VLR) is obsolete. This record is deleted and is reassigned to p . When an SU moves, its HLR record is updated to point to the VLR which contains the valid record of the SU. When the system attempts to locate the SU, the HLR record is accessed to find the valid VLR record, and the system is never confused by the multiple obsolete records. The only impact of the obsolete records is that they are not detected immediately,

which increases the probability that a valid record is replaced and the corresponding SU is forced to deregister. Thus, the size of a VLR must be sufficiently large to ensure low probability that a valid registration record will be replaced.

Call Control

PACS supports basic call control features such as call delivery and call origination as well as vertical features such as call origination, three-way calling, and call waiting.

The PACS call control shares the same features with IS-41. One exception is call delivery. In PACS, the SU is paged by the VLR before a routing address is returned to the HLR; thus, if the SU is turned off the call will not be routed, and the HLR can implement an alternative call treatment as per the called party's profile, such as routing the call to a voice mail service or making an announcement. In the IS-41 protocol the VLR returns a routing address without paging the SU and confirming its presence, and therefore the call is routed to the mobile switching center before the SU is alerted. In this case, if the SU is unavailable the call is routed unnecessarily and there may be some delay in implementing an alternative call treatment.

Security

The goal of the PACS security mechanisms is to make it impractical for an eavesdropper to obtain sufficient information for perpetrating usage fraud. PACS security addresses the following issues:

Authentication and Key Agreement (AKA) Protocol – The PACS AKA protocol supports either a public-key AKA protocol [63] or a private-key AKA protocol [64].

Radio Link Encipherment – This process protects radio information against interception by eaves droppers. Privacy of a traffic channel is guaranteed by radio link encipherment. A

cipher algorithm following the United States Data Encryption Standard [65] may be used in PACS to scramble the bits of the FC communication stream. The cipher requires a session key. For a newly initiated channel, the session key is generated by the AKA protocol. A PACS mechanism called the *security menu* allows flexibility in support of security services. The security menu is provided in the SIC as a 4-octet field. The first two octets indicate the available AKA procedures; the second two octets indicate the available link encipherment algorithms and modes of operation. During ALT, the session key is transferred to the new serving RPCU, and retained for the duration of the call.

Authentication — SU authentication verifies if a proffered SU identifier is true. It is necessary that the service provider assign a unique identifier to an SU to have strong authentication. An SU's secret information may be removed to create a cloned SU for fraudulent access. The "major event parameter" or "call counter" (which indicates the call history of an SU) can be used to detect a cloned SU. Network authentication is a process whereby an SU ensures that an accessed network RP is legitimate. Network authentication is required to prevent potential fraud perpetrators from impersonating a network RP.

PACS Data Services

The individual messaging service can deliver messages up to 16 Mbytes in length. The delivery is secure and protected by an error and flow control protocol, and the contents are ciphered to ensure privacy. The applications include text messages, e-mail, Group III fax imaging, as well as graphics imaging, PCM and ADPCM encoded sound, Motion Picture Experts Group (MPEG) video, and more. The PACS individual messages are implemented by minor modifications of the PACS call control messages based on layer 2 acknowledgment mode protocol (AMP). The AMP can be used to efficiently implement individual messages with little extra complexity.

The circuit mode data service is a nontransparent-mode data service in which data is enciphered for privacy and the data integrity is protected by error and flow control protocol, link access protocol for radio (LAPR). The round-trip delay of the PACS air interface, including the transport delay of the RP-to-RPCU interface and the RPCU processing time, is on the order of a few tens of milliseconds. This compares favorably with, for example, the 200 to 600 ms round-trip delay for acknowledgments in the nontransparent-mode radio link protocol (RLP) of the GSM radio air interface. The data throughput in a 32 kb/s channel is about 28 kb/s under extreme operating conditions.

The packet mode data service is a shared contention-based RF packet protocol using a data sense multiple access (DSMA) contention mechanism. The downlink uses near-perfect scheduling. The basic structure of the packet channel allows operation of subscriber units that are capable of operating on a single time slot per TDMA frame as well as subscriber units that achieve higher throughput and lower packet delays by using multiple time slots per frame. The protocol allows both types of subscriber units to share the available packet bandwidth in a fair and equitable manner.

The interleaved speech/data service provides the ability to transmit both speech information and data information by using a single 32 kb/s time slot. Data is transmitted during the quiet times between speech bursts. An interesting advantage of this mode of operation is that handoffs are more reliable because only one 32 kb/s channel need be set up to the new RP. Data bursts are reliably delivered by the LAPR protocol and, as with all PACS data services, enciphered for privacy.

Conclusions

This article provides a general overview of the PACS and PACS-UB radio systems. The PACS and PACS-UB radio air interface standards represent the only dual-mode radio system which has been designed to operate in both the licensed PCS and unlicensed (UPCS) spectrum. Interoperability between low tier-public licensed wireless access systems and private unlicensed wireless access systems has been built into the radio system design. The salient features of PACS are summarized below:

- Dual-mode operation: FDD for licensed PCS spectrum and TDD for UPCS spectrum.
- Low-complexity RPs and SUs (with low duty cycle standby mode) consume low power.
- Short radio time frame supports low-delay/high-quality voice.
- QSAPA provides automatic frequency assignment.
- Inexpensive alerting protocol allows large registration areas.
- Priority access accommodates emergency calls when no traffic channel is available.
- The SU controlled handoff supports fast, reliable ALTs.

Acknowledgments

The authors would like to thank all of the people who contributed to the development of the PACS wireless access system, especially Don Cox, Nelson Sollenberger, and Ken Felix. Doug Alston, Hamid Ahmadi, and the reviewers provided useful comments to improve the quality of this article.

References

- [1] FCC Memorandum Opinion and Order, "Amendment of the Commission's Rules to Establish New Personal Communications Services," GEN Docket No. 90-314, June 13, 1993.
- [2] J. Knapp, "Making User PCS a Reality — A Journey on the Information Highway," First Annual WINForum User PCS Workshop, Dallas, TX, Oct. 17-19, 1994.
- [3] N. R. Sollenberger and H. W. Arnold, "Interoperable Licensed and Unlicensed Wireless Access for PCS," *IEEE Third Annual Int'l. Conf. on Universal Personal Commun. Conf. Rec.*, Sept. 27-Oct. 1, 1994, San Diego, CA., pp. 109-113.
- [4] TR-INS-001313, "Generic Criteria for Version 0.1 Wireless Access Communications Systems (WACS)," Issue 1, Bellcore, Oct. 1993, Rev. 1, June 1994.
- [5] D. C. Cox, "Universal Digital Portable Radio Communications," *Proc. IEEE*, vol. 75, Apr. 1987, pp. 436-77.
- [6] D. C. Cox, "A Radio System Proposal for Widespread Low-Power Tetherless Communications," *IEEE Trans. on Comm.*, Feb., 1991 pp. 324-35.
- [7] V. K. Varma *et al.*, "A Flexible Low-Delay TDMA Frame Structure," *Proc. IEEE ICC '91*, Denver, CO, June 23-26, 1991.
- [8] Bellcore, "Network and Operations Plan for Access Services to Personal Communications Services Systems," Issue 2, Tech. Rep. SR-TSV-002459, Bellcore, 1992.
- [9] C. I. Cook, "Development of Air Interface standards for PCS," *IEEE Pers. Commun.*, vol. 1, no. 4, 4th Qtr., 1994, pp. 30-34.
- [10] ANSI J-STD-014, "Personal Access Communications System," 1995
- [11] EIA/TIA, "Cellular System Dual-Mode Mobile Station — Base Station Compatibility Standard," Tech. Rep. IS-54, EIA/TIA, 1992.
- [12] EIA/TIA, "Mobile Station-Base Station Compatibility Standard for Dual-Mode Wideband Spread Spectrum Cellular System," Tech. Rep. IS-95, EIA/TIA, 1993.
- [13] I. Horikawa and M. Hirono, "A Multi-Carrier Switching TDMA-TDD Microcell Telecommunications System," *IEEE VTC Conf. Proc.*, May 1990, pp. 167-71.
- [14] D. G. Steer, "Coexistence and Access Etiquette in the United States Unlicensed PCS Band," *IEEE Pers. Commun.*, vol. 1, no. 4, 4th Qtr., 1994, pp. 36-43.
- [15] ETSI, "Common Air Interface Specification to Be Used for the Interworking Between Cordless Telephone Apparatus in the Frequency Band 864.1 MHz, Including Public Access Services," I-ETS 300 131:1990, June 1991.
- [16] ETSI, "Digital European Cordless Telephone Common Interface," v. 05.03, May 1991.
- [17] L. Lopes, "An Overview of DECT Radio Link Research in COST 231," *IEEE PIMRC '94 Conf. Proc.*, Sept. 21-23, 1994, The Hague, The Netherlands, pp. 99-104.
- [18] R. Jackets, "Performance of DECT for Local Access," *Elect. Lett.*, Feb. 13, 1992, vol. 28, no. 4, pp. 402-4.

- [19] Bellcore, "Personal Communications Services (PCS) Network Access Demand Model and Capacity Analysis," Issue 1, Tech. Rep. SR-INS-002603, Bellcore, Apr. 1993.
- [20] Bellcore, "Bellcore Communications Research Specification of Signaling System Number 7," Issue 2. TR-NWT-000246, 1991.
- [21] Bellcore, "Generic Requirements, Advanced Intelligent Network (AIN) 0.2 Switching Systems," GR-1298-CORE, Nov. 1993.
- [22] Bellcore, "Generic Requirements for WACS Protocols Supporting Wireless Data Services," GR-2850-CORE, Issue 1, Dec. 1994.
- [23] D. J. Harasty *et al.*, "Architecture Alternatives for Wireless Data Services: Interworking with Voiceband Modem," *IEEE NPC '94 Conf. Proc.*, Mar. 16-18, 1994.
- [24] J. C.-I. Chuang, "The Effects of Time Delay Spread on Portable Radio Communications Channels with Digital Modulation," *IEEE JSAC*, vol. SAC-5, June 1987, pp. 879-89.
- [25] D. M. Devasirvatham, "Multipath Time Delay Spread in the Digital Portable Radio Environment," *IEEE Commun. Mag.*, vol. 25, no. 6, June 1987, pp. 13-21.
- [26] S. Rappaport, "Indoor Radio Communications for Factories of the Future," *IEEE Commun. Mag.*, May 1989, pp. 15-24.
- [27] L. B. Lopes, "On the Radio Link Performance of the Digital European Cordless Telecommunications (DECT) System," *IEEE*, pp. 1013-17.
- [28] L. Lopes, "An Overview of DECT Radio Link Research in COST 231," *IEEE PIMRC '94 Conf. Proc.*, Sept. 21-23, 1994, The Hague, The Netherlands, pp. 99-104.
- [29] I. Horikawa and M. Hirono, "A Multi-Carrier Switching TDMA-TDD Microcell Telecommunications System," *IEEE VTC Conf. Proc.*, May 1990, pp. 167-71.
- [30] J. C. Cox, *et al.*, "Universal Digital Portable Communications System Perspective," *IEEE JSAC*, vol. SAC-5, no. 5, May 1987, pp. 764-73.
- [31] J. C.-I. Chuang, "The Effects of Time-Delay Spread on QAM with Non-linearly Switched Filters in a Portable Radio Communications Channel," *Proc. Int'l. Conf. on Digital Land Mobile Radio Comm.*, Venice, Italy, June 3-July 3, 1987, pp. 104-13.
- [32] J. C.-I. Chuang, "Comparison of Coherent and Differential Detection of BPSK and QPSK in a Quasistatic Fading Channel," *IEEE Trans. on Commun.*, May 1990, pp. 565-67.
- [33] D. M. J. Devasirvatham, R. R. Murray and D. Wolter, "Radiowave Propagation Measurements for Residential Fixed Wireless Access Services," submitted to *IEEE Trans. on Vehicular Tech.*
- [34] L. F. Chang and J. C.-I. Chuang, "Outage Probability for a Frequency-Selective Fading Digital Portable Radio Channel with Selection Diversity Using Coding," *IEEE ICC '89*, Boston, MA, June 11-14, 1989, pp. 176-81.
- [35] R. Jackets, "Performance of DECT for Local Access," *Elect. Lett.*, Feb. 13, 1992, vol. 28, no. 4, pp. 402-04.
- [36] J. C.-I. Chuang and N. R. Sollenberger, "Burst Coherent Demodulation with Combined Symbol Timing, Frequency Offset Estimation and Diversity Selection," *IEEE Trans. on Commun.*, July 1991.
- [37] V. K. Varma *et al.*, "Performance of 32 kb/s ADPCM in Frame Erasures," *IEEE VTC '94 Conf. Proc.*, Stockholm, Sweden, June, 1994.
- [38] V. Varma, A. R. Noerpel, and D. J. Harasty, "Integrated Alerting and System Broadcast Channel for a Wireless Access System," *IEEE VT Trans.*, vol. 45, no. 1, Feb. 1996.
- [39] D. J. Harasty and A. R. Noerpel, "Multiplexing Protocol for the WACS System Broadcast Channel," *IEEE - ICUPC '93 Conf. Proc.*, Ottawa, Canada, Oct. 12-15, 1993.
- [40] Y. B. Lin and A. R. Noerpel, "Implicit Deregistration in a PCS Network," *IEEE ICC '94 Proc.*, New Orleans, LA, May 1-5, 1994.
- [41] A. R. Noerpel, Y. B. Lin and L. F. Chang, "PACS Contention Algorithm for Initial Access and Handoff," *Proc. WINLAB Workshop*, East Brunswick, NJ, Apr. 26-27, 1995.
- [42] J. C.-I. Chuang, "Autonomous Adaptive Frequency Assignment of TDMA Portable Radio Systems," *IEEE Trans. Vehicular Tech.*, vol. 40, no. 3, Aug. 1991, pp. 627-35.
- [43] S. McCann and A. P. Croft, "Digital European Cordless Telecommunications System Blind Spot Algorithm Evaluation Results," *IEEE GLOBECOM '90 Conf. Proc.*, 1990, p. 604.5.1.
- [44] Bout, Sparreboom, Brouwer, and Prasad, "A Mathematical Model for Dynamic Channel Selection in Conformity with the Digital European Cordless Telecommunications Standard," *Proc. IEEE PIMRC '93*, Sept. 1993.
- [45] ANSI J-STD-014 Supplement A, "Personal Access Communications System Unlicensed (version A)."
- [46] ANSI J-STD-014 supplement B, "Personal Access Communications System Unlicensed (version B)."
- [47] A. R. Noerpel, L. F. Chang and R. A. Ziegler, "PACS-UB, A Protocol for the Unlicensed Spectrum," *Proc. IEEE ICC '95*, Seattle, WA, June 19-22, 1995.
- [48] A. R. Noerpel, E. Laborde and K. Felix, "PACS-UB for Use in Unlicensed Spectrum," *Proc. First Annual WINForum User PCS Workshop*, Dallas, TX, Oct. 17-19, 1994.
- [49] A. R. Noerpel, Y. B. Lin and L. F. Chang, "Performance Modeling of Polling Deregistration for Unlicensed PCS," *IEEE JSAC*, Special Issue: Wireless Local Communications, vol. 14, no. 4, May 1996.
- [50] S. McCann and A. P. Croft, "Digital European Cordless Telecommunications System Blind Spot Algorithm Evaluation Results," *IEEE*, 1990.
- [51] R. A. Ziegler *et al.*, "Low Complexity Hardware Implementation for Interoperable Licensed & Unlicensed Personal Communications Services: the PACS-UB System," *Proc. WINLAB Workshop*, East Brunswick, NJ, Apr. 26-27, 1995.
- [52] D. J. Harasty and A. R. Noerpel, "Multiplexing Protocol for the WACS System Broadcast Channel," *Proc. IEEE ICUPC '93*, Ottawa, Canada, Oct. 12-15, 1993.
- [53] D. Akerberg, "Properties of a TDMA Pico Cellular Office Communication System," *IEEE Conf. Proc. 1988*, p. 41.4.1.
- [54] D. M. J. Devasirvatham, "Multi-Frequency Propagation Measurements and Models in a Large Metropolitan Commercial Building for Personal Communications," *IEEE PIMRC '91 Conf. Proc.*, London, U.K., 1991.
- [55] R. C. Bernhardt, "User Access in Portable Radio Systems in a Co-Channel Interference Environment," *IEEE JSAC*, vol. 7, no. 1, 1989, pp. 49-58.
- [56] Radio Advisory Board of Canada, "CT2Plus class 2: Specification for the Canadian Common Air Interface for Digital Cordless Telephony, Including Public Access Services, Annex 1 to Radio Standards Specification 130," 1992.
- [57] M. Mouly and M.-B. Pautet, *The GSM System for Mobile Communications*, M Mouly, 49 rue Louise Bruneau, Palaiseau, France, 1992.
- [58] EIA/TIA, "Cellular Radio-Telecommunications Intersystem Operations: Intersystem Handoff," Tech. Rep. IS-41.2-B, EIA/TIA, 1991.
- [59] EIA/TIA, "Cellular Radio-Telecommunications Intersystem Operations: Automatic Roaming," Tech. Rep. IS-41.3-B, EIA/TIA, 1991.
- [60] C. N. Lo, R. S. Wolff, and R. C. Bernhardt, "Expected Network Database Transaction Volume to Support Personal Communication Services," *Proc. First Int'l. Conf. on Universal Pers. Commun.*, Dallas, TX, 1992.
- [61] P. Porter, D. Harasty, M. Beller, A. Noerpel and V. Varma, "The Terminal Registration/Deregistration Protocol for Personal Communication Systems," *Proc. Wireless '93*, July 1993.
- [62] Y.-B. Lin and A. Noerpel, "Implicit Deregistration in a PCS Network," *IEEE Trans. Vehicular Tech.*, Dec. 1994.
- [63] M. J. Beller and Y. Yacobi, "Fully-Fledged Public-Key Authentication and Key Agreement for Low-Cost Terminals," *Elect. Lett.*, vol. 29, no. 11, 1993.
- [64] TIA/EIA Telecommunications Systems Bulletin (TSB-51), "Cellular Radio Telecommunications Intersystem Operations: Authentication, Signalling Message Encryption and Voice Privacy," May 1993.
- [65] NBS, "Data Encryption Standard," Tech. Rep. FIPS-PUB-45, National Bureau of Standards, 1977.

Biographies

ANTHONY NOERPEL received the M.S.E.E. from New Jersey Institute of Technology in 1977 and the B.A. in mathematics from Rutgers University in 1972. Between June 1977 and December 1983, he worked for Bell Telephone Laboratories on communications satellite system engineering and antenna analysis and design. Between January 1984 and August 1995, he worked for Bellcore on point-to-point microwave radio, antennas and propagation, and personal communications and wireless access. He authored the Bellcore Technical Advisory (TA-NWT-1313) describing the architecture and signaling protocol for the PCS common air interface which has become the ANSI standard Personal Access Communications System (PACS). Since August 1995, he has been working for Hughes Network Systems on wireless access and satellite communications.

YI-BING LIN received his B.S.E.E. degree from National Cheng Kung University in 1983, and his Ph.D. degree in computer science from the University of Washington in 1990. Between 1990 and 1995, he was with the Applied Research Area at Bell Communications Research (Bellcore), Morristown, New Jersey. In 1995, he was appointed full professor of the Department of Computer Science and Information Engineering, National Chiao Tung University. His current research interests include design and analysis of personal communications services network, mobile computing, distributed simulation, and performance modeling. He is an associate editor of the *ACM Transactions on Modeling and Computer Simulation*, a subject area editor of the *Journal of Parallel and Distributed Computing*, an associate editor of the *International Journal in Computer Simulation*, and an associate editor of *SIMULATION* magazine.

HOWARD SHERRY is a chief scientist and director in the Wireless Research Department at Bellcore, where he is responsible for architecture, mobility management, economic assessment, and protocol definition efforts associated with wide area wireless access networks. He has been active in PCS standardization efforts in the United States since their inception. He served on the executive committee that organized and conducted the Joint Experts Meeting on PCS air interface standards and has chaired several of the ad hoc committees in the Joint Technical Committee on Wireless Access standards. He has a Ph.D. and M.S. in electrical engineering from the University of Pennsylvania and a B.S. in electrical engineering from Worcester Polytechnic Institute.