



(19) **United States**

(12) **Patent Application Publication**
CHEN et al.

(10) **Pub. No.: US 2015/0219893 A1**

(43) **Pub. Date: Aug. 6, 2015**

(54) **OPTICAL SYSTEM AND ITS DISPLAY SYSTEM**

G02B 5/09 (2006.01)

G02B 3/00 (2006.01)

G02B 3/02 (2006.01)

(71) Applicants: **LIQXTAL TECHNOLOGY INC.**,
Tainan City (TW); **National Chiao Tung University**,
Hsinchu City (TW)

(52) **U.S. Cl.**
CPC *G02B 27/0025* (2013.01); *G02B 3/0087*
(2013.01); *G02B 3/02* (2013.01); *G02B 5/09*
(2013.01); *G02B 5/3016* (2013.01)

(72) Inventors: **Hung-Shan CHEN**, Taichung City
(TW); **Yi-Hsin LIN**, Zhubei City (TW)

(21) Appl. No.: **14/689,919**

(57) **ABSTRACT**

(22) Filed: **Apr. 17, 2015**

Related U.S. Application Data

(63) Continuation-in-part of application No. 13/828,723,
filed on Mar. 14, 2013.

Foreign Application Priority Data

Feb. 7, 2013 (TW) 102104728

Publication Classification

(51) **Int. Cl.**
G02B 27/00 (2006.01)
G02B 5/30 (2006.01)

An optical system for aberration compensation comprising an optical module and an asymmetric refractive index distribution film is disclosed. The asymmetric refractive index distribution film comprises a liquid crystal and a liquid crystalline polymer, wherein the asymmetric refractive index distribution film set on an out-light surface or an in-light surface of the optical module. A display system comprising the above-mentioned optical system and an image panel are also disclosed herein. The asymmetric refractive index distribution film of the present invention has non-uniform refractive index distribution so as to effectively compensate the aberration formed by the optical module.

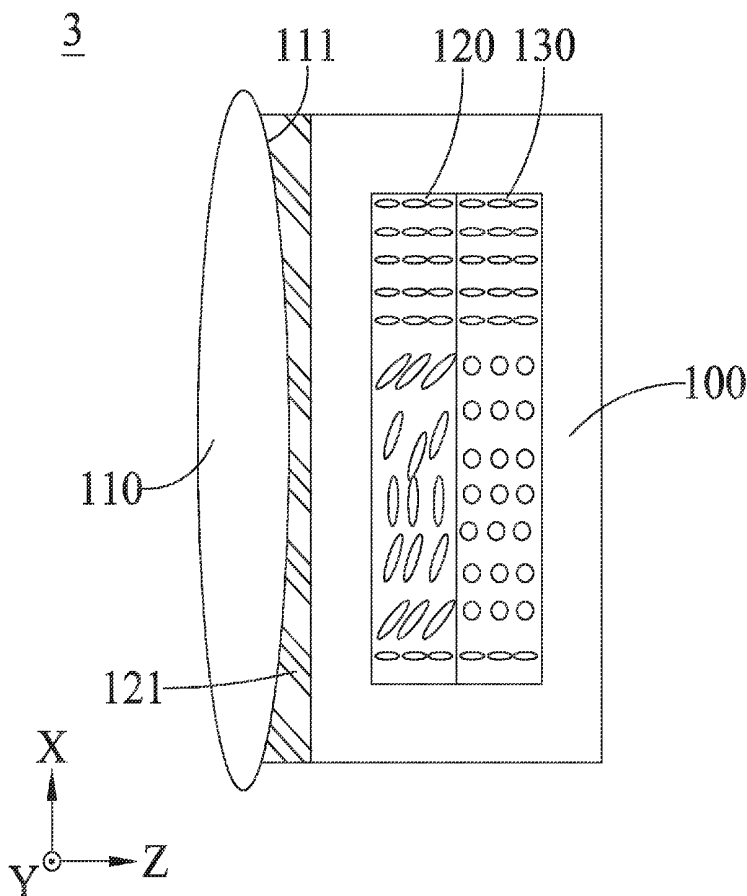

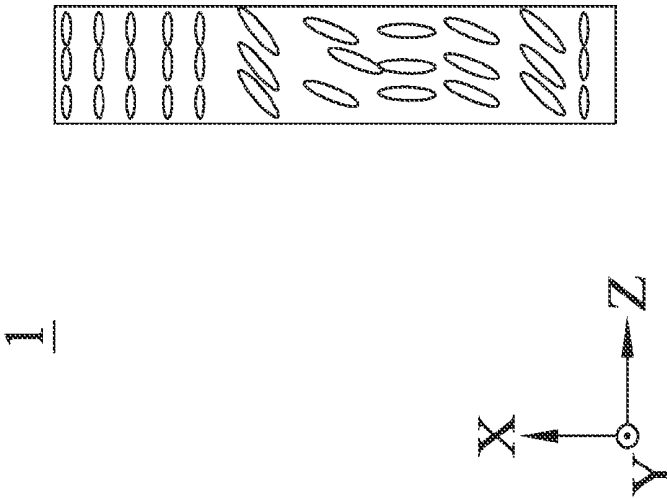

FIG. 1

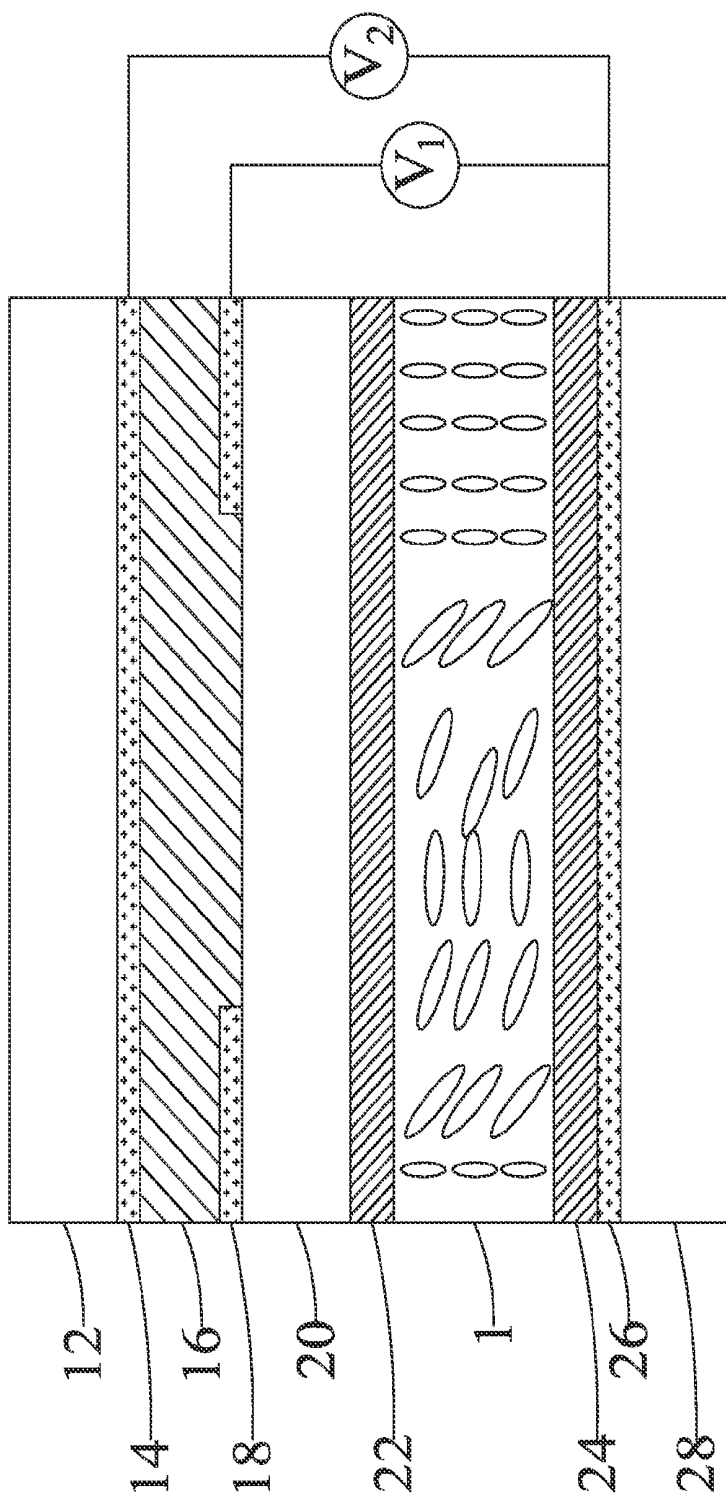

FIG. 2

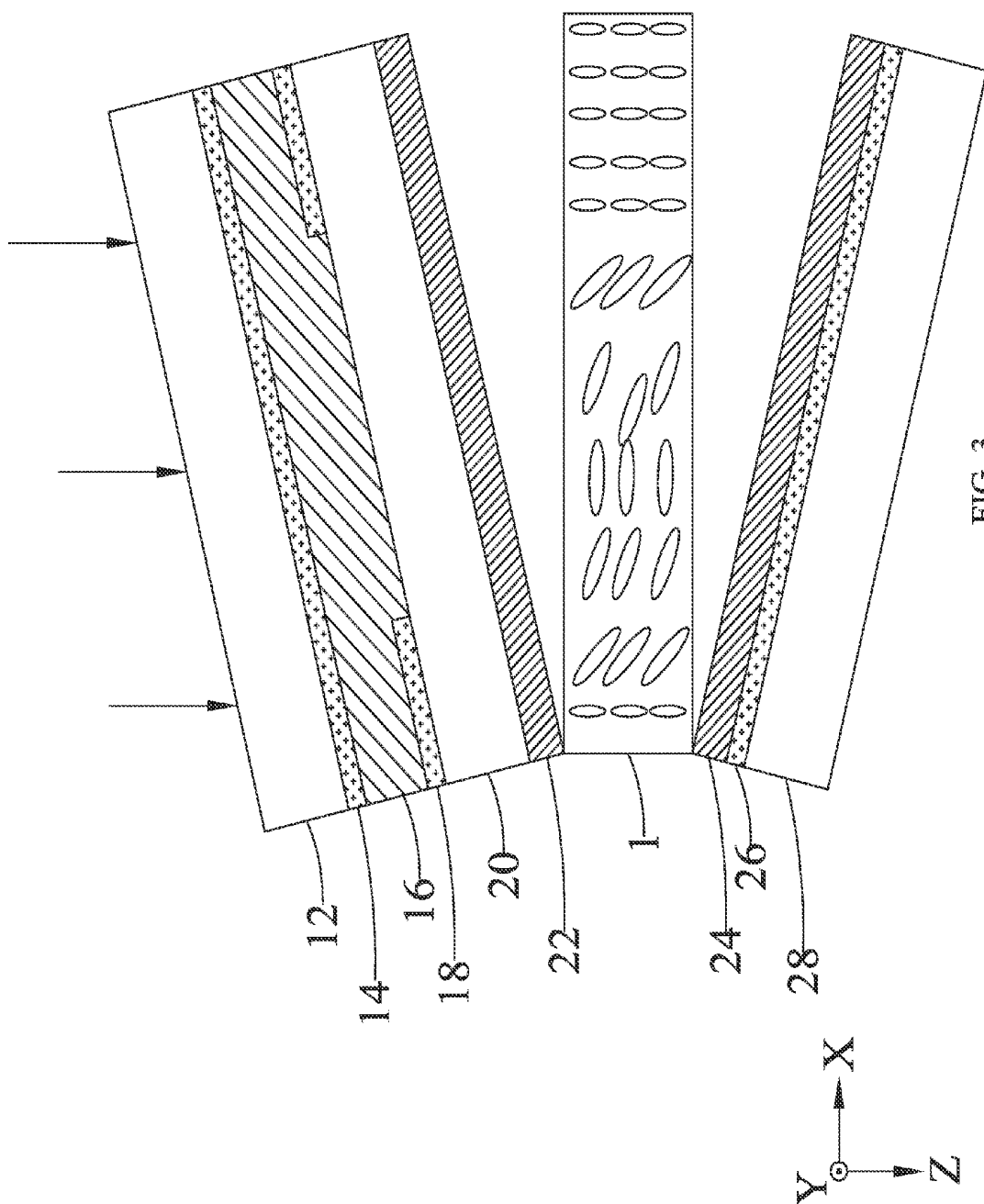

FIG. 3

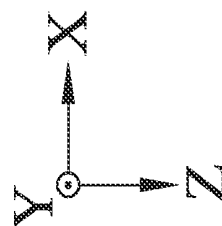
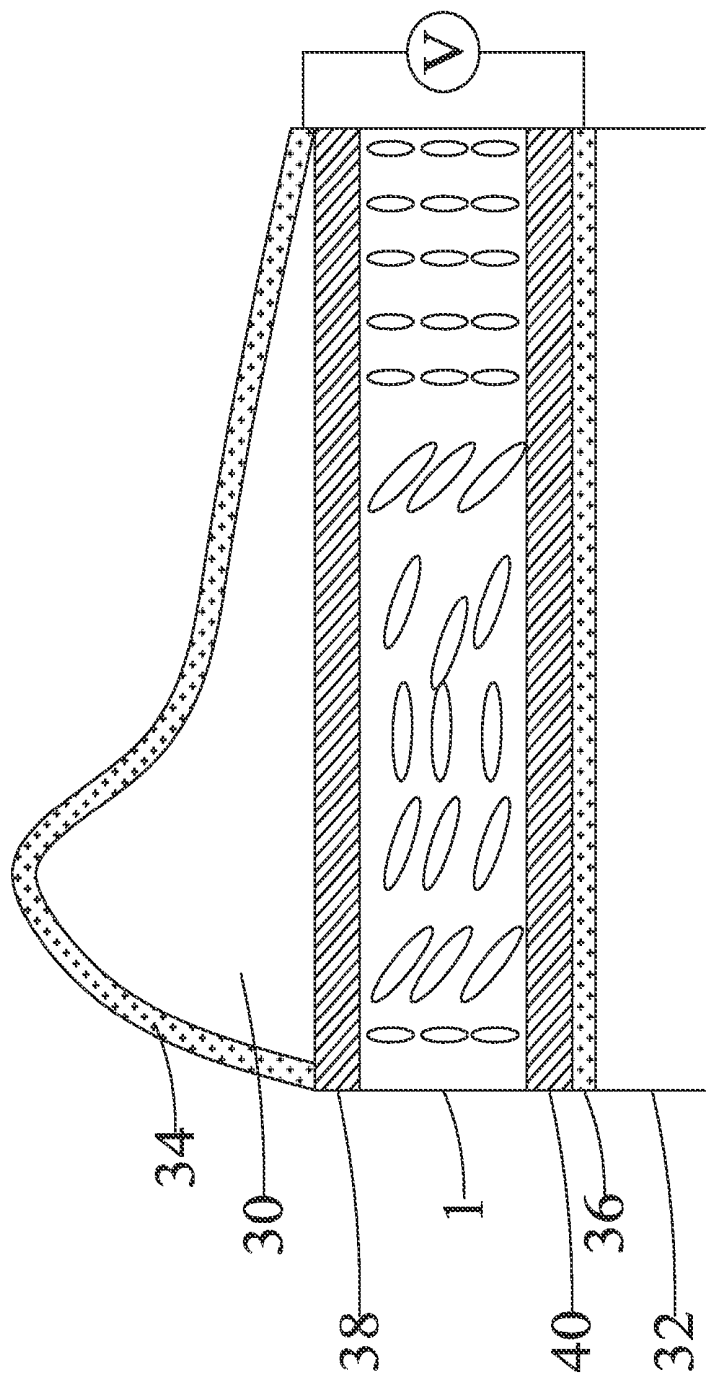

FIG. 4

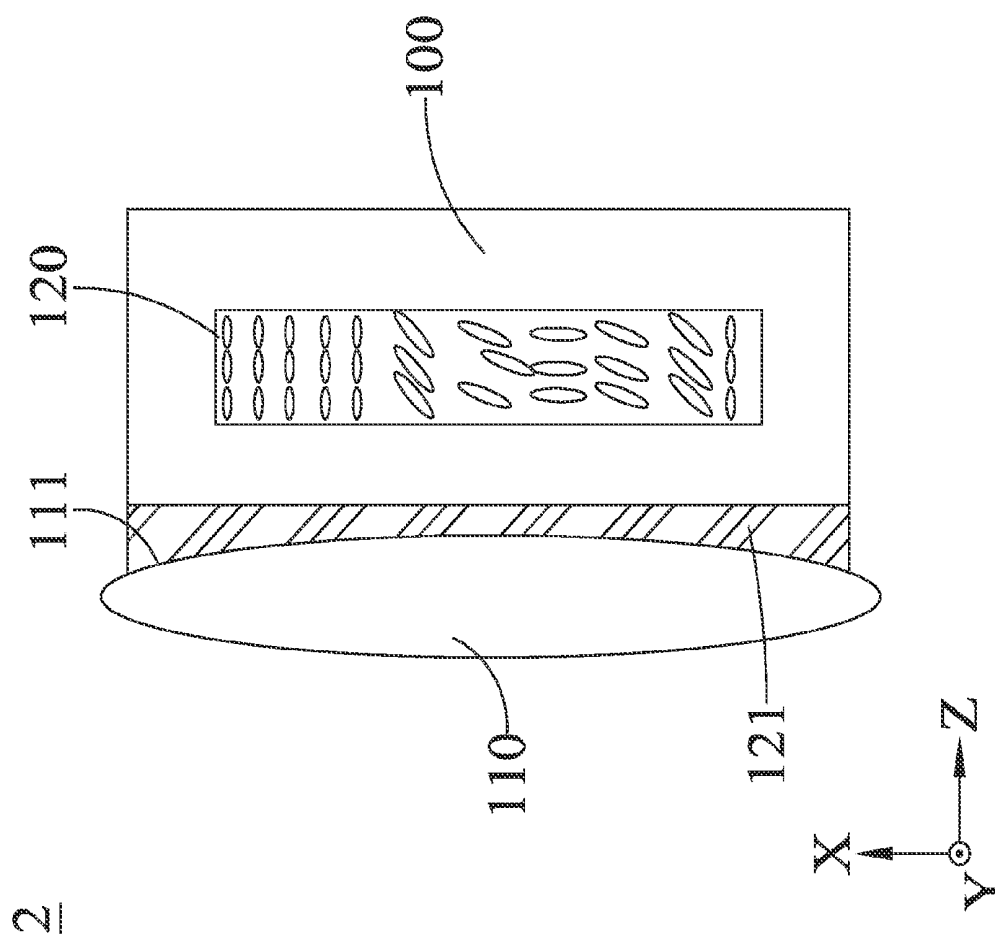

FIG. 5

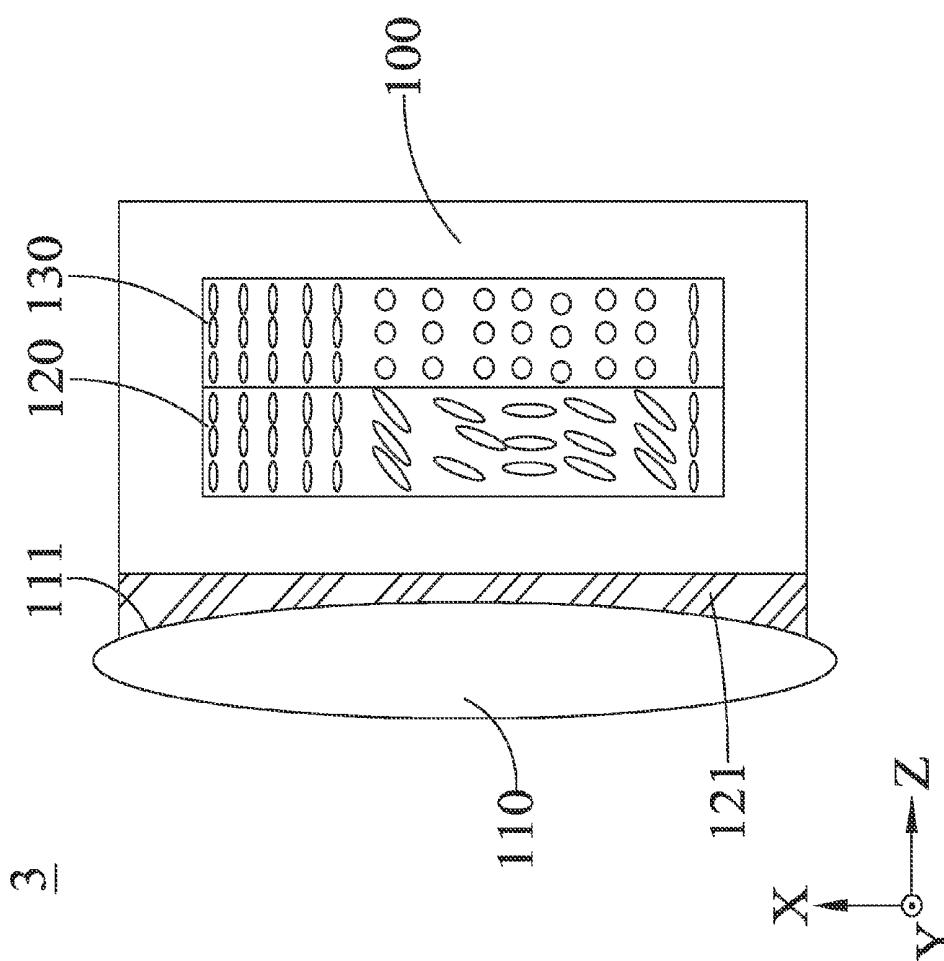

FIG. 6

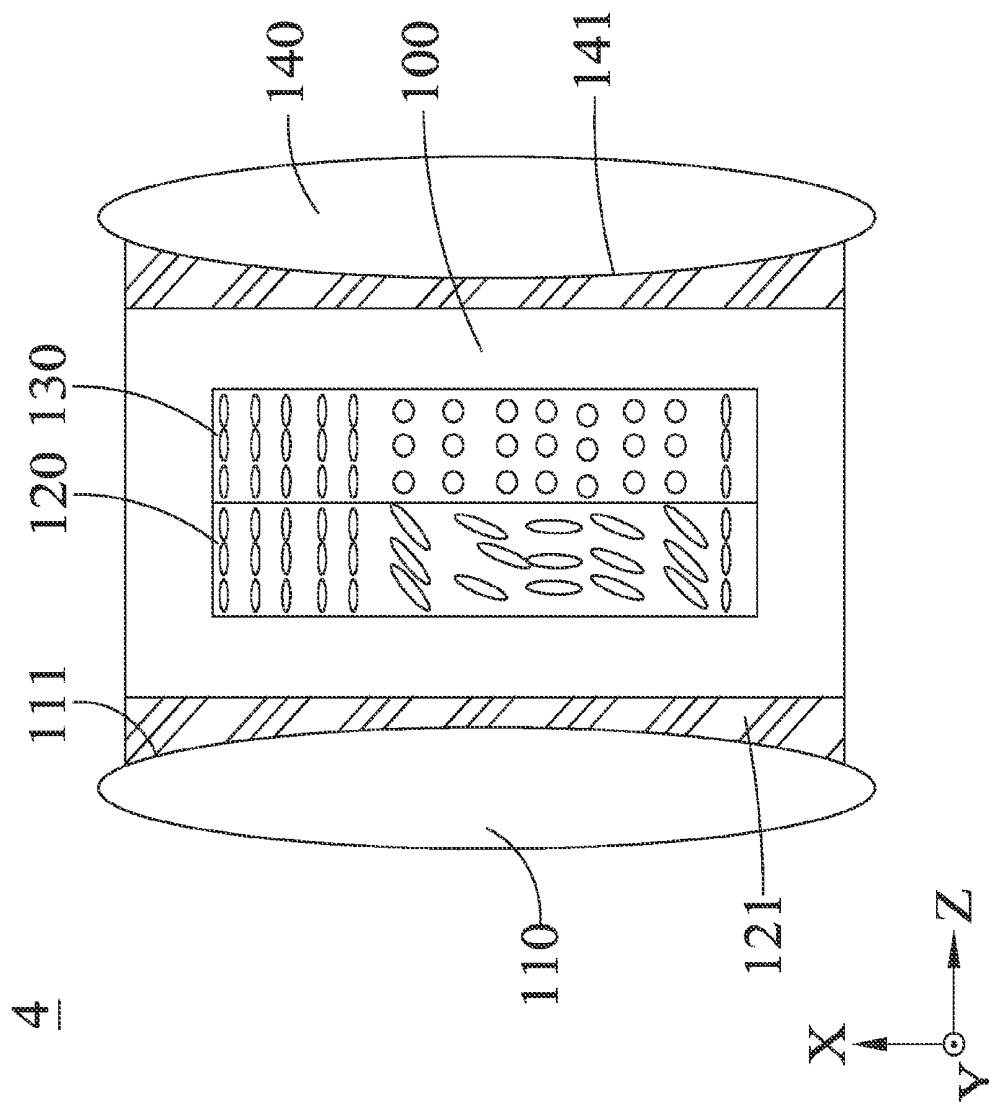

FIG. 7

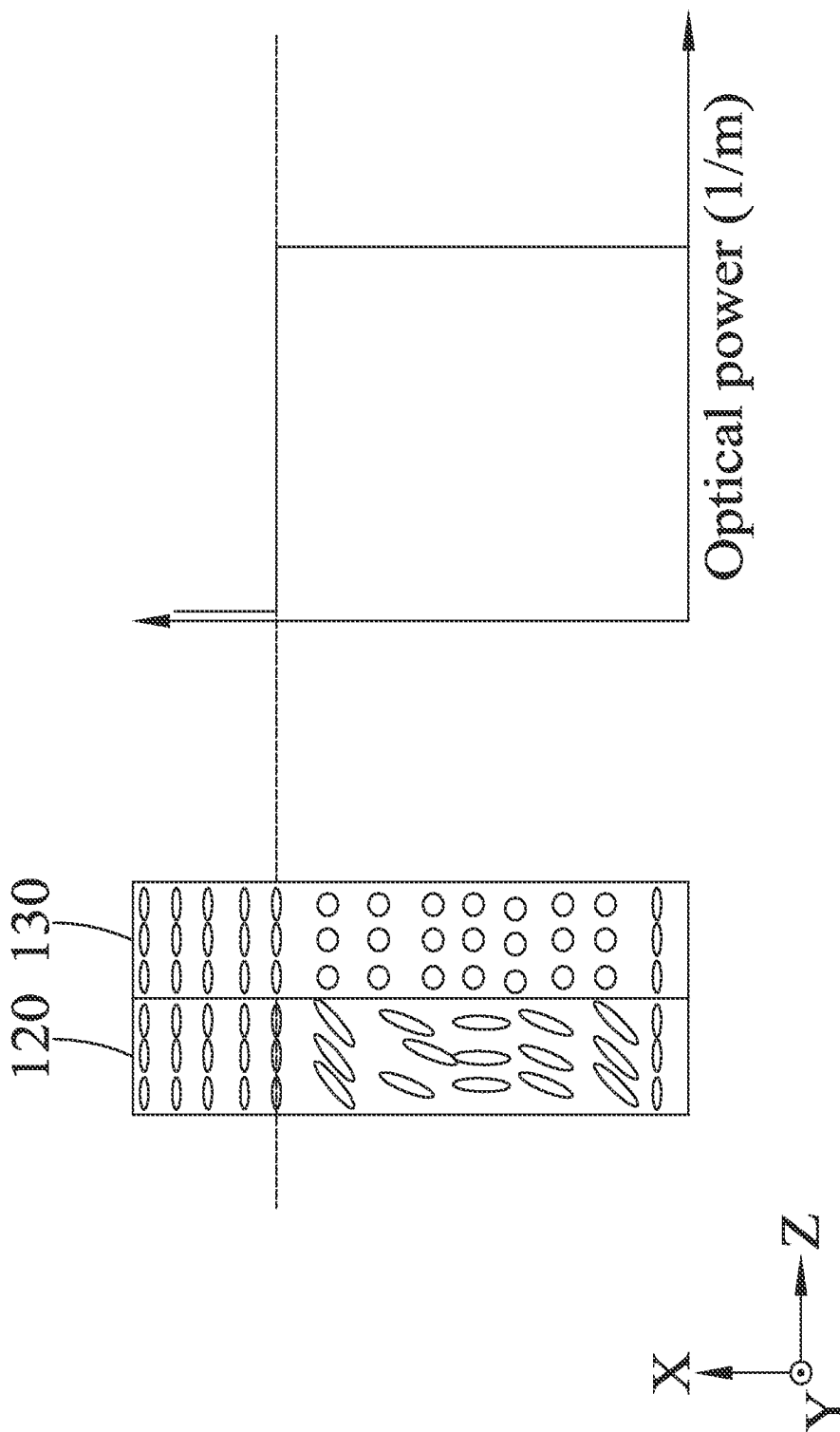

FIG. 8

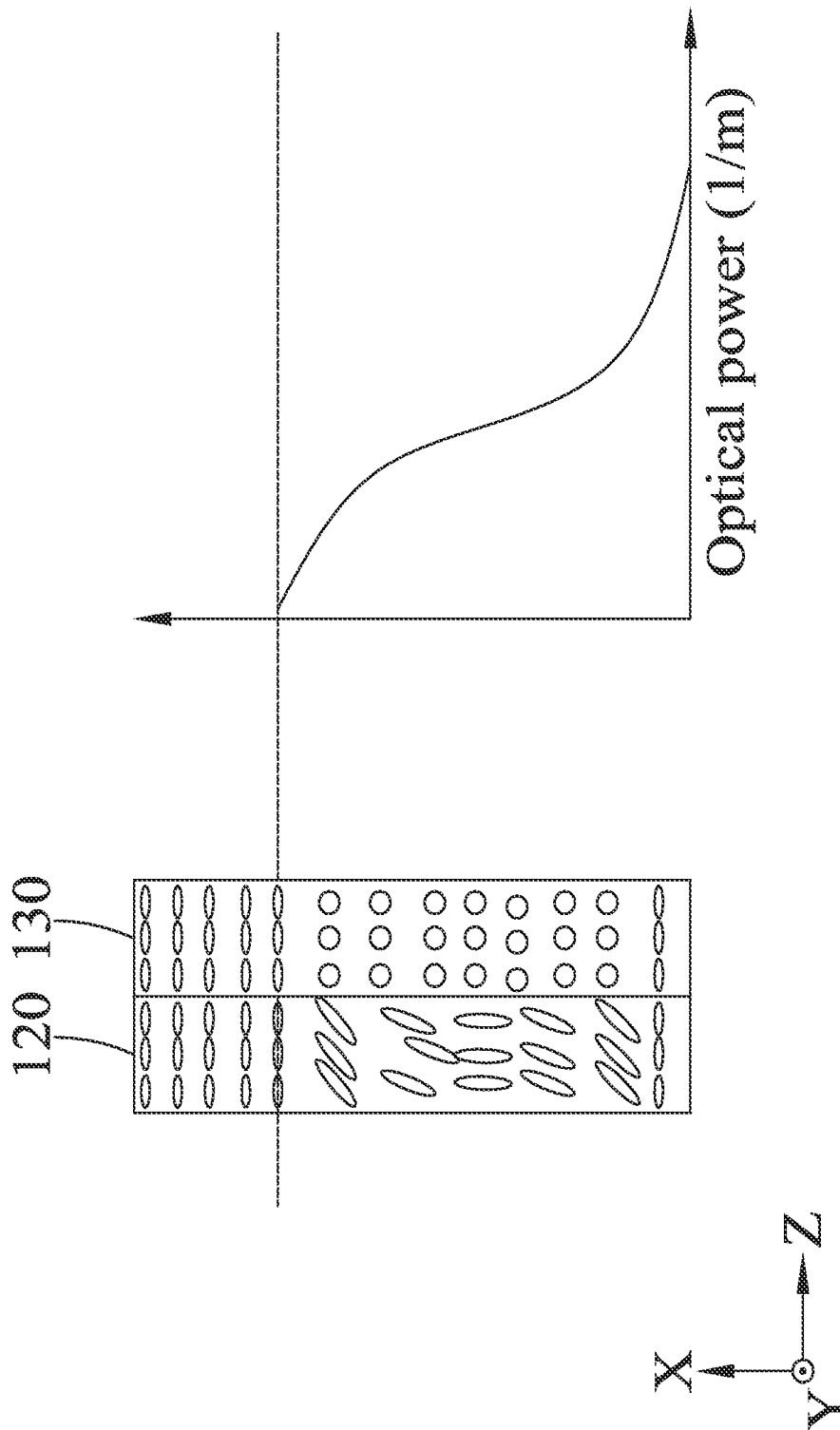

FIG. 9

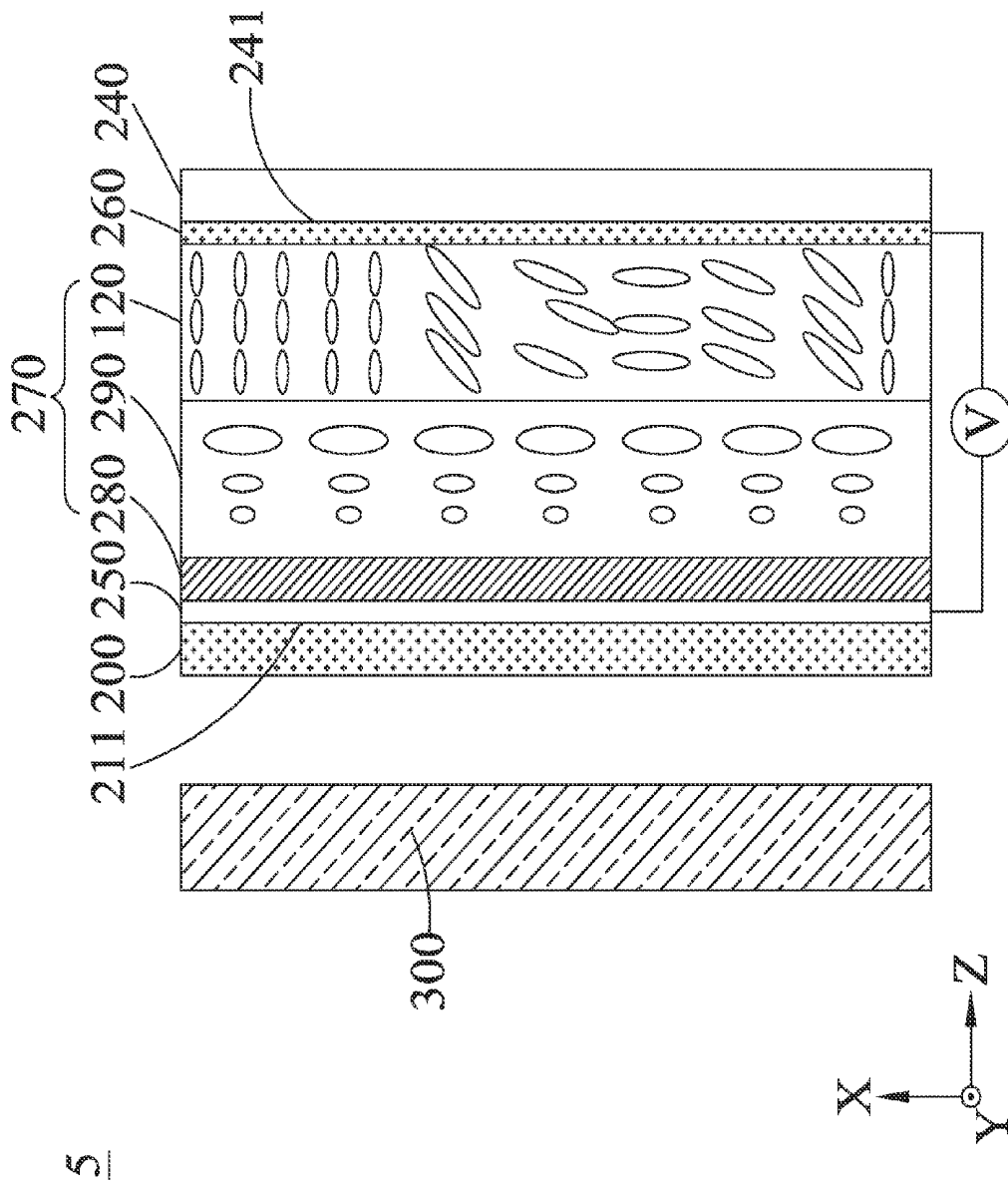

FIG. 10

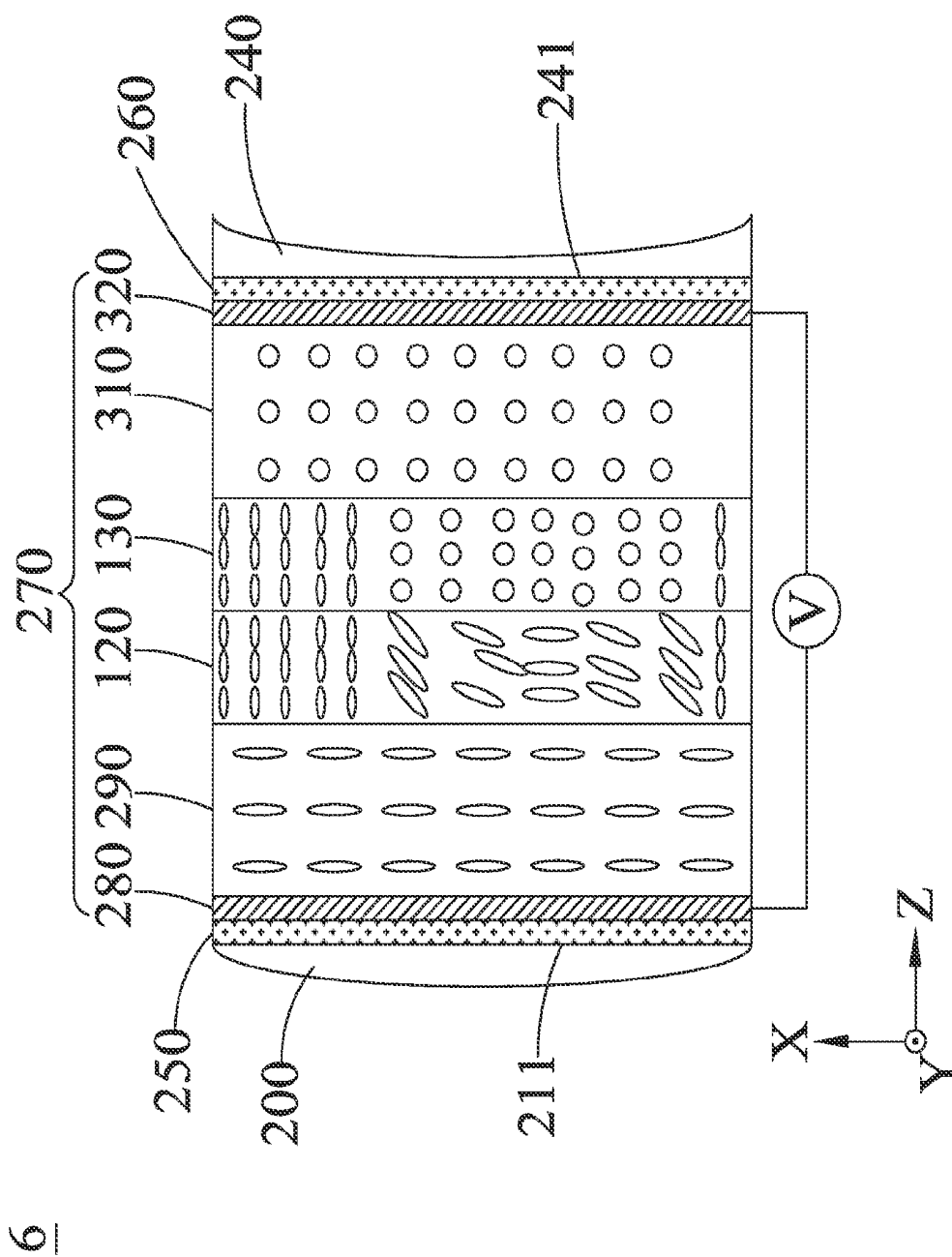

FIG. 11

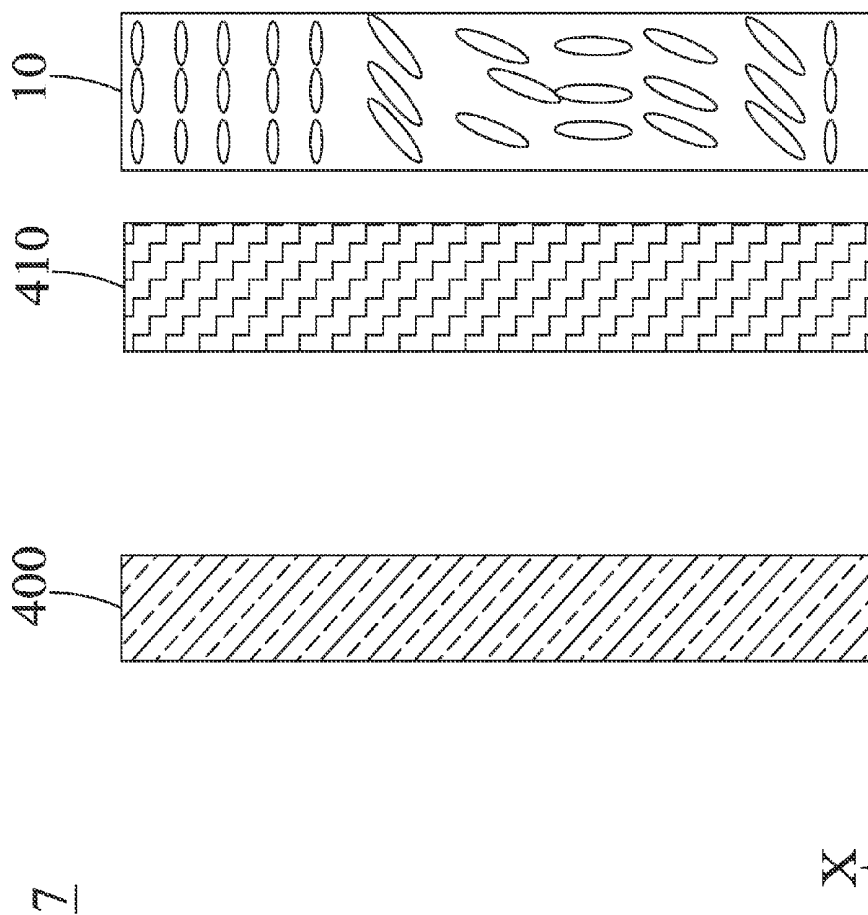

FIG. 12

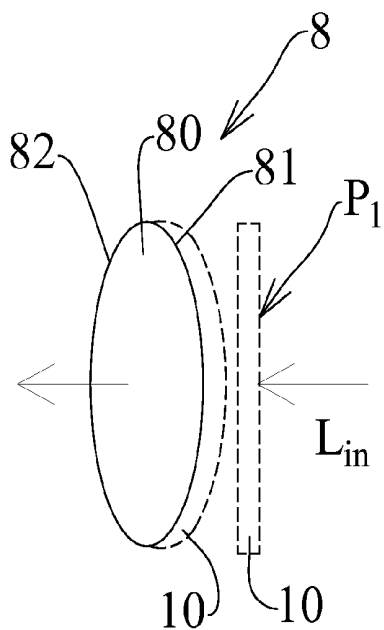

FIG. 13A

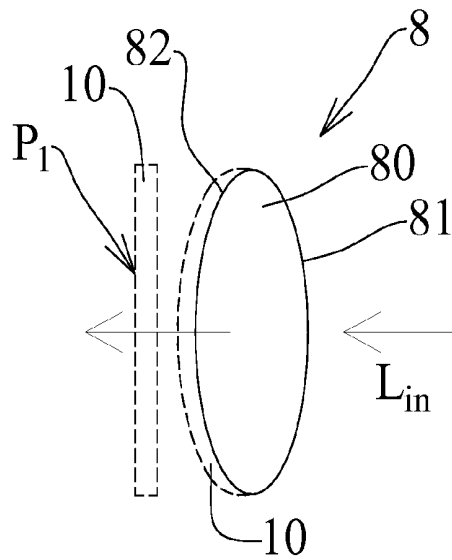

FIG. 13B

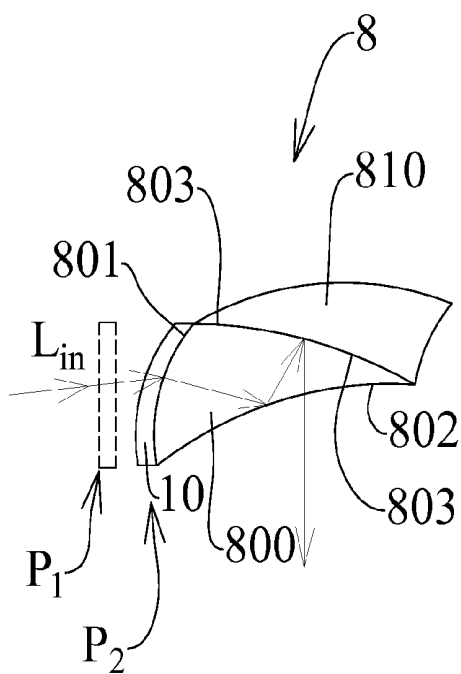

FIG. 14A

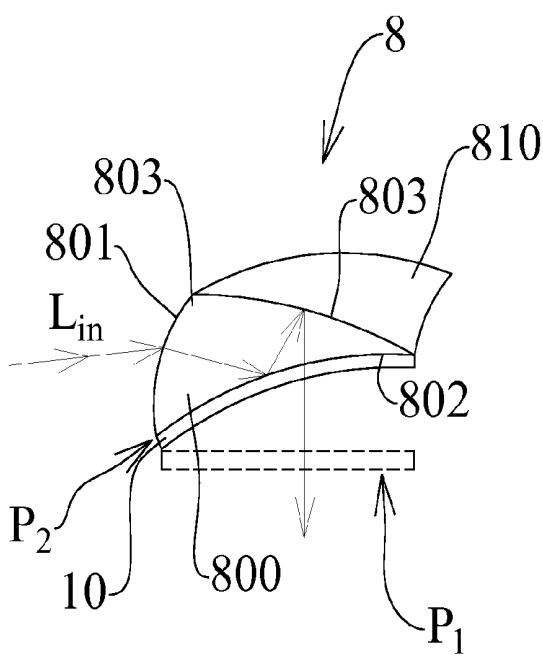

FIG. 14B

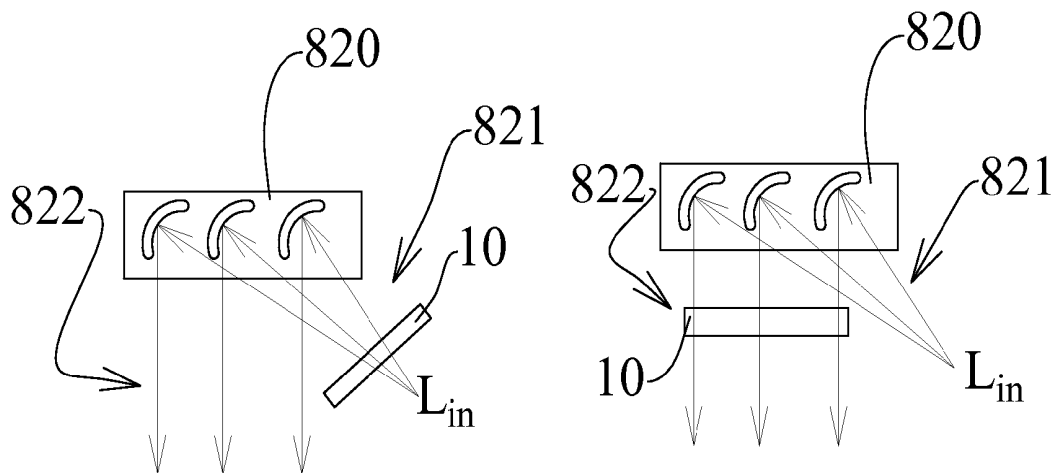

FIG. 15A

FIG. 15B

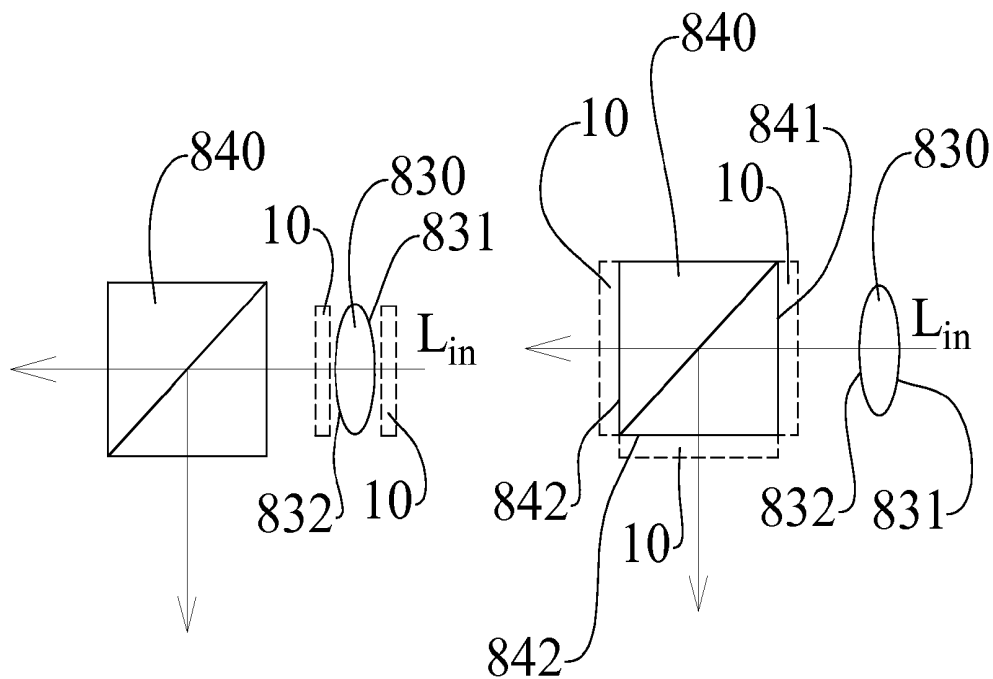

FIG. 16A

FIG. 16B

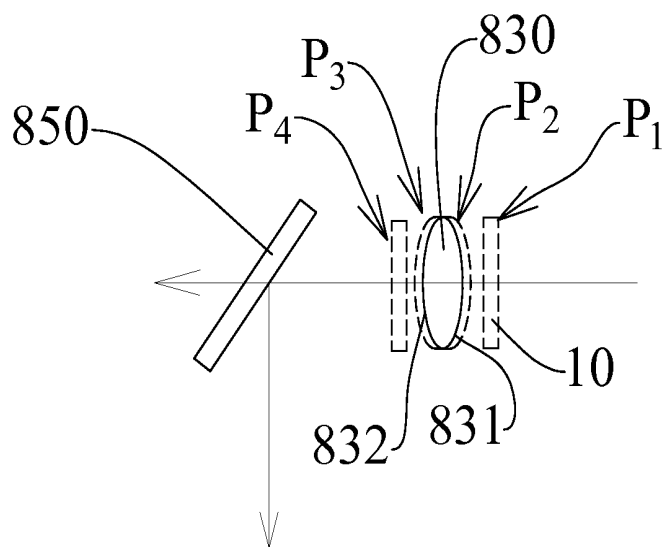

FIG. 17A

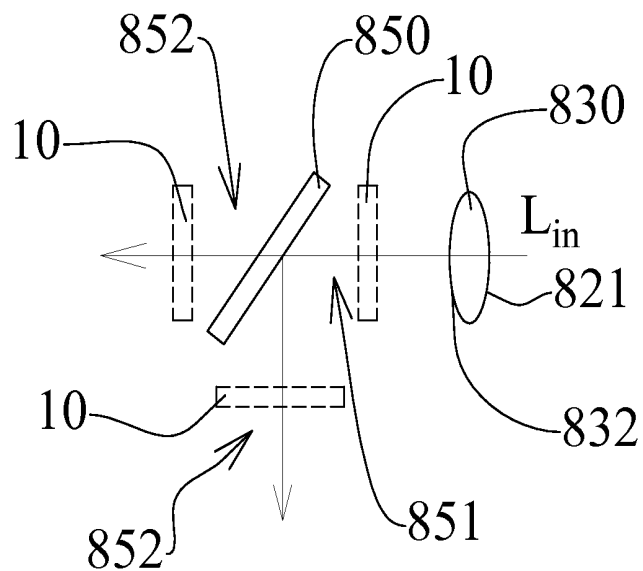

FIG. 17B

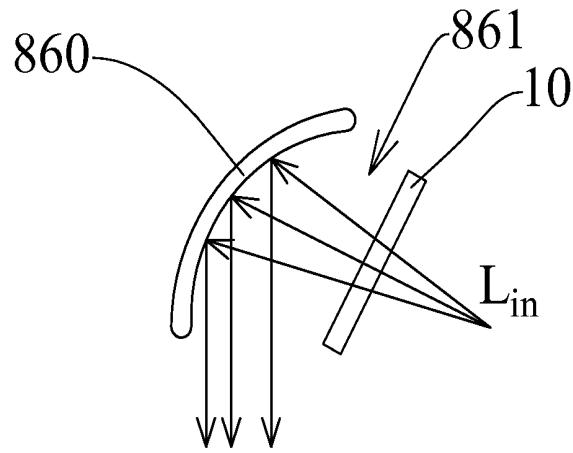

FIG. 18A

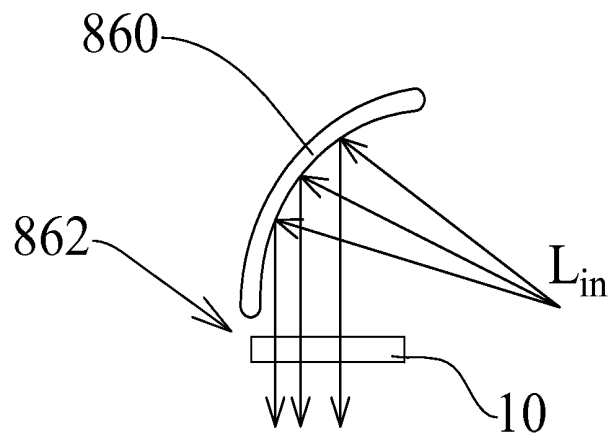

FIG. 18B

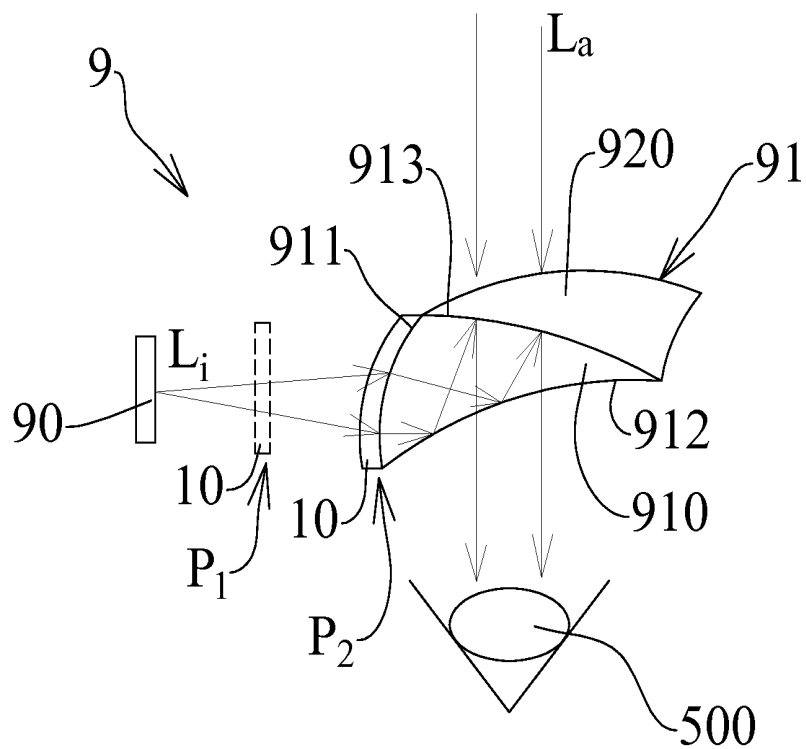

FIG.19A

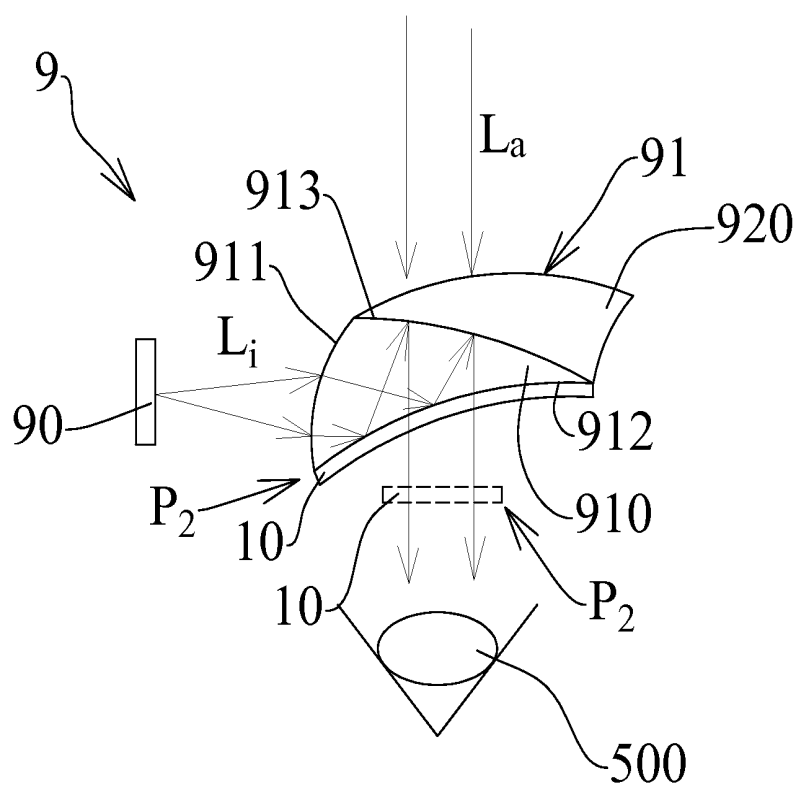

FIG.19B

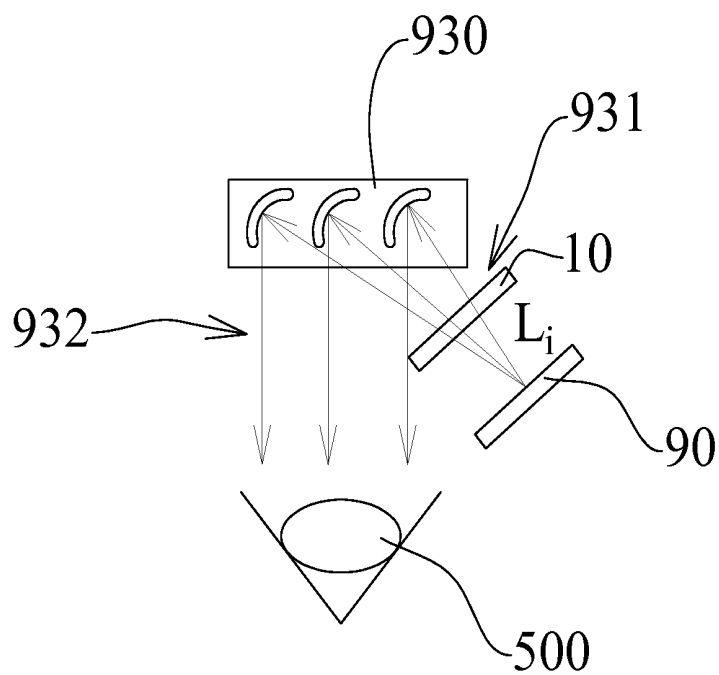

FIG. 20A

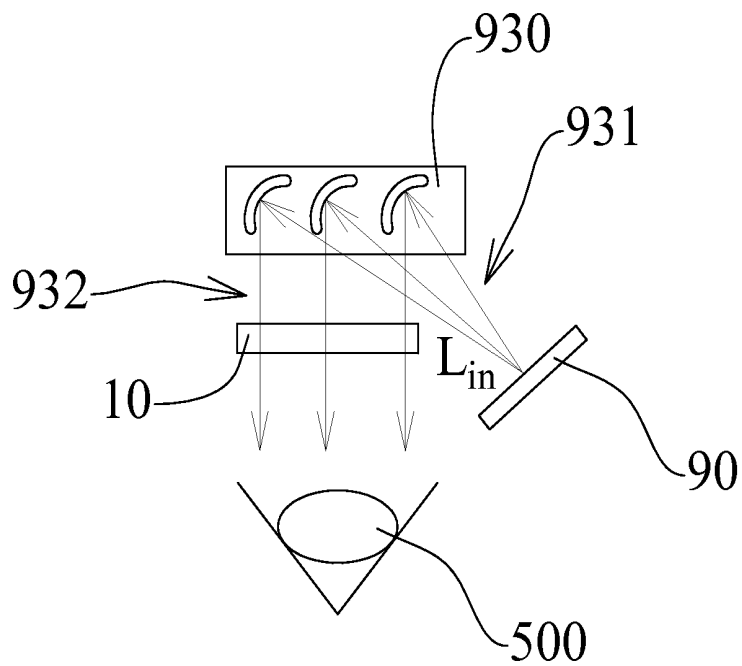

FIG. 20B

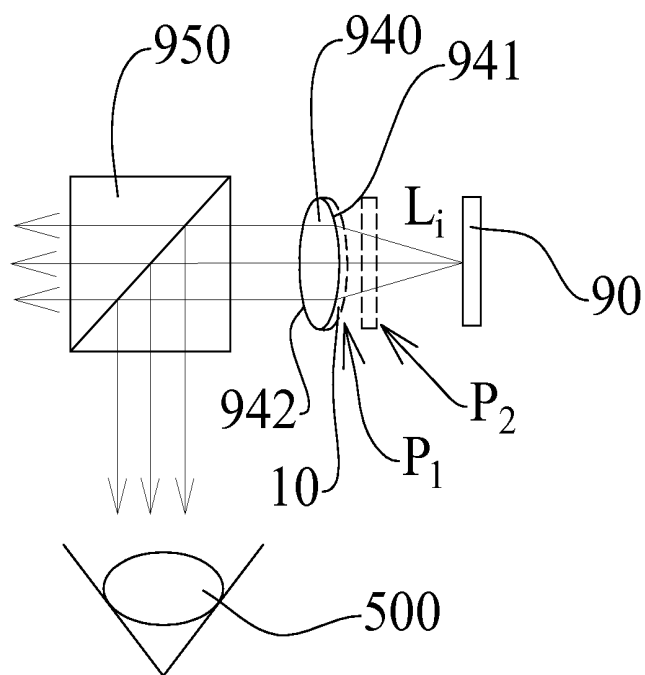

FIG.21A

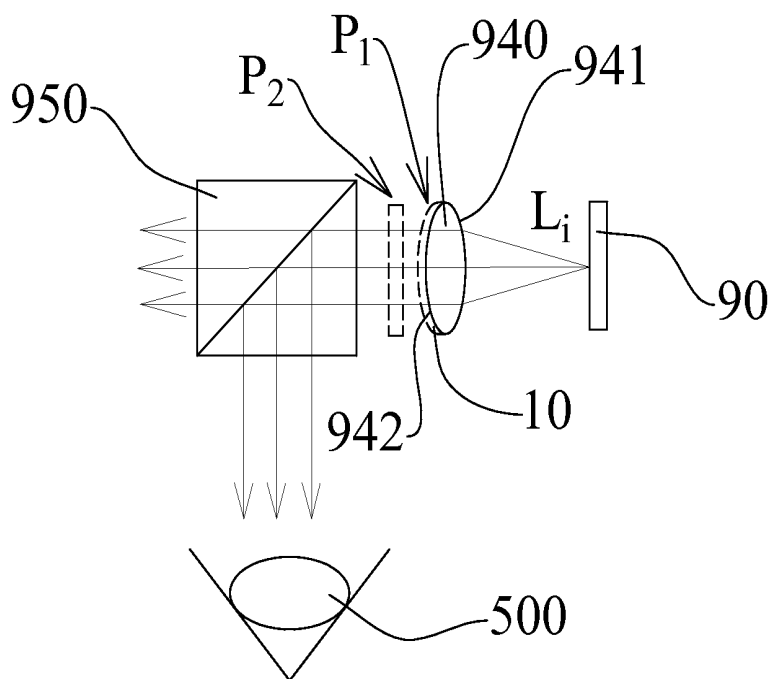

FIG.21B

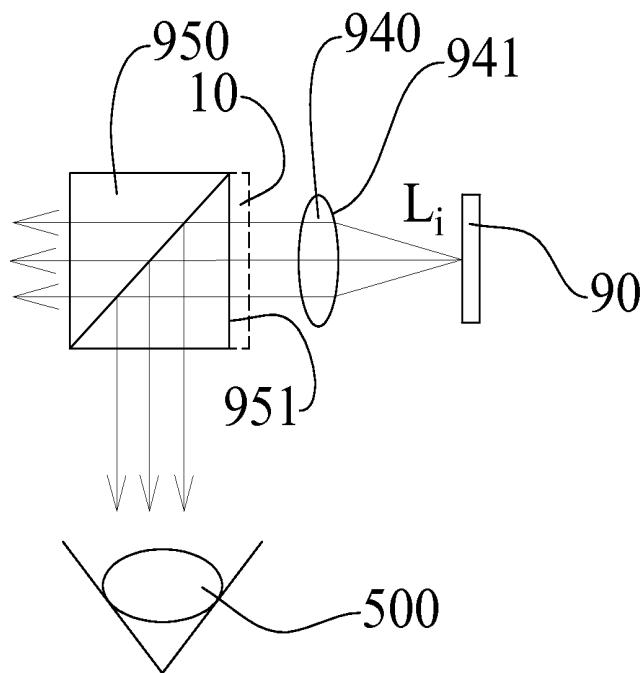

FIG.21C

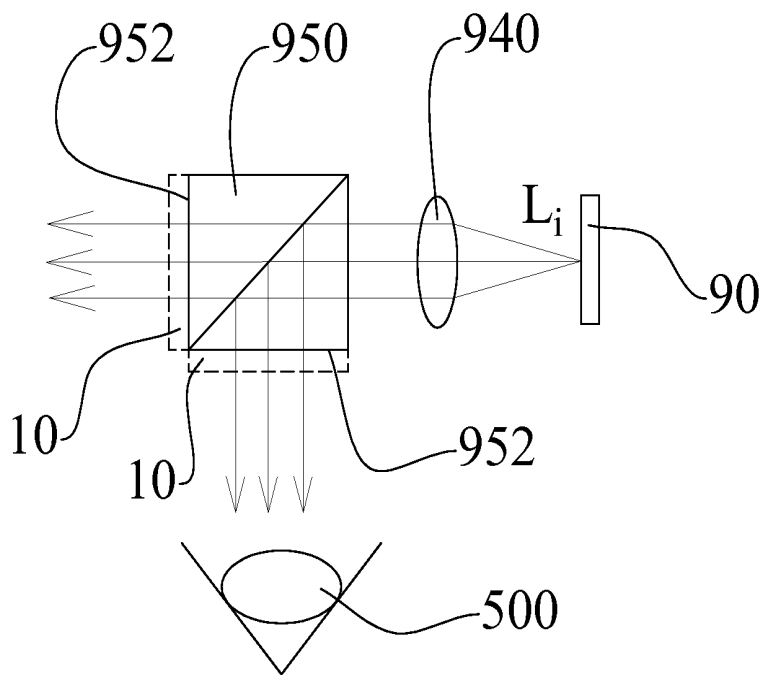

FIG.21D

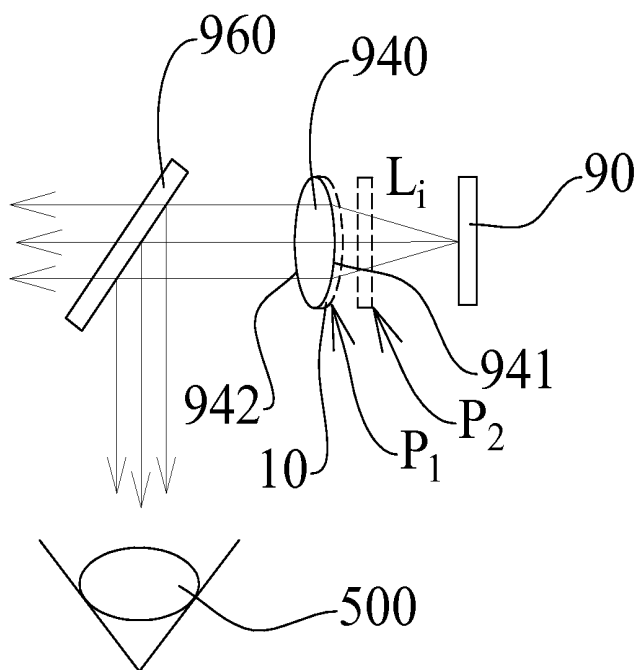

FIG. 22A

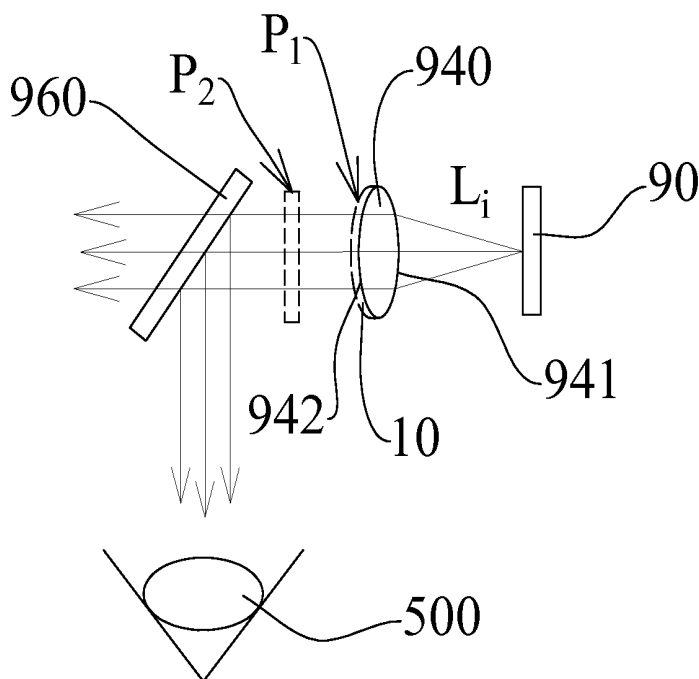

FIG. 22B

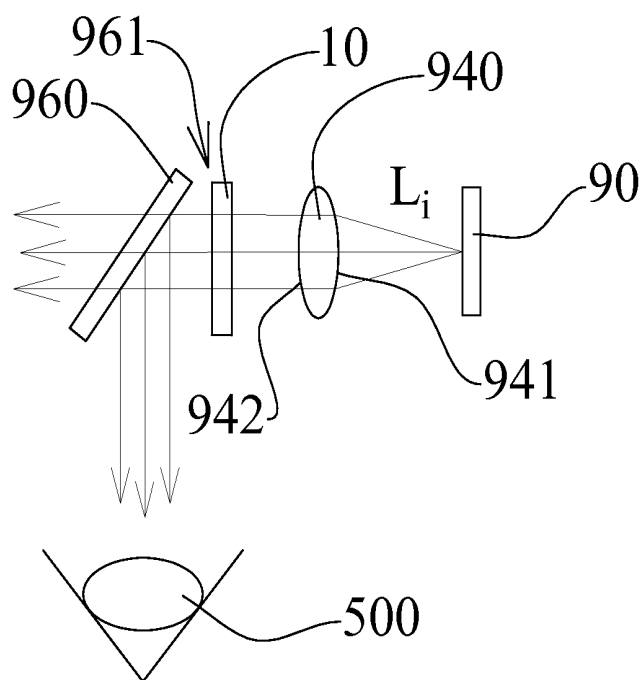

FIG. 22C

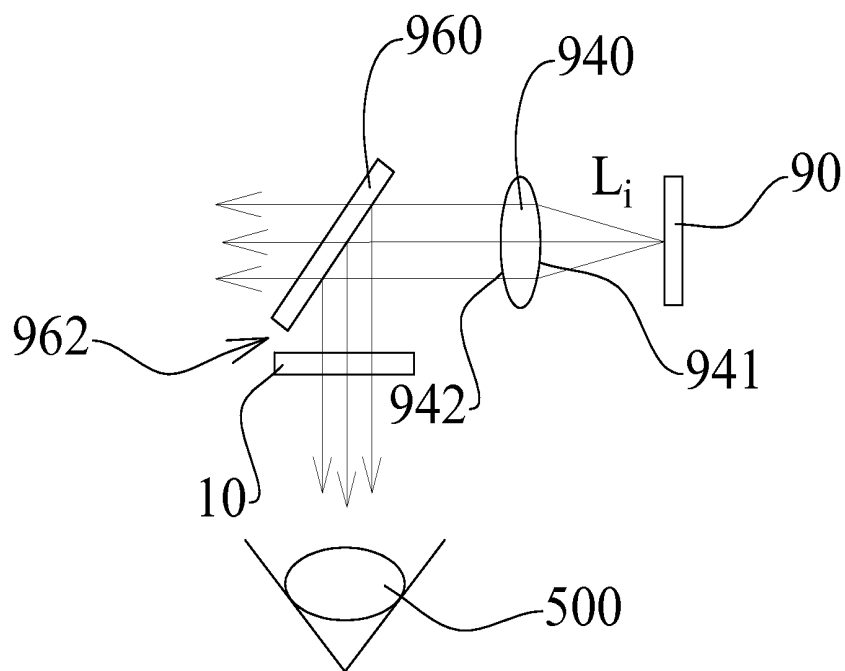

FIG. 22D

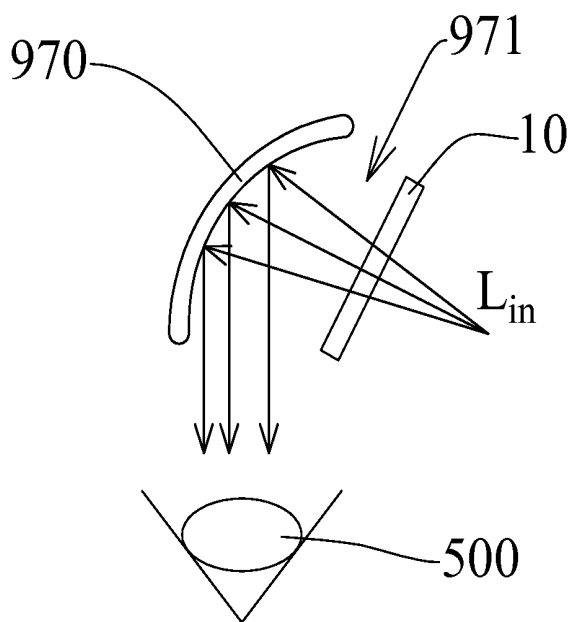

FIG.23A

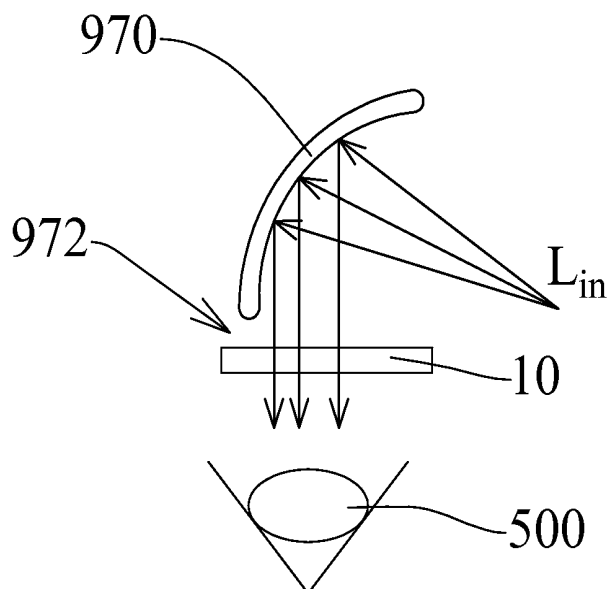

FIG.23B

OPTICAL SYSTEM AND ITS DISPLAY SYSTEM

CROSS-REFERENCE TO RELATED APPLICATION

[0001] This is a continuation-in-part of application Ser. No. 13/828,723, filed in Mar. 14, 2013.

FIELD OF THE INVENTION

[0002] The present invention relates to an optical system, and more particularly to an optical system and a display system having a refractive index distribution film with non-uniform refractive index distribution.

BACKGROUND OF THE INVENTION

[0003] In general, the principle of designing a lens is to let a traveling light produce an optical path difference (thickness*refractive-index). Since the conventional spherical lens has a thickness increases with the optical power, therefore an improved method uses a Fresnel lens to divide the thickness into a smaller periodical structure was proposed. But the manufacture of the mold for the Fresnel lens is very complicated and relatively difficult, and the optical performance has the issues of a high chromatic dispersion and low diffraction efficiency. Therefore, conventional flat lenses such as glasses lenses achieve a change of the optical path difference by changing the refractive index distribution.

[0004] Wherein, the liquid crystalline polymer has the unique birefringence feature, and thus it can be used for the design of a flat lens. Since the liquid crystalline polymer also has the properties of dielectric anisotropy, therefore the electric field distribution can be applied to manufacture an electrically tunable liquid crystal lens. However, the present liquid crystalline polymer film only has the same refractive index distribution. In other words, each position of the liquid crystalline polymer film has the same focal length. Therefore, the present liquid crystalline polymer film with the design of a single focal length cannot be used freely with other lens. Due to the liquid crystalline polymer film having the design of a single focal length, additional components are required to change the refractive index distribution of the liquid crystal lens for manufacturing the electrically controlled liquid crystal lens.

SUMMARY OF THE INVENTION

[0005] The present invention is directed to an optical system and its display system, the asymmetric refractive index distribution film having multi-segment or gradual variation of optical power is utilized to effectively compensate the aberration formed by the optical module.

[0006] To achieve the aforementioned objective, the present invention provides an optical system with an aberration compensation function comprises an optical module and a refractive index distribution film. The optical module has a curved surface. The refractive index distribution film comprises a liquid crystal and a liquid crystalline polymer, wherein a refractive index distribution of the refractive index distribution film is asymmetric and the tilt angle of the liquid crystal of the refractive index distribution film is fixed; the refractive index distribution film is arranged on a first side or a second side of the optical module; and the refractive index distribution film is utilized to compensate the aberration generated by the optical module.

[0007] To achieve another objective, the present invention further provides a display system with an aberration compensation function comprises an optical system and an image panel. The optical system comprises a refractive index distribution film and an optical module. The refractive index distribution film comprises a liquid crystal and a liquid crystalline polymer, wherein a refractive index distribution of the refractive index distribution film is asymmetric and the tilt angle of the liquid crystal of the refractive index distribution film is fixed; the refractive index distribution film is arranged on a first side or a second side of the optical module; and the refractive index distribution film is utilized to compensate the aberration generated by the optical module. The image panel is utilized for displaying an image, wherein the image panel set on a light entrance side of the optical system, and the image light projected from the image panel passes through the optical system to a viewer's eyes.

[0008] In summation, the liquid crystalline polymer lens structure of the present invention has one or more of the following advantages:

[0009] (1) The liquid crystalline polymer film of the present invention is flexible, so that it can be used together with the lens as a simple lens sticker.

[0010] (2) The liquid crystalline polymer film of the present invention with a non-uniform refractive index distribution has the effect of correcting nearsightedness, farsightedness, presbyopia, parallax and compensating the aberration.

[0011] (3) The liquid crystalline polymer film of the present invention has a non-uniform refractive index distribution and after finishing the production, the tilt angle of the liquid crystal of the refractive index distribution film is fixed. Due to no additional electrically-controlled component is needed, the cost can be reduced substantially.

BRIEF DESCRIPTION OF THE DRAWINGS

[0012] FIG. 1 is a schematic view of a refractive index distribution film of the present invention.

[0013] FIG. 2 is a first schematic view of a method of manufacturing a refractive index distribution film in accordance with a preferred embodiment of the present invention.

[0014] FIG. 3 is a second schematic view of a method of manufacturing a refractive index distribution film in accordance with a preferred embodiment of the present invention.

[0015] FIG. 4 is a first schematic view of a method of manufacturing a refractive index distribution film in accordance with another preferred embodiment of the present invention.

[0016] FIG. 5 is a second schematic view of a method of manufacturing a refractive index distribution film in accordance with a first preferred embodiment of the present invention.

[0017] FIG. 6 is a schematic view of a liquid crystalline polymer lens structure in accordance with a second preferred embodiment of the present invention.

[0018] FIG. 7 is a schematic view of a liquid crystalline polymer lens structure in accordance with a third preferred embodiment of the present invention.

[0019] FIG. 8 is a first schematic view showing the lens effect of a liquid crystalline polymer lens structure in accordance with the third preferred embodiment of the present invention.

[0020] FIG. 9 is a second schematic view showing the lens effect of a liquid crystalline polymer lens structure in accordance with the third preferred embodiment of the present invention.

[0021] FIG. 10 is a schematic view of a liquid crystalline polymer lens structure in accordance with a fourth preferred embodiment of the present invention.

[0022] FIG. 11 is a schematic view of a liquid crystalline polymer lens structure in accordance with a fifth preferred embodiment of the present invention.

[0023] FIG. 12 is a schematic view of a liquid crystalline polymer lens structure in accordance with a sixth preferred embodiment of the present invention.

[0024] FIG. 13A and FIG. 13B are schematic diagrams illustrating an optical system with an aberration compensation function in accordance with one embodiment of the present invention.

[0025] FIG. 14A and FIG. 14B are schematic diagrams illustrating an optical system with an aberration compensation function in accordance with one embodiment of the present invention.

[0026] FIG. 15A and FIG. 15B are schematic diagrams illustrating an optical system with an aberration compensation function in accordance with one embodiment of the present invention.

[0027] FIG. 16A and FIG. 16B are schematic diagrams illustrating an optical system with an aberration compensation function in accordance with one embodiment of the present invention.

[0028] FIG. 17A and FIG. 17B are schematic diagrams illustrating an optical system with an aberration compensation function in accordance with one embodiment of the present invention.

[0029] FIG. 18A and FIG. 18B are schematic diagrams illustrating an optical system with an aberration compensation function in accordance with one embodiment of the present invention.

[0030] FIG. 19A and FIG. 19B are schematic diagrams illustrating a display system with an aberration compensation function in accordance with one embodiment of the present invention.

[0031] FIG. 20A and FIG. 20B are schematic diagrams illustrating a display system with an aberration compensation function in accordance with one embodiment of the present invention.

[0032] FIG. 21A, FIG. 21B, FIG. 21C and FIG. 21D are schematic diagrams illustrating a display system with an aberration compensation function in accordance with one embodiment of the present invention.

[0033] FIG. 22A, FIG. 22B, FIG. 22C and FIG. 22D are schematic diagrams illustrating a display system with an aberration compensation function in accordance with one embodiment of the present invention.

[0034] FIGS. 23A and 23B are schematic diagrams illustrating a display system with an aberration compensation function in accordance with one embodiment of the present invention.

DESCRIPTION OF THE PREFERRED EMBODIMENTS

[0035] The technical characteristics, contents, advantages and effects of the present invention will be apparent with the detailed description of a preferred embodiment accompanied with related drawings as follows. The drawings are provided

for the illustration, and same numerals are used to represent respective elements in the preferred embodiments. It is intended that the embodiments and drawings disclosed herein are to be considered illustrative rather than restrictive. Same numerals are used for representing same respective elements in the drawings.

[0036] With reference to FIG. 1 for a schematic view of a refractive index distribution film of the present invention, the refractive index distribution film 1 comprises a liquid crystalline molecule and a liquid crystalline polymer, and the refractive index distribution film 1 is flexible. In present embodiment, the refractive index distribution film 1 has an optical axis in a direction of the X-direction. In other embodiments of the present invention, the optical axis of the refractive index distribution film 1 can be in a direction of the Y-direction. The refractive index distribution film 1 of the present invention is made of a liquid crystalline polymer, so that it has the property of birefringence. In other words, the refractive index of incident lights having different polarizations and passing through the refractive index distribution film 1 varies. For example, when a light passes through the refractive index distribution film 1, the polarized light with a polarization direction in X-direction and the polarized light with a polarization direction in Y-direction have different focuses.

[0037] It is noteworthy that the refractive index distribution film 1 of present embodiment has a symmetric refractive index distribution in the XY-direction, and the refractive index distribution film 1 in other embodiments of the present invention may have an asymmetric refractive index distribution. For better understanding, the manufacturing method of a refractive index distribution film in accordance with embodiments of the present invention is described below.

[0038] With reference to FIG. 2 for a first schematic view of a method of manufacturing a refractive index distribution film in accordance with a preferred embodiment of the present invention, a two-voltage structure providing a non-uniform voltage distribution is adopted in this preferred embodiment to manufacture a refractive index distribution film 1 with a refractive index distribution having a circular symmetry.

[0039] More specifically, components used for manufacturing a refractive index distribution film include a glass substrate 12, 20, a transparent electrode 14, 18, 26, alignment layer 22, 24 and an insulating layer 16. Wherein, the components used for manufacturing the refractive index distribution film are disposed on the glass substrate 12, the transparent electrode 14, the insulating layer 16, the transparent electrode 18, the glass substrate 20, the alignment layer 22, the alignment layer 24, the transparent electrode 26 and the glass substrate 28 along the Z-direction. The mixture of a liquid crystal and a liquid crystalline polymer used for forming the refractive index distribution film 1 is disposed between the alignment layer 22 and the alignment layer 24. Wherein, the transparent electrode 18 is designed as a circular electrode layer; the transparent electrode 14, 20 is designed as a planar electrode structure; a first voltage V_1 is applied between the transparent electrodes 18 and 26, and a second voltage V_2 is applied between the transparent electrodes 14 and 26 to form a circular symmetric voltage distribution.

[0040] By controlling the magnitude of the first voltage V_1 and the second voltage V_2 , the mixture of the liquid crystal and the liquid crystalline polymer in the refractive index distribution film 1 can be adjusted to form a circular symmetric refractive index distribution. Wherein, the glass substrate

12, 20, 28 of this preferred embodiment can be substituted by a material with high dielectric constant or high impedance.

[0041] With reference to FIG. 3 for a second schematic view of a method of manufacturing a refractive index distribution film in accordance with an embodiment of the present invention, an ultraviolet (UV) light exposure can cure the mixture of the liquid crystal and liquid crystalline polymer, and the refractive index distribution film 1 undergoes a phase separation. In other words, the liquid crystal and polymer in the refractive index distribution film 1 are cured and peeled off the refractive index distribution film 1 from the components used for manufacturing the refractive index distribution film 1.

[0042] With reference to FIG. 4 for a first schematic view of a method of manufacturing a refractive index distribution film in accordance with another embodiment of the present invention, the difference between the manufacturing method of this embodiment and the manufacturing method as shown in FIG. 2 resides on this embodiment adopts a circular asymmetric glass substrate to achieve the non-uniform electric field for manufacturing the refractive index distribution film 1 with a non-uniform refractive index distribution.

[0043] More specifically, components used for manufacturing a refractive index distribution film include a glass substrate 30, 32, a transparent electrode 34, 36, and an alignment layer 38, 40. Wherein, the components used for manufacturing the refractive index distribution film are disposed along the Z-direction include a transparent electrode 34, a glass substrate 30, an alignment layer 38, an alignment layer 40, a transparent electrode 36 and a glass substrate 32, and a mixture of a liquid crystal and a liquid crystalline polymer used for forming the refractive index distribution film 1 is disposed between the alignment layer 38 and the alignment layer 40. In the present embodiment, a voltage V_3 is applied between the transparent electrode 34 and the transparent electrode 36, and the glass substrate 30 is designed thicker on a side and thinner on the other opposite side to achieve a non-uniform electric field distribution. In other words, the electric field at a position on the thicker side is smaller, and the electric field at a position on the thinner side is greater, so that a refractive index distribution film with a gradual refractive index distribution can be manufactured.

[0044] In addition to the aforementioned manufacturing method, another method of using a pixel electrode to drive a liquid crystal and a liquid crystalline polymer mixture at different positions in the refractive index distribution film 1 to manufacture a refractive index distribution film with a non-uniform refractive index distribution, such as the aforementioned refractive index distribution film with a gradual and symmetric refractive index distribution or the refractive index distribution film with any refractive index distribution.

[0045] With reference to FIG. 5 for a second schematic view of a method of manufacturing a refractive index distribution film in accordance with a first embodiment of the present invention, the liquid crystalline polymer lens structure 2 comprises a flexible substrate 100, a first lens 110 and a first refractive index distribution film 120.

[0046] The first refractive index distribution film 120 composed of a liquid crystal and a liquid crystalline polymer having the feature of birefringence is manufactured by the aforementioned method and encapsulated inside a flexible substrate 100. The first refractive index distribution film 120 has a first refractive index in the X-direction and a second refractive index in the Y-direction.

[0047] The flexible substrate 100 is a laminating film or a flexible plastic substrate used for packaging the first refractive index distribution film 120. In the present embodiment, after the first refractive index distribution film is packaged inside the flexible substrate 100, and an adhesive 121 can be coated onto a side of the flexible substrate 100 and adhered with a first side 111 of the first lens 110, so that the focal length of the first lens 110 can be adjusted. In industrial applications, the flexible substrate 100 encapsulated with the first refractive index distribution film 120 can be laminated onto a glasses lens for adjusting the power of the glasses.

[0048] With reference to FIG. 6 for a schematic view of a liquid crystalline polymer lens structure in accordance with a second embodiment of the present invention, the difference between the liquid crystalline polymer lens structure 2 of the first embodiment and the liquid crystalline polymer lens structure 3 of the present embodiment resides on that the liquid crystalline polymer lens structure 3 further comprises a second refractive index distribution film 130 which is a mixture of a liquid crystal and a liquid crystalline polymer and encapsulated inside flexible substrate 100 according to the aforementioned method, so that the liquid crystalline polymer lens structure 3 has the feature of birefringence. The second refractive index distribution film 130 has a third refractive index in the X-direction and the fourth refractive index in the Y-direction.

[0049] In the present embodiment, the second refractive index distribution film 130 is encapsulated inside the flexible substrate 100, and the first refractive index distribution film 120 has an optical axis in the X-direction, and the second refractive index distribution film 130 has an optical axis in the Y-direction. Wherein, the flexible substrate 100 can be a laminating film or a flexible plastic film for encapsulating the first refractive index distribution film 120 and the second refractive index distribution film 130. With the two refractive index distribution films 120, 130 with their optical axes perpendicular to each other, the liquid crystalline polymer lens structure 3 of the present embodiment can achieve the expected effect without requiring the polarizer.

[0050] With reference to FIG. 7 for a schematic view of a liquid crystalline polymer lens structure in accordance with a third preferred embodiment of the present invention, the major difference between the liquid crystalline polymer lens structure 4 of this preferred embodiment and the liquid crystalline polymer lens structure 3 of the second preferred embodiment resides on that the liquid crystalline polymer lens structure 4 of this preferred embodiment further comprises a second lens 140, and the second lens 140 has a second side 141 opposite to the first side 111 of the first lens 110, and the flexible substrate 100 laminated between the first side 111 and the second side 141 by the adhesive 121.

[0051] It is noteworthy that each liquid crystalline polymer lens structure 2, 3, 4 of the first embodiment, the second embodiment and the third embodiment has the first refractive index and the second refractive index of the first refractive index distribution film 120 and the third refractive index and the fourth refractive index of the second refractive index distribution film 130 in the X- and Y-directions, and also has a circular symmetric optical power, a gradual optical power or any refractive index distribution. By adjusting the refractive index distribution of the refractive index distribution film in the X- and Y-directions, the focal length of the lens or the power of glasses can be adjusted.

[0052] With reference to FIG. 8 for a first schematic view showing the lens effect of a liquid crystalline polymer lens structure in accordance with the third embodiment of the present invention, the refractive index distribution film manufactured according to the method as shown in FIG. 2 is used as an example. Since the liquid crystalline polymer molecules at the ends of the first refractive index distribution film 120 and the second refractive index distribution film 130 are erected, therefore the refractive index remains unchanged and there is no lens effect. Other parts of the first refractive index distribution film 120 and the second refractive index distribution film 130 have a single lens effect due to the distribution of the liquid crystal molecules.

[0053] With reference to FIG. 9 for a second schematic view showing the lens effect of a liquid crystalline polymer lens structure in accordance with the third embodiment of the present invention, the refractive index distribution film manufactured according to the method as shown in FIG. 4 is used as an example. Since the liquid crystalline polymer molecules at the ends of the first refractive index distribution film 120 and the second refractive index distribution film 130 are erected, therefore the refractive index remains unchanged and there is no lens effect. The optical power is increasing gradually along the X-direction for providing additional optical power to improve the presbyopia's reading ability.

[0054] With reference to FIG. 10 for a schematic view of a liquid crystalline polymer lens structure in accordance with a fourth embodiment of the present invention, the liquid crystalline polymer lens structure 5 comprises a first lens 200, a second lens 240, a first electrode layer 250, a second electrode layer 260 and a composite layer 270. Wherein, the first lens 200 has a first side 211, and the second lens 240 has a second side 241 facing the first side 211. The first electrode layer 250 is disposed on the first side 211 of the first lens 200, and the second electrode layer 260 is disposed on the second side 241 of the second lens 240. The composite layer 270 is disposed between the first electrode layer 250 and the second electrode layer 260, and the composite layer 270, arranged along the direction from the first electrode layer 250 to the second electrode layer 260 (which is the Z-direction), sequentially comprises a first alignment layer 280, a first liquid crystal layer 290 and a first refractive index distribution film 120.

[0055] Wherein, the first alignment layer 280 is disposed on the first electrode layer 250, and the first liquid crystal layer 290 is disposed on the first alignment layer 280, and the first refractive index distribution film 120 is disposed on the first liquid crystal layer 290. Wherein, the first refractive index distribution film is the refractive index distribution film 120 manufactured by the aforementioned method and composed of a liquid crystal and a macromolecular polymer, and the first refractive index distribution film has the feature of birefringence.

[0056] With the first liquid crystal layer 290 in the composite layer 270 as shown in the figure, if a voltage V is applied between the first electrode layer 250 and the second electrode layer 260, the arrangement of the liquid crystals in the first liquid crystal layer will be affected and rotated, so that the polarization direction of the incident light can be changed, and the focal length of the liquid crystalline polymer lens structure 5 can be changed. If an additional polarizer 300 is added at a position opposite to the first side 211 of the first lens 200, the liquid crystalline polymer lens structure 5 can be used as a signal switch of the optical signal or applied in 3D display technologies.

[0057] With reference to FIG. 11 for a schematic view of a liquid crystalline polymer lens structure in accordance with a fifth embodiment of the present invention, the composite layer 270 of the liquid crystalline polymer lens structure 6 along the Z-direction further comprises a second refractive index distribution film 130, a second liquid crystal layer 310 and a second alignment layer 320. Wherein, the second refractive index distribution film 130 is the refractive index distribution film 130 manufactured by the aforementioned method and composed of a liquid crystal and a macromolecular polymer, and the second refractive index distribution film 130 has the feature of birefringence.

[0058] The second liquid crystal layer 310 is disposed on the second refractive index distribution film 130, and the second alignment layer 320 is disposed on the second liquid crystal layer 310. Wherein, the alignment direction of the first liquid crystal layer 290 is different from the alignment direction of the second liquid crystal layer 310, and the alignment direction of the first refractive index distribution film 120 is different from the alignment direction of the second refractive index distribution film 130. Since the liquid crystalline polymer distribution film has a dielectric constant distribution and an ability of aligning liquid crystals, therefore this present embodiment with the design of the liquid crystal and the electrode layer can achieve the effect of a dynamic lens. For example, if no voltage is applied between the electrode layers in the present embodiment, the liquid crystalline polymer lens structure 6 will have a constant optical power. On the other hand, if a voltage is applied between the electrode layers, the liquid crystalline polymer lens structure 6 will have a continuous optical power distribution.

[0059] It is noteworthy that by adjusting the alignment directions of the first alignment layer 280 and the second alignment layer 320, the first liquid crystal layer 290 or the second liquid crystal layer 310 of the present embodiment can be aligned as an anti-parallel alignment, a vertical alignment, a hybrid alignment or a twisted nematic alignment.

[0060] With reference to FIG. 12 for a schematic view of a liquid crystalline polymer lens structure in accordance with a sixth embodiment of the present invention, the liquid crystalline polymer lens structure 7 comprises a refractive index distribution film 10, a polarizer 400 and a polarization controller 410. The refractive index distribution film 10 is the refractive index distribution film 130 manufactured by the aforementioned method and composed of a liquid crystal and a liquid crystalline polymer, and the refractive index distribution film 10 has the feature of birefringence.

[0061] The polarizer 400 is installed on a side of the refractive index distribution film 10, and the polarization controller 410 is installed between the polarizer 400 and the refractive index distribution film 10. Wherein, the polarization controller 410 is used for changing the polarization direction of a polarized light passing through the polarizer 400 in order to change the focal length of the liquid crystalline polymer lens structure 7. For example, if the polarization controller 410 changes the polarization direction of the polarized light passing through the polarizer 400 from the X-direction to the Y-direction or vice versa, the liquid crystalline polymer lens structure 7 will have two different optical power distributions.

[0062] In one embodiment, the refractive index distribution film may be utilized to compensate the aberration generated by an optical module. Referring to FIG. 13A and FIG. 13B, FIG. 13A and FIG. 13B are schematic diagrams illustrating an optical system with an aberration compensation function

of the present invention. As shown in the figures, the optical system **8** comprises an optical module **80** and a refractive index distribution film **10**. The optical module **80** has a curved surface, such as numeral **81** and **82**, and the optical module can be a single element or an element comprising at least two components, wherein the optical module comprises a lens or a curved reflector. The refractive index distribution film **10** comprises a liquid crystal and a liquid crystalline polymer, wherein a refractive index distribution of the refractive index distribution film **10** is asymmetric and the tilt angle of the liquid crystal of the refractive index distribution film is fixed and cannot be changed by an external electronic device. The refractive index distribution film **10** is arranged on a first side **81** or a second side **82** of the optical module **80**. In one embodiment, the refractive index distribution film **10** is directly adhered on the first side **81** or a second side **82** of the optical module **80**; and the first side **81** is a light entrance surface of the optical module **80** and the second side **82** is a light exit surface of the optical module **80**. In another embodiment, the refractive index distribution film **10** can be modularly attached on the first side **81** or a second side **82** of the optical module **80** (as shown in FIGS. **13A** and **13B**, position P_1). An incident light L_m can pass through the refractive index distribution film **10** and the optical module **80** to compensate the aberration generated by the optical module **80**. Besides, due to the refractive index distribution film **10** is flexible, the refractive index distribution film **10** can be easily and smoothly attached on the curved surface of the optical module.

[**0063**] Continuing the above description, in one embodiment, the optical module comprises a free form lens. As shown in FIGS. **14A** and **14B**, the optical module **80** comprises the free form lens **800** and a see-through corrector **810**. The see-through corrector **810** is attached on a third side **803** of the free form lens **800**. As shown in FIG. **14A**, the refractive index distribution film **10** is arranged on the first side (light entrance surface) **801** (position P_2) of the free form lens **800**. It can be understood that the refractive index distribution film **10** also can be attached on the second side (light exit surface) **803** of the free form lens (such as shown in FIG. **14B**, position P_2). As abovementioned description, the refractive index distribution film **10** can be directly adhered on the light entrance surface or the light exit surface (as shown in FIGS. **14A** and **14B**, position P_2), or modularly attached on the first side **801** or the second side **802** (shown in FIGS. **14A** and **14B**, position P_1). An incident light L_m passes through the free form lens **800** from the first side **801**, and the incident light L_m is reflected by the second side **802** and the third side **803** to pass through the second side **802** of the free form lens **800**. The refractive index distribution film **10** is utilized to set on the light entrance surface **801** or the light exit surface **802** to compensate the aberration generated from the incident light, which is an off-axis light or has a large incident angle, passing through the optical module.

[**0064**] In another embodiment, the optical module of the optical system comprises a curved reflector. Referring to FIGS. **15A** and **15B**, take a curved reflector array **820** for example, the refractive index distribution film **10** is arranged on the first side (light entrance surface) **821** or the second side (light exit surface) **822** of the curved reflector array **820**.

[**0065**] In yet another embodiment, the optical module of the optical system comprises a lens and a beam splitter. Referring to FIGS. **16A** and **16B**, the lens **830** is set on a light entrance side of the beam splitter **840**; and the refractive index

distribution film **10** is arranged on the first side (light entrance surface) **831** or the second side (light exit surface) **832** of the lens **830**. As shown in FIG. **16B**, the refractive index distribution film **10** also can be arranged on the first side (light entrance surface) **841** or the second side (light exit surface) **842** of the beam splitter **840**.

[**0066**] In yet another embodiment, the optical module of the optical system comprises a lens and a reflector. Referring to FIGS. **17A** and **17B**, the lens **830** is set on a light entrance side of the reflector **850**; and the refractive index distribution film **10** is arranged on the first side (light entrance surface) **831** (position P_1 and P_2) or the second side (light exit surface) **832** (position P_3 , P_4) of the lens **830**. As shown in FIG. **17B**, the refractive index distribution film **10** also can be set on a first side (light entrance side) **851** or a second side (light exit side) **852** of the reflector **850**.

[**0067**] In yet another embodiment, the optical module of the optical system comprises a curved mirror. As shown in FIGS. **18A** and **18B**, the refractive index distribution film **10** is arranged on the first side (light entrance surface) **861** or the second side (light exit surface) **862** of the curved mirror **860**.

[**0068**] In one embodiment, the display system comprises an optical system and an image panel, in one embodiment, the display system comprises but not limited to a head-mount display. The optical system comprises an optical module and a refractive index distribution film, wherein the optical module comprises a curved surface, such as a lens or a curved reflector. The refractive index distribution film comprises a liquid crystal and a liquid crystalline polymer, wherein a refractive index distribution of the refractive index distribution film is asymmetric; the refractive index distribution film is arranged on a first side or a second side of the optical module; and the refractive index distribution film is utilized to compensate the aberration generated by the optical module. The image panel for displaying an image, wherein the image panel set on a light entrance side of the optical system, and the image light projected from the image panel passes through the optical system to a viewer's eyes. In one embodiment, the refractive index distribution film is attached on a first side (light entrance surface) or a second side (light exit surface) of the optical module.

[**0069**] Continuing the above description, in one embodiment, the lens comprises a free form lens. As shown in FIGS. **19A** and **19B**, FIG. **19A** and FIG. **19B** are schematic diagrams illustrating a display system **9** with an aberration compensation function of the present invention. In the embodiment, the display system comprises an image panel **90** and an optical system **91**, and the optical module **91** comprises the free form lens **910** and a see-through corrector **920**. The see-through corrector **920** is attached on a third side **913** of the free form lens **910**. As shown in FIG. **19A**, the refractive index distribution film **10** is arranged on the first side (light entrance surface) **911** (may be set on position P_1 or position P_2) of the free form lens **910**. It can be understood that the refractive index distribution film **10** also can be attached on the second side (light exit surface) **912** of the free form lens **910** (such as shown in FIG. **19B**, may be set on position P_1 or position P_2). An image light L_i passes through the free form lens **910** from the first side **911**, and the image light L_i is reflected by the second side **912** and the third side **913** to pass through the second side **912** of the free form lens **910**. Due to the margin of the panel is the incident light having a large incident angle for the optical element, the aberration is generated by the optical module. The refractive index distribution film **10** is

utilized to set on the light entrance surface **911** or the light exit surface **912** to compensate the aberration generated from the incident light, which is an off-axis light or has a large incident angle, passing through the optical module. Besides, the see-through corrector **920** set on the third side **913** is utilized to compensate the image distortion generated by an ambient light L_a .

[0070] In another embodiment, the optical module of the display system comprises a curved reflector. Referring to FIGS. **20A** and **20B**, take a curved reflector array **930** for example, the refractive index distribution film **10** is attached on the first side (light entrance side) **931** or the second side (light exit side) **932** of the curved reflector array **930**. The image light L_i projected from the image panel **90** passes through the optical module **91** and the refractive index distribution film **10** to reflect into a viewer's eyes **500**; and the refractive index distribution film **10** is utilized to compensate the aberration generated by the optical system **91**.

[0071] In yet another embodiment, the optical module of the display system comprises a lens and a beam splitter. Referring to FIGS. **21A** and **21B**, the lens **940** is set on a light entrance side of the beam splitter **950**; and the refractive index distribution film **10** is arranged on the first side (light entrance surface) **941** or the second side (light exit surface) **942** (may be adhered on position P_1 or attached on position P_2) of the lens **940**. As shown in FIG. **21C** and FIG. **21D**, the refractive index distribution film **10** also can be attached on the first side (light entrance surface) **951** or the second side (light exit surface) **952** of the beam splitter **950**.

[0072] In yet another embodiment, the optical module of the display system comprises a lens and a reflector. Referring to FIGS. **22A** and **22B**, the lens **940** is set on a light entrance side of the reflector **960**; and the refractive index distribution film **10** is arranged on the first side (light entrance surface) **941** or the second side (light exit surface) **942** (may be adhered on position P_1 or attached on position P_2) of the lens **940**. As shown in FIG. **22C** and FIG. **22D**, the refractive index distribution film **10** also can be set on a first side (light entrance side) **961** or a second side (light exit side) **962** of the reflector **960**.

[0073] In yet another embodiment, the optical module of the display system comprises a curved mirror. As shown in FIGS. **23A** and **23B**, the refractive index distribution film **10** is arranged on the first side (light entrance surface) **971** or the second side (light exit surface) **972** of the curved mirror **970**.

[0074] In summation of the description above, the refractive index distribution film has a plurality of the refractive index distribution and the tilt angle of the liquid crystal of the refractive index distribution film is fixed and cannot be changed by an external electronic device. Due to no additional electrically-controlled component is needed to change the refractive index distribution, the production cost can be reduced substantially. Besides, the refractive index distribution film can be encapsulated by a flexible substrate and laminated onto a glasses lens for changing the power of glasses, providing additional optical power for a presbyopia's reading ability. Moreover, the refractive index distribution film can be adhered onto or attached on an optical module to compensate the aberration generated by the optical module which has an off-axis incident light or has a large incident angle. Therefore, the refractive index distribution film of the present invention can be applied onto various kinds of lenses or curved reflector easily or laminated onto an optical module to act as a simple and convenient lens sticker.

[0075] While the means of specific embodiments in present invention has been described by reference drawings, numerous modifications and variations could be made thereto by those skilled in the art without departing from the scope and spirit of the invention set forth in the claims.

What is claimed is:

1. An optical system with an aberration compensation function, comprising:

an optical module, comprising a curved surface; and

a refractive index distribution film comprising a liquid crystal and a liquid crystalline polymer, wherein a refractive index distribution of the refractive index distribution film is asymmetric and the tilt angle of the liquid crystal of the refractive index distribution film is fixed; the refractive index distribution film is arranged on a first side or a second side of the optical module; and the refractive index distribution film is utilized to compensate the aberration generated by the optical module.

2. The optical system according to claim 1, wherein the optical module comprises a lens or a curved reflector.

3. The optical system according to claim 1, wherein the optical module comprises a free form lens.

4. The optical system according to claim 1, wherein the optical module comprises a free form lens and a see-through corrector; the first side is a light entrance surface of the free form lens; the second side is a light exit surface of the free form lens; the see-through corrector is attached on a third side of the free form lens; and an incident light passes through the free form lens from the first side, and the incident light is reflected by the second side and the third side to pass through the second side of the free form lens.

5. The optical system according to claim 1, wherein the optical module comprises a lens and a beam splitter; the lens is set on a light entrance side of the beam splitter; and the first side is a light entrance surface or a light exit surface of the lens; and the second side is a light entrance surface or a light exit surface of the beam splitter.

6. The optical system according to claim 1, wherein the optical module comprises a lens and a reflector; the lens is set on a light entrance side of the reflector; the first side is a light entrance surface or a light exit surface of the lens; the second side is a light entrance surface or a light exit surface of the reflector.

7. The optical system according to claim 1, wherein the optical module comprises a curved reflector array; and the refractive index distribution film is set on a light entrance side or a light exit side of the curved reflector array.

8. The optical system according to claim 1, wherein the refractive index distribution film is flexible.

9. The optical system according to claim 1, wherein the refractive index distribution film is directly adhered on the first side or the second side of the optical module.

10. A display system with an aberration compensation function, comprising:

an optical system, comprising:

an optical module, comprising a curved surface; and

a refractive index distribution film comprising a liquid crystal and a liquid crystalline polymer, wherein a refractive index distribution of the refractive index distribution film is asymmetric and the tilt angle of the liquid crystal of the refractive index distribution film is fixed; the refractive index distribution film is arranged on a first side or a second side of the optical

module; and the refractive index distribution film is utilized to compensate the aberration generated by the optical module;

an image panel for displaying an image, wherein the image panel set on a light entrance side of the optical system, and the image light projected from the image panel passes through the optical system to a viewer's eyes.

11. The display system according to claim **10**, wherein the optical module comprises a lens or a curved reflector.

12. The display system according to claim **10**, wherein the optical module comprises a free form lens.

13. The display system according to claim **10**, wherein the optical module comprises a free form lens and a see-through corrector; the first side is a light entrance surface of the free form lens; the second side is a light exit surface of the free form lens; the see-through corrector is attached on a third side of the free form lens; and the image light projected from the image panel passes through the free form lens from the first side, and the image light is reflected by the second side and the third side to pass through the second side of the free form lens into the viewer's eyes.

14. The display system according to claim **10**, wherein the optical module comprises a lens and a beam splitter; the lens is set on a light entrance side of the beam splitter; the first side is a light entrance surface or a light exit surface of the lens; and the second side is a light entrance surface or a light exit

surface of the beam splitter; and the image light projected from the image panel passes through the refractive index distribution film, the lens, and the beam splitter to reflect into the viewer's eyes.

15. The display system according to claim **10**, wherein the optical module comprises a lens and a reflector; the lens is set on a light entrance side of the reflector; and the first side is a light entrance surface or a light exit surface of the lens; the second side is a light entrance surface or a light exit surface of the reflector; and the image light projected from the image panel passes through the refractive index distribution film, the lens, and the reflector to reflect into the viewer's eyes.

16. The display system according to claim **10**, wherein the optical module comprises a curved reflector array; and the refractive index distribution film is attached on the first side or the second side of the lens; and the image light projected from the image panel passes through the refractive index distribution film, the curved reflector array to reflect into the viewer's eyes.

17. The display system according to claim **10**, wherein the refractive index distribution film is flexible.

18. The display system according to claim **10**, wherein the refractive index distribution film is directly adhered on the first side or the second side of the optical module.

* * * * *