



US 20150313455A1

(19) **United States**

(12) **Patent Application Publication**
OU-YANG et al.

(10) **Pub. No.: US 2015/0313455 A1**

(43) **Pub. Date: Nov. 5, 2015**

(54) **PORTABLE NONINVASIVE INSPECTION
DEVICE**

Publication Classification

(71) Applicant: **NATIONAL CHIAO TUNG
UNIVERSITY**, Hsinchu City 300 (TW)

(51) **Int. Cl.**
A61B 1/24 (2006.01)
A61B 1/00 (2006.01)
A61B 5/00 (2006.01)

(72) Inventors: **Mang OU-YANG**, Hsinchu City 30055 (TW); **Ting-Wei HUANG**, Taipei City 10852 (TW); **Chin-Siang YANG**, Taichung City 40854 (TW); **Yao-Fang HSIEH**, Taipei City 11695 (TW); **Sing-Tsung LI**, Taichung City 40454 (TW); **Jin-Chern CHIOU**, Hsinchu City 30070 (TW); **Ming-Hsui TSAI**, Taichung City 40402 (TW); **Jeng-Ren DUANN**, Taichung City 40447 (TW); **Yung-Jiun LIN**, Taichung City 40447 (TW); **Shuen-De WU**, Taipei City 10648 (TW)

(52) **U.S. CL.**
CPC *A61B 1/24* (2013.01); *A61B 5/0071* (2013.01); *A61B 1/00186* (2013.01)

(21) Appl. No.: **14/750,030**

(22) Filed: **Jun. 25, 2015**

(57) **ABSTRACT**

The present invention discloses a portable noninvasive inspection device, which comprises a light source illuminates a target to generate an optical inspection signal; a probe head provides an optical path for said light source to receive said optical inspection signal; at least one switched filter module arranged in the optical path, allowing the optical inspection signal to pass there through to generate a corresponding spectral signal; and an image sensor arranged behind the switched filter module, receiving the spectral signal and generating a spectral image. The spectral image can be transmitted to an external device, wherefrom the user can use the spectral image to examine the target in further detail. The present invention features a rotary-type or movable-type switched filter module, which facilitates the user to switch filters easily during optical inspection and expands the application of the present invention.

Related U.S. Application Data

(62) Division of application No. 14/066,858, filed on Oct. 30, 2013.

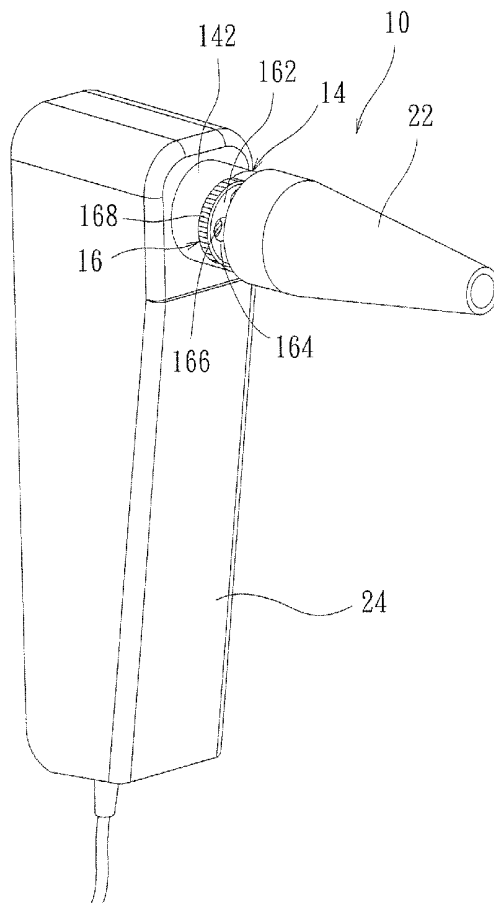

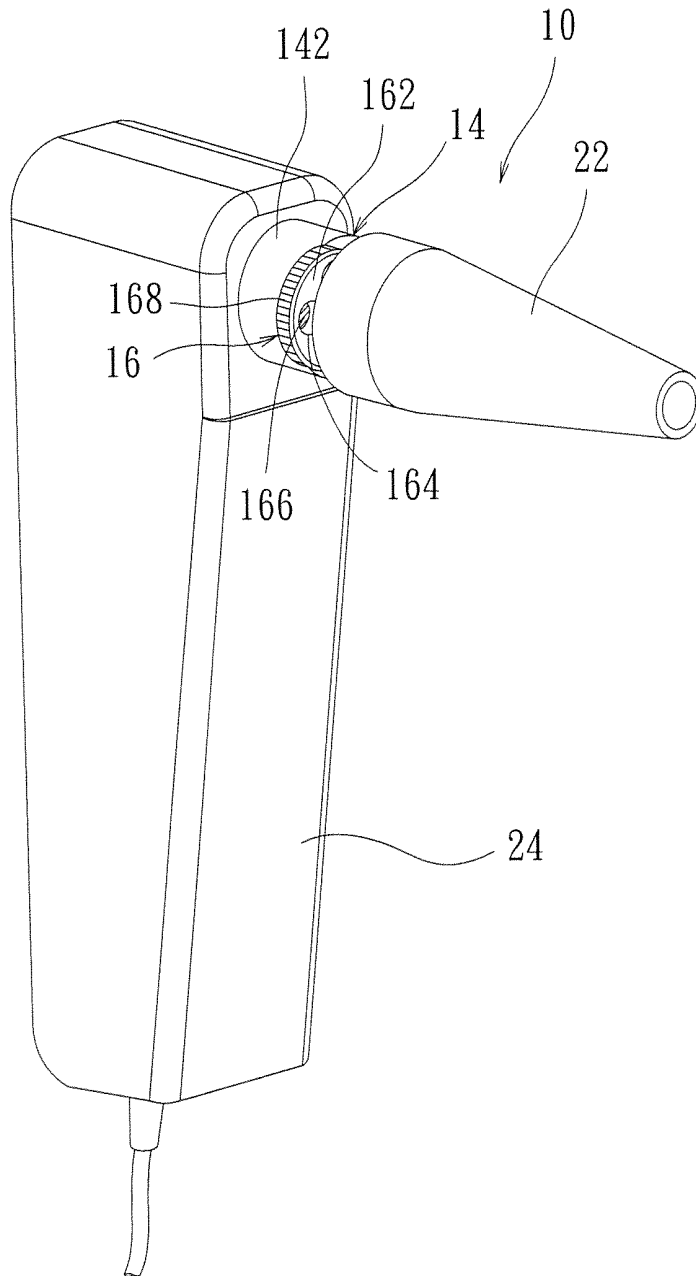

Fig. 1

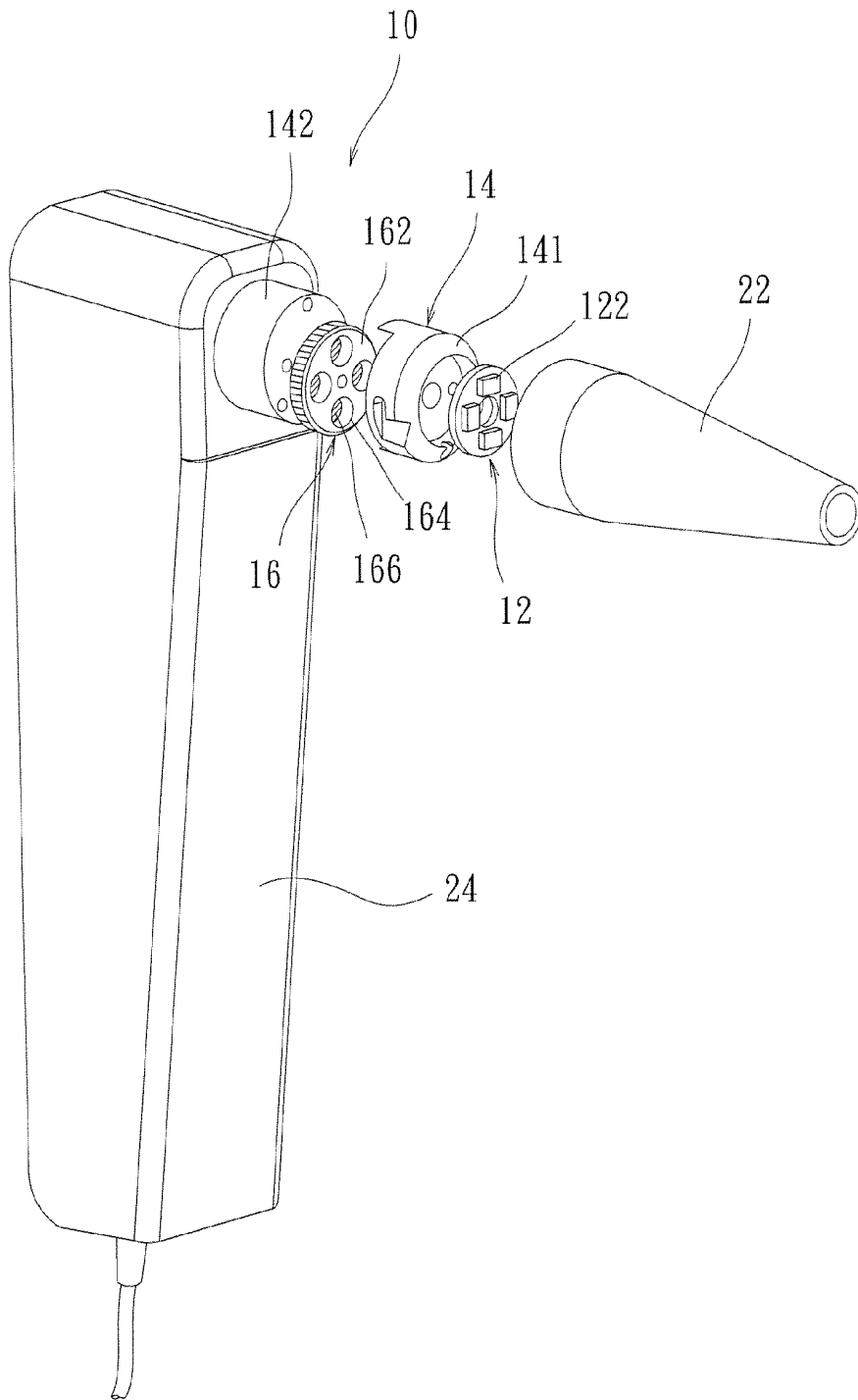

Fig. 2

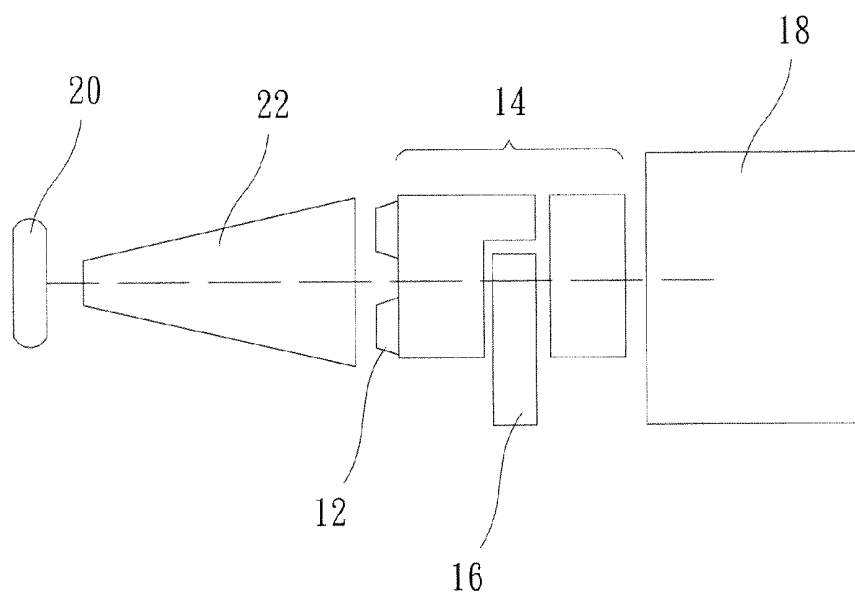

Fig. 3

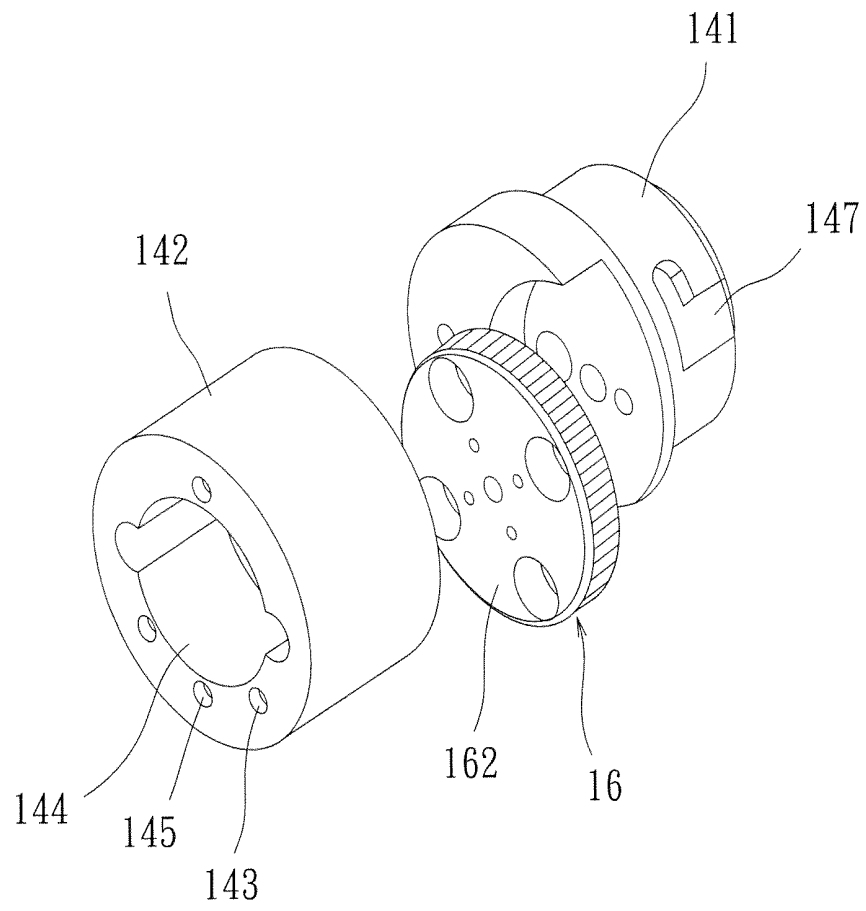

Fig. 4

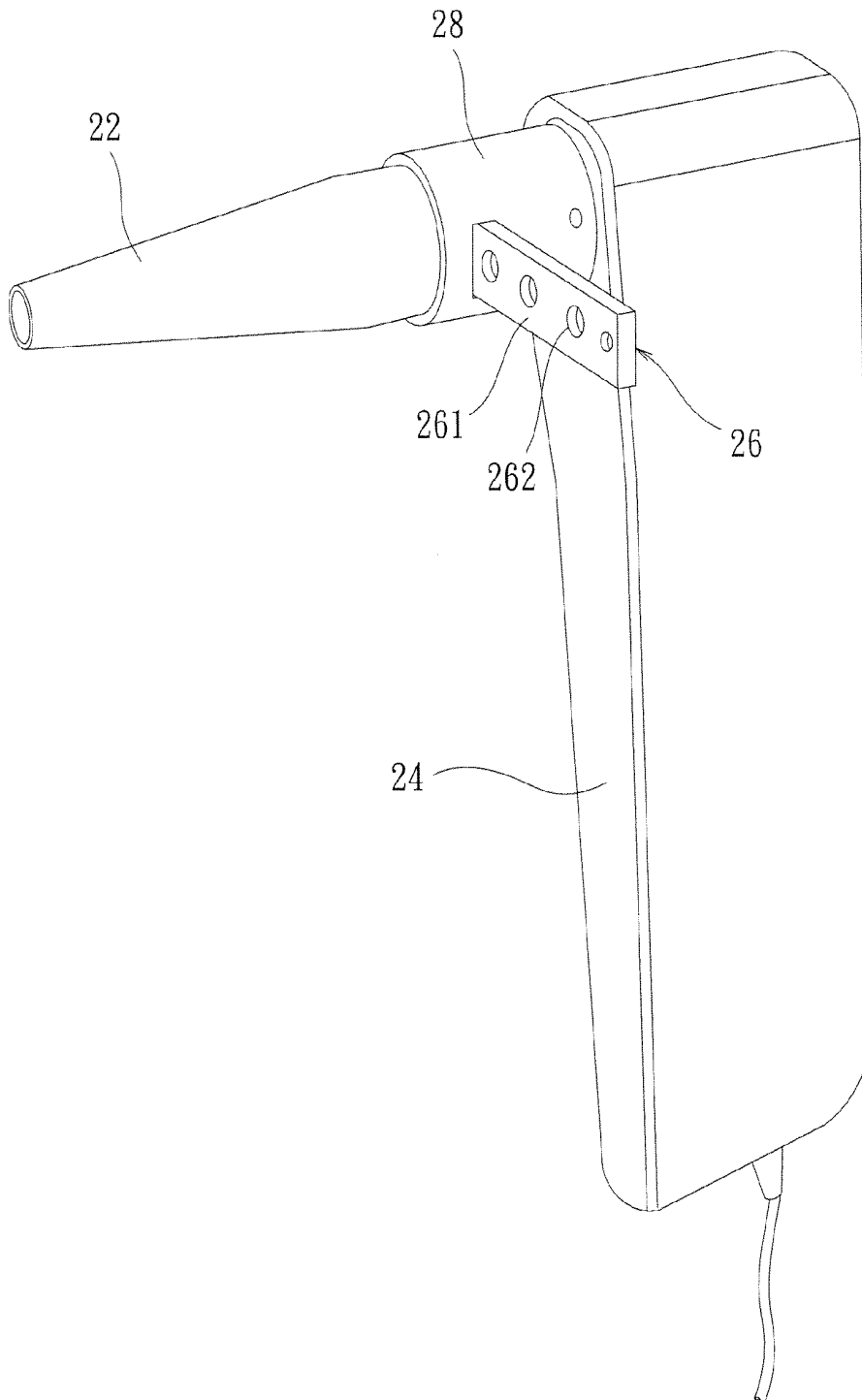

Fig. 5

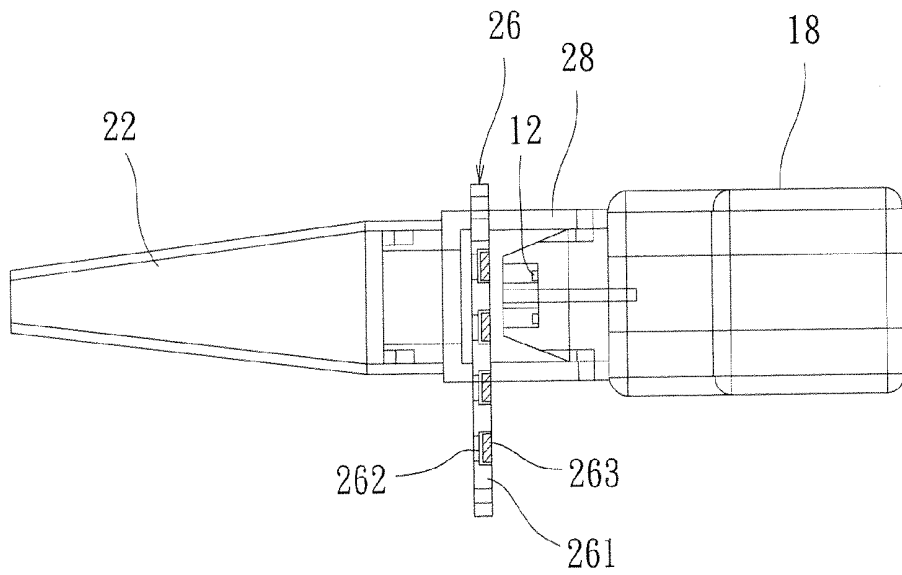

Fig. 6

PORTABLE NONINVASIVE INSPECTION DEVICE

RELATED APPLICATIONS

[0001] This application is a Divisional patent application of co-pending application Ser. No. 14/066,858, filed on 30 Oct. 2013, now pending. The entire disclosure of the prior application, Ser. No. 14/066,858 is considered a part of the disclosure of the accompanying Divisional application and is hereby incorporated by reference.

BACKGROUND OF THE INVENTION

[0002] 1. Field of the Invention

[0003] The present invention relates to a portable noninvasive inspection device, particularly to a portable noninvasive inspection device, which applies to optical inspection, and whose filters can be switched to meet different requirements.

[0004] 2. Description of the Related Art

[0005] With advance of inspection technology, there have been various devices for medical inspection in the market. The physicians can diagnose the patients, referring to the inspection results of the inspection devices. The current inspection technology will be described with the exemplification of oral cavity inspection below.

[0006] In the current oral cavity inspection technology, the lesion is inspected optically and then biopsied in vivo for microscopic inspection to verify the diagnosis. The conventional oral cavity inspection process is pretty complicated. Further, as the conventional inspection equipment includes a microscope, it is bulky and inconvenient to carry about. Besides, the conventional inspection equipment is invasive to oral tissue and likely to cause physical and psychological discomfort to the testee.

[0007] Some handheld devices have been developed to overcome the disadvantages of the conventional inspection devices. For an example, Catherine F. Poh, et al. proposed in Paper 1 "Direct Fluorescence Visualization of Clinically Occult High-Risk Oral Premalignant Disease Using a Simple Hand-Held Device", wherein ultraviolet light is projected onto a target tissue of a testee, and the tester observes the target tissue through a central visualization channel. The prior-art device needs a power cable connected with the device body. Further, the prior-art device cannot store image data but requires the tester to diagnose the target tissue on the spot. For another example, Pierre M. Lane, et al. proposed in Paper 2 "Simple Device for the Direct Visualization of Oral-Cavity Tissue Fluorescence", wherein a special spectrum of light is emitted by a light source and conducted to the hand-held device by optical fiber and then projected onto the target tissue by a lens module. For a further example, Nicholas B. MacKinnon proposed in a U.S. Pat. No. 2006/6,110,106A1 a handheld device structure, which is applied to VELscope Vx (a product of the Velscope company), wherein the power supply and the light source are integrated with the handheld device to convenience operation. The prior-art device does not allow the tester to change the filter in the observation channel but still requires the tester to diagnose the target tissue on the spot.

[0008] In all the abovementioned conventional inspection devices, the filter is installed in the central visualization channel. In such a scenario, the tester is inconvenient to replace the filter for observing the fluorescent response of the target tissue under a different spectrum of light. Therefore, the

present invention proposes a portable noninvasive inspection device to overcome the abovementioned problems.

SUMMARY OF THE INVENTION

[0009] The primary objective of the present invention is to provide a portable noninvasive inspection device, wherein a switched filter module cooperates with an image sensor, and wherein the witch-mode filter module enables the tester to switch filters easily during optical inspection, whereby the image sensor can instantly obtain different spectral images of an identical target tissue through different filters.

[0010] Another objective of the present invention is to provide a portable noninvasive inspection device, wherein the light source is arranged on the probe head to directly illuminate the target tissue or excite fluorescence from the target tissue, whereby less light energy is consumed in transmission.

[0011] To achieve the abovementioned objectives, the present invention proposes a portable noninvasive inspection device, which comprises a light source illuminating a target, such as a lesion, to generate an optical inspection signal; a probe head providing an optical path for the light source to receive the optical inspection signal; at least one switched filter module arranged in the optical path and filtering the optical inspection signal to obtain a corresponding spectral signal; and an image sensor receiving the spectral signal and generating a spectral image.

[0012] In one embodiment, the switched filter module includes a rotation disc. The rotation disc has a plurality of positioning slots where filters are inserted. The rotation disc is used to switch the filters. In one embodiment, the switched filter module includes a movable plate. The movable plate has a plurality of positioning slots where filters are inserted. The movable plate is translated to switch the filters. No matter whether the switched filter module has a rotation disc or a movable plate, the filters can be switched manually or automatically.

[0013] In one embodiment, the portable noninvasive inspection device of the present invention further comprises a hand-held body accommodating the image sensor and connected with the probe head. A battery module is arranged inside the hand-held body, electrically connected with the light source and the image sensor and supplying power to the light source and the image sensor. A wireless transmission module is also arranged inside the hand-held body, electrically connected with the image sensor and wirelessly transmitting the spectral image to an external device. The design of the built-in battery module and the wireless transmission module greatly increases the convenience and mobility of the present invention in application and operation.

[0014] Below, the embodiments are described in detail in cooperation with the attached drawings to make easily understood the objectives, technical contents, characteristics and accomplishments of the present invention.

BRIEF DESCRIPTION OF THE DRAWINGS

[0015] FIG. 1 is a perspective view schematically showing a portable noninvasive inspection device according to the first embodiment of the present invention;

[0016] FIG. 2 is an exploded view schematically showing a portable noninvasive inspection device according to the first embodiment of the present invention;

[0017] FIG. 3 is a sectional view schematically showing a portable noninvasive inspection device according to the first embodiment of the present invention;

[0018] FIG. 4 is an exploded view schematically showing a front probe head structure, a rear probe head structure and a switched filter module of a portable noninvasive inspection device according to the first embodiment of the present invention;

[0019] FIG. 5 is a perspective view schematically showing a portable noninvasive inspection device according to a second embodiment of the present invention; and

[0020] FIG. 6 is an exploded view schematically showing a portable noninvasive inspection device according to the second embodiment of the present invention.

DETAILED DESCRIPTION OF THE INVENTION

[0021] The present invention proposes a portable noninvasive inspection device, which contains a switched filter module and a probe head having an image sensor, wherein a light source is used to illuminate the target tissue and generate an optical inspection signal, and wherein the tester can conveniently select a special filter to filter the optical inspection signal and obtain the filtered image.

[0022] The present invention proposes a portable noninvasive inspection device 10, which comprises a light source 12, a probe head 14, at least one switched filter module 16 and an image sensor 18. The light source 12 is used to illuminate a target 20 to generate an optical inspection signal. In the embodiment shown in FIGS. 1-3, the light source 12 is arranged at the front end of the probe head 14. The probe head 14 provides the light source 12 with an optical path. The probe head 14 receives the optical inspection signal and transmits the optical inspection signal through the optical path. The switched filter module 16 is arranged inside the probe head 14. In the embodiment shown in FIGS. 1-3, the filters are switched via rotation. The switched filter module 16 includes a rotation disc 162 having a plurality of positioning slots 164. Each positioning slot 164 accommodates a filter 166 inserted thereto. The rotation disc 162 is manually or automatically rotated to switch the filters 166 to make one filter 166 exactly aligned to the optical path. The optical inspection signal travels along the optical path and partially passes through the filter 166. The filter 166 filters the optical inspection signal and obtains a spectral signal. The image sensor 18 is arranged at the rear side of the probe head 14 and the switched filter module 16. The image sensor 18 senses the spectral signal and generates a corresponding spectral image, such as a biomedical image, a fluorescent image or a spectrum-based image. If the light source 12 is a light source for exciting the target 20, the target 20 will be excited to generate a fluorescent optical inspection signal. The fluorescent optical inspection signal is filtered by the switched filter module 16, and the image sensor 18 senses the filtered signal to form a fluorescent image. The portable noninvasive inspection device 10 further comprises a probe tube 22 arranged before the probe head 14 and used to provide a limited observation field area ranging from 0.1 mm-10 cm. The surface of the probe tube 22 and/or the surface of the probe head 14 are sand-blasted or blackened to reduce reflection and scattering of light. The portable noninvasive inspection device 10 further comprises a hand-held body 24 accommodates the image sensor 18 and connects with the probe head 14. The hand-held body 24, the probe head 14, and the probe tube 22 cooperate to form a pistol-like handheld device that the user can easily hold and operate.

[0023] In one embodiment, the light source 12 is realized by at least one LED (Light Emitting Diode) or at least one laser device. In one embodiment, the light source 12 is realized by a plurality of LEDs or laser devices arranged annularly. In the embodiment shown in FIGS. 1-3, the light source 12 is realized by a plurality of LEDs 122 arranged annularly. However, this embodiment is only to exemplify the present invention but not to limit the scope of the present invention. Refer to FIG. 4. The probe head 14 includes a front probe head structure 141 and a rear probe head structure 142. The front probe head structure 141 and the rear probe head structure are assembled together with a space penetrating there through to function as the optical path. The switched filter module 16 is arranged between the front probe head structure 141 and the rear probe head structure 142. The front probe head structure 141, the switched filter module 16 and the rear probe head structure 142 are assembled together to form a sub-system. The rear probe head structure 142 has several holes 143 for fixing the image sensor 18. A circular basin 144 is formed on the rear probe head structure 142 and used as the movement space of an imaging lens (not shown in the drawing) of the image sensor 18. The lower region of the rear probe head structure 142 has a wiring hole 145 where a power cable passes to reach the light source 12 at the front. The rotation disc 162 is eccentric to the central visualization channel, whereby the filter 166 can be aligned to the central visualization channel. The edge of the rotation disc 162 has a grooved rim 168 to convenience finger's swiveling the rotation disc 162. The lower region of the front probe head structure 141 has a wiring hole 146 corresponding to the wiring hole 145 of the rear probe head structure 142. One end of the wiring hole 146 extends to the nearby of the light source 12. Two laterals of the front probe head structure 141 have L-shaped grooves 147. The probe tube 22 is screwed into the L-shape grooves 147 and secured thereto. The front probe head structure 141 and the rear probe head structure 142 have positioning holes, and the positioning beads (not shown in the drawing) are press-fitted into the positioning holes to secure the rotation disc 162. Thus, the filter 166 can be correctly positioned and exactly aligned to the central visualization channel while the tester rotates the rotation disc 162.

[0024] The abovementioned embodiments feature the rotary-type switched filter module and the assembly-type probe head structure. The present invention further includes other embodiments, such as the embodiments featuring a movable-type switched filter module and a connection ring, which will be described in detail below. However, the present invention is not limited by the two groups of embodiments.

[0025] Refer to FIG. 5 and FIG. 6. The movable-type switched filter module 26 further comprises a movable plate 261 inserted into a connection ring 28, which functions as the probe head. The front end of the connection ring 28 is connected with the probe tube 22, and the rear end of the connection ring 28 is connected with the hand-held body 24, whereby the connection ring 28 joins with the probe tube 22 and the hand-held body 24 to form an integral structure. The light source 12 is arranged inside the connection ring 28, behind the movable-type switched filter module 26, and between the movable-type switched filter module 26 and the image sensor 18. The movable plate 261 has a plurality of positioning slots 262 where a plurality of filter 263 is inserted. The filters 263 are switched via translating the movable plate 262. In one embodiment, the movable plate 261 is made of a transparent material, such as acrylic or glass, lest the light

source **12** be shielded by the movable plate **261**. The connection ring **28** can be installed between the probe tube **22** and the image sensor **18** without obvious modification.

[0026] In the abovementioned embodiments, the light source is arranged before or behind the switched filter module. In some embodiments of the present invention, the light source is arranged before or beside the probe tube, whereby the light source is closer to the target and provides better illumination.

[0027] In some embodiments of the present invention, a battery module is built inside the hand-held body, electrically connected with the light source and the image sensor and supplying power to the light source and the image sensor. In some embodiments of the present invention, a wireless communication module is arranged inside the hand-held body, electrically connected with the image sensor and transmitting the spectral images to an external device. The design incorporating the battery module and the wireless communication module contributes convenience and mobility to the present invention in application and operation.

[0028] In conclusion, the present invention uses the rotary-type or movable-type switched filter module to switch filters fast and easily during optical inspection, whereby the image sensor can instantly obtain different spectral images of the same target tissue of the target through different filters. The images of the same target tissue, which are obtained through the filters corresponding to different spectral ranges, can be used to analyze the biochemical features of the target tissue. Besides, the light source of the present invention is installed in the probe head, directly illuminating the target tissue or directly exciting the target tissue to generate fluorescence, whereby less light energy is lost in transmission.

[0029] The embodiments described above are to demonstrate the technical thought and characteristics of the present invention and enable the persons skilled in art to understand, make, and use the present invention. However, these embodiments are not intended to limit the scope of the present invention. Any equivalent modification or variation according to the spirit of the present invention is to be also included within the scope of the present invention.

What is claimed is:

1. A portable noninvasive inspection device comprising:
 - a light source illuminating a target to generate an optical inspection signal;
 - a probe head providing an optical path for said light source to receive said optical inspection signal;
 - at least one switched filter module arranged in said optical path, allowing said optical inspection signal to pass there through to generate a corresponding spectral signal; and
 - an image sensor arranged behind said at least one switched filter module, receiving said spectral signal and generating a spectral image, said switched filter module being a movable-type switched filter module.
2. The portable noninvasive inspection device according to claim **1**, wherein said light source contains at least one light emitting diode or laser device.
3. The portable noninvasive inspection device according to claim **2**, wherein said light source contains a plurality of light emitting diodes or laser devices arranged annularly.
4. The portable noninvasive inspection device according to claim **1**, wherein said switched filter module is arranged inside said probe head, and one of said filters is exactly aligned to said optical path.

5. The portable noninvasive inspection device according to claim **1**, wherein said movable-type switched filter module includes a movable plate inserted into said probe head and having a plurality of positioning slots where said filters are inserted, and said movable plate is translated to switch said filters.

6. The portable noninvasive inspection device according to claim **1**, wherein said filters in said switched filter module are switched manually or automatically.

7. The portable noninvasive inspection device according to claim **1**, wherein said probe head includes a front probe head structure and a rear probe head structure; said front probe head structure and said rear probe head structure are assembled together with a penetrating space formed there inside to function as said optical path; said switched filter module is arranged between said front probe head structure and said rear probe head structure, and one of said filters is aligned to said optical path.

8. The portable noninvasive inspection device according to claim **1**, wherein said probe head is a connection ring; said switched filter module is arranged inside said connection ring, and said image sensor is arranged behind said connection ring.

9. The portable noninvasive inspection device according to claim **8**, wherein said light source is arranged inside said connection ring and in a perimeter of said optical path between said switched filter module said image sensor.

10. The portable noninvasive inspection device according to claim **1** further comprising a probe tube installed in a front end of said probe head for providing a limited observation field.

11. The portable noninvasive inspection device according to claim **10**, wherein said observation field is 0.1 mm-10 cm.

12. The portable noninvasive inspection device according to claim **10** further comprising a hand-held body accommodating said image sensor and connected with said probe head.

13. The portable noninvasive inspection device according to claim **12** further comprising a battery module arranged inside said hand-held body, electrically connected with said light source and said image sensor and supplying power to said light source and said image sensor.

14. The portable noninvasive inspection device according to claim **12** further comprising a wireless communication module arranged inside said hand-held body, electrically connected with said image sensor and transmitting said spectral image to an external device.

15. The portable noninvasive inspection device according to claim **10**, wherein said light source is arranged before or beside said probe tube.

16. The portable noninvasive inspection device according to claim **10**, wherein said probe tube is sand-blasted and blackened.

17. The portable noninvasive inspection device according to claim **1**, wherein a surface of said probe head is sand-blasted and blackened.

18. The portable noninvasive inspection device according to claim **1**, wherein said light source is arranged before or behind said switched filter module.

19. The portable noninvasive inspection device according to claim **1**, wherein said spectral image is a biomedical image, a fluorescent image or a spectrum-based image.

20. The portable noninvasive inspection device according to claim **19**, wherein said light source is an exciting light source for said target; said light source excites said target to

generate a fluorescent signal as said optical inspection signal;
said optical inspection signal is filtered by said switched filter
module; said image sensor receives said optical inspection
signal filtered and generates said fluorescent image.

* * * * *