

An Energy-Recycling (ER) Technique for Reducing Power Consumption of Field Color Sequential (FCS) RGB LEDs Backlight Module

Ming-Hsin Huang¹, Yueh-Chang Tsai¹, Shih-Wei Wang¹, Dian-Rung Wu¹, Ke-Horng Chen¹, and Chien-Yu Chen²

¹Department of Electrical and Control Engineering, National Chiao Tung University, Hsinchu, Taiwan,

²Industrial Technology Research Institute, Hsinchu, Taiwan, Email: khchen@cn.nctu.edu.tw

Abstract- A single driving module with field color sequential (FCS) LCD technology needs to dynamically switch output voltage between 40 V for 12 series G- and B- color LEDs and 26 V for 12 series R-color LEDs at related time cluster. Thus, an energy-recycling (ER) technology is proposed to accelerate voltage settling and save compressed energy when the driving voltage is pressed from 40 V to 26 V. Only one recycling capacitor and one Schottky diode are added into the power structure of synchronous boost converter for composing the proposed ER technology. A proposed energy-recycling mode (ERM) controller is plugged into a boundary current mode (BCM) controller to control energy delivering and recycling. The proposed ER technology was fabricated by TSMC 0.25 μm 2.5/5 V BCD process. Experimental results demonstrate fast and efficient tracking performance of driving voltage is achieved.

I. INTRODUCTION

Field color sequential (FCS) LCD technology not only efficiency reduces color breakup and motion blur effects but also raises color gamut to 110 % of NTSC. Moreover, FCS-LCD technique effectively reduces 40 % power consumption which compares with a Cold Cathode Fluorescent Lamp (CCFL) backlight module and reduces fabrication cost due to the remove of color filter in CCFL LCD panels [1]-[3]. Owing to that sequential primary colors of red (R), green (G), and blue (B) are alternately turned on in FCS-LCD technology, the image quality of FCS-LCD panel therefore depends on the switching time of three primary colors and penetration with relative lumens of liquid crystal pixel of the FCS-LCD backlight module. Since LEDs generally have a good color spectrum performance and high color saturation, FCS-LCD technology can effectively expand the color gamut and provide high color saturation compared to conventional LCD technology. A comparison of LCD backlight technologies summarizes and shows in Table I.

The timing diagram of an image frame of FCS-LCD technology is shown in Fig. 1. It can be divided into three sub-frames of primary colors which are *sub-frame_R*, *sub-frame_G*, and *sub-frame_B* during a scanning frequency of 60 Hz. The detail operation of each sub-frame includes three operating steps. The first step is the video decoder decodes color data of image frame into primary colors and addresses related LCD pixels within 1.5 ms. The liquid crystal pixels then rotates to a corresponding angular position within 2 ms. The rest 2 ms is left for LED emission. The forward voltage,

TABLE I. COMPARISON OF LCD BACKLIGHT TECHNIQUES [1]

	RGB LEDs	White LEDs	CCFL
Saturation	Better	Poor	Medium
Color Gamut	110% NTSC	70~80% NTSC	60% NTSC
Lighten eff.	15~20 lm/W	15~20 lm/W	60~80 lm/W
Cost	High	Medium	Low
Startup	Need not warm-up	Need not warm-up	Need warm-up
Life	Long	Long	Short
Power Consumption	High	Low	Medium
Uniformity	Poor	Poor	Better

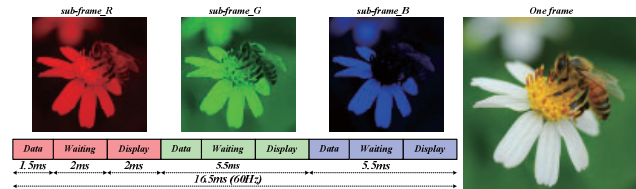

Fig. 1. The scanning sub-frame and related timing of FCS-LCD technology.

V_F of G- and B- LEDs is about 3.3 V. On other hand, V_F of R-LED is 2.2 V. Thus, two distinct driving voltages from different driving modules are needed. In order to reduce the volume and power consumption of driving system, a single driving module was proposed to efficiently switch the driving voltage between 40 V and 26 V for 12-series different color LEDs in the FCS-LCD technology. A reference tracking and fast transient technique in [4]-[5] was demonstrated for the dynamical driving voltage scaling.

However, in order to furthermore simplify the driving module and reduce more power consumption of the FCS-LCD backlight module, an energy-recycling (ER) technology is proposed. Since the driving module frequently switches the driving voltage from 40 V to 26 V, the stored charge of the output capacitor conventionally is consumed by output load and feedback resistors. A long settling time is needed to stabilize the driving voltage especially at the duration of data decoding and LCD rotating. The ER-technology is proposed to recycle the compressed charge from the driving output to an additional recycling capacitor C_R . The recycling capacitor C_R and one additional Schottky diode D_R compose the power structure of proposed ER technology. For properly controlling the delivering and recycling energy with minimum losses in

proposed ER technology, the boundary current mode (BCM) and proposed energy-cycling mode (ERM) controller are used to simplify the bidirectional energy control. Therefore, the ER-technology not only simplifies the power structure and control circuit but also increases performance and reduces the volume of driving module. The organization of this paper is Section II describes the structure and behavior of proposed ER technology. Section III describes the implementation of ER controller. Section IV shows experimental results. Finally, a conclusion is made in Section V.

II. THE STRUCTURE AND BEHAVIOR OF ER TECHNOLOGY

The structure of proposed ER technology as depicted in Fig. 2 is based on a BCM synchronous boost converter with a commercial high-side driver. The synchronous boost converter is composed of transistors M_L and M_H , parasitic diodes D_L and D_H , inductor L_m , output capacitor C_O , and feedback resistors R_1 and R_2 . The highlight components in Fig. 2 are the Schottky diode D_R and the recycling capacitor C_R that constitute the proposed structure of proposed ER technology. In order to simplify the bidirectional current sensing circuit in the zero-current detection (ZCD) circuit, the sensing resistor R_{SEN} , conventionally in series with transistor M_L , connects in series with the inductor L_m . Therefore, zero current can be easily detected by the crossover voltage of the resistor, R_{SEN} . Resistors R_P and R_N are used to clamp the feeding voltage of ER controller since a high voltage appears at the terminals of the resistor R_{SEN} . The commercial high-side driver is used to provide synchronous gate driving signal of transistors M_L and M_H . It generates reverse driving signals G_H and G_L with a dead-time control. The enable input, EN , of high-side driver is used to fully turn off the high- and low-side transistors at the same time. Therefore, the simplest design of proposed ER controller focuses on the combination of the BCM control for boost converter and the energy-recycling mode (ERM) controller for energy recycling. Since the additional Schottky diode D_R and the recycling capacitor C_R form an energy tank and connect with the main energy delivering path, the behavior of the proposed ER technology can be expanded into four phases as shown in Fig. 3. The detail behavior of each phase is described as follows.

A. Boosting Mode (BTM)

The basic operating mode of ER technology is boosting mode (BTM) which boosts driving voltage to specific voltage level for the requirement of LEDs. During BTM operating, the ER technology works as a synchronous boost converter. The Schottky diode D_R and capacitor C_R work as a filter. A BCM control is used to simplify the control loop. Transistor M_L is turned on by the zero-current condition and turned off by the on-time, T_{ON} , control. The peak inductor current level, I_{PEAK} , can be calculated by (1).

$$I_{PEAK} = \frac{V_R}{L_m} \quad (1)$$

where V_R is the voltage on the recycling capacitor C_R . The on-time, T_{ON} , of transistor M_L accords with feedback error-amplifier which monitors the driving voltage V_O and does not limited by maximum on-time, T_{ONMAX} , for clamping peak inductor current level, I_{PEAK} . Since a transconductance-

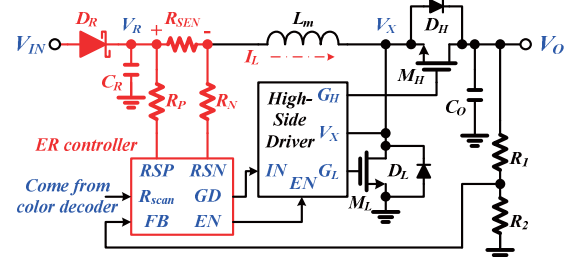

Fig. 2. The proposed structure of ER technology.

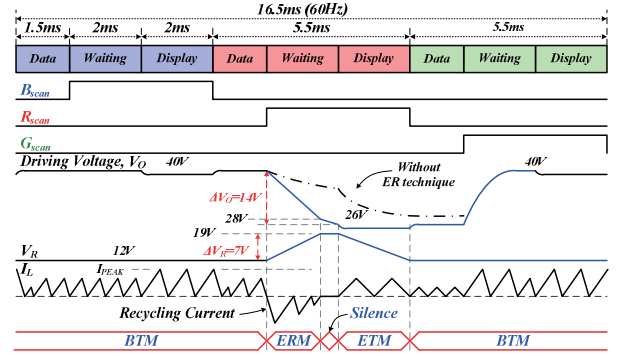

Fig. 3. The behavior of the ER technology.

amplifier is applied to monitor the specific driving power of FCS-LCD backlight module, a constant on-time is achieved and the on-time, T_{ON} , for the specific driving power, the inductor, and the supply voltage can be calculated by (2).

$$T_{ON} = \frac{2P_O L_m}{V_R^2 \eta} \quad (2)$$

where η is the power conversion efficiency and P_O is the specific driving power. When the on-time, T_{ON} , of transistor M_L expires, transistor M_H is switched on to boost the driving voltage. When the zero-current condition is detected, the transistor M_L is turned on again for the next switching cycle.

B. Energy-Recycling Mode (ERM)

Once the color decoder detects next sub-frame is R-color, the ERM is triggered by the color signal R_{scan} and the ZCD signal. The ER controller starts to recycle the pressed charge of output capacitor C_O to the recycling capacitor C_R . Since the direction of inductor current, I_L , becomes reverse direction, the proposed ERM controller is enabled to instead of the BCM controller. In order not to increase the complexity of the ER-controller, a fixed on-time, T_{ONFIX} , control is used to simplify the ER controller. When ERM is triggered, the ER controller keeps transistor M_H at on state until the fixed on-time, T_{ONFIX} , expires. At this time, the reverse current, I_L , appears in the inductor L_m . Since the reverse current stores on the capacitor C_R and increases the value of V_R , V_R will be larger than V_{IN} and the Schottky diode D_R can disconnect the path to the supply voltage. When the fixed on-time expires, transistor M_H turns off and transistor M_L turns on for releasing the reverse inductor current. The inductor current rises from negative to zero current. Once the zero current condition is detected, the transistors M_H are turned on again for initialing the next recycling cycle. Since the reverse current is stored by the recycling capacitor C_R , the voltage, V_R , increases higher

than, V_{IN} . A limitation voltage, V_R , of the ER technology must be smaller than the driving voltage, V_O . Therefore, the relationship between the pressed voltage, ΔV_O , and the rising voltage, ΔV_R , on the recycling capacitor C_R is expressed as (3) according to the voltage second balance principle. The value of C_R can be calculated by the boundary condition of (4) to avoid the critical limitation of ER technology.

$$\Delta V_O C_O = \Delta V_R C_R \quad (3)$$

$$V_{R(BTM)} + \Delta V_O \left(1 + \frac{C_O}{C_R}\right) < V_{O(BTM)} \quad (4)$$

C. Silence Mode

When the driving voltage, V_O , drops to 110 % of the driving voltage of 12-series R-LEDs, the ER-controller disconnects from the ERM controller and turns to connect to the BTM controller with the BCM control. At this time the driving voltage is still higher than the specific voltage, the feedback transconduction amplifier clamps a very small on-time, which will cause a high switching frequency and losses. A silence mode is used to fully turn off the switching signal until the driving voltage drops to the specific voltage level. The silence mode is also applied to BTM for ultra-light load condition. Therefore, an over voltage comparator is used to control the enable signal, EN , of the high-side driver. When the occurrence of over voltage condition means that the delivering energy is high enough, the gate driving signals fully turn off until the driving voltage, V_O , is lower than the over voltage level again.

D. Energy-Transferring Mode (ETM)

Once the driving voltage, V_O , drops to the specific voltage of the R-color LEDs, the converter stops the silence mode and switches to the energy-transferring mode (ETM). In the beginning, the storage charge boosts the driving voltage, V_O , for the R-color LEDs. Then, the BCM controller properly delivers the storage charge to the driving terminal. When the voltage, V_R , on the recycling capacitor C_R is smaller than the supply voltage, V_{IN} , the ETM expires and the converter starts to draw out energy from supply terminal, V_{IN} . It means that the storage charge is fully transferred to the driving terminal and the ER-controller switches to the BTM operation.

III. IMPLEMENTATION OF THE ER CONTROLLER

According to the ER's behavior, the block diagram of ER controller is shown in Fig. 4. A transconduction amplifier (OTA) can monitor the driving voltage and its output signal, V_{EA} , compares with a timing signal, $Ramp$, to determine the on-time, T_{ON} , of the transistor M_L . A constant current, I_T , is used to charge the timing capacitor C_M to generate the timing signal, $Ramp$, and the maximum on-time, T_{ONMAX} . If the high state period of T_{ONMAX} , is shorter than that of T_{ON} , the on time of transistor M_L is limited by T_{ONMAX} , which can be defined as (5).

$$T_{ONMAX} = C_M \times R_T \times V_{Schmitt} \quad (5)$$

$1/R_T$ is the conversion ratio of the voltage-to-current circuit. $V_{Schmitt}$ is the trigger voltage of the Schmitt trigger. Alternatively, stability and accuracy results can be got by a

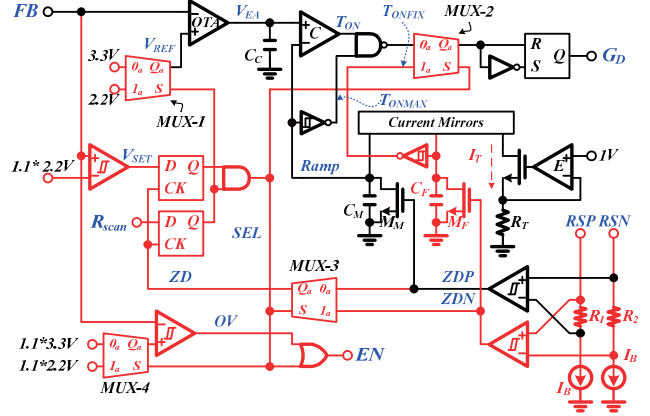

Fig. 4. The block diagram of ER controller.

comparator with a reference voltage. Another timing capacitor C_F is used to generate fixed on-time, T_{ONFIX} , for the ERM operation. Similar to the maximum on-time circuit, the fixed on-time, T_{ONFIX} , can also be defined as (6).

$$T_{ONFIX} = C_F \times R_T \times V_{Schmitt} \quad (6)$$

The sensing resistor R_{SEN} and the clamping resistors R_P and R_N compose the zero-current circuit as shown in Fig. 2. The sensing circuit of the ER controller directly senses the voltage polarization of input terminals RSP and RSN . If the voltage at terminal RSP is larger than that at terminal RSN , the inductor current is higher than the zero current and then the output, ZDP , of the positive ZCD circuit is set to low. Once the zero current happens, the voltage at terminal RSN will be larger than that at terminal RSP . ZDP changes to high for resetting the timing capacitor C_M and initialing the next switching cycle. A reverse signal, ZDN , of negative ZCD circuit is used to control the zero current condition at the ERM operation. The signals ZDP and ZDN are used to synchronous the R-color signal, R_{scan} , and disable the signal, V_{SET} . During G- or B-color operation, the R-color signal, R_{scan} , stays at low and therefore the selecting signal, SEL , is set to low. The ER controller operates at the BTM or ETM operation. Thus, reference voltage, V_{REF} , is set to 3.3 V and the driving signal, G_D , is controlled by on-time, T_{ON} , or maximum on-time, T_{ONMAX} . The output, ZDP , of positive ZCD circuit is selected. The driving voltage, V_O , will be regulated at 40 V for G- or B-color LEDs and signal, V_{SET} , will be set to high. When the R-color signal, R_{scan} , changes to high, the ER mode is enabled. The voltage reference, V_{REF} , is set to 2.2 V, the output, ZDN , of negative ZCD circuit is selected and driving signal, G_D , is controlled by fixed on-time, T_{ONFIX} , which is used to control the on-time of transistor M_H . Furthermore, the propagation delay of the ZCD loop and offset of comparators will cause an undesirable reverse inductor current. Therefore, an offset circuit composed of the resistors R_1 and R_2 and shown in Fig. 4 is inserted into the positive and negative ZCD circuit to adjust the inductor current level.

IV. EXPERIMENTAL RESULTS

The proposed ER technology for FCS-LCD backlight module was fabricated by TSMC 0.25 μm 2.5/5 V BCD

process. Chip micrograph of ER controller is shown in Fig. 5. The chip size is $800 \times 1100 \mu\text{m}^2$. The supply voltage, V_{IN} , of the ER controller is 12~20 V. The ER controller boosts the supply voltage, V_{IN} , up driving voltage, V_O , to 40 V for 12 series G- or B-LEDs and 26 V for 12 series R-LEDs. Besides, the voltage, V_R , on recycling capacitor C_R is limited under 20 V by the calculation of (3) and (4). The performance and response of the voltage scaling is shown in Fig. 6 with a dummy load of 5 W. The driving voltage, V_O , is dynamically stepped up to 40 V and 26 V according to the R-color signal, R_{scan} , which is generated by the color decoder. When the color signal, R_{scan} , is low, the driving voltage, V_O , boosts to 40 V. The settling time of 40 V is 300 μs as shown in Fig. 7. Once the color signal, R_{scan} , changes to high, the ERM is enabled. The driving voltage rapidly drops to 28 V and the pressed energy stores into capacitor C_R as shown in Fig. 8. As the analysis results, the reverse current is measured during the ERM operation. Since the ER technology is achieved, the maximum power conversion efficiency of the proposed ER technology ramps up to 94 %. Table II summarizes the design parameters and the measurement results.

V. CONCLUSIONS

The FCS-LCD backlight module with the ER technology is proposed to provide high power conversion efficiency and reduces fabrication cost. The proposed ER structure and controller rapidly switch the driving voltage between 40 V and 26 V for 12-series different color LEDs. The recycling capacitor C_R properly acts an energy tank to recycle the pressed charge when the driving voltage scales down to 26 V. Without energy wasting, the recycling charge transfers to the output terminal again for the backlight module. The experimental results show 94 % conversion efficiency.

REFERENCES

- [1] Y. F. Chen, C. C. Chen, and K. H. Chen, "Mixed Color Sequential Technique for Reducing Color Breakup and Motion Blur Effects," *IEEE/OSA Journal of Display Technology*, pp. 377-385, Dec., 2007.
- [2] S. Hong, et. al., "Advanced Method for MotionBlur Reduction in LCDs," *Society for Information Display*, pp. 466-469, 2005.
- [3] K. H. Shin, et. al., "Acceptable Motion Blur Levels of a LCD TV Based on Human Visual System," *Society for Information Display*, pp. 287-290, 2006.
- [4] C. Y. Hsieh, and K. H. Chen, "Boost DC-DC converter with charge-recycling (CR) and fast reference tracking (FRT) techniques for high-efficiency and low-cost LED driver," *IEEE European Solid-State Circuits Conference*, pp. 358 - 361, Sept., 2008.
- [5] C. Y. Hsieh, C. Y. Yang, M. H. Huang, D. H. Li, C. L. Chen, and K. H. Chen, "A Charge-Reservoir with Buck-Store and Boost-Restore (BSBR) Technique for High Efficient Conversion and Low Cost Solution of RGB LED Display Panels," *Society for Information Display*, 2009, in press.

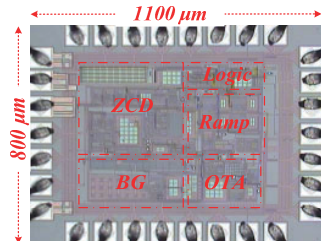

Fig. 5. Chip micrograph of the proposed ER controller.

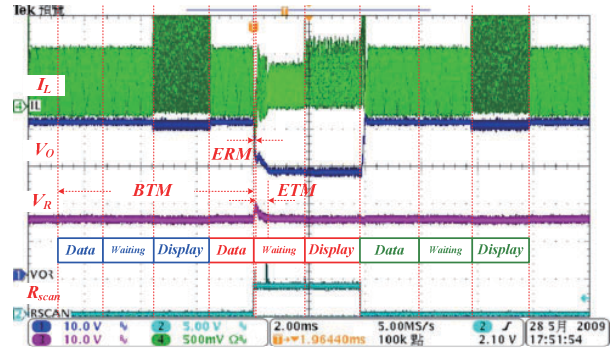

Fig. 6. The measurement waveform of ER technology with a 5 W dummy load.

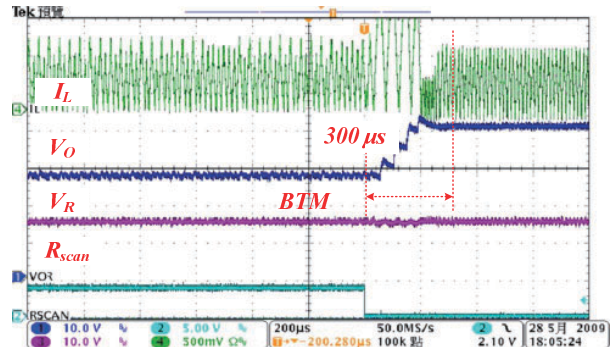

Fig. 7. The rising waveform of ER technology at BTM operation.

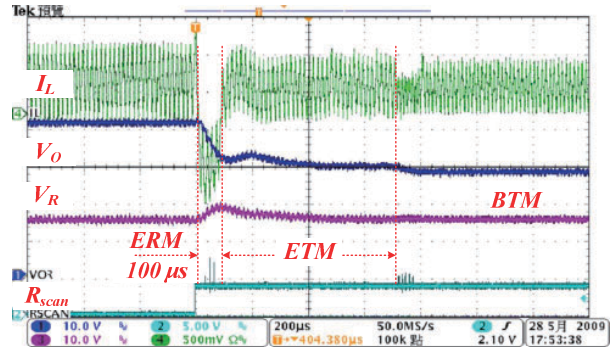

Fig. 8. The falling waveform of ER technology at ERM, silence mode and ETM operation.

TABLE II. MEASUREMENT PERFORMANCE OF THE ER-SYSTEM

Parameter	Value
Fabrication Process	0.25 μm 2.5/5 V BCD process
Inductor (μH)/ Sensing Resistor	100 μH / 0.1 Ω
C_O / C_R (μF)	2.2 μF / 10 μF
Maximum Output Power (W)	5 W
Input Voltage (V_{IN})	12~20 V
Output Voltage (V_O)	40 V for G- and B- colors 26 V for R-Color
Output Settling Time (T_{set})	300 μs / 100 μs
Switching Frequency (Hz)	70 kHz for 40 V output 50 kHz for 26 V output
Output Ripple	$\pm 5\%$
Efficiency (%)	94 %