



US 20170057847A1

(19) **United States**

(12) **Patent Application Publication**
Huang et al.

(10) **Pub. No.: US 2017/0057847 A1**

(43) **Pub. Date: Mar. 2, 2017**

(54) **COMPOSITE WATER PURIFICATION APPARATUS AND METHOD THEREOF**

Publication Classification

(71) Applicant: **National Chiao Tung University,**
Hsinchu (TW)

(51) **Int. Cl.**
C02F 1/467 (2006.01)
C02F 1/32 (2006.01)
C02F 1/72 (2006.01)
(52) **U.S. Cl.**
CPC *C02F 1/4672* (2013.01); *C02F 1/725*
(2013.01); *C02F 1/325* (2013.01); *C02F*
2201/32 (2013.01); *C02F 2305/10* (2013.01)

(72) Inventors: **Chih-Pin Huang,** Hsinchu (TW);
Chien-Hung Chen, Taiwan (TW);
Hsin-Ju Yang, Taiwan (TW);
Chi-Chang Hu, Taiwan (TW);
Wei-Chieh Lin, Taiwan (TW)

(57) **ABSTRACT**

A composite water purification apparatus and method thereof are provided. The composite water purification apparatus includes a container, a sacrificial anode, a photocatalyst anode and a cathode. The container is employed for receiving liquid including water and gas. The photocatalyst anode includes a photocatalyst for conducting a photocatalytic reaction. The cathode is electrolyzed with the sacrificial anode and the photocatalyst anode. The cathode, the sacrificial anode, and the photocatalyst anode are immersed in the container to contact the liquid. The present invention enhances the purity of the water, while prolonging the service life of the sacrificial anode.

(21) Appl. No.: **15/207,701**

(22) Filed: **Jul. 12, 2016**

(30) **Foreign Application Priority Data**

Aug. 28, 2015 (TW) 104128284

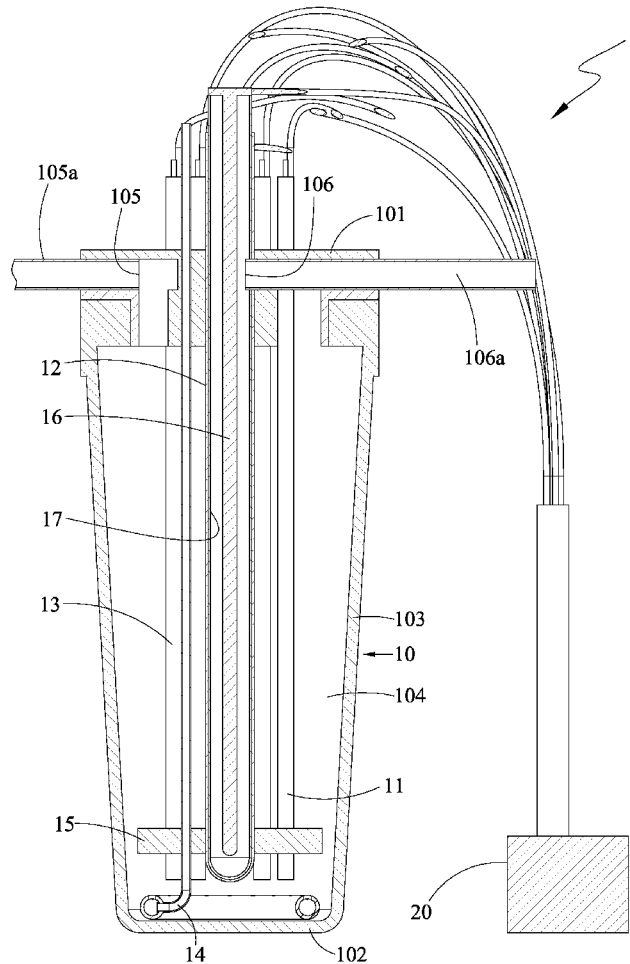

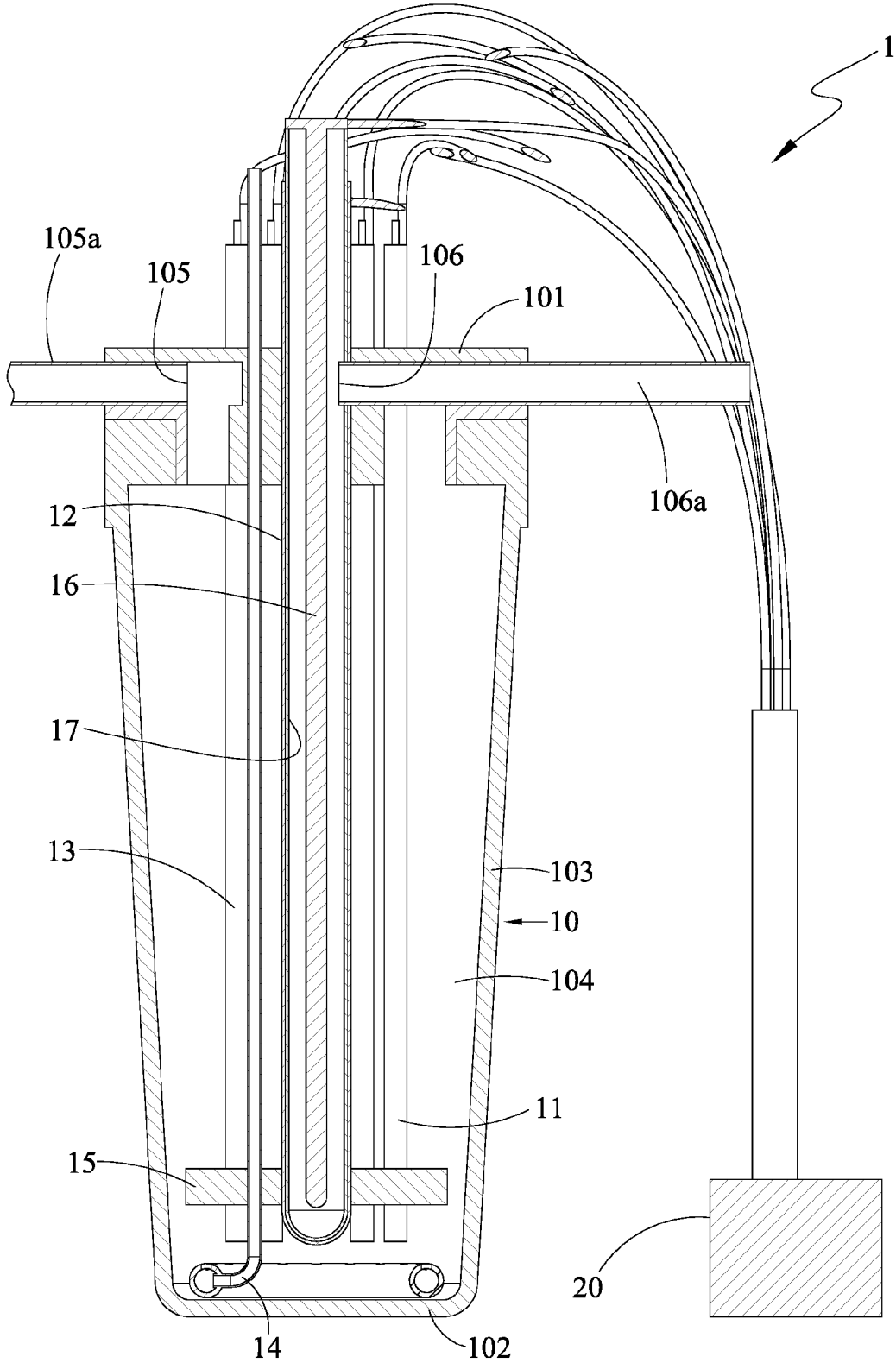

FIG. 1

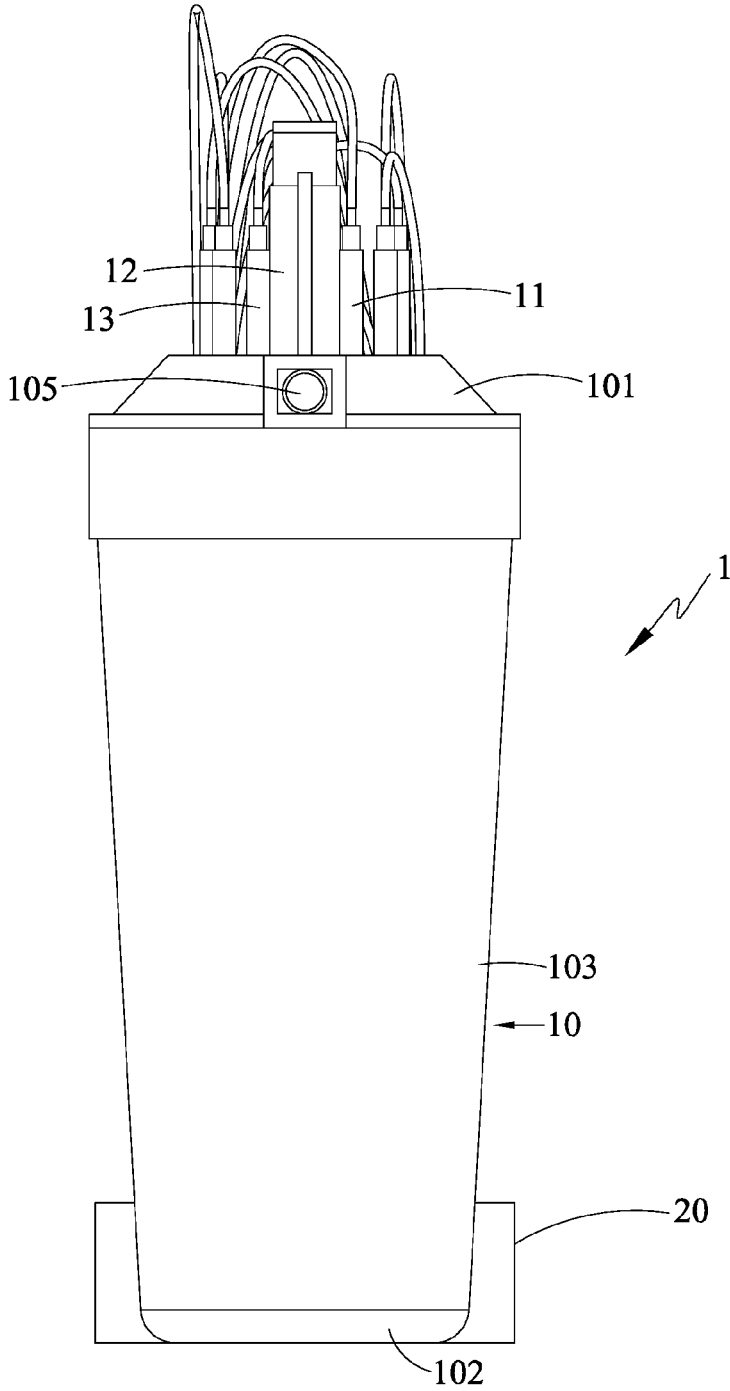

FIG. 2

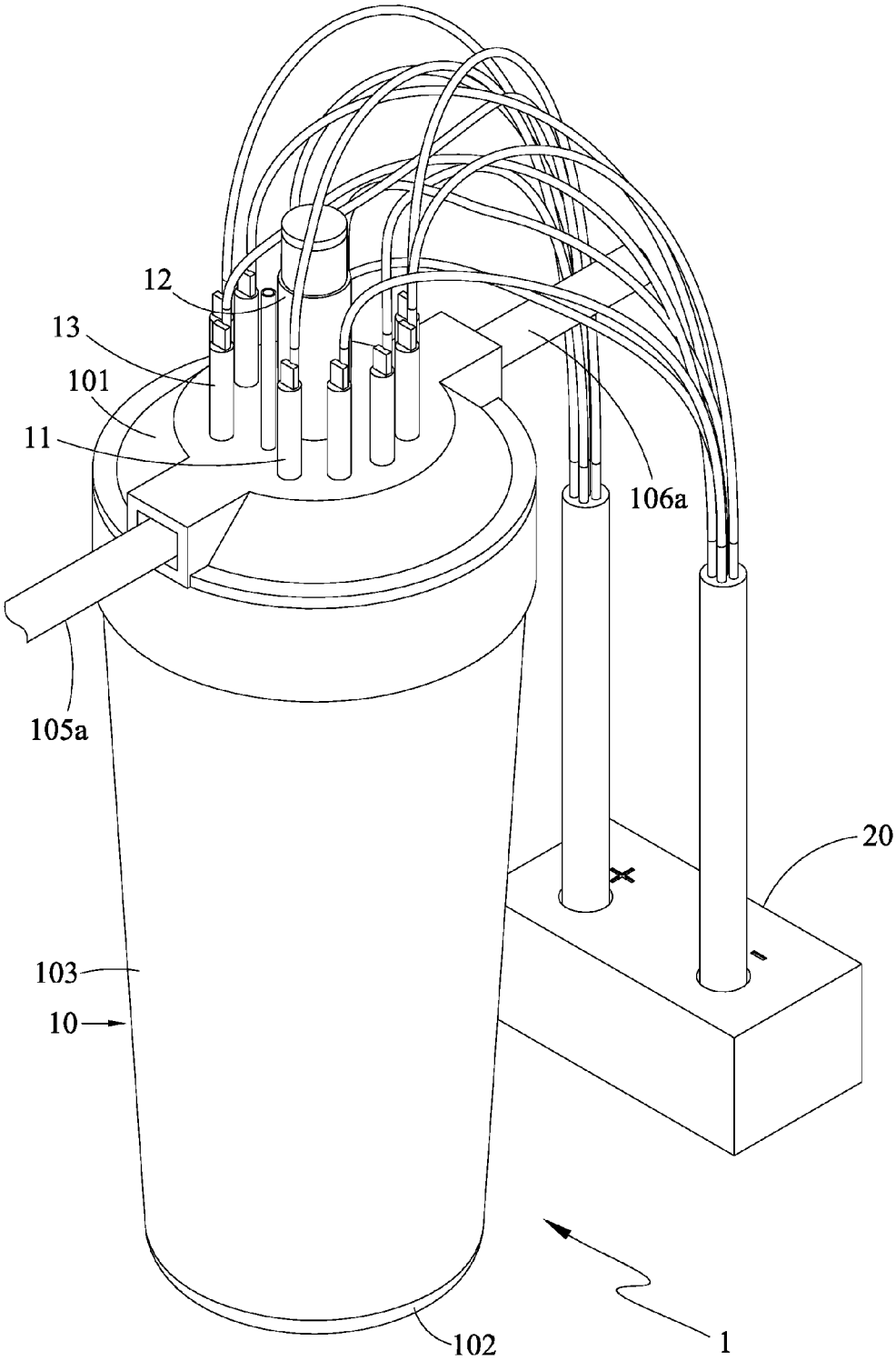

FIG. 3

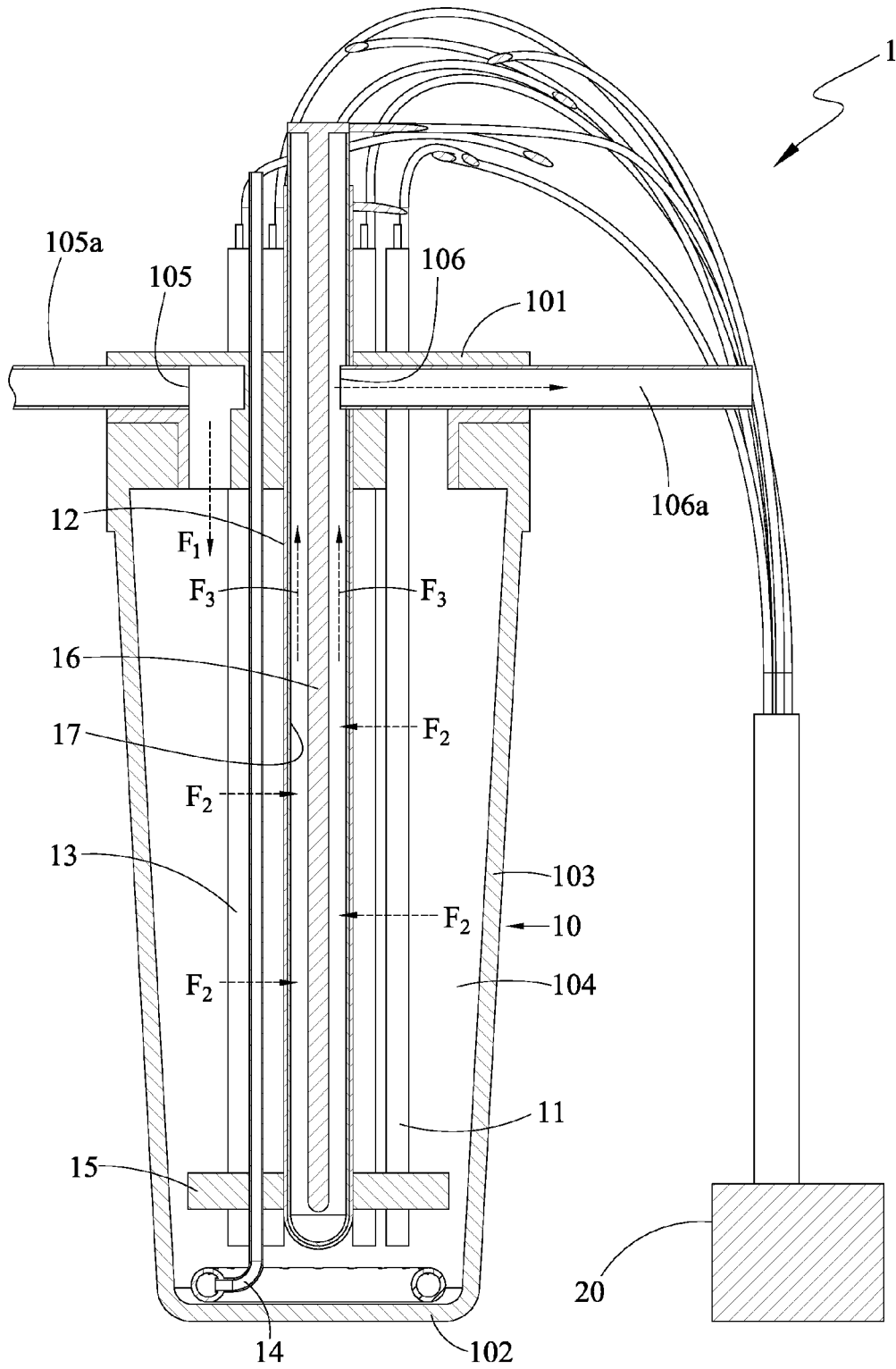

FIG. 4

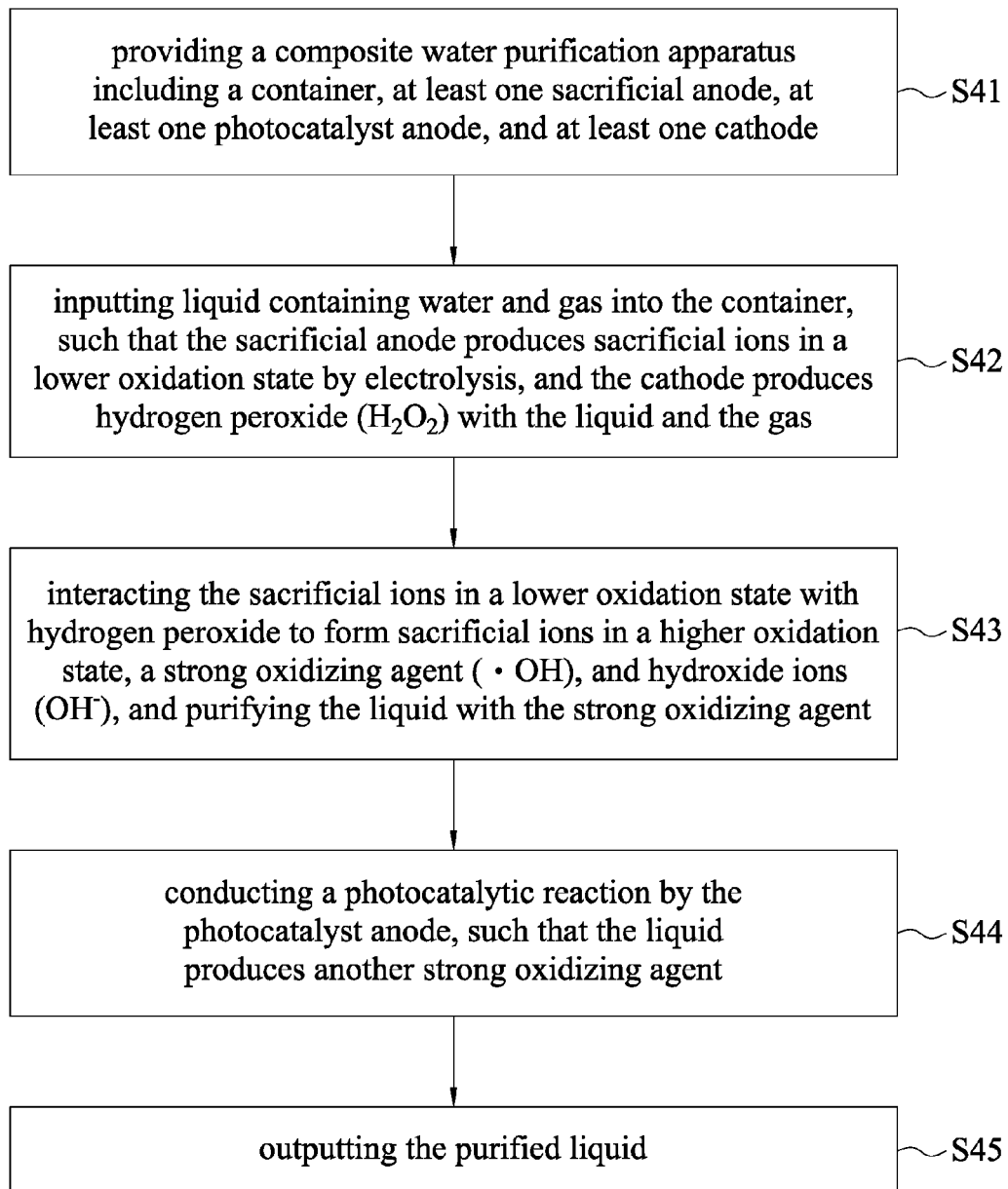

FIG. 5

COMPOSITE WATER PURIFICATION APPARATUS AND METHOD THEREOF

BACKGROUND OF THE INVENTION

[0001] 1. Field of the Invention

[0002] The present invention relates to composite water purification techniques, and, more particularly, to a composite water purification apparatus and method thereof that immerse a sacrificial anode, a photocatalyst anode and a cathode in the same container.

[0003] 2. Description of Related Art

[0004] In the field of modern water treatment technology, the photocatalyst purification unit and the electrolytic purification unit are traditionally placed in separate containers. As a result, in a single container having only the photocatalytic purification unit or the electrolytic purification unit, treated water can only be subjected to degradation once. The performance would be substantially improved if degradation can happen more than once in a single container.

[0005] Further, since the photocatalyst contained the traditional photocatalytic purification unit is not electrically coupled to a power supply, after the photocatalyst produces strong oxidizing agents (e.g., electron holes and hydroxyl radicals), the strong oxidants and the excited electrons separated by light are often recombined, thereby significantly reducing the amount of strong oxidants produced.

[0006] Therefore, there is a need for a solution that addresses the issues associated with the photocatalyst purification unit and the electrolysis purification unit being placed in separate containers and the photocatalyst in the photocatalyst purification unit not electrically coupled to a power supply in the prior art.

SUMMARY OF THE INVENTION

[0007] In view of the aforementioned shortcomings of the prior art, the present invention provides a composite water purification apparatus, which may include: a container for receiving a liquid including water and gas; at least one sacrificial anode; at least one photocatalyst anode including a photocatalyst for conducting a photocatalytic reaction to purify the liquid; and at least a cathode electrolyzed with the sacrificial anode and the photocatalyst anode, wherein the sacrificial anode, the photocatalyst anode, and the cathode are immersed in the container to contact the liquid.

[0008] The present invention further includes a composite water purification method, which may include the following steps of: a) providing a composite water purification apparatus including a container, at least one sacrificial anode, at least one photocatalyst anode, and at least one cathode, wherein the photocatalyst anode includes a photocatalyst, and the sacrificial anode, the photocatalyst anode, and the cathode are immersed in the container; b) inputting a liquid including water and gas into the container, such that a photocatalytic reaction is conducted at the sacrificial anode, the sacrificial anode produces sacrificial ions in a lower oxidation state, and the cathode produces hydrogen peroxide (H_2O_2) by using the liquid and the gas; c) interacting sacrificial ions in a lower oxidation state with hydrogen peroxide to form sacrificial ions in a higher oxidation state, a strong oxidizing agent ($\cdot OH$), and hydroxide ions (OH^-), the strong oxidizing agent purifying the liquid; d) conducting a photocatalytic reaction, by the photocatalyst anode,

such that the liquid produces another strong oxidizing agent ($\cdot OH$); and e) outputting the purified liquid.

[0009] Therefore, by immersing the sacrificial anode, the photocatalyst anode, and the cathode all in the same container, the purification process of the liquid is enhanced. Besides, the present invention allows the sacrificial ions in a higher oxidation state to be reduced back to a lower oxidation state at the cathode, thus prolonging the life of the sacrificial anode.

BRIEF DESCRIPTION OF THE DRAWINGS

[0010] FIG. 1 is a cross-sectional view of a composite water purification apparatus in accordance with the present invention;

[0011] FIG. 2 is a lateral view of a composite water purification apparatus in accordance with the present invention;

[0012] FIG. 3 is a perspective view of a composite water purification apparatus in accordance with the present invention;

[0013] FIG. 4 is a cross-sectional view depicting the direction of the liquid flow when a composite water purification apparatus in accordance with the present invention is in operation; and

[0014] FIG. 5 is a flowchart illustrating the steps of a composite water purification method in accordance with the present invention.

DETAILED DESCRIPTION OF THE EMBODIMENTS

[0015] The present invention is described by the following specific embodiments. Those with ordinary skills in the arts can readily understand other advantages and functions of the present invention after reading the disclosure of this specification. The present disclosure may also be practiced or applied with other different implementations. Based on different contexts and applications, the various details in this specification can be modified and changed without departing from the spirit of the present disclosure.

[0016] FIG. 1 is a cross-sectional view of a composite water purification apparatus 1 in accordance with the present invention. FIG. 2 is a lateral view of the composite water purification apparatus 1 in accordance with the present invention. The composite water purification apparatus 1 includes a container 10, at least one sacrificial anode 11, at least one photocatalyst anode 12, and at least one cathode 13.

[0017] The container 10 is used for receiving liquid including water and gas. The photocatalyst anode 12 includes a photocatalyst for conducting a photocatalytic reaction for purifying the liquid. The cathode 13 is used in conjunction with both the sacrificial anode 11 and the photocatalyst anode 12 for electrolysis. The sacrificial anode 11, the photocatalyst anode 12, and the cathode 13 are all immersed in the container to be in contact the liquid.

[0018] In an embodiment, the container 10 includes a top part 101, a bottom part 102 opposite to the top part 101, and a lateral part 103 connecting the top part 101 and the bottom part 102, and the top part 101, the bottom part 102, and the lateral part 103 constitute a chamber 104 for receiving the liquid including water and gas (i.e., water including gas dissolved therein).

[0019] Furthermore, the container **10** has an inlet **105** and an outlet **106**. In an embodiment, the top part **101** and the lateral part **103** may be formed integrally. Alternatively, the top part **101** may be a lid that fits with the lateral part **103**, and the inlet **105** and the outlet **106** may be disposed at any positions of the container **10**, depending on the needs. In an embodiment, the inlet **105** and the outlet **106** may be positioned on the top part **101**. The inlet **105** may be further connected to an externally-connecting tube **105a**. The outlet **106** may be further connected to an externally-connecting tube **106a**. The tube **105a** or **106a** may be a pipe or a conduit.

[0020] The sacrificial anode **11** may be electrically coupled to a power supply **20** attached in or external to the composite water purification apparatus **1** via a wire in order for electrolysis to occur. In an embodiment, the sacrificial anode **11** may be made of iron or copper. Under the circumstance that the power supply **20** is providing power, the sacrificial anode **11** may produce sacrificial ions in a lower oxidation state with the liquid similar to the following chemical formula (1). For example, in the case that the sacrificial anode **11** is made of iron or copper, the sacrificial ions in a lower oxidation state may be ions in an oxidation state of +2 (Fe^{2+}) or +1 (Cu^+). The following chemical formula (1) is exemplified with iron as the sacrificial anode **11**:



[0021] The cathode **13** may be also electrically coupled to the power supply **20** attached in or external to the composite water purification apparatus **1** via a wire in order for electrolysis to occur. In an embodiment, the cathode **13** is made of a material containing carbon. The sacrificial anode **11** and the cathode **13** may be in the shapes of columns, sheets, strips, tubes, etc. Under the circumstance that the power supply **20** is providing power, the cathode **13** may produce hydrogen peroxide (H_2O_2) with the liquid similar to the following chemical formula (2).



[0022] After the sacrificial ions in a lower oxidation state and hydrogen peroxide are produced, the sacrificial ions in a lower oxidation state and hydrogen peroxide in the liquid may interact with each other, and produce sacrificial ions in a higher oxidation state, a strong oxidizing agent ($\cdot\text{OH}$) and hydroxide ions (OH^-) similar to the following chemical formula (3). The strong oxidizing agent can purify the liquid by degrading the liquid once. For example, if the sacrificial anode **11** is made of iron or copper, the sacrificial ions in a higher oxidation state are ions in an oxidation state of +3 (Fe^{3+}) or +2 (Cu^{2+}). The following chemical formula (3) is exemplified with iron as the sacrificial anode **11**:



[0023] Since in the present invention the sacrificial anode **11** and the cathode **13** are disposed in the same chamber **104**, the sacrificial ions in a higher oxidation state may further be reduced back to sacrificial ions in a lower oxidation state at the cathode **13** similar to the following chemical formula (4), thereby providing more sacrificial ions in a lower oxidation state to undergo the chemical formula (3). As a result, the number of the sacrificial ions in a lower oxidation state required from the sacrificial anode **11** in the chemical formula (1) is reduced, the loss of the sacrificial anode **11** is decreased, and the service life of the sacrificial anode **11** is

extended. The following chemical formula (4) is exemplified with iron as the sacrificial anode **11**:

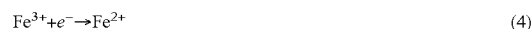

[0024] The photocatalyst anode **12** includes a photocatalyst. In an embodiment, the photocatalyst anode **12** includes a mesh substrate and a titanium dioxide (TiO_2) layer on the mesh substrate for conducting a photocatalytic reaction for purifying the liquid. In an embodiment, the mesh substrate can be a stainless steel mesh substrate or a titanium mesh substrate. Under external background light, the photocatalyst anode **12** may produce a strong oxidizing agent from the water-containing liquid similar to the following chemical formula (5), such that the liquid undergoes degradation for a second time. The following chemical formula (5) is exemplified with titanium dioxide photocatalyst anode **12**:

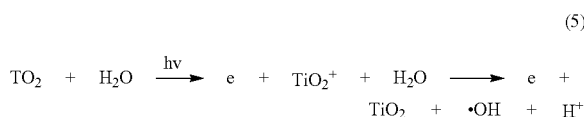

[0025] The photocatalyst anode **12** is electrically coupled to the power supply **20** via a wire, such that the strong oxidizing agent and the electrons produced from excitation by the external background light are pulled away from each other by the electrical field, thus reducing the occurrence of recombination and maintaining the quantity of the strong oxidizing agent.

[0026] In an embodiment, the composite water purification apparatus **1** according to the present invention further includes a light source **16** electrically coupled to the power supply **20** via a wire for facilitating a photocatalytic reaction of the photocatalyst anode **12**. The photocatalytic reaction of the photocatalyst anode **12** is strengthened by the light source **16**. In an embodiment, the light source **16** may be an ultraviolet (UV) lamp for facilitating photocatalytic reaction of the photocatalyst anode **12** that enhances the purification. With the UV lamp, the photocatalytic reaction of the photocatalyst anode **12** is strengthened. When the light source **16** is present, the composite water purification apparatus **1** further includes a light-transmissive element **17** that achieves an even irradiation of the light source **16**. The light-transmissive element **17** is positioned between the light source **16** and the photocatalyst anode **12**. Furthermore, when the light source **16** is present, the photocatalyst anode **12** may be positioned in such a way that it surrounds the light source **16**.

[0027] In an embodiment, the composite water purification apparatus **1** according to the present invention further includes an aeration element **14** disposed inside the chamber **104** of the container **10** for feeding additional gas into the liquid. The additional gas may be air or oxygen used in the chemical formula (2).

[0028] In an embodiment, the composite water purification apparatus **1** according to the present invention further includes a securing element **15** in the chamber **104** of the container **10** for holding the sacrificial anode **11**, the photocatalyst anode **12**, and the cathode **13** in place.

[0029] FIG. 3 is a perspective view of the composite water purification apparatus **1** in accordance with the present invention. In an embodiment, the inlet **105**, the sacrificial

anode **11** and the cathode **13**, the photocatalyst anode **12**, and the outlet **106** correspond to a position of the top part, and are arranged in an order from an outer rim to a center of the top part **101**.

[0030] In an embodiment, the sacrificial anode **11** and the cathode **13** are not limited to be positioned from the lateral part **103** by the same distance, as long as the distance of the set of the sacrificial anode **11** and the cathode **13** from the lateral part **103** is between that of the inlet **105** and that of the photocatalyst anode **12**. In other words, the arrangement of the various elements from the lateral part **103** may be as follows: the inlet **105**, the sacrificial anode **11**, the cathode **13**, the photocatalyst anode **12**, and the outlet **106**; or the inlet **105**, the sacrificial anode **11** and the cathode **13**, the photocatalyst anode **12**, and the outlet **106**; or the inlet **105**, the cathode **13**, the sacrificial anode **11**, the photocatalyst anode **12**, and the outlet **106**. The outlet **106** may be connected to a pump (not shown).

[0031] FIG. 4 is a cross-sectional view depicting the direction of the liquid flow when the composite water purification apparatus **1** in accordance with the present invention is in operation. As shown, the direction of the liquid flow going into the inlet **105** is indicated as F_1 , and the liquid undergoes chemical reactions at the sacrificial anode **11** and the cathode **13** in accordance with the above formulae (1) and (2). Before going through the photocatalyst anode **12**, the liquid undergoes a chemical reaction in accordance with formula (3), such that it is degraded for a first time. When going through the photocatalyst anode **12** (i.e., direction F_2), the liquid undergoes a chemical reaction in accordance with the formula (5), such that the liquid is degraded for a second time. Finally, the twice-degraded liquid is discharged from the outlet **106** (i.e., direction F_3). However, when the light source **16** is present, the outlet **106** may be positioned between the photocatalyst anode **12** and the light source **16**.

[0032] In another embodiment of the composite water purification apparatus **1** according to the present invention, in the case that the photocatalyst anode **12** includes a mesh substrate and a titanium dioxide layer, the mesh substrate allows the twice-degraded liquid to pass therethrough, and the outlet **106** may be positioned between the photocatalyst anode **12** and the set of the sacrificial anode **11** and the cathode **13**. In an embodiment, the outlet **106** is connected to a pump to help extract the twice-degraded liquid from the outlet **106** after it has passed through the photocatalyst anode **12**.

[0033] In still another embodiment of the composite water purification apparatus **1** according to the present invention, corresponding to the position of the top part **101**, the inlet **105**, the outlet **106**, the sacrificial anode **11**, the photocatalyst anode **12**, and the cathode **13** may be arranged from the rim towards the center of the top part **101** in another order as follows: the cathode **13**, the outlet **106**, the sacrificial anode **11**, the photocatalyst anode **12**, and the outlet **106**. The outlet **106** can be connected to a pump (not shown). As a result, the liquid entering the inlet **105** can undergo chemical reactions in accordance with the formulae (1) to (3) between the sacrificial anode **11** and the cathode **13** and before going through the photocatalyst anode **12**, such that the liquid is degraded for a first time. The liquid undergoes a chemical reaction in accordance with the formula (5) when passing through the photocatalyst anode **12**, such that the liquid is degraded for a second time. Finally, the twice-degraded

liquid is discharged from the outlet **106**. Moreover, when the light source **16** is present, the outlet **106** may be positioned between the photocatalyst anode **12** and the light source **16**. Furthermore, the outer surface of the cathode **13** facing the inner wall of the container **10** (i.e., the chamber **104**) can be hydrophobic, and the inner surface opposite to the outer surface may be hydrophilic.

[0034] FIG. 5 is a flowchart illustrating the steps of a composite water purification method in accordance with the present invention. The method employs the composite water purification apparatus **1** with respect to FIGS. 1 to 4 as mentioned earlier. The various components of the composite water purification apparatus **1** have already been discussed, further description hereby omitted. The composite water purification method may include steps S41 to steps S45.

[0035] In step S41, a composite water purification apparatus **1** including a container **10**, at least one sacrificial anode **11**, at least one photocatalyst anode **12**, and at least one cathode **13** is provided, wherein the photocatalyst anode **12** includes a photocatalyst, and the sacrificial anode **11**, the photocatalyst anode **12**, and the cathode **13** are all immersed in the container **10**. The sacrificial anode **11**, the photocatalyst anode **12**, and the cathode **13** are electrically coupled to a power supply **20** via wires, such that the power supply **20** provides power to the sacrificial anode **11** and the cathode **13** for electrolysis, and the power supply **20** also helps in removing electrons from the photocatalyst anode **12** isolated by the photocatalytic reaction.

[0036] In step S42, a liquid containing water and gas is inputted, such that the sacrificial anode **11** produces sacrificial ions in a lower oxidation state (i.e., the chemical formula (1) using iron as the sacrificial anode **11**) by electrolysis, and the cathode **13** produces hydrogen peroxide (H_2O_2) with the liquid and the gas (i.e., the chemical formula (2)).

[0037] In step S43, the sacrificial ions in a lower oxidation state and hydrogen peroxide interact with each other to form sacrificial ions in a higher oxidation state, a strong oxidizing agent ($\cdot OH$), and hydroxide ions (OH^-) (i.e., the chemical formula (3) using iron as the sacrificial anode **11**), and the strong oxidizing agent purifies the liquid. Moreover, after being formed in a higher oxidation state, the sacrificial ions are reduced back to sacrificial ions in a lower oxidation state at the cathode **13** (i.e., the chemical formula (4) using iron as the sacrificial anode **11**), thereby providing additional sacrificial ions in a lower oxidation state to the chemical formula (3), and reducing the number of the sacrificial ions in a lower oxidation state required from the sacrificial anode **11** in the chemical formula (1), thus decreasing the loss of the sacrificial anode **11** and extending the service life thereof.

[0038] In step S44, a photocatalytic reaction is conducted by the photocatalyst anode **12**, such that the liquid produces another strong oxidizing agent ($\cdot OH$) (i.e., the chemical formula (5)).

[0039] In step S45, the twice-purified liquid is outputted.

[0040] In the case that an aeration element **14** for providing additional gas to the liquid is provided in the chamber **104** of the container **10** of the composite water purification apparatus **1**, additional gas (air or oxygen) necessary in the chemical formula (2) is provided by the aeration element **14** to the liquid in step S42, such that the liquid and the additional gas produces hydrogen peroxide at the cathode **13**.

[0041] Compared to the prior art, by immersing the sacrificial anode, the photocatalyst anode, and the cathode all in the same container, the present invention allows the liquid to undergo degradation twice before being discharged, thereby enhancing the purification process of the liquid. Besides, the present invention allows the sacrificial ions in a higher oxidation state to be reduced back to a lower oxidation state at the cathode, thus reducing the number of the sacrificial ions in a lower oxidation state extracted from the sacrificial anode. The service life of the sacrificial anode is therefore extended.

[0042] The above embodiments are only used to illustrate the principles of the present invention, and should not be construed as to limit the present invention in any way. The above embodiments can be modified by those with ordinary skill in the art without departing from the scope of the present invention as defined in the following appended claims.

What is claimed is:

1. A composite water purification apparatus, comprising: a container for receiving a liquid including water and gas; at least one sacrificial anode; at least one photocatalyst anode including a photocatalyst for conducting a photocatalytic reaction to purify the liquid; and at least a cathode electrolyzed with the sacrificial anode and the photocatalyst anode to purify the liquid, wherein the sacrificial anode, the photocatalyst anode, and the cathode are immersed in the container to contact the liquid.
2. The composite water purification apparatus of claim 1, further comprising an aeration element provided in the container for feeding additional gas to the liquid, wherein the additional gas is air or oxygen.
3. The composite water purification apparatus of claim 1, wherein the photocatalyst anode includes a mesh substrate and a titanium dioxide layer on the mesh substrate.
4. The composite water purification apparatus of claim 1, wherein the sacrificial anode is made of iron or copper, and the cathode is made of a material including carbon.
5. The composite water purification apparatus of claim 1, further comprising a power supply electrically coupled to the photocatalyst anode, the sacrificial anode, and the cathode for conducting the electrolysis.
6. The composite water purification apparatus of claim 1, further comprising a light source electrically coupled to a power supply, wherein the light source and the photocatalyst anode conduct the photocatalytic reaction, and the light source is an ultraviolet (UV) lamp.
7. The composite water purification apparatus of claim 6, further comprising a light-transmissive element positioned between the light source and the photocatalyst anode.
8. The composite water purification apparatus of claim 1, wherein the container includes an inlet, an outlet, a top part, a bottom part, and a lateral part connecting the top and the bottom parts, the top part, the bottom part, and the lateral part constitute a chamber for receiving the liquid, and the inlet, the sacrificial anode and the cathode, the photocatalyst anode, and the outlet correspond to a position of the top part, and are arranged in an order from an outer rim to a center of the top part.
9. A composite water purification method, comprising the following steps of:

- a) providing a composite water purification apparatus including a container, at least a sacrificial anode, at least a photocatalyst anode, and at least a cathode, wherein the photocatalyst anode includes a photocatalyst, and the sacrificial anode, the photocatalyst anode, and the cathode are immersed in the container;
- b) inputting a liquid including water and gas into the container, such that a photocatalytic reaction is conducted at the sacrificial anode, the sacrificial anode produces sacrificial ions in a lower oxidation state, and the cathode produces hydrogen peroxide (H_2O_2) by using the liquid and the gas;
- c) interacting sacrificial ions in a lower oxidation state with hydrogen peroxide to form sacrificial ions in a higher oxidation state, a strong oxidizing agent (.OH), and hydroxide ions (OH^-), the strong oxidizing agent purifying the liquid;
- d) conducting a photocatalytic reaction, by the photocatalyst anode, such that the liquid produces another strong oxidizing agent (.OH); and
- e) outputting the purified liquid.

10. The composite water purification method of claim 9, wherein the composite water purification apparatus further comprises an aeration element disposed in the container, and the method, in step b), further comprises providing additional gas, by the aeration element, to the liquid, such that the liquid and the additional gas produce hydrogen peroxide at the cathode.

11. The composite water purification method of claim 9, wherein after the sacrificial ions in a higher oxidation state are formed in step c), the sacrificial ions in a higher oxidation state are reduced back to the sacrificial ions in a lower oxidation state at the cathode.

12. The composite water purification method of claim 9, wherein the photocatalyst anode includes a mesh substrate and a titanium dioxide layer on the mesh substrate.

13. The composite water purification method of claim 9, wherein the sacrificial anode is made of iron or copper, such that the sacrificial ions in a lower oxidation state are iron ions in an oxidation state of +2 (Fe^{2+}) or copper ions in an oxidation state of +1 (Cu^+), and the sacrificial ions in a higher oxidation state are iron ions in an oxidation state of +3 (Fe^{3+}) or copper ions in an oxidation state of +2 (Cu^{2+}).

14. The composite water purification method of claim 9, wherein the cathode is made of a material including carbon.

15. The composite water purification method of claim 9, wherein the sacrificial anode, the photocatalyst anode, and the cathode are electrically coupled to a power supply, such that that in step d) the power supply removes electrons isolated from the photocatalyst anode via the photocatalytic reaction.

16. The composite water purification method of claim 9, wherein the composite water purification apparatus further comprises a light source electrically coupled to a power supply, such that that in step d) the light source and the photocatalyst conduct the photocatalytic reaction.

17. The composite water purification method of claim 16, wherein the light source is an ultraviolet (UV) lamp, such that in step d) the light source and the photocatalyst conduct the photocatalytic reaction, and the composite water purification apparatus further comprises a light-transmissive element positioned between the light source and the photocatalyst anode.

18. The composite water purification method of claim 9, wherein the container includes an inlet, an outlet, a top part, a bottom part, and a lateral part connecting the top and the bottom parts, the top part, the bottom part, and the lateral part constitute a chamber for receiving the liquid, and the inlet, the sacrificial anode and the cathode, the photocatalyst anode, and the outlet correspond to a position of the top part, and are arranged in an order from an outer rim to a center of the top part.

* * * * *