



US 20180304077A1

(19) **United States**

(12) **Patent Application Publication**

Lee et al.

(10) **Pub. No.: US 2018/0304077 A1**

(43) **Pub. Date: Oct. 25, 2018**

(54) **COCHLEAR IMPLANT DEVICE AND STIMULATING METHOD THEREOF**

A61N 1/372 (2006.01)

H04R 25/00 (2006.01)

(71) Applicant: **NATIONAL CHIAO TUNG UNIVERSITY**, Hsinchu (TW)

(52) **U.S. CL.**

CPC *A61N 1/36038* (2017.08); *A61N 1/0541* (2013.01); *H04R 2225/67* (2013.01); *H04R 25/606* (2013.01); *H04R 25/554* (2013.01); *A61N 1/37229* (2013.01)

(72) Inventors: **Chia-Fone Lee**, Hsinchu City (TW); **Yuan-Fang Chou**, New Taipei City (TW); **Chung-Yu Wu**, New Taipei City (TW); **Ming-Dou Ker**, Zhubei City (TW); **Chung-Chih Hung**, Hsinchu City (TW); **Xin-Hong Qian**, Chiayi City (TW)

(57)

ABSTRACT

A cochlear implant device comprises a receiver, a processing device, a first electrode and a second electrode. The receiver is configured to receive outside voice signal. The processing device is coupled to the receiver, configured to receive and transfer the voice signal to an electrical stimulation signal. The first electrode connects to the processing device, disposed on stapes footplate ligament or oval window. The second electrode connects to the processing device, disposed on round window. Wherein the electrical stimulation signal is applied to stapes footplate ligament, oval window or round window to stimulate acoustic nerve through the first electrode or the second electrode.

(21) Appl. No.: **15/680,921**

(22) Filed: **Aug. 18, 2017**

(30) **Foreign Application Priority Data**

Apr. 21, 2017 (TW) 106113521

Publication Classification

(51) **Int. Cl.**

A61N 1/36 (2006.01)

A61N 1/05 (2006.01)

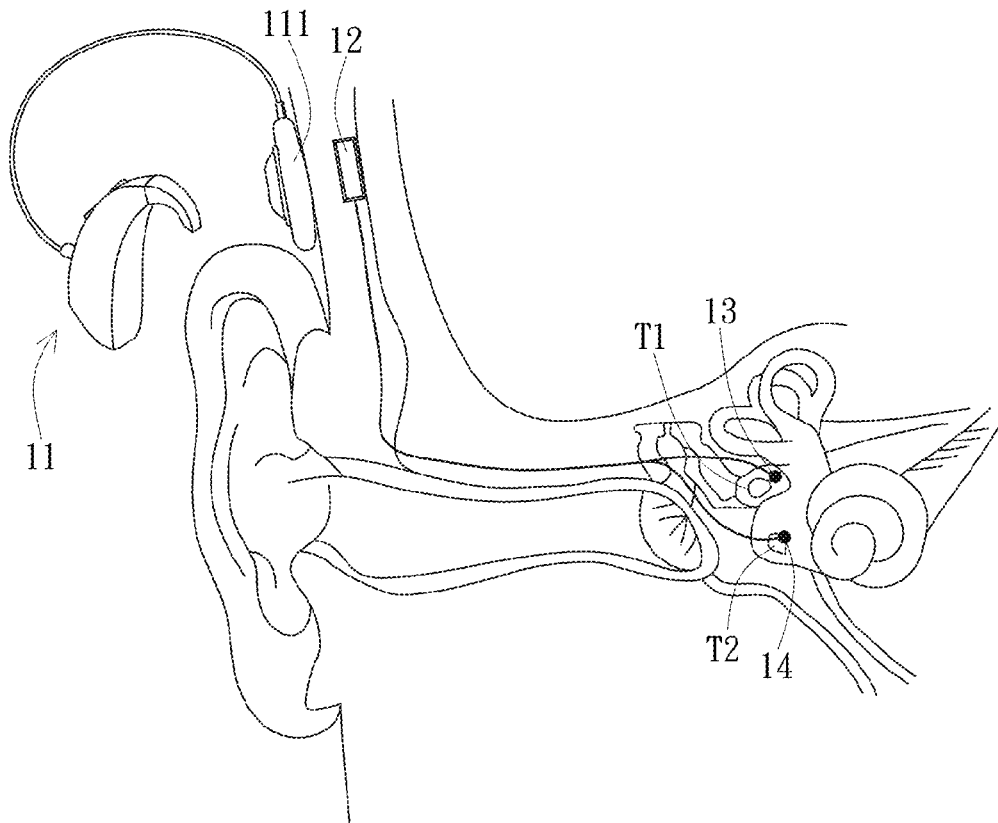

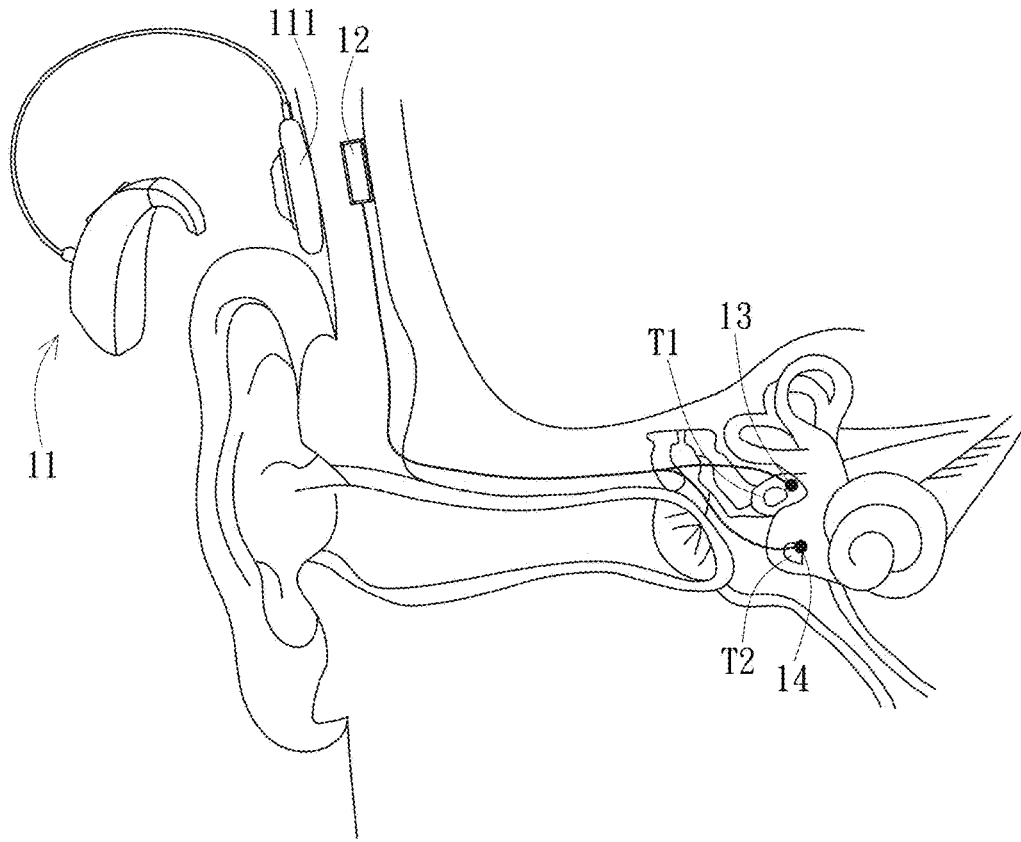

FIG. 1A

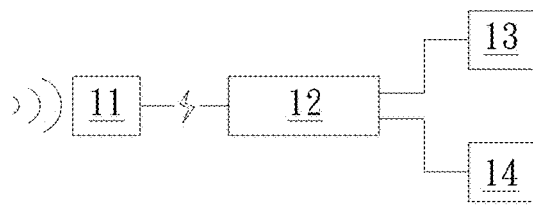

FIG. 1B

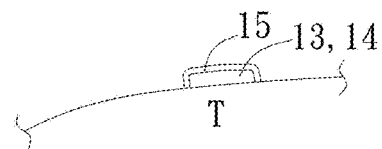

FIG. 1C

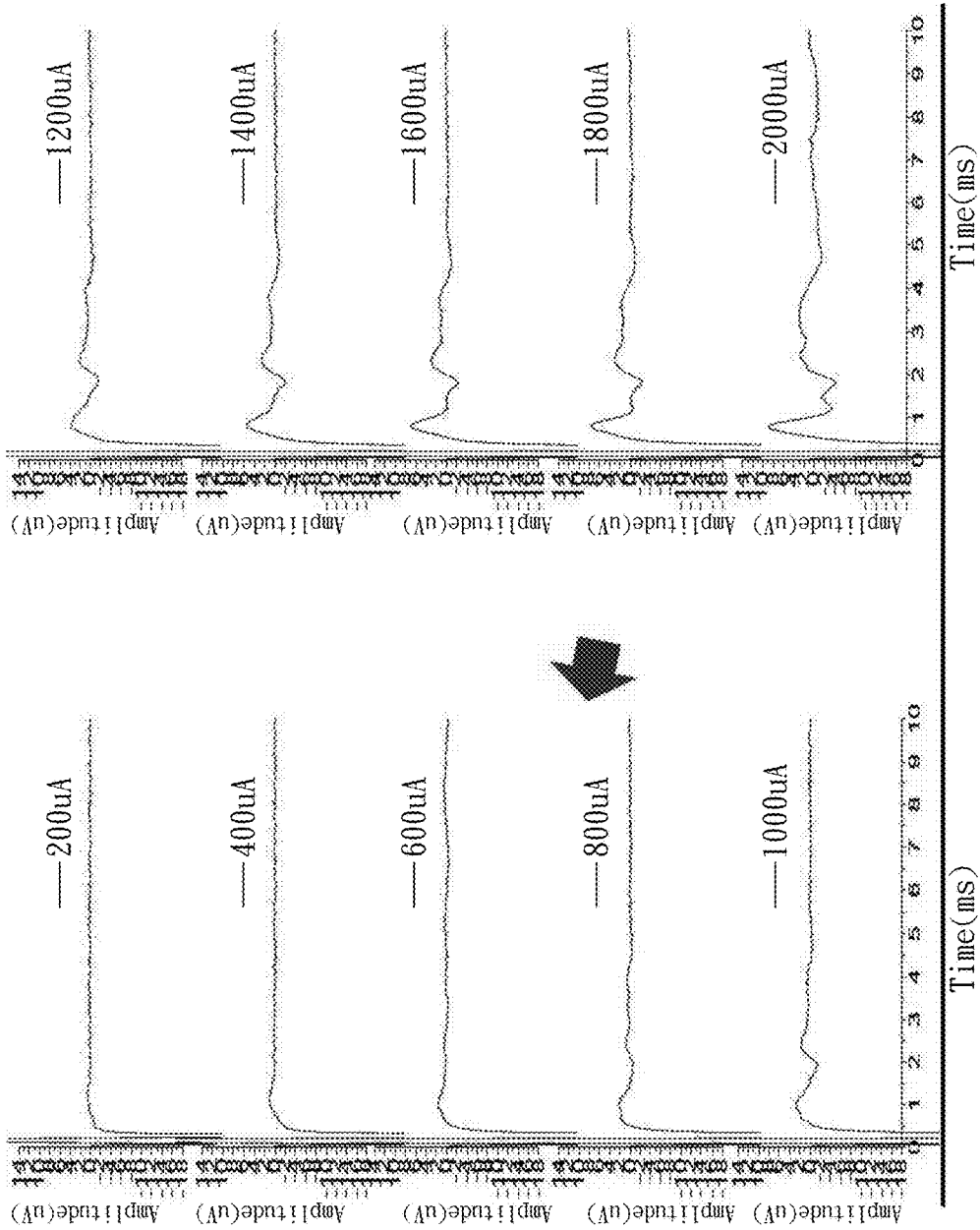

FIG. 1D

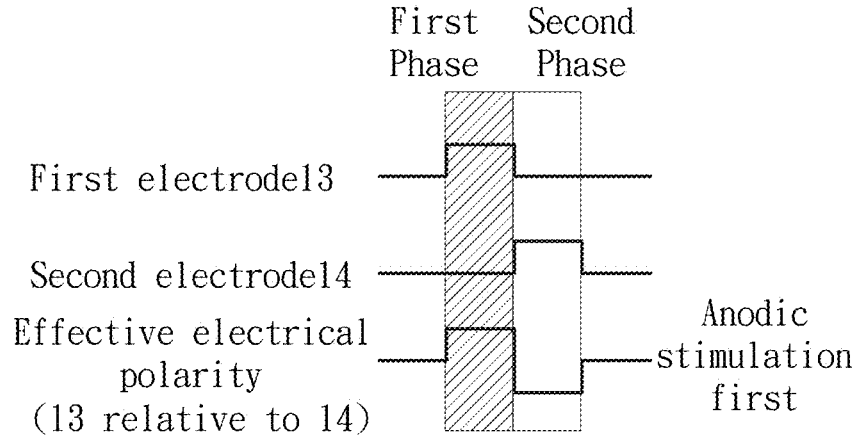

FIG. 2A

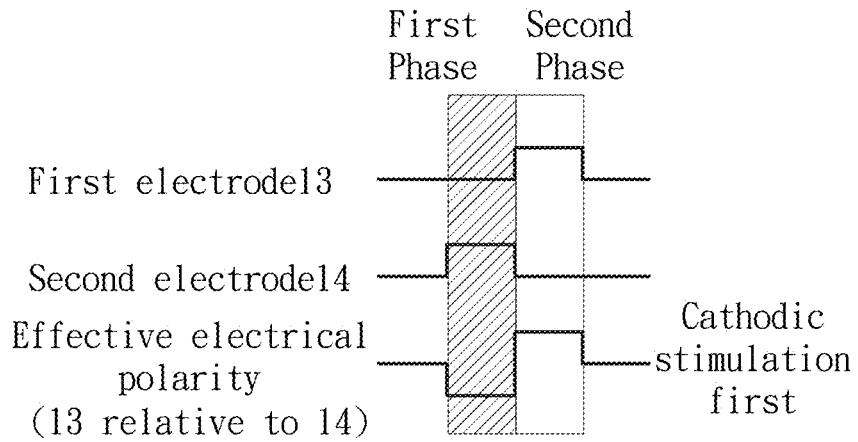

FIG. 2B

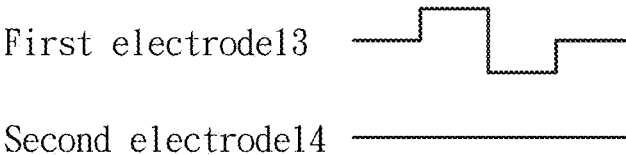

FIG. 3A

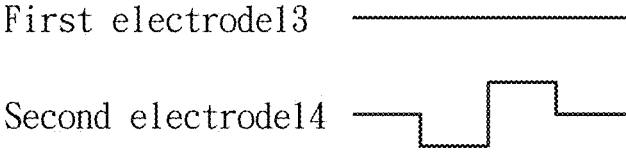

FIG. 3B

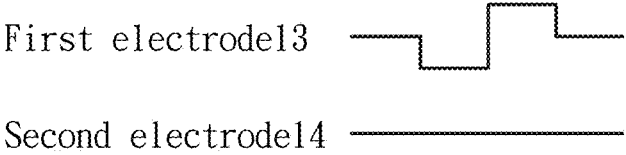

FIG. 3C

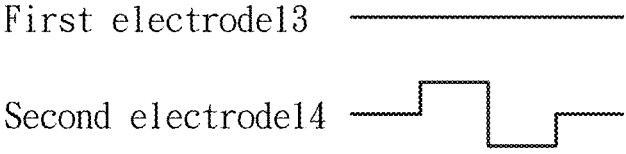

FIG. 3D

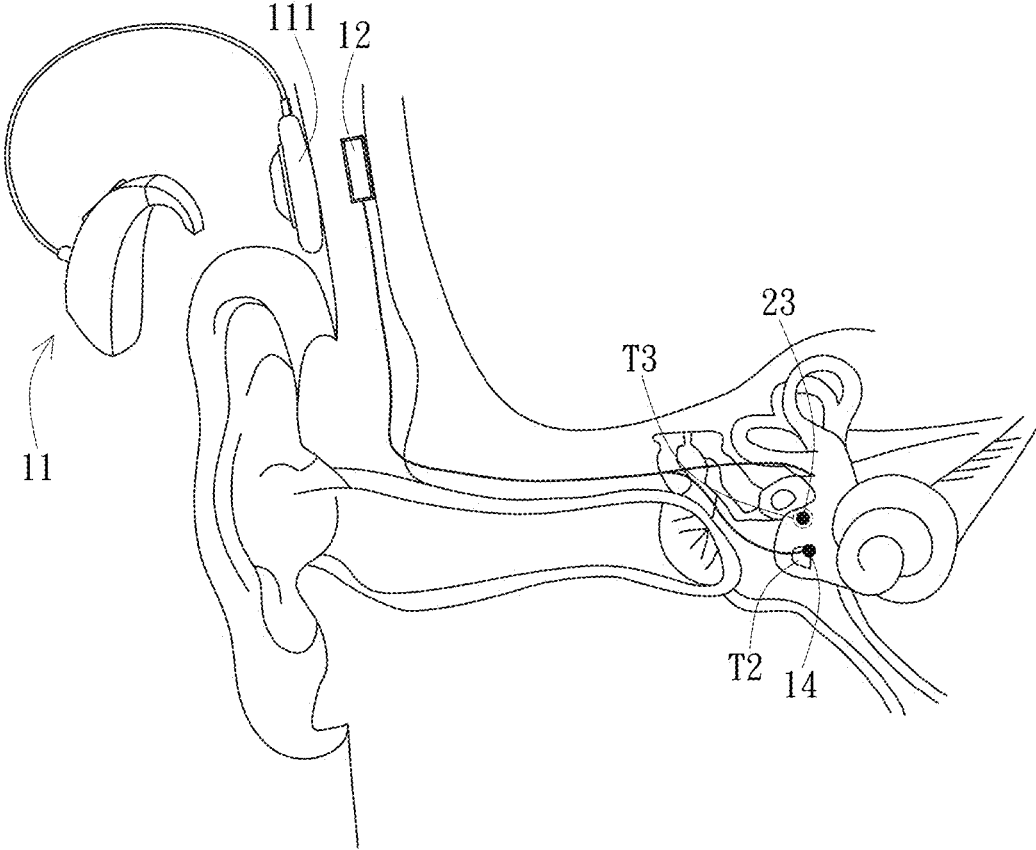

FIG. 4

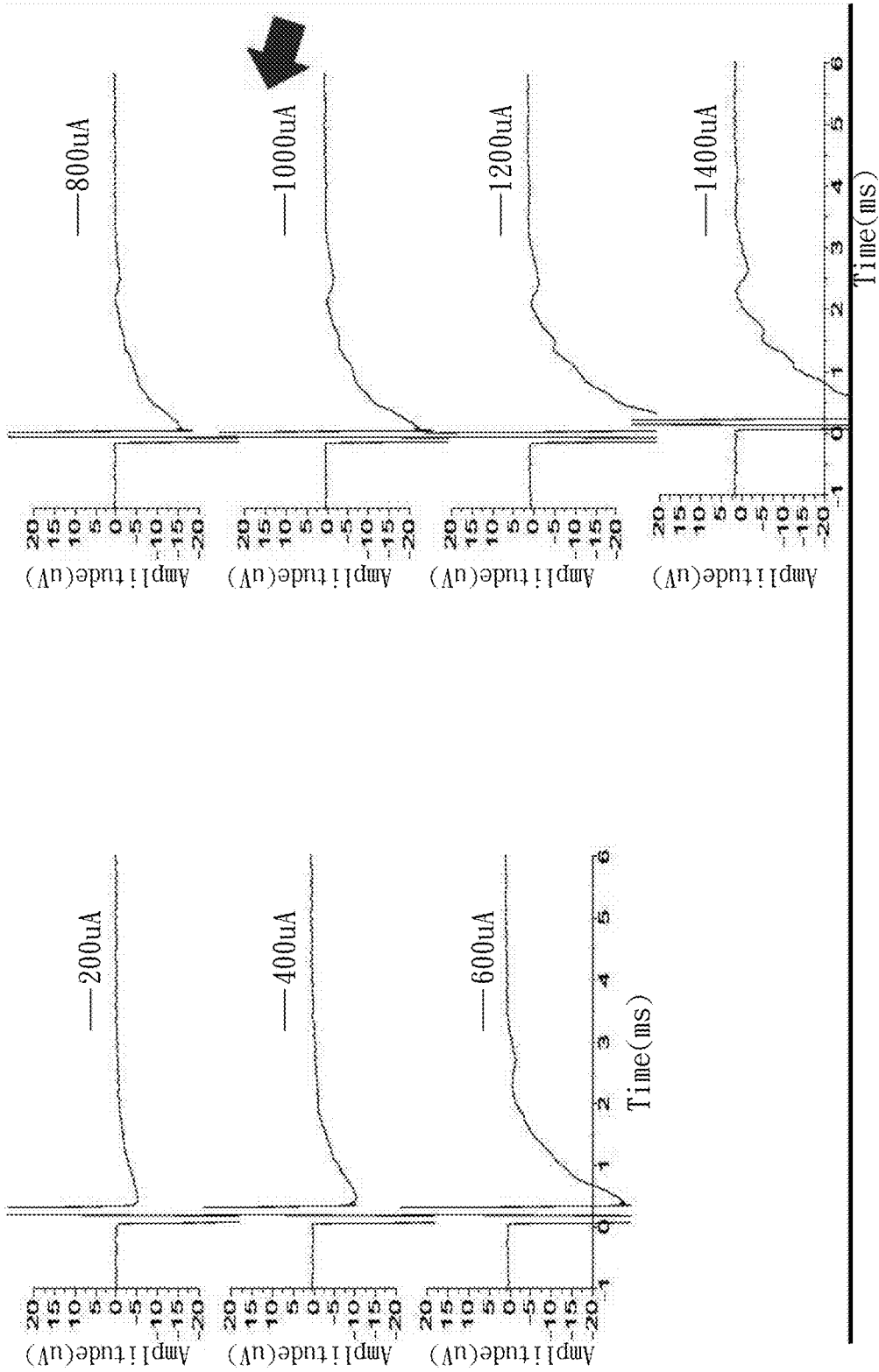

FIG. 5

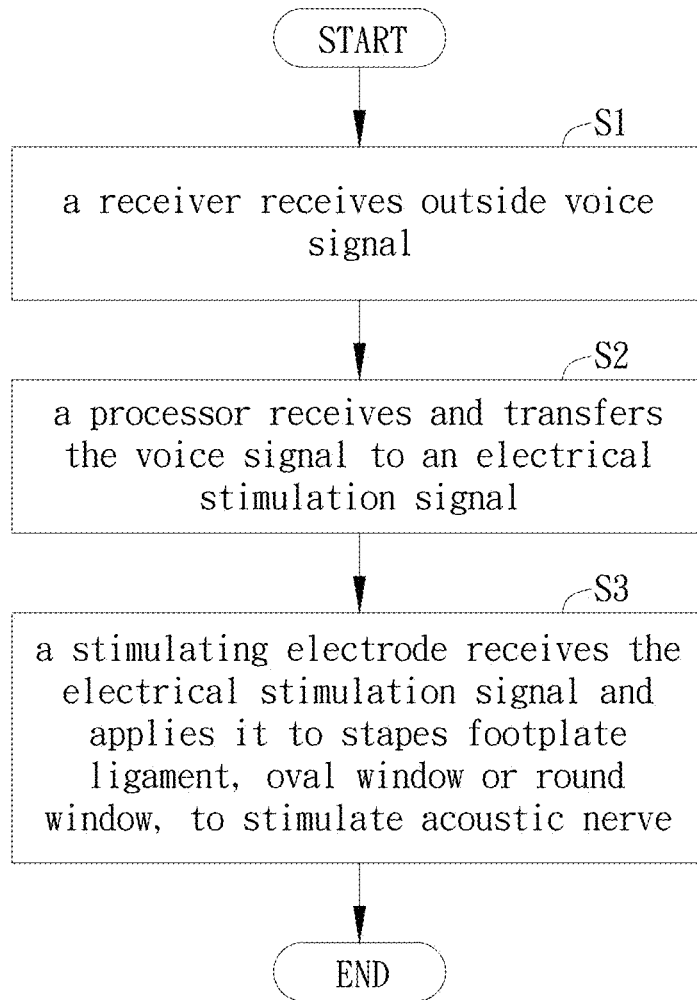

FIG. 6

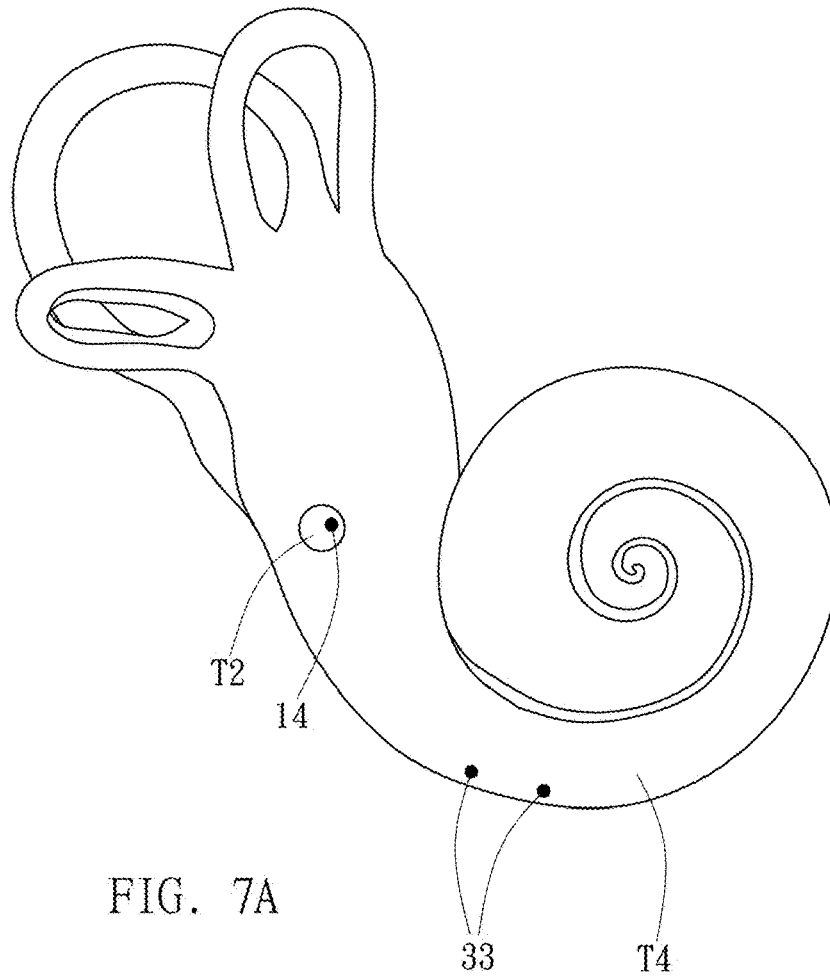
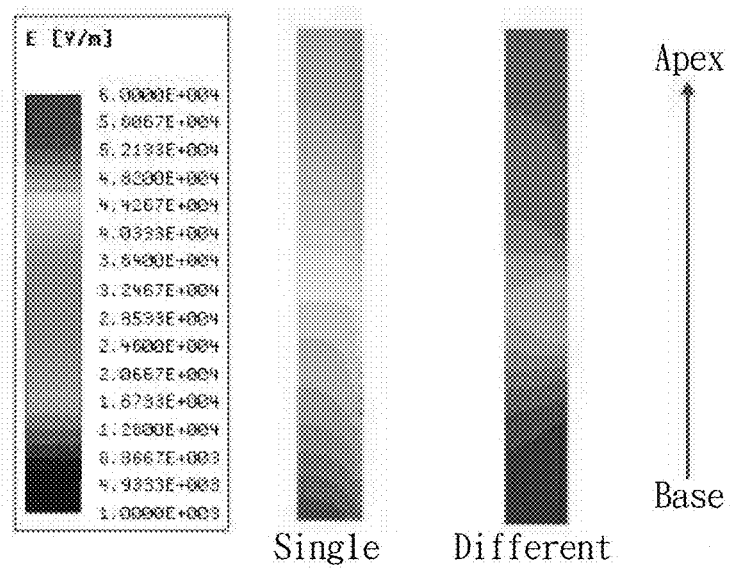

FIG. 7A



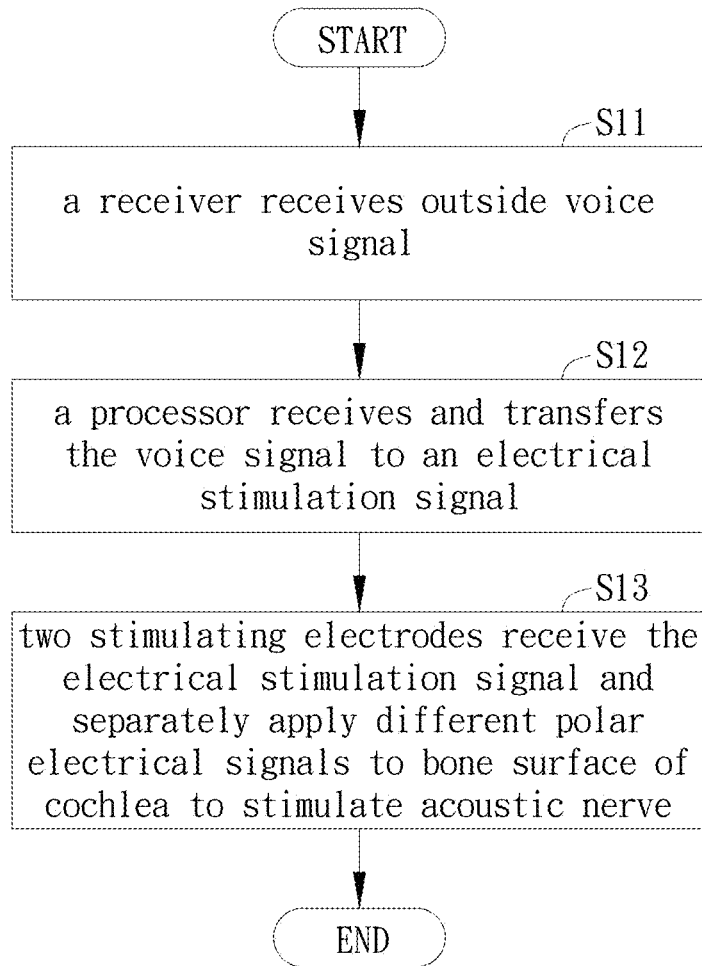

FIG. 8

COCHLEAR IMPLANT DEVICE AND STIMULATING METHOD THEREOF

BACKGROUND OF THE INVENTION

1. Field of the Invention

[0001] The present invention relates to a cochlear implant device and stimulating method thereof, especially a minimally invasive cochlear implant device and stimulating method thereof.

2. Description of the Prior Art

[0002] The hearing-impaired, whose hair cells are damaged or do not completely developed, but usually have partial nerve fibers which do not completely lose their function. A cochlear implant device could be utilized to replace those hair cells. The cochlear implant device directly stimulates the normal nerve fibers so that the hearing could be transmitted to brain through the normal nerve fibers.

[0003] Therefore, the hearing aids like cochlear implant devices are researched and developed. Traditional cochlear implant devices usually have surgical implant units, electrodes, connecting wires, transmitting coils, and an outside speech device. However, the electrodes must be implanted into the cochlea. The surgery is complicated and has high risk. In addition, the cost is also very expensive.

SUMMARY OF THE INVENTION

[0004] One aspect of the present invention provides a cochlear implant device. The electrode of the cochlear implant device is disposed on the outside of the cochlea so that the risk of the surgery can be reduced. In addition, the structure is simple so that the cost will also be reduced.

[0005] The cochlear implant device comprises a receiver, a processing device, a first electrode and a second electrode. The receiver is configured to receive outside voice signal. The processing device is coupled to the receiver, configured to receive and transfer the voice signal to an electrical stimulation signal. The first electrode connects to the processing device, disposed on stapes footplate ligament or oval window. The second electrode connects to the processing device, disposed on round window. Wherein the electrical stimulation signal is applied to stapes footplate ligament, oval window or round window to stimulate acoustic nerve through the first electrode or the second electrode.

[0006] Another aspect of the present invention provides a stimulating method. The electrode of the cochlear implant device is disposed on the outside of the cochlea so that the risk of the surgery can be reduced. In addition, the structure is simple so that the cost will also be reduced.

[0007] The stimulating method comprises the following steps: (S1) a receiver receives outside voice signal; (S2) a processor receives and transfers the voice signal to an electrical stimulation signal; and (S3) a stimulating electrode receives the electrical stimulation signal and applies it to stapes footplate ligament, oval window or round window, to stimulate acoustic nerve.

[0008] Another aspect of the present invention provides a cochlear implant device. The electrode of the cochlear implant device is disposed on the outside of the cochlea so that the risk of the surgery can be reduced. In addition, the structure is simple so that the cost will also be reduced.

[0009] The cochlear implant device comprises a receiver, a processing device, two first electrodes and a second electrode. The receiver is configured to receive outside voice signal. The processor is coupled to the receiver, configured to receive and transfer the voice signal to an electrical stimulation signal. The two first electrodes connect to the processor, disposed on bone surface of the cochlea, configured to receive the electrical stimulation signal and separately apply different polar electrical signals to the cochlear bone. The second electrode connects to the processor, disposed on round window, configured to be a counter electrode.

[0010] Another aspect of the present invention provides a stimulating method. The electrode of the cochlear implant device is disposed on the outside of the cochlea so that the risk of the surgery can be reduced. In addition, the structure is simple so that the cost will also be reduced.

[0011] The stimulating method comprises the following steps: (S11) a receiver receives outside voice signal; (S12) a processor receives and transfers the voice signal to an electrical stimulation signal; and (S13) two stimulating electrodes receive the electrical stimulation signal and separately apply different polar electrical signals to the bone surface of the cochlea to stimulate acoustic nerve.

[0012] Compared to the prior art, the present invention provides a simple electrode structure and a minimally invasive manner for the cochlea. Besides it can effectively stimulate acoustic nerve, it can reduce the risk of the surgery and the cost.

BRIEF DESCRIPTION OF THE DRAWINGS

[0013] The application file contains at least one drawing executed in color. Copies of this patent or patent application publication with color drawing will be provided by the Office upon request and payment of the necessary fee.

[0014] FIG. 1A is a schematic diagram of a cochlear implant device in the present invention.

[0015] FIG. 1B is a block diagram of the embodiment of FIG. 1A.

[0016] FIG. 1C is a side view diagram of one electrode in the present invention.

[0017] FIG. 1D is the electrical auditory brainstem response (EABR) measured waveform for the embodiment of FIG. 1A.

[0018] FIG. 2A and FIG. 2B are the electrical polarity (cathodic, anodic, or reference ground) on each electrode of a cochlear implant device in the present invention.

[0019] FIG. 3A~FIG. 3D are the another electrical polarity (cathodic, anodic, or reference ground) on each electrode of cochlear implant device in the present invention.

[0020] FIG. 4 is a schematic diagram of another stimulating method for cochlear implant device in the present invention.

[0021] FIG. 5 is the electrical auditory brainstem response (EABR) measured waveform of another stimulating method for cochlear implant device in the present invention.

[0022] FIG. 6 is a flowchart of a stimulating method in the present invention.

[0023] FIG. 7A and FIG. 7B are schematic diagrams of another stimulating method for cochlear implant device in the present invention.

[0024] FIG. 8 is a flowchart of another stimulating method in the present invention.

DETAILED DESCRIPTION OF THE
PREFERRED EMBODIMENT

[0025] Please refer to FIG. 1A, FIG. 1B and FIG. 1C. A cochlear implant device preferably comprises a receiver **11**, a processor **12**, a first electrode **13** and a second electrode **14**. The receiver **11** may be microphone or other speech processing devices. The receiver **11** is configured to receive outside voice signal, and then transfer the outside voice signal into wireless signal which is suitable for transmitting. The receiver **11** is like a normal hearing aid which could be hung on the ear, but not limited thereto.

[0026] The receiver **11** preferably comprises a processing unit (not shown) to transfer/encode voice signal into digital signal. In addition, the receiver **11** preferably connects to a sending coil **111** for transmitting the encoded voice signal through radio wave, but not limited thereto. In this embodiment, when the voice signal is transmitted by the receiver **11**, it is already transferred into a wireless signal. The sending coil **111** may be attached to the skin of the head near the auricle, but not limited thereto.

[0027] The processor **12** is preferably disposed on the mastoid bone, but not limited thereto. It preferably comprises a receiving coil, a processing unit, and a stimulator. The processor **12** receives the voice signal (wireless signal) from the receiver **11** through the receiving coil; then the processing unit receives the voice signal (wireless signal) and transfers/decodes it into an electrical stimulation signal.

[0028] The electrical stimulation signal can be transmitted to the first electrode **13** or the second electrode **14** by the stimulator.

[0029] In this embodiment, the first electrode **13** connects to the processor **12** and is disposed on the stapes footplate ligament **T1**. In detail, the first electrode **13** may be formed as a needle or a cylinder, and inserted into the stapes footplate ligament **T1** for a better stability. The inserted depth is better to not penetrate through the ligament tissue. That is, the first electrode **13** does not penetrate to the next tissue to avoid damaging other tissues.

[0030] It is noted that the first electrode **13** may be formed as a planar electrode. Compared to the inserted type, the planar electrode can reduce the degree of invasion. In this circumstance, the first electrode **13** may be attached to the stapes footplate ligament **T1** by biological glue (not shown) for a better stability. In addition, to avoid the rejection phenomenon between the first electrode **13** and other tissues inside the ear, a biocompatible layer **15** (e.g. polyimide or the like) may be used to cover the portion of the first electrode **13** does not contact with tissue **T**.

[0031] The second electrode **14** also connects to the processor **12** and is disposed on the round window **T2**. Similarly, the second electrode **14** is attached to **T2** by biological glue. A biocompatible layer **15** may be used to cover the portion of the second electrode **14** does not contact with tissue **T**.

[0032] In this embodiment, the first electrode **13** is configured to be a stimulating (working) electrode, and the second electrode **14** is configured to a counter electrode.

[0033] The first electrode **13** receives the electrical stimulation signal from the processor **12**, and then applies it to the stapes footplate ligament **T1**. Accordingly, the electrical stimulation signal (e.g. current or voltage) is preferably transmitted between electrodes **13** and **14** in biphasic stimulating manner. While stimulating the acoustic nerve, it can eliminate the accumulated charge in single-phase (mono-

phasic). It is noted that the minimum distance between the two electrodes cannot cause them conduct with each other. The electrical stimulation signal may be current or voltage. The current may supply a better stimulation. The stimulating manner is preferable biphasic, but not limited thereto.

[0034] In the animal experiment, as shown in FIG. 1D, is an electrical evoked auditory brainstem response (EABR). A neural action potential (pointed by the arrow) can be evoked when the current of the electrical stimulation signal reaches 800 μ A. In detail, the determination is based on the fifth wave occurs. In this embodiment, the fifth wave occurs while the current reaches 800 μ A.

[0035] However, in other embodiment, the first electrode **13** and the second electrode **14** may be interchanged. For example, when the first electrode **13** is a working electrode, the second electrode **14** is a counter electrode. Conversely, when the second electrode **14** is a working electrode, the first electrode **13** is a counter electrode. It is noted that, in the common biphasic stimulating manner, it can be divided into two categories. The first category, during a complete stimulation, each of the two electrodes stimulates half time respectively. As shown in FIG. 2A and FIG. 2B, when the first electrode **13** as a working electrode in first half stimulation, the second electrode **14** is configured to be a counter electrode. When the second electrode **14** as a working electrode in second half stimulation, the first electrode **13** is configured to be a counter electrode. The difference is that in an equivalent stimulation in FIG. 2A, the stimulation is first to positive and second to negative. Due to the stimulation is negative polarity in the end, the corresponding voltage is a negative voltage. Accordingly, the biological reaction is a positive voltage is easy to be observed. In FIG. 2B, the equivalent stimulation is first to negative and second to positive. It has a much safer stimulation.

[0036] The second category, during a complete stimulation, the first electrode **13** and the second electrode **14** do not interchange. As shown in FIG. 3A~FIG. 3D, when the first electrode **13** as a working electrode, it supplies positive stimulation and negative stimulation, and the second electrode **14** is only configured to be a counter electrode. Conversely, when the second electrode **14** as a working electrode, it supplies positive stimulation and negative stimulation, and the first electrode **13** is only configured to be a counter electrode.

[0037] In the first category, each of the two electrodes stimulates half time respectively so that the cost of the negative voltage or current of the stimulator may be saved. In the second category, anyone of the two electrodes may be designated to be a reference bias.

[0038] It is noted that, the first electrode **13** and the second electrode **14** may be formed as a circle, a rectangle, a cylinder, a pyramid, or a needle. There is no specific restriction.

[0039] In another embodiment, please refer to FIG. 4. The main structure is similar to the above embodiment. In this embodiment, the first electrode **23** is disposed on the oval window **T3**, and the second electrode **24** is still disposed on the round window **T2**. The first electrode **23** receives the electrical stimulation signal from the processor, and then applies it to the oval window **T3** to stimulate the acoustic nerve. It is noted that both two ways can cure the tinnitus, however, the location of stapes footplate ligament **T1**-round window **T2** is much more easily effectively stimulated by inserting an inserted electrode into **T1**. The location of oval

window T3-round window T2 is suitable for using a planar electrode for a minimally invasive way. The needle electrode is used to dispose on the stapes footplate ligament T1 and the planar electrode is used to dispose on the oval window T3, but not limited thereto.

[0040] In another embodiment, the first electrode is disposed on the stapes, and the second is still disposed on the round window. In this embodiment, due to the first electrode is directly disposed on the bone, the first electrode is attached to the stapes through a bio-screw, but not limited thereto. The attached manner for the second electrode is similar to the above embodiment. As shown in FIG. 5, the data of the animal experiment shows that a neural action potential (pointed by the arrow) can be evoked when the current of the electrical stimulation signal reaches 1000 μ A.

[0041] In a preferable embodiment, the current of the electrical stimulation signal is set about 300~1000 μ A to effectively evoke the neural action potential. However, it is noted that the current value actually relates to the stimulating time. For example, in order to generate a current which could sufficiently evoke the neural action potential, when the stimulating time is shorter, the needed current is larger. Conversely, when the stimulating time is longer, the needed current is smaller. Therefore, the current 300~1000 μ A in this embodiment is only an example, not limited thereto. The upper limit of the electrical stimulation signal is preferable not to cause the adjacent tissue reactions.

[0042] Another embodiment in the present invention, as shown in FIG. 6. It is a stimulating method applied to the embodiment of FIG. 1A. The method comprises follow steps: (S1) a receiver receives outside voice signal; (S2) a processor receives and transfers the voice signal to an electrical stimulation signal; and (S3) a stimulating electrode receives the electrical stimulation signal and applies it to stapes footplate ligament, oval window or round window, to stimulate acoustic nerve.

[0043] The hardware structure for the stimulating method is described on the above embodiment, it is not discussed here.

[0044] Another embodiment in the present invention, as shown in FIG. 7A and FIG. 7B. A cochlear implant device preferably comprises a receiver, a processor, two first electrodes 33 and a second electrode 14. Except for the location of the electrodes, other elements (not shown) are similar to the above embodiment.

[0045] The receiver is like a normal hearing aid which could be hung on the ear, but not limited thereto. The receiver preferably comprises a processing unit (not shown) to transfer/encode voice signal into digital signal. In addition, the receiver preferably connects to a sending coil for transmitting the encoded voice signal through radio wave, but not limited thereto. In this embodiment, when the voice signal is transmitted by the receiver, it is already transferred into a wireless signal. The sending coil may be attached to the skin of the head near the auricle, but not limited thereto.

[0046] The processor is preferably disposed on the mastoid bone, but not limited thereto. It preferably comprises a receiving coil, a processing unit, and a stimulator. The processor receives the voice signal (wireless signal) from the receiver through the receiving coil; then the processing unit receives the voice signal (wireless signal) and transfers/decodes it into an electrical stimulation signal. The electrical stimulation signal can be transmitted to the electrode by the stimulator.

[0047] In this embodiment, the two first electrodes 33 are configured to be stimulating electrodes. They both connect to the processor and disposed on the bone surface of the cochlea T4. The preferable position locates on the high-frequency area.

[0048] Consider the basement of the cochlea is a high-frequency area, the electrodes 33 position may be the area where the acoustic frequency exceeds 1000 Hz. This way has an ability to compensate high frequency of hearing impair. Specifically, electrodes 33 can be disposed on the area where the frequency is 5000 Hz~15000 Hz. The 1000 Hz is used to be a boundary between reserving original low-frequency hearing (<1000 Hz) and the electrical stimulation. The second electrode also connects to the processor and is disposed on the round window T2, is configured to be a counter electrode.

[0049] The first electrodes 33 are disposed on the bone surface of the cochlea, preferably located on the high-frequency area for supplying high-frequency response electrical stimulation signal to avoid damaging the cochlea. The first electrodes 33 receive the electrical stimulation signal and separately apply different polar electrical signals to the cochlear bone. It is noted that, to separately apply different polar electrical signals, there are at least two first electrodes needed and a second electrode. However, in other embodiment, take four first electrodes and a second electrode as an example for a simulated test. As shown in FIG. 7B, if only one electrode is given the voltage signal (e.g. only one of the first electrodes supplies the electrical stimulation signal), the electrical field distribution can be obtained as shown (single). If different polar voltage signals are applied (e.g. four first electrodes respectively apply -2V, -2V, +10V and -1V) to the cochlear bone, the electrical field distribution can be obtained as shown (different). FIG. 7B shows the electrical field distribution of base (high-frequency area) through apex (low-frequency area) of the cochlea. The voltage values are only taken for an example, but not limited thereto.

[0050] By separately applying different polar electrical signals, it can accurately control the stimulating position. In practice by this way, the purpose is to limit the stimulating target on the specific area and eliminate the wrong stimulation on other areas.

[0051] It is noted that, the above embodiment arranges two and four first electrodes, however, when the process development is much more mature, the size of the electrode will be reduced. Therefore, in the same area the arranged electrode will increase. The minimum distance between each two electrodes cannot cause they conduct with each other.

[0052] In this embodiment, the portions where the first electrodes 33 and the second electrode 14 do not contact with T2 and T4 respectively, covered by biocompatible layers. Wherein the first electrodes 33 may be attached to the bone surface of the cochlea by bio-screws.

[0053] Another embodiment in the present invention, as shown in FIG. 8. It is a stimulating method applied to the embodiment of FIG. 7. The method comprises follow steps: (S11) a receiver receives outside voice signal; (S12) a processor receives and transfers the voice signal to an electrical stimulation signal; and (S13) two stimulating electrodes receive the electrical stimulation signal and separately apply different polar electrical signals to the bone surface of the cochlea to stimulate acoustic nerve.

[0054] The hardware structure for the stimulating method is described on the above embodiment, it is not discussed here.

[0055] Compared to the prior art, the present invention provides a simple electrode structure and a minimally invasive manner for the cochlea. Besides it can effectively stimulate acoustic nerve, it can reduce the risk of the surgery and the cost.

[0056] Although the preferred embodiments of the present invention have been described herein, the above description is merely illustrative. Further modification of the invention herein disclosed will occur to those skilled in the respective arts and all such modifications are deemed to be within the scope of the invention as defined by the appended claims.

What is claimed is:

1. A cochlear implant device, comprising:
 - a receiver, configured to receive outside voice signal;
 - a processor is coupled to the receiver, configured to receive and transfer the voice signal to an electrical stimulation signal;
 - a first electrode connects to the processor, disposed on stapes footplate ligament or oval window; and
 - a second electrode connects to the processor, disposed on round window;
 wherein the electrical stimulation signal is applied to stapes footplate ligament, oval window or round window to stimulate acoustic nerve through the first electrode or the second electrode.
2. The device as claimed in claim 1, wherein the first electrode is attached to the stapes footplate ligament or the oval window through gel, and the second electrode is attached to the round window through gel.
3. The device as claimed in claim 1, wherein the first electrode and the second electrode are partially covered by a biocompatible layer, respectively.
4. The device as claimed in claim 1, wherein the electrical stimulation signal is transferred between the stapes footplate ligament and the round window, or between the oval window and the round window.
5. The device as claimed in claim 1, the other one of the first electrode and the second electrode is configured to be a counter electrode.
6. The device as claimed in claim 1, wherein the electrical stimulation signal is about 300~1000 μ A.
7. A stimulating method for a cochlear implant device, comprising:
 - (S1) a receiver receives outside voice signal;
 - (S2) a processor receives and transfers the voice signal to an electrical stimulation signal; and

(S3) a stimulating electrode receives the electrical stimulation signal and applies it to stapes footplate ligament, oval window or round window, to stimulate acoustic nerve.

8. The method as claimed in claim 7, wherein the stimulating electrode is attached to the stapes footplate ligament, the oval window or the round window through gel.

9. The method as claimed in claim 7, wherein the stimulating electrode is partially covered by a biocompatible layer.

10. The method as claimed in claim 7, wherein the electrical stimulation signal is transferred between the stapes footplate ligament and the round window, or between the oval window and the round window.

11. A cochlear implant device, comprising:

- a receiver, configured to receive outside voice signal;
- a processor is coupled to the receiver, configured to receive and transfer the voice signal to an electrical stimulation signal;
- at least two first electrodes connect to the processor, disposed on bone surface of cochlea, configured to receive the electrical stimulation signal and separately apply different polar electrical signals to the bone surface of the cochlea; and
- a second electrode connects to the processor, disposed on round window, configured to be a counter electrode.

12. The device as claimed in claim 11, wherein the first electrodes and the second electrode are partially covered by a biocompatible layer, respectively.

13. The device as claimed in claim 11, wherein the first electrodes and the second electrode are disposed on the bone surface of the cochlea by bio-screws respectively.

14. The device as claimed in claim 11, wherein the electrical stimulation signal is about 300~1000 μ A.

15. A stimulating method for a cochlear implant device, comprising:

- (S11) a receiver receives outside voice signal;
- (S12) a processor receives and transfers the voice signal to an electrical stimulation signal; and
- (S13) two stimulating electrodes receive the electrical stimulation signal and separately apply different polar electrical signals to bone surface of cochlea to stimulate acoustic nerve.

16. The method as claimed in claim 15, wherein the stimulating electrodes are disposed on the bone surface of the cochlea by bio-screws respectively.

17. The method as claimed in claim 15, wherein the stimulating electrodes are partially covered by a biocompatible layer respectively.

* * * * *