

# An effect scheme for fixed-length tunnel allocation in hierarchical WDM networks

Tse-Yu Lo, Chien Chen, and Ying-Yu Chen

Department of Computer and Information Science, National Chiao Tung University  
1001 Ta Hsueh Road, Hsinchu, Taiwan 300, ROC

## ABSTRACT

In this paper, we investigate the static tunnel allocation problem in multigranularity optical cross-connect (MG-OXC) networks. Our goal is to allocate a set of tunnels that minimize the blocking probability for the dynamic traffic that will follow the prior-known historical traffic matrix. A heuristic Capacity-Balanced Static Tunnel Allocation (CB-STA) has been proposed [1], which always tries to allocate a tunnel from the node with maximal predicted traffic going out to the node with maximal predicted traffic coming in. However, the tunnel length constraint is not carefully considered while selecting node pairs. Thus, this work proposes a heuristic, Weighted Tunnel Allocation (WTA), to improve CB-STA. WTA adds some additional edges with predefined hop length, termed auxiliary links, to the original topology to form an auxiliary graph. Node pair incident to an auxiliary link means that there could be tunnels allocated for it. By routing the historical traffic on the auxiliary graph, preference of tunnel allocation for each node pair incident to the auxiliary link can be estimated. Finally the tunnels will be allocated according to the preference. The simulation results show that WTA outperforms CB-STA in all switching type combinations.

**Keywords:** Multigranularity optical cross-connect (MG-OXC), tunnel allocation, Capacity-Balanced Static Tunnel Allocation (CB-STA), tunnel length constraint, Weighted Tunnel Allocation (WTA), auxiliary graph

## 1. INTRODUCTION

Wavelength-division-multiplexing (WDM) networks have emerged as a method of providing Terabits-per-second capacity for ever-increasing bandwidth demands. While increase in number of wavelength channels and fibers between node pairs may increase available capacity, the resultant managing complexity and switching fabric of optical cross-connects (OXCs) also increase. An effective way of handling this problem is to bundle a group of consecutive wavelength channels together and switch them as a single unit on the specific route to reduce the required resources of intermediate cross-connects along the route. The tunnel-like passage created by the bundled wavelength channels is defined as a waveband/fiber tunnel. Wavelengths in a tunnel must be switched together except at the two ends of the tunnel. Nodes that support such multigranularity switching, e.g. wavelength, waveband and fiber-switching, is termed hierarchical cross-connects or multigranularity optical cross-connects (MG-OXCs).

Generally, the research topics about MG-OXCs can be categorized into (a) given the network resources, minimize the blocking probability of the coming requests, and (b) dimension the network resources when given the set of traffic requests. In [2], merits of hierarchical OXC, or MG-OXC, were summarized such as small-scale modularity, reduced cross-talk, and the reduced of complexity. [3] showed that the number of ports required when grouping of consecutive lightpaths are applied to the network (excluding grouping the traffic from different source nodes to different destination nodes) can be significantly reduced. In [1] a novel switching architecture, MG-OXC was proposed to minimize the blocking probability for the dynamic requests given the limited network resources. In [4], which employs a two-stage scheme of waveband and wavelength, an integer linear programming (ILP) formulation and a heuristic are given that aim to group lightpaths with the same destination only, while in [5] both the ILP and heuristic were given to handle the more general cases. Continuing with [5], [6] further studies Single-Layer MG-OXCs and Multi-Layer MG-OXCs under both off-line and on-line traffic.

In this paper, we consider the following network design problem. Given fixed amount of network resources and a historical traffic matrix that the dynamic requests will follow, the objective is to determine a set of tunnels that minimize the blocking probability for the dynamic traffic requests. The heuristic Capacity-Balanced Static Tunnel Allocation

(CB-STA) [1] has been proposed that first estimates the amount of traffic traveling through each node by routing the historical traffic matrix in the network. Then the nodes with maximal traffic going out and maximal traffic coming in are selected repeatedly for tunnel allocation. To efficiently utilize the wavelength ports and fibers, each node pair selected for tunnel allocation is required to follow a tunnel length constraint, i.e., each tunnel should be equal to an average hop distance. However, CB-STA does not consider the tunnel length constraint when picking the node pairs, resulting in only few of the selected pairs for tunnel allocation comply with the length constraint.

We propose a heuristic, Weighted Tunnel Allocation (WTA), to better utilize the network resources than CB-STA. Instead of finding node pairs for the tunnel allocation without considering the tunnel length constraint, WTA only take node pairs that comply with the length constraint into consideration. A novel auxiliary graph model is constructed to facilitate tunnel allocation for these node pairs. The auxiliary graph is constructed by adding edges to the original topology on the node pairs whose shortest hop distance comply with the predefined length constraint. By routing the historical traffic on the auxiliary graph, preference of tunnel allocation for each node pair incident to the auxiliary link can be estimated. Finally the tunnels will be allocated according to the preference.

The remainder of this paper is organized as follows. In Section 2, we briefly describe the node architecture used in our study, which was proposed in [1]. Section 3 gives the basic concepts on the tunnel allocation problem and the assumptions our study is based on. In Section 4, we briefly describe the CB-STA in [1] and then present our heuristic WTA. Simulation results are given in Section 5. The paper concludes in Section 6.

## 2. MULTIGRANULARITY OPTICAL CROSS CONNECTS (MG-OXC)

The node architecture [1], shown in Fig. 1, used in our study is described as follows. A MG-OXC mainly comprises fiber-, waveband-, and wavelength-switching boxes and waveband and wavelength multiplexer/de-multiplexers. The fiber- and waveband-switching boxes on the left-hand side serve as selectors on the input fibers and wavebands while the fiber- and waveband-switching boxes on the right-hand side serve as OXCs that switch fibers and wavebands. In a network comprising of MG-OXCs, a tunnel is a group of consecutive wavelength channels that are bundled and switched together as a single unit, which is either a fiber or waveband tunnel. All of the channels in a waveband or fiber tunnel must be switched together. A wavelength-switching port is required when a lightpath enters or exits a tunnel so that the traffic can be grouped or de-grouped. In Fig. 2, there is a tunnel between node A and node C. A lightpath from node A to node C can be established by traversing that tunnel. Note that the number of wavelength-switching ports the tunnel consumes at the two ends of the tunnel is equal to the number of the wavelengths that the tunnel carries.

The advantage of using MG-OXC is cost reduction in the switch fabric. Fig. 3 gives an example. Assume that there are ten wavelengths in a fiber and a node has two fibers coming in and going out. In Fig. 3 (a), the traditional OXC uses a  $20 \times 20$  wavelength switch. However, in Fig. 3 (b), the MG-OXC uses a  $10 \times 10$  wavelength switch and two  $4 \times 4$  fiber switches. Although cost savings can be achieved by using MG-OXCs, it reduces the throughput and the performance of the networks. For example, in Fig. 3 (b), the traffic in the fiber can be accessed by de-multiplexing only one of the two fibers into wavelengths. The traffic in the other fiber can only bypass this node since no wavelength-switching ports can be used to de-multiplex the wavelengths in this fiber. Therefore, it needs a carefully designed tunnel allocation algorithm to achieve better tradeoff between the cost savings and performance degradation.

## 3. BASIC ASSUMPTIONS AND TUNNEL ALLOCATION CHARACTERISTICS

This section describes the basic assumptions our study is based on. A directional link in network with MG-OXCs consists of  $F$  fibers, in which  $F_1$ ,  $F_2$ , and  $F_3$  fibers are assigned as fiber-switched, waveband-switched, and wavelength-switched fibers respectively (i.e.  $F = F_1 + F_2 + F_3$ ). Each node is assumed to be equipped with sufficient wavelength conversion capability in the wavelength-switching layer. Therefore, a lightpath in the wavelength-switching layer can be converted into any other wavelength if necessary. The tunnels are restricted to traverse only on their shortest paths from their ingress to egress node thus increasing the efficiency of the network resource consumption.

A tunnel can be allocated between a node pair, if there is free capacity on each link along its route. Note that for

the waveband tunnel, it has to use the same waveband on each link along the route. To bring up an allocated tunnel, wavelength-switching ports are further required at the two ends of the tunnel. We assume that a historical traffic matrix is known a priori and the incoming dynamic requests follow the historical traffic matrix. This information is certainly useful for us to allocate tunnels off-line before the serving lightpath requests to decrease the blocking probability and improve network throughput.

Fig. 4 illustrates ways of tunnel allocation when the tunnel length is restricted to two. Fig. 4 (a) is part of the physical network. Four fibers,  $A \rightarrow B$ ,  $B \rightarrow D$ ,  $D \rightarrow C$  and  $C \rightarrow A$ , are used for tunnel allocation. Fig. 4 (b) and (c) show the two possible ways of tunnel allocation. The total traffic trend should be considered when deciding which tunnel set is suitable. For example, if most traffic is between node  $A$  and node  $D$ , the tunnel set in Fig. 4 (b) is more suitable. If most traffic is between node  $B$  and node  $C$ , the tunnels are allocated as in Fig. 4 (c).

#### 4. Weighted Tunnel Allocation (WTA)

We first introduce previous work on tunnel allocation proposed in [1], named Capacity-Balanced Static Tunnel Allocation (CB-STA). Then we propose our heuristic Weighted Tunnel Allocation (WTA) that aims to improve CB-STA. CB-STA allocates tunnels off-line before start serving the lightpath requests. The process comprises three stages: 1) tunnel ingress-egress (I-E) pair selection, 2) tunnel allocation and 3) makeup process. In 1), a series of I-E pairs are selected sequentially for the next stage. To select I-E pairs, CB-STA estimates the amount of traffic traveling through each node by routing the historical traffic matrix in the network. Then the nodes with maximal traffic going out and maximal traffic coming in are selected repeatedly for tunnel allocation. In 2), CB-STA tries to allocate a tunnel for each I-E pair selected in 1). Stage 3) is performed to further utilize the remaining resources to fill the fiber- and waveband-switching layer with as many tunnels as possible.

Note that tunnels allocated at stage 2) is required to follow a tunnel length constraint, which is set to the minimum integer that is larger than the average physical hop distance between each node pair in the network. This is because when the tunnel length is too small, although the short tunnels are flexible and easily utilized by most of the lightpaths, the wavelength-switching ports are used up easily since the wavelength-switching ports are required at the ingress and egress nodes of each tunnel. When the tunnel length is too large, although wavelength-switching ports can be greatly saved, the tunnels may not be suitable for the requests since most of the lightpath requests are shorter than the tunnels. We observe that the I-E pairs selected in stage 1) of CB-STA does not consider the tunnel length constraint, leading to the result that most of the tunnels are allocated at stage 3), leaving the performance of CB-STA some space to be improved.

Instead of finding node pairs for tunnel allocation without considering the tunnel length constraint, WTA only takes node pairs whose hop distance comply with the length constraint into consideration. Only those node pairs possess the potential to be allocated tunnels. WTA is based on an auxiliary graph used to rate the preference of tunnel allocation for each node pair. The process comprises four stages: a) construction of auxiliary graph, b) weight calculation for edges in the auxiliary graph, c) weighted auxiliary graph based tunnel allocation, and d) makeup process. Details are described as follows.

**a) construction of auxiliary graph** Let  $G(V, E_p)$  be the original topology where  $V$  denotes the set of nodes and  $E_p$  represents the set of all physical links connecting the nodes. The auxiliary graph  $G'(V, E')$  is constructed by adding auxiliary links  $E_l$  between the node pairs that have their shortest physical hop length follow the length constraint (i.e.,  $E' = E_p + E_l$ ). The auxiliary links represent the potential tunnels that could be allocated on the network. Fig. 5 gives an example of construction of auxiliary graph where Fig. 5(a) is the original topology with the average hop distance equal to two and Fig. 5(b) is the corresponding auxiliary graph.

**b) weight calculation for edges in the auxiliary graph** The weight of an auxiliary link is actually the predicted summation of loads on the tunnels between the nodes incident to that link. The historical traffic matrix is taken as the input traffic. We assume that the traffic for each node pair is evenly distributed on its shortest paths on the auxiliary graph. Fig. 6 gives an example of how the weights are derived. There are three shortest paths from node  $s$  to  $d$ . Traffic from  $s$  to  $d$  is assumed to be evenly distributed on the three paths. Therefore, node pair  $(s, d)$  contribute one third of its traffic on each link traversed by the three shortest paths. Weight of an auxiliary link is calculated by summing up

the traffic of each node pair flowing through that link. The larger the weight of an auxiliary link, the higher chance the node pair for that link will be allocated tunnels.

**c) weighted auxiliary graph based tunnel allocation** This stage applies a greedy approach to allocate a set of tunnels according to the weight derived in the previous stage. The auxiliary link in  $G'$  with the maximum weight is first selected, and an attempt is made to allocate a fiber tunnel for this auxiliary link. If a fiber tunnel can be successfully allocated, the weight of this auxiliary link is decreased by  $\delta_F = \Psi_{\text{total}} / (U_F + U_B/B)$ , where  $\Psi_{\text{total}}$  denotes the total weight of all auxiliary links,  $B$  the number of wavebands in a fiber,  $U_F$  and  $U_B$  the upper bound of the number of fiber and waveband tunnels respectively.  $U_F$  and  $U_B$  are calculated by  $|E_p| \cdot F_1 / D$  and  $|E_p| \cdot F_2 \cdot B / D$  respectively, where  $|E_p|$  is the number of directional links on the topology and  $D$  the tunnel length constraint. If it fails to allocate a fiber tunnel, we try to allocate a waveband tunnel for this auxiliary link. If a waveband tunnel can be successfully allocated, the weight of this auxiliary link is decreased by  $\delta_B = \Psi_{\text{total}} / (U_F \cdot B + U_B)$ . If both fiber and waveband tunnels fail to be allocated, the weight of this auxiliary link is set to 0. The above procedure is repeated until all of the weights of the auxiliary links in  $G'$  are equal to or less than 0.

**d) makeup process** This process is used to further utilize the remaining resource after stage (c). Tunnels allocated in this stage do not have to follow the length constraint.

The following summarizes the WTA.

---

#### Weighted Tunnel Allocation (WTA)

- Step1. Form the auxiliary graph by adding all possible tunnels to the physical network.
  - Step2. Compute weight for each possible tunnel by routing the traffic matrix on the auxiliary graph
  - Step3. Stop if the weight for each auxiliary link is smaller or equal to 0.
  - Step4. Try to allocate fiber tunnel for the auxiliary link with maximum weight. If successful, decrease the weight of this auxiliary link by  $\delta_F$  and go to Step 3. Otherwise, go to Step 5.
  - Step5. Try to allocate waveband tunnel for this auxiliary link. Decrease the weight of this auxiliary link by  $\delta_B$ . Go to Step 3.
- 

In WTA and CB-STA, a tunnel is allocated if free link capacity on the route between the ingress and egress of the tunnel is available. An allocated tunnel needs to be further brought up to be utilized by lightpaths. When a tunnel is brought up, wavelength-switching ports are needed so that wavelengths can be group or de-group at two ends of the tunnel. The number of wavelength-switching ports consumed at each end of the tunnel so that the tunnel can be brought up is equal to the capacity (in wavelength) of that tunnel. Therefore, a Port-Constraint Weighted Tunnel Allocation (PC-WTA) is proposed with modification on WTA. In PC-WTA, after a tunnel is allocated, wavelength-switching ports at the ingress and egress nodes of the tunnel are dedicated to the tunnel. That is, a tunnel can not be allocated if any on the two ends of the tunnel has insufficient wavelength-switching ports. PC-WTA improves the performance when the wavelength-switching capability is significantly fewer than the resources in the fiber-switching and waveband-switching layers. Performance of the schemes described above is evaluated in the following section.

## 5. SIMULATION RESULTS

The topology we use is a 16-node network show in Fig. 7. We assume that each directional link has five fibers. Each fiber contains forty wavelengths which are divided into four wavebands with wavelength 1 to 10 in the first waveband, 11 to 20 the second, ..., and 31 to 40 the forth. The traffic is uniformly distributed on all node pairs and each request is for a lightpath. The inter-arrival time between two requests is determined by the poisson distribution function with rate  $\rho$ , and the request holds the resources it traverses for a time period determined by an exponential distribution function with rate 1. We denote  $(F_1)F(F_2)B(F_3)L$  the experiment with  $F_1$  fibers for fiber-switching,  $F_2$  fibers for waveband-switching, and  $F_3$  fibers for wavelength-switching for each directional link.

Fig. 8 compares the number of allocated tunnels when CB-STA and WTA are used without performing their makeup process. The ideal number of allocated fiber tunnels and waveband tunnels are  $U_F$  and  $U_B$ , respectively. The

number of allocated fiber/waveband tunnels without makeup process in CB-STA is considerably smaller than the ideal number. The reason is that most of the I-E pairs selected in CB-STA do not follow the tunnel length constraint.

Fig. 9 compares different blocking probability of the WTA and CB-STA under different load  $\rho$ . The relaxed CB-STA relaxes the length constraint  $D$  in CB-STA. More specifically, in relaxed CB-STA, tunnels with lengths between  $D-1$  and  $D+1$  are permitted to be allocated. Therefore, more useful tunnels can be allocated in relaxed CB-STA than in CB-STA. The following three combinations of switching type are examined:  $1F1B3L$ ,  $1F2B2L$  and  $2F2B1L$ . The results show that WTA has the lowest blocking probability in all switching type combinations. The reason is that WTA allocates more tunnels that comply with length constraint while in CB-STA and relaxed CB-STA, length constraint is not carefully considered in their I-E pair selection stages.

PC-WTA outperforms WTA when each node in the MG-OXC network has only limited wavelength-switching ports (in Fig. 10 (a)). That is because tunnels in PC-WTA are only allocated between nodes that have sufficient wavelength-switching ports. The link capacity and wavelength-switching ports are more efficiently utilized since most of them are consumed by the auxiliary links with higher weights. However, when there are sufficient wavelength-switching ports, performance of PC-WTA is the same as WTA (i.e., performance curves of the two algorithms in Fig.10 (b) and (c) overlaps).

## 6. CONCLUSION

In this paper, we consider the static tunnel allocation problem in the MG-OXC networks that employ a three-stage multiplexing scheme of fiber, waveband and wavelength. The previous work CB-STA does not consider the tunnel length constraint during the I-E pair selection stage, resulting in few tunnels being allocated during the tunnel allocation stage. We propose a novel auxiliary graph model for our heuristics, Weighted Tunnel Allocation (WTA) and Port-Constraint Weighted Tunnel Allocation (PC-WTA), to improve CB-STA. In WTA, tunnel allocation is only attempted for the auxiliary links, whose physical hop distances comply with the length constraint. PC-WTA furthermore, takes wavelength-switching ports into consideration while allocating tunnels. The simulation results show that WTA outperforms CB-STA in all switching type combinations. Besides, PC-WTA has lower blocking probability than WTA when there are limited wavelength-switching ports at each node in MG-OXC networks.

## ACKNOWLEDGEMENTS

This work is supported by National Science Council under Grant Nos. NSC 92-2213-E-009-068 and NSC 91-2218-E-009-016.

## REFERENCES

- [1] P. -H. Ho and H. Mouftah, "Routing and Wavelength Assignment with Multigranularity Traffic in Optical Networks", *IEEE Journal of Lightwave Technology*, Vol. 20, No. 8, Aug. 2002, pp. 1992-1303.
- [2] K. Harada, K. Shimizu, T. Kudou, and T. Ozeki, "Hierarchical optical path cross-connect systems for large scale WDM networks," in *Proc. Optical Fiber Communications (OFC'99)*, Vol. 2, Feb. 1999, pp. 356-358.
- [3] L. Noirie, M. Vigoureux, and E. Dotaro, "Impact of intermediate traffic grouping on the dimensioning of multi-granularity optical networks," in *Proc. Optical Fiber Communications (OFC'01)*, Vol. 2, March 2001, pp. TuG3.1-TuG3.3.
- [4] M. Lee, J. Yu, Y. Kim, C.-H. Kang, and J. Park, "Design of hierarchical crossconnect WDM networks employing a two-stage multiplexing scheme of waveband and wavelength," *IEEE Journal on Selected Areas in Communications*, Vol. 20, Jan. 2002, pp. 166-171.
- [5] X. Cao, V. Anand, Y. Xiong and C. Qiao, "Performance Evaluation of Wavelength Band Switching in Multi-fiber All-Optical Networks," in *Proc. IEEE Infocom*, Vol. 3, Mar. 2003, pp. 2251-2261.
- [6] X. Cao, V. Anand and C. Qiao, "Multi-Layer versus Single-Layer Optical Cross-connect Architectures for Waveband Switching", *IEEE Infocom'04*, 2004

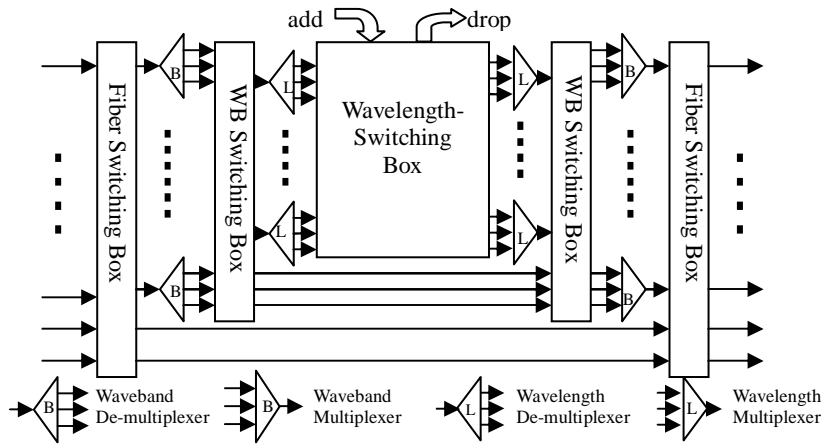

Fig. 1 Architecture of an MG-OXC.

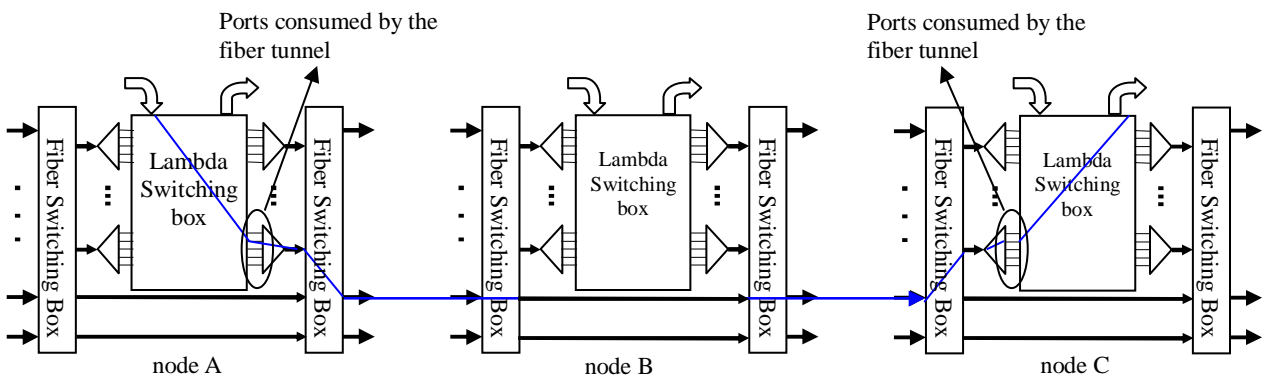

Fig. 2 MG-OXCs with two switching tiers of wavelength-switching and waveband-switching.

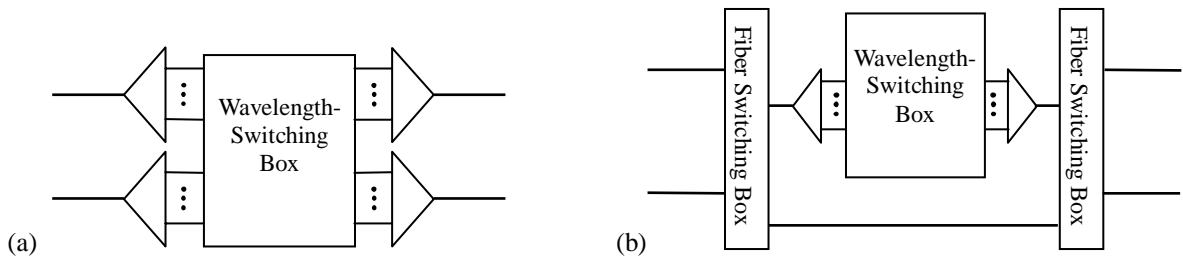

Fig. 3 (a) Traditional OXC. (b) MG-OXC.

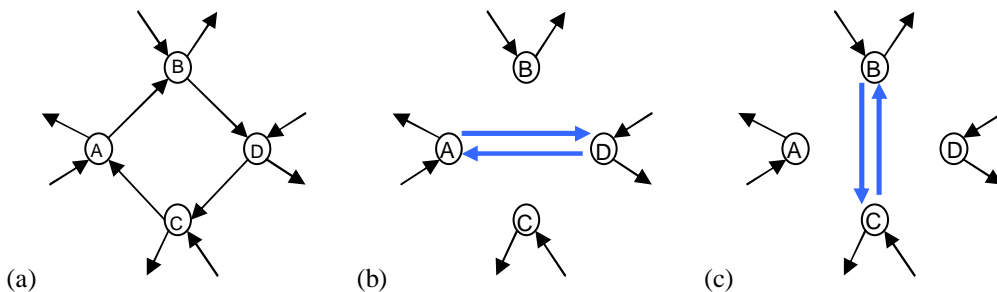
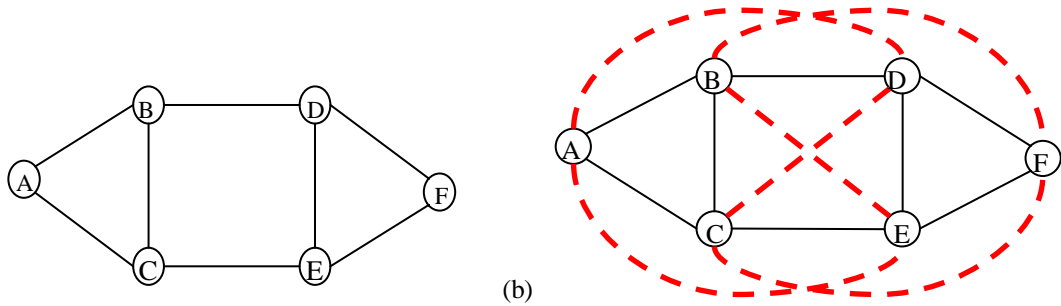

Fig. 4 (a) Physical links to allocate tunnels. (b) and (c) Two ways of tunnel allocation.



(a) (b)  
 Fig. 5 An example of auxiliary graph. (a) Network topology with average hop distance 2. (b) Corresponding auxiliary graph.

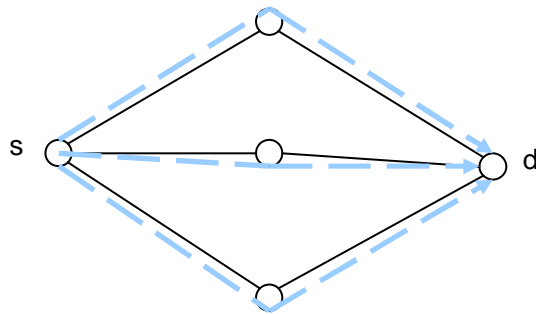

Fig. 6 An example of deriving the weight for each link in the auxiliary graph.

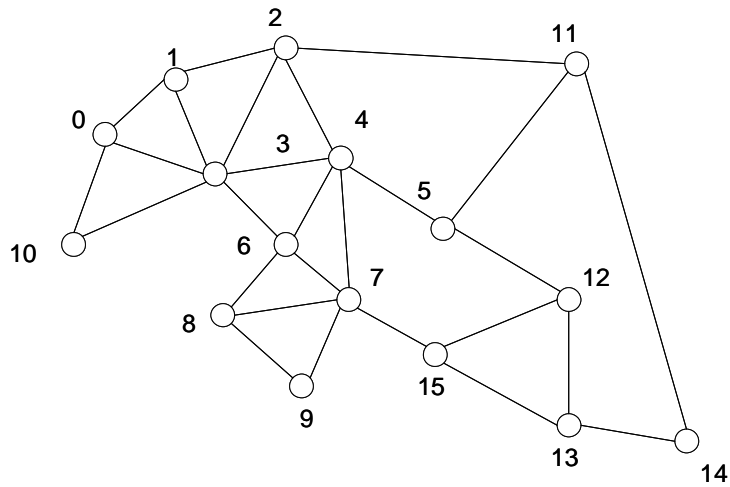

Fig. 7 The 16-node network for this simulation.

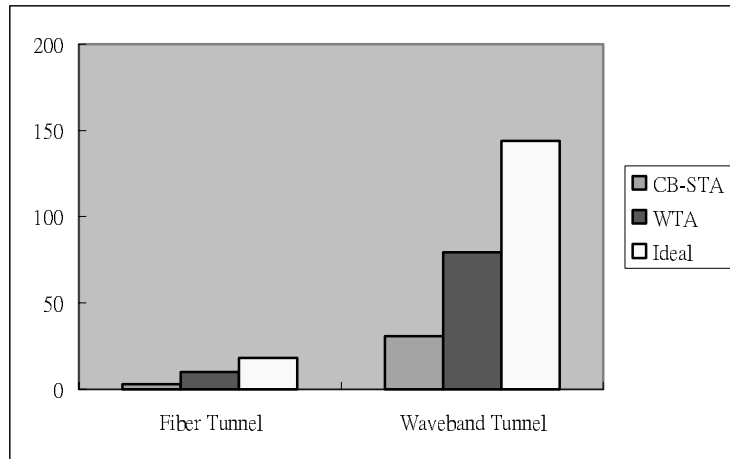
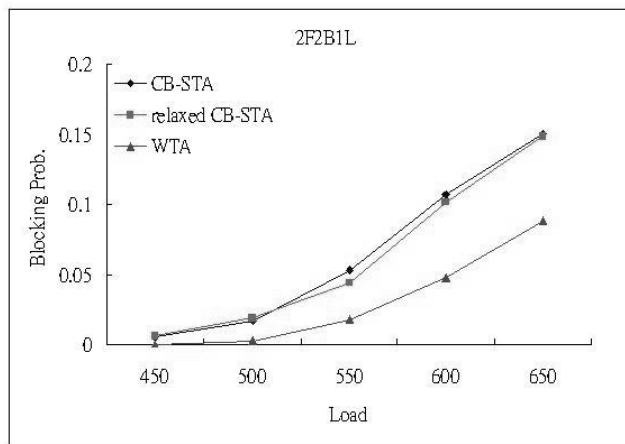
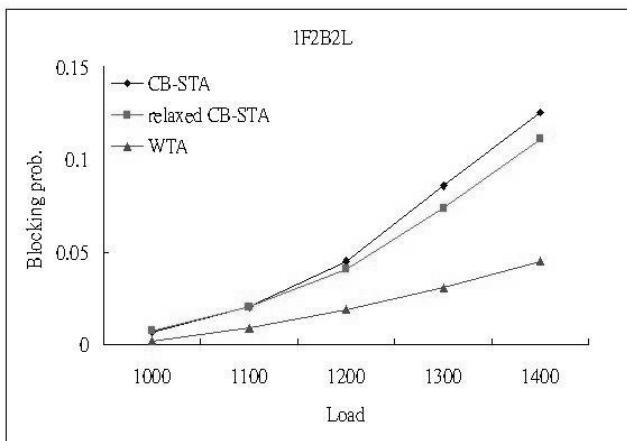

Fig. 8 Comparison of the number of allocated tunnels in WTA and CB-STA (without performing their makeup processes), and the ideal numbers under  $1F2B2L$ .



(a)



(b)

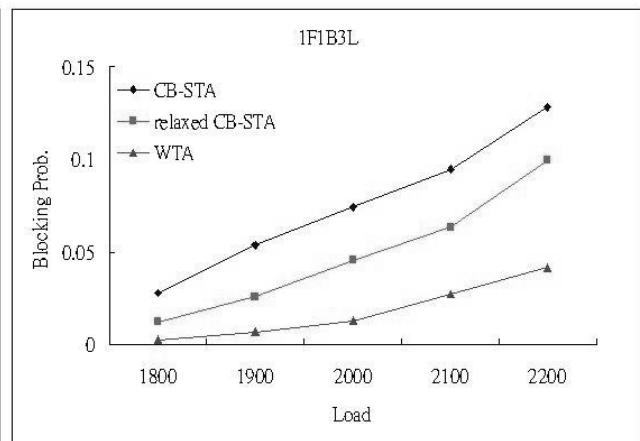

(c)

Fig. 9 Comparison of blocking probability vs. load for WTA and CB-STA on the 16-node topology.



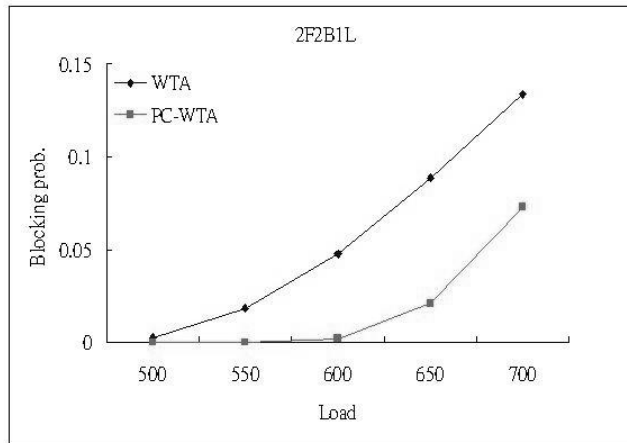

(a)

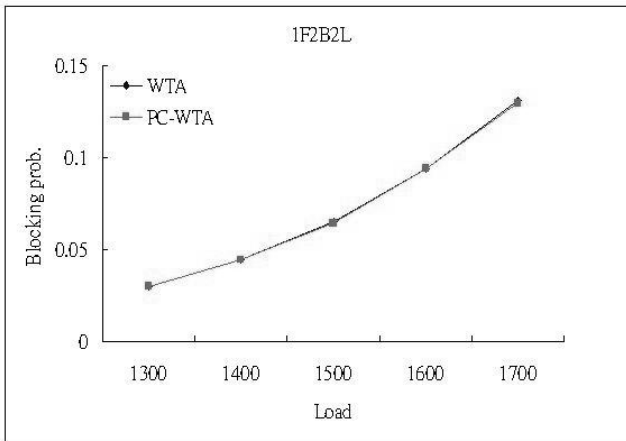

(b)

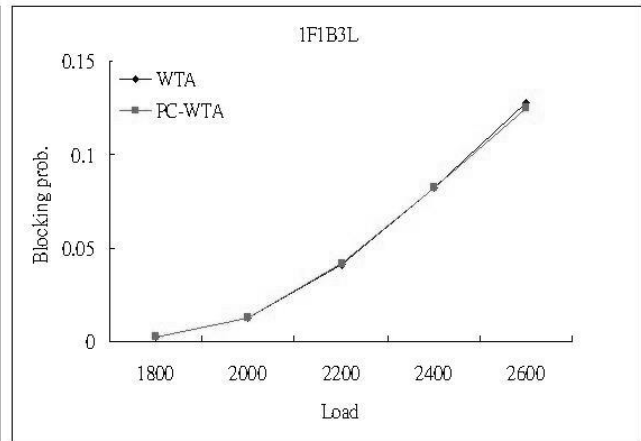

(c)

Fig. 10 Comparison of blocking probability vs. load for WTA and PC-WTA on the 16-node topology.