

# Using Precoding Technique to Reduce the BER Penalty of an $M$ -QAM Channel in Hybrid AM-VSB/ $M$ -QAM Subcarrier Multiplexed Lightwave Systems

Pi-Yang Chiang, Cherng-Chyi Hsiao and Winston I. Way

Department of Communication Engineering

National Chiao-Tung University

Hsinchu, Taiwan, R.O.C.

Phone: 886-3-572-9138

Fax: 886-3-571-8870

e-mail: wiway@cc.nctu.edu.tw

## ABSTRACT

We propose and verify through computer simulations the use of a precoding technique to eliminate the nonlinear distortions (NLD's) in an  $M$ -QAM channel which is transported along with multiple AM-VSB channels by a laser diode. We show that the precoding technique can completely remove the clipping-induced bit-error-rate (BER) floor at a cost of a 3 dB signal-to-noise ratio (SNR) reduction.

## I. INTRODUCTION

Using a single laser diode to transport both AM-VSB and  $M$ -QAM channels is a cost-effective approach to employ for both today's analog video services and tomorrow's digital multimedia services. However, in this approach, the BER of  $M$ -QAM channels can be severely degraded by laser-clipping-induced impulsive noise.

In the past few years, several techniques have been proposed to overcome this problem. The first is the pre-clipping method [1][2], which used a limiter before the laser diode so that the laser diode will not clip, and a low pass filter or a band stop filter after the limiter to remove the clipping-induced NLD's. The drawback of this technique is that the BER performance of the  $M$ -QAM channel depends critically on the filter design which may not be practically feasible. The second method is to use the combination of a clipping reduction (CR) circuit and a Reed-Solomon forward-error-correction (RS-FEC) codec [3]. The CR circuit is used to detect the clipping events in advance and then instantaneously increase the bias current of the laser diode to avoid laser clipping. However, it was also observed in [3] that CR circuit or RS-FEC alone cannot reduce the  $M$ -QAM BER satisfactorily.

In this paper, we propose a novel precoding technique to solve the problem. This technique was previously adopted by digital spectrum-compatible high definition television broadcast system to reject co-channel NTSC visual, color, and aural carriers [4], and can be realized in an  $M$ -QAM modem by digital signal processing techniques. We have modified the precoding technique in [4] to reject discrete interferences located at fixed frequencies such as  $6n+1.25$  MHz where composite-triple beat (CTB) occurs ( $n$  is an integer), and  $(6n+1.25)\pm 1.25$  and  $(6n+1.25)\pm 0.75$  MHz where composite second-order (CSO) beat occurs [5].

## II. THE PRECODING TECHNIQUE

Fig.1(a) shows the received  $M$ -QAM spectrum interfered by CSO's and CTB due to laser clipping or other nonlinear mechanisms. A possible method to remove the CSO's and CTB is to utilize a comb filter with notches at  $6n+0.25k$  MHz where  $0 \leq k \leq 23$  (Fig.1(b)). This comb filter, which has a transfer function  $H_C(f) = 1 - e^{-j2\pi f T}$  with a delay time  $T = 4 \mu\text{s}$ , must be used in combination with a pre-equalizer (Fig.1(c)) whose transfer function is given by  $H_e(f) = 1/H_C(f)$  in order to have an overall flat frequency response. However, the pre-equalizer with feedback may become unstable (e.g., when the input signal has a DC component). In addition, the combiner in the pre-equalizer increases the number of possible levels in case of quantized inputs and the required dynamic range in case of analog inputs.

A modification of Fig.1(c) by utilizing modulo reductions [4], shown in Fig.1(d), can avoid all the above disadvantages and still retain the operation of the comb filtering. The output of the precoder is now confined to the same range of the input data by a modulo operator. Therefore, the precoded data will be stable and has the same dynamic range as the input data.

In the receiver, another modulo operator at the output of the comb filter is required to recover the original data. To show that the overall coding system works, assume that the input data symbol  $a_n \in \{0, 1, 2, \dots, L-1\}$ , i.e. an  $L$ -pulse amplitude modulation ( $L$ -PAM) signal, where  $L$  is a positive integer. The precoded symbol  $b_n$  is then given by

$$b_n = (a_n + b_{n-D}) \bmod L \quad (1)$$

where  $D$  is the number of delayed symbols. Similarly, after the comb filter and the modulo operator, the recovered symbol  $d_n$  is

$$d_n = (b_n - b_{n-D}) \bmod L \quad (2)$$

After combining (1) and (2), we obtain

$$(a_n - d_n) \bmod L = 0 \quad (3)$$

Since both  $a_n$  and  $d_n$  are elements of the set  $\{0, 1, 2, \dots, L-1\}$ , we can conclude that  $a_n = d_n$ . Therefore, once an end-to-end transmission is established, the decoded data symbol will be the same as the original data symbol without any timing delay.

We note that the only penalty of the precoding technique is the 3 dB degradation in SNR [4]. This is because that the equivalent noise power after the comb filter is

$$\frac{N_0}{2} \int_{-B}^B |H_c(f)|^2 df = \frac{N_0}{2} \int_{-B}^B |1 - e^{-j2\pi f T}|^2 df = 2N_0 B \quad (4)$$

where  $B$  is the equivalent noise bandwidth of the receiver *without* comb filter, and  $N_0/2$  is the two-sided spectral noise density. Therefore, when the comb filter is added to the system, the equivalent noise power is twice of the original equivalent noise power of  $N_0 B$ . However, for the transmitted data, the output of the modulo operator ( $d_n$ ) and the input of the comb filter ( $b_n$ ) have the same power level. Consequently, a 3 dB SNR reduction results.

### III. COMPUTER SIMULATIONS

The computer simulation system block diagram is shown in Fig.2, where the nonlinear transfer function represents a laser diode with an arbitrary L-I curve. The simulation parameters and conditions are as follows: (1) The I/Q data were precoded with  $L = 8$  (i.e., 8-PAM) and  $D = 20$  (i.e., a delay of 20 symbols). (2) 42 random-phased unmodulated carriers (from 55.25 MHz to 307.25 MHz) were combined with an up-converted 5-Msps 64-QAM signal centered at 417 (=6×69+3) MHz, and the simulation results were averaged over 6000 different phase combinations of the 42 AM channels. The reason why we chose 417 MHz as the center frequency of the QAM channel ( $f_c$ ) is to calibrate our simulation results with those of a theoretical analysis [6]. In general, the center frequency of a QAM channel can be allocated at  $6n+3+m \times f_d$  MHz, where  $m$  is an integer and  $f_d$  is the frequency separation between notches, in order to suppress all the CTB and CSO's. (3) The sampling frequency was 5 GHz which is high enough to remove the spectral aliasing error. (4) Root raised-cosine (RRC) filters with a roll-off factor of 0.2 were used as band-limiting pulse-shaping filters in the transmitter, and as matched filters in the receiver, respectively. (5) In the receiver, ideal carrier and timing recoveries were assumed.

Note that we are concerned with only the effect of AM-channel-generated NLD's in an  $M$ -QAM channel, therefore no noise was added to the transmission link in our simulation, and the deviations of the decoded I/Q data from the correct values were due to NLD's and limited inter-symbol interference only. In other words, our simulation generates a noiseless but distorted waveform at the receiver (after modulo 8 operation), while in the BER estimator, we add an equivalent Gaussian noise with a known probability density function (pdf) so that one can *calculate* the BER with an analytical formula. This simulation technique, which saves significant amount of simulation time as compared to conventional Monte Carlo simulation, is known as the *quasianalytical* (QA) simulation [7]. The pdf of the Gaussian noise has a mean given by the amplitude of the decoded I or Q datum, and a variance given by the equivalent noise power in the receiver.

Generally speaking, the number of the simulated pseudo-random symbols in a QA simulation should be at least  $M^d$ , where  $M$  is the size of the signaling alphabet, and  $d$  is the memory of the system in number of symbols [7]. However, in a hybrid AM-VSB/ $M$ -QAM system, it is the clipping events rather than the  $M$ -QAM symbol patterns that

determine the BER of an  $M$ -QAM channel. Therefore, given one of the 6000 random phase combinations of the 42 AM channels, we used up to 500 symbols to estimate the resultant 64-QAM BER [8], i.e., each point on a BER curve is the average result of  $6000 \times 500$  symbols. If additional distortions such as carrier phase error and symbol timing error were to be included, much more than 500 symbols must be used for each combination [8][9]. In addition, when the 42-channel phases are coherent enough to induce clipping, the dominant time interval between clipping events is  $4 \mu\text{s}$  [6], and therefore 200 symbols with  $0.2 \mu\text{s} \times 200 = 40 \mu\text{s}$  duration can include about 10 dominant clipping intervals. Note that the average of BER over 6000 different random phase sets is necessary when clipping probability is low.

Fig.3 shows the BER versus rms optical modulation index (OMI) of the 64-QAM channel ( $m_q$ ). As a calibration of our simulation technique, we first note that if the precoding technique is not used, the simulated BER performances due to laser clipping (solid squares and circles) are about the same as those calculated from theory (lines) [6] for total rms OMI  $\mu = 0.275$  and  $0.229$ , respectively. When the precoding technique is used, it is observed that the noise floors are completely removed for both  $\mu$ 's (open circles). The deviation from the baseline BER curve is due to the 3 dB SNR degradation of the comb filtering, as was explained in Sec.II.

The experimental results which used (204,188) RS-FEC and  $\mu = 0.253$  [3] are also shown in Fig.3 for comparison. We can see that there still exists a BER floor when using this RS-FEC. In contrast, when precoding technique is used, the BER is decreased significantly even when a larger  $\mu$  of  $0.275$  is used.

Ideally, all discrete CSO/CTB falling into the notches of the comb filter can be completely removed. In practical systems, however, all carriers have certain amount of phase noise and could cause CSO/CTB spread wider in the frequency domain. This CSO/CTB spread may degrade the performance of the precoding technique. The results of our computer simulations, also shown in Fig.3, tell us that even when the phase noise of each 42 AM carrier is as high as  $-40 \text{ dBc}$  @  $10 \text{ KHz}$  offset, the BER improvement due to precoding remains about the same. Only when the phase noise of each AM carrier is increased to  $-30 \text{ dBc}$  @  $10 \text{ KHz}$  offset do we see apparent BER performance degradation, but still with no error floor. The reason why the precoding technique is not sensitive to AM carrier phase noise is because the notches in a comb filter are deep and wide enough to eliminate most of the spread CTB/CSO's. Therefore, we conclude that the typical phase noise associated with AM carriers ( $< -70 \text{ dBc}$  @  $10 \text{ KHz}$  offset) will not degrade the BER performance in using the proposed precoding technique.

The proposed technique can also be applied to the IRC frequency plan systems, as were verified in a separate simulation with  $f_c = 416.5 \text{ MHz}$  and a delay  $D = 4$ . The shorter delay resulted in a slightly better BER performance due to the wider notch filtering. Similarly, the technique can be used in HRC frequency plan systems with properly chosen  $f_c$  and  $D$ .

Since the comb filter at the receiver can reject CSO's and CTB due to strong AM signals, it is clear that the precoding technique can also be applied to suppress CSO/CTB due to other NLD-generation mechanisms such as fiber dispersions or optical reflections in hybrid AM-VSB/ $M$ -QAM SCM lightwave systems.

#### IV. CONCLUSIONS

A novel precoding technique which can be used to eliminate CTB/CSO's in hybrid AM-VSB/ $M$ -QAM SCM lightwave systems is proposed and its feasibility is verified by computer simulations. The BER floor due to laser clipping-

induced CSO/CTB in an  $M$ -QAM channel can be completely removed by using the precoding technique, even when the phase noise in each AM-VSB carrier is as large as  $-40$  dBc @ 10 KHz offset. Furthermore, this precoding technique can be used to eliminate CTB/CSO's induced by optical fiber dispersions, optical reflections, etc., and presents neither bandwidth overhead nor timing delay of the transported information. The only penalty in using this technique is that there is a 3 dB SNR degradation due to the comb filtering.

## V. REFERENCES

- [1] A. Kanazawa, "Pre-clipping method to reduce clipping-induced degradation in hybrid analog/digital subcarrier-multiplexed optical transmission systems," *IEEE Photon. Technol. Lett.*, vol.7, no.9, pp.1069-1071, Sep., 1995.
- [2] Q. Pan and R. J. Green, "Performance analysis of preclipping AM/QAM hybrid lightwave systems," *J. Lightwave Technol.*, vol.15, No.1, pp.1-5, Jan. 1997.
- [3] C. Y. Kuo and S. Mukherjee, "Clipping reduction for improvement of analog and digital performance beyond clipping limit in lightwave CATV systems," *OFC'96*, postdeadline paper PD18-1, San Jose, CA, Feb., 1996.
- [4] C. Eilers and P. Fockens, "The DSC-HDTV interference rejection system," *IEEE Trans. Consumer Electron.*, vol.38, no.3, pp.101-106, Aug. 1992.
- [5] J. L. Thomas, *Cable Television Proof-of-Performance*, Englewood Cliffs, NJ: Prentice-Hall, 1995.
- [6] S. Lai and J. Conradi, "Theoretical and experimental analysis of clipping-induced impulsive noise in AM-VSB subcarrier multiplexed lightwave systems," *J. Lightwave Technol.*, vol.15, no.1, pp.20-30, Jan. 1997.
- [7] M. C. Jeruchim, P. Balaban, and K. S. Shanmugan, *Simulation of communication systems*, New York: Plenum Press, 1992.
- [8] F. Gagnon, N. Batani, R. Bourdeau, and J. Belzile, "On a complete simulation model for the design of high-speed digital radios," *IEEE J. Select. Areas Commun.*, vol.15, no.4, pp.685-693, May 1997.
- [9] W. H. Tranter and C. R. Ryan, "Simulation of communication systems using personal computers," *IEEE J. Select. Areas Commun.*, vol.6, no.1, pp.13-23, Jan. 1988.

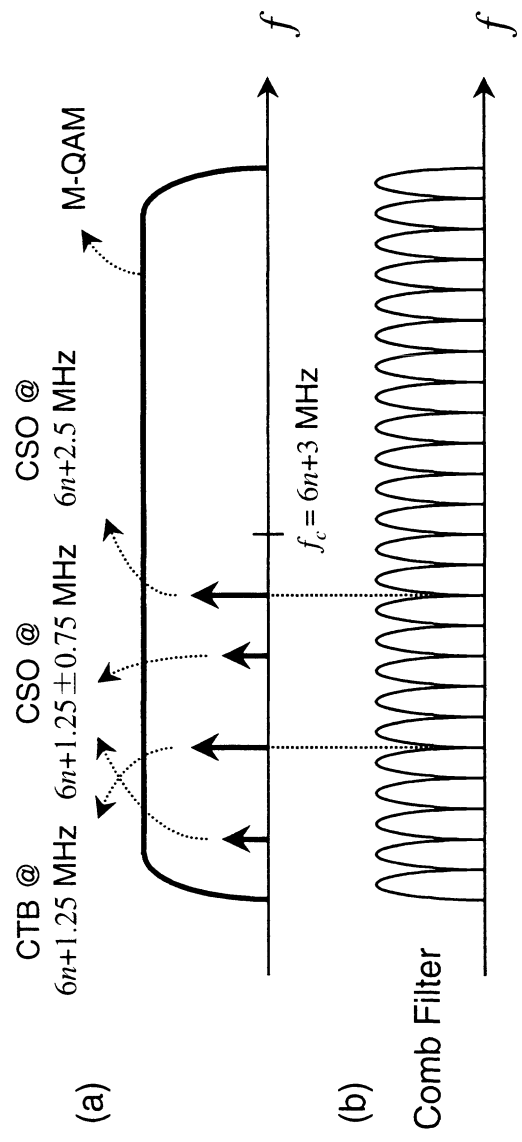

Fig.1 (a) Frequency locations of CSO's and CTB in an M-QAM Channel whose center frequency  $f_c$  is at  $(6n+3)$  MHz. (b) A comb filter with notches at  $6n+0.25k$  MHz, where  $0 \leq k \leq 23$

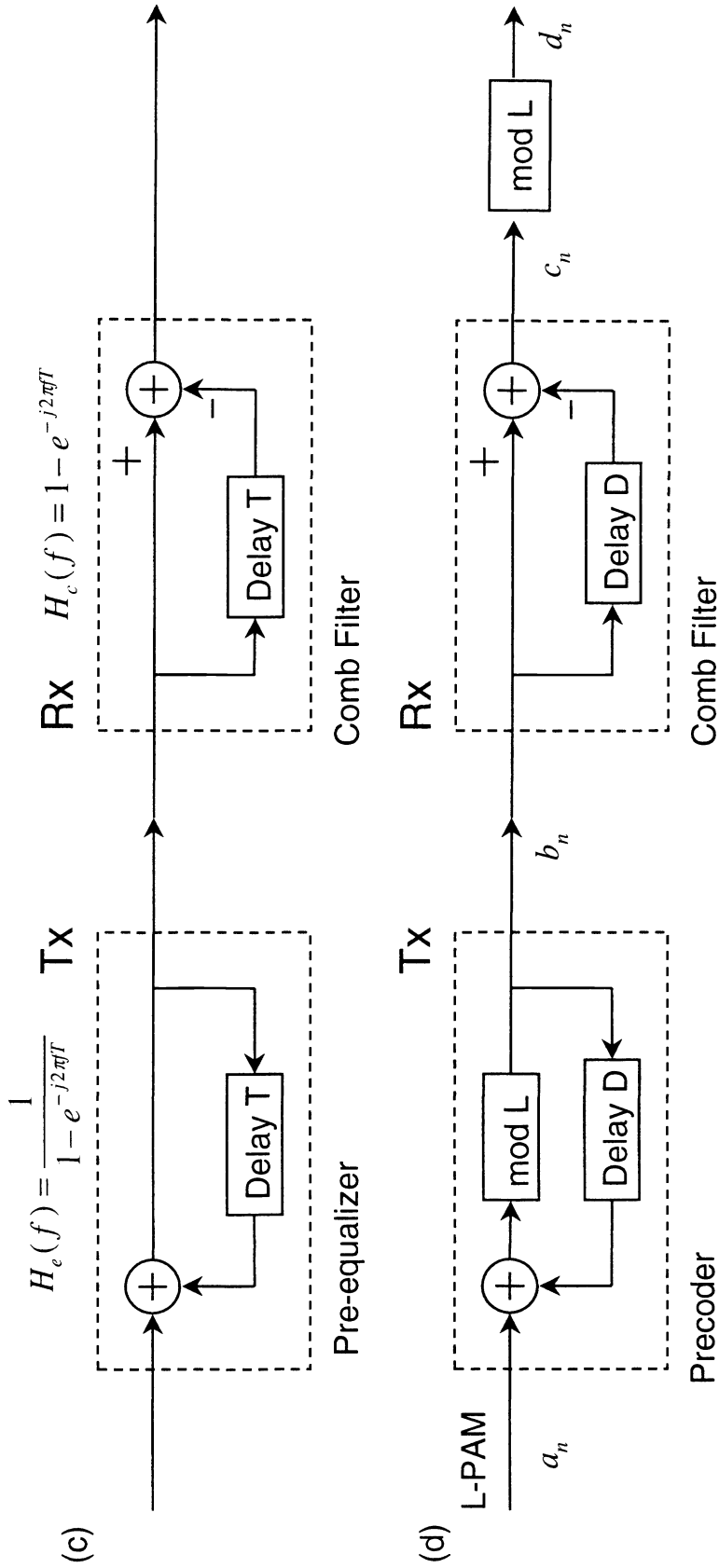

Fig.1 (c) A pre-equalizer and a comb filter, with their respective transfer function shown.  
 (d) A precoder, a comb filter, and a modulo operator.

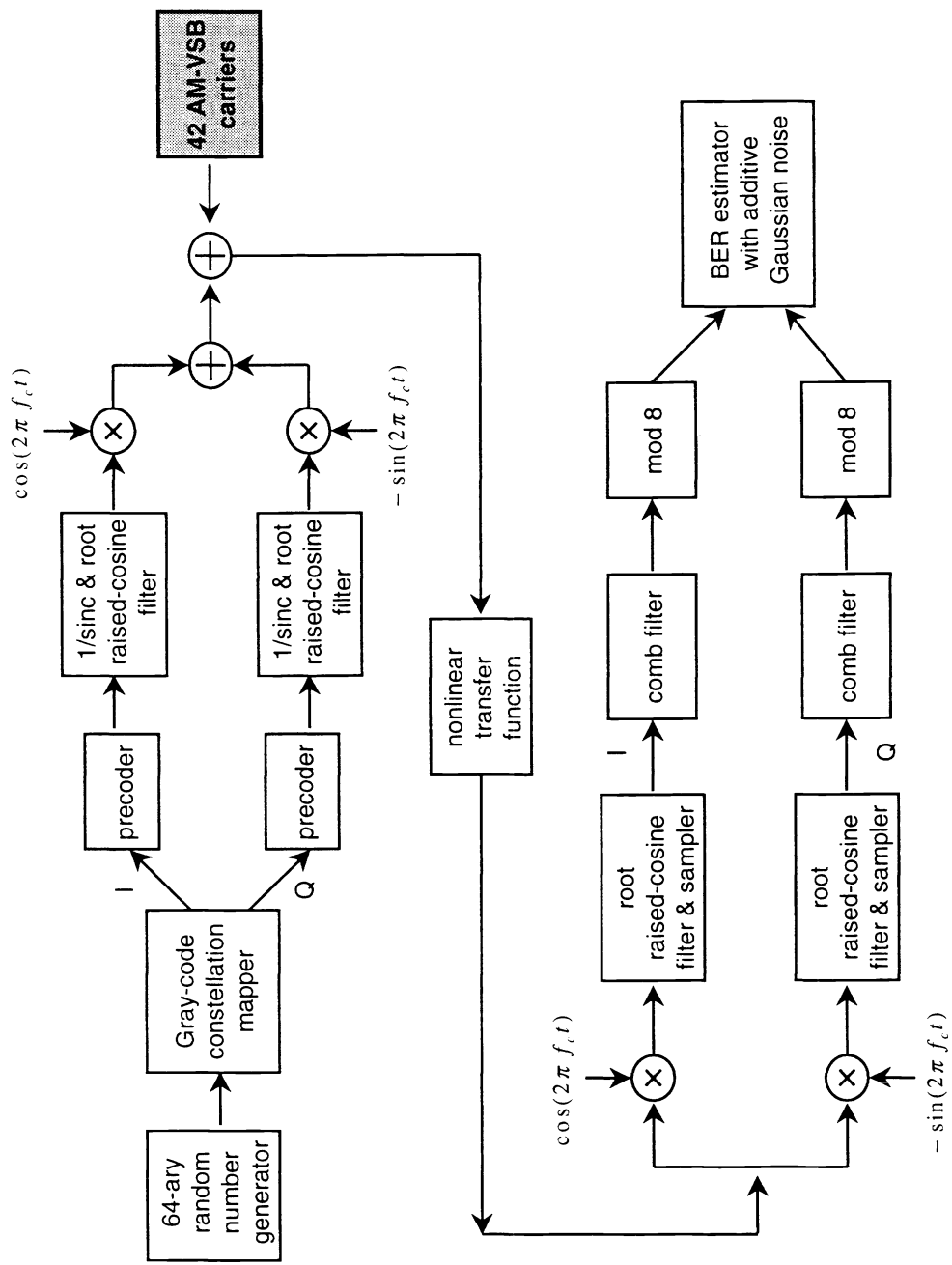

Fig.2 Simulation block diagram and the hybrid AM-VSB/64-QAM signal power spectral density (PSD).



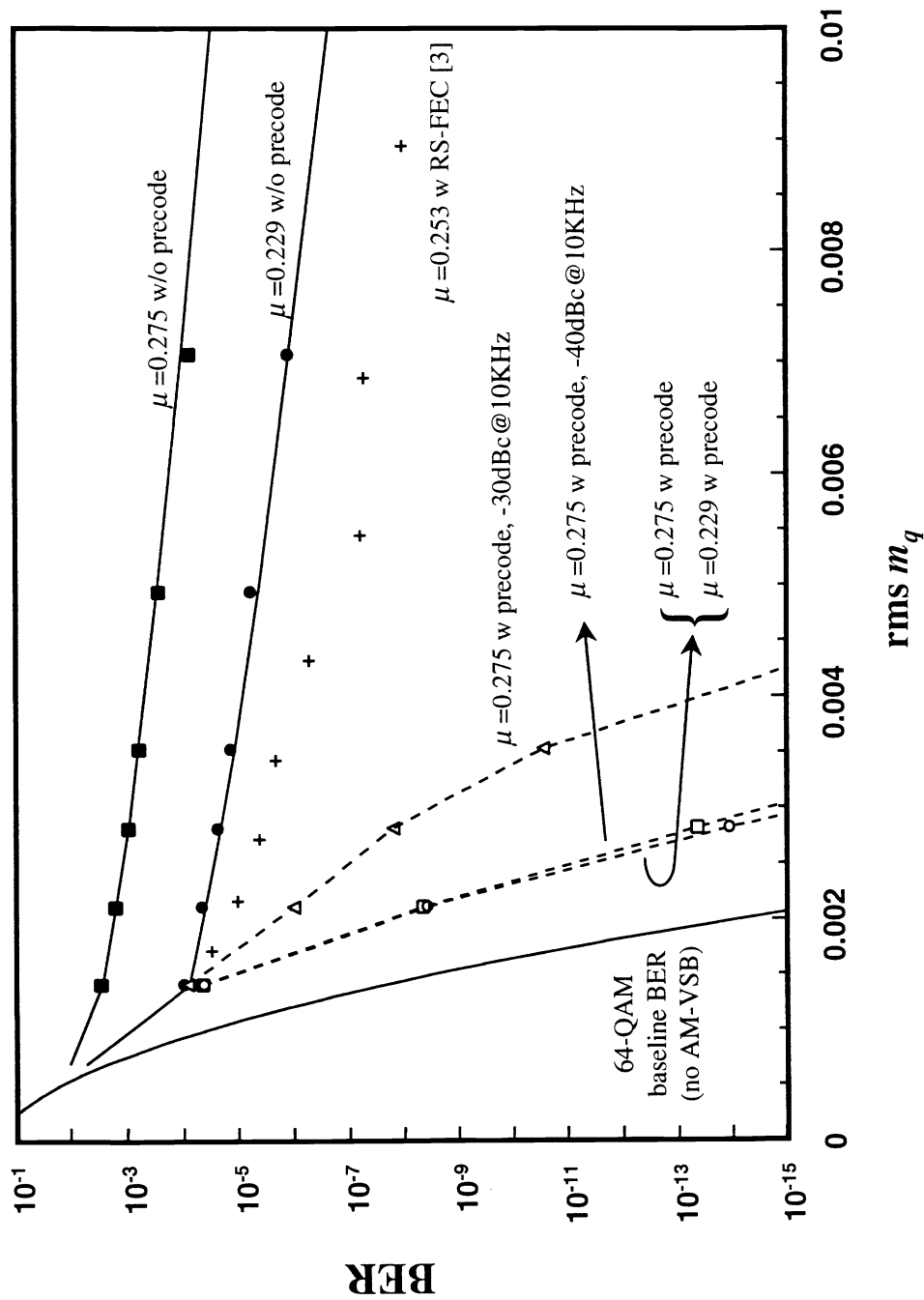

Fig.3 64-QAM BER vs. its rms OMI  $m_q$ . Three solid lines are theoretical results for  $\mu=0.275, 0.229$  and without AM-VSB channels. Solid/open square and circles are simulated results without/with precoding technique for both  $\mu=0.275$  and  $0.229$ . Open squares and triangles are simulated results with precoding technique for  $\mu=0.275$ , and with a phase noise of  $-30\text{ND}-440\text{dBc}@10\text{kHz}$  offset in each AM carrier, respectively. Plus signs are experimental results from [3]. The parameters used in the simulation are based on [8].