

# The experimental study on biogas power generation enhanced by using waste heat to preheat inlet gases

Tsung-Han Lee, Sheng-Rung Huang, Chiun-Hsun Chen\*

Department of Mechanical Engineering, National Chiao Tung University, 1001 University Road, Hsinchu 300, Taiwan, ROC

## ARTICLE INFO

### Article history:

Received 13 October 2011

Accepted 18 June 2012

Available online 31 July 2012

### Keywords:

Biogas

Biogas generator

Methane concentration

Inlet gas temperature

## ABSTRACT

A 30 kW generator at the Taiwan Sugar Swine Farm in Taichung was used to collect data intended for long-term electricity generation. This three-part experimental study utilized a biogas with a 73% methane concentration. First, the effect of the biogas supply rate on generator performance at different excess air ratios is investigated. Second, the results from this study are compared with results obtained from work performed on a biogas with a 60% methane concentration. Finally, for a 73% methane concentration biogas, the effect on generator performance of preheating the inlet gas to different temperatures is investigated by applying a waste-heat recovery system.

Power generation increases with increasing biogas methane concentration, except when  $\lambda$  (excess air ratio)  $< \sim 0.85$ . However, thermal efficiency increases with increasing methane concentration only when  $\lambda > \sim 0.95$ , although on the relatively rich side ( $\lambda < 0.95$ ), there is no benefit. The improved generator performance obtained by preheating the inlet gas is apparent when the excess air ratio is relatively high, such as when  $\lambda > 1.3$ .

© 2012 Elsevier Ltd. All rights reserved.

## 1. Introduction

Global warming and the energy shortage crisis are currently serious problems. Animal manure from farms can produce biogas after anaerobic treatment, the main components of which are methane (CH<sub>4</sub>) and carbon dioxide (CO<sub>2</sub>), with relatively small amounts of nitrogen (N<sub>2</sub>), hydrogen (H<sub>2</sub>), ammonia (NH<sub>3</sub>), hydrogen sulfide (H<sub>2</sub>S), and organic compounds. Because methane is a flammable fuel, a biogas containing methane can be used as a renewable fuel.

In this study, a desulfurized biogas was used to operate a biogas engine at different monitoring parameters to produce electricity. The methane concentration in biogas can be affected by the concentration of organics in wastewater. Therefore, the first task of this study was to test the effect of different methane (CH<sub>4</sub>) concentrations in biogas on the generator performance with different fuel flow rates and excess air ratios. The second task was to build a waste-heat recovery system to preheat the inlet gases (the mixture of biogas and air) at different temperatures and then to analyze the influence of preheating on the generator performance.

Chen et al. [1] analyzed the status of renewable energy, such as biomass energy, solar energy, wind power, geothermal energy, and hydropower, in Taiwan. They indicated that renewable energy has not yet fully developed there because fossil energy is less expensive. However, renewable energy will become more competitive in the energy market because the Legislative Yuan passed the “Renewable Energy Development Bill” in June 2009. In addition, the promotion of renewable energy will offer positive economic benefits to related industries.

To analyze the potential use of biogas as bio-energy, Rasi et al. [2] investigated the difference in the components of biogas found in a landfill, a sewage-treatment-plant sludge digester, and a farm biogas plant. They found that biogas compounds vary with different biogas plants: carbon dioxide ranges from 36% to 41%, methane from 48% to 65%, nitrogen from 1% to 17%, and oxygen is less than 1%. Sewage digester biogas contains the highest methane content; landfill biogas contains the lowest methane and the highest nitrogen contents in winter. The total volatile organic compounds (TVOCs) range from 5 to 268 mg/m<sup>3</sup>, and the farm biogas plant has the lowest TVOCs. Sulfur compounds are found in all three places.

Tsai and Lin [3] surveyed bio-energy generated by livestock manure management in Taiwan. From the farm scale of over 1000 heads swines, which is a realistic representation of the total swine population, the analysis showed several benefits. The study showed that bio-energy offered a reduction in the emission of methane by 21.5 Gg; the generation of a total  $7.2 \times 10^7$  kW-h electricity per year,

\* Corresponding author. Tel.: +886 3 5725634; fax: +886 3 5728504.  
E-mail address: [chchen@mail.nctu.edu.tw](mailto:chchen@mail.nctu.edu.tw) (C.-H. Chen).

which is equivalent to an electricity cost savings of  $USD 7.2 \times 10^6$ ; and the mitigation of 500 Gg per year of carbon dioxide.

Tippayawong et al. [4] used a mixture of biogas and diesel fuel to feed a small diesel engine and then examined its endurance over 2000 h. The results showed that the engine had a 7% increase in power output and higher efficiency compared to that of normal diesel operation.

Porpatham et al. [5] tested the effect of CO<sub>2</sub> concentration in biogas on the performance of a constant-speed-spark-ignition (SI) engine. A limewater scrubber was used to absorb the carbon dioxide (CO<sub>2</sub>) in the biogas. They found that when the carbon dioxide (CO<sub>2</sub>) in biogas is reduced from 41% to 30%, engine performance is improved by 20%, unburned hydrocarbons (HC) are reduced, and the lean limit of combustion is extended. However, such improvements occur only in the lean-fuel region. An increase in the methane concentration plays a significant role in the lean-fuel region because the flame velocities are low in that region. There is no benefit to power or efficiency on the rich-fuel side due to incomplete combustion of the engine.

Abd-Alla et al. [6] operated a high-speed, indirect-injection, dual-fuel engine, using methane or propane as the main fuel and diesel fuel as the pilot fuel. The effects of exhaust gas recirculation (EGR), diluents admission (N<sub>2</sub> and CO<sub>2</sub>), and intake-air temperature on combustion and emissions were investigated. The results showed that the admission of diluents reduces NO<sub>x</sub> emissions, and the higher intake temperature increases NO<sub>x</sub> emissions but reduces unburned hydrocarbon emissions.

Semin et al. [7] compared the cylinder pressure and maximum pressure of a compressed natural gas engine with the pressures of a standard diesel engine. The results showed that the transformation of a diesel engine into a compressed natural gas engine decreases the cylinder pressure.

Ga et al. [8] used a biogas-gasoline hybrid engine to test the conversion efficiency of biogas. The results showed that 1 m<sup>3</sup> of biogas can produce 1 kW-h of electricity and prevent the emission of 1 kg of CO<sub>2</sub> into the atmosphere.

Huang and Crookes [9] simulated biogas by diluting natural gas with CO<sub>2</sub> and then used it as the fuel in a single-cylinder-spark-ignition engine. The fraction of CO<sub>2</sub> in the simulated biogas ranged from 0 to approximately 40%. Increasing the fraction of CO<sub>2</sub> in biogas can lower NO<sub>x</sub> emissions and enable the compression ratio to be increased. However, the cylinder pressure is reduced, resulting in the simultaneous reductions of power and thermal efficiency and the increase of unburned hydrocarbon emissions. Additionally, the CO emissions are low and exhibit little change when running with the fuel-lean mixture. When running with the fuel-rich mixture, the CO emissions increase sharply when the CO<sub>2</sub> fraction is above 30% because of incomplete combustion.

**2. Experimental and methods**

The experimental layout is shown in Fig. 1. The engine was an IVECO 803li06 original four-stroke diesel engine with a total displacement of 2.9 L. It was operated with diesel fuel, using compression to ignite the fuel. To use biogas as the fuel, the compression ignition was replaced with a spark-ignition system in the engine. The airflow meter at the air inlet was an insertion-type VA-400 flow sensor with a range that varied with the installed pipe diameter. The measurement range of the flow sensor was 9–2700 m<sup>3</sup>/h, with an accuracy of approximately ±3% of the measured value. The biogas flow meter at the biogas inlet was a TF-4130-32 thermal-mass flow meter. The measured flow for the biogas produced at the swine farm was generally a mixture of 60% CH<sub>4</sub> and 40% CO<sub>2</sub>. The measurement range of the flow sensor was 0–500 NL/min, with an accuracy of approximately ±2% of the

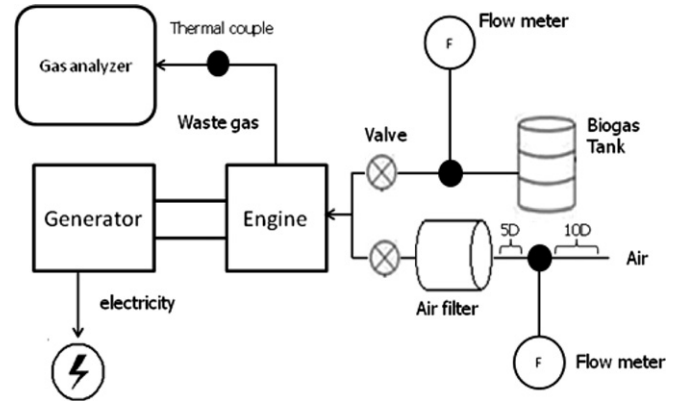

Fig. 1. Experiment layout.

measured value. The gas analyzer at the waste-gas outlet (HM5000) measured the waste-gas component data. This analyzer measured the concentration of oxygen and carbon monoxide and then used that data to deduce the concentration of carbon dioxide. The measurement range of the gas analyzer was 0–25% for O<sub>2</sub>, 0–10% for CO, and 0–20% for CO<sub>2</sub>, each with an accuracy of approximately ± 0.2% and a resolution of 0.1%.

Fig. 2 is the waste-heat recovery system. The heat exchanger follows the exhaust pipe. The waste gases flow into the exchanger and transfer heat to the intake gases (the mixture of biogas and air) that flow in a separate pipe. The heat exchanger preheats the inlet gases to various temperatures. T1 and T2 measure the temperature of the waste gases before and after the heat exchanger, respectively. T3 and T4 measure the intake gases at the inlet and outlet, respectively.

The following calculations include the excess air ratio, thermal efficiency, theoretical mole fraction of CO<sub>2</sub> in waste gas, and the theoretical percentage of consumed CH<sub>4</sub>. These will be used in the analyses of the following experiments.

The air–fuel ratio (AF) is defined as a ratio of the moles of air to the moles of fuel in the combustion process. The stoichiometric reaction for the combustion of methane with standard air is given as:

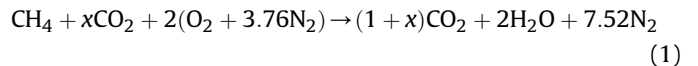

The excess air ratio ( $\lambda$ ) is the ratio of the actual moles of air used to the stoichiometric moles of air, defined as:

$$\lambda = \frac{(\text{mole of air})_{act}}{(\text{mole of air})_{stoch}} = \frac{\left(\frac{\text{mole of air}}{\text{mole of fuel}}\right)_{act}}{\left(\frac{\text{mole of air}}{\text{mole of fuel}}\right)_{stoch}} = \frac{AF_{act}}{AF_{stoch}} \tag{2}$$

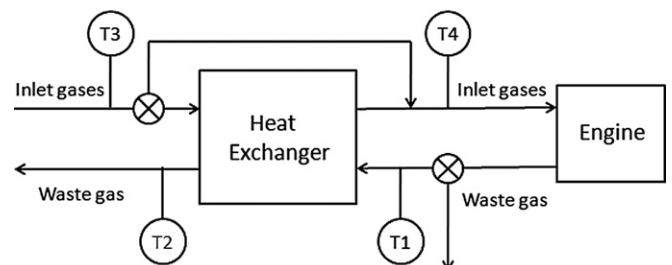

Fig. 2. Waste heat recovery layout.

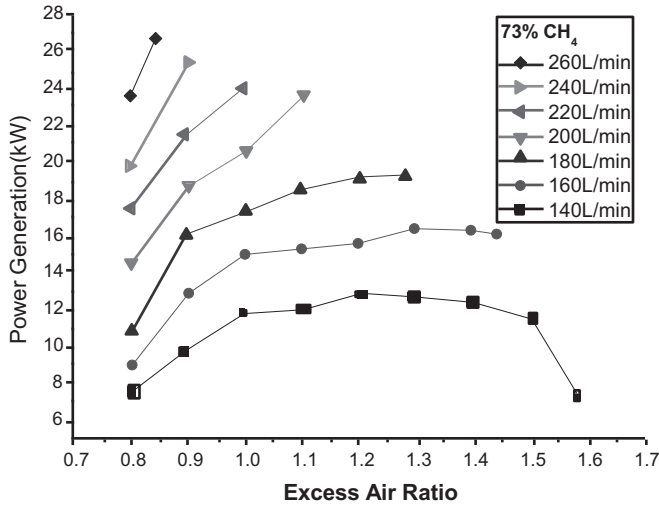

Fig. 3. Power generation vs. excess air ratio at different biogas supply rates.

Note that the actual moles of fuel is equal to the stoichiometric moles of fuel because the fuel-supply rate is fixed in the engine experiments, whereas the air-volume flow rate is varied. As a consequence, the excess air ratio is equal to the ratio of  $AF_{act}$  to  $AF_{stoich}$ . Also,  $\lambda$  is the reciprocal of this equivalence ratio.

Thermal efficiency is a measure of how much energy is converted into electric power, and its formulation is as follows:

$$\text{Thermal Efficiency} = (\text{Power Generation})/(\text{Energy Input}), \quad (3)$$

where “Energy Input” is calculated from the lower heating value (LHV) of methane in the biogas, which is 50,020 kJ/kg. It is expressed as:

$$\text{Energy Input} = \dot{m}_{CH_4} \times \text{LHV of } CH_4 \quad (4)$$

The power generation referenced in this study is the power output of the biogas generator. When the engine drives the generator to work, there is significant heat loss between the generator and the engine; therefore, it is impossible to calculate the exact power output of the engine.

The methane mass flow rate in biogas,  $\dot{m}_{CH_4}$ , is calculated by:

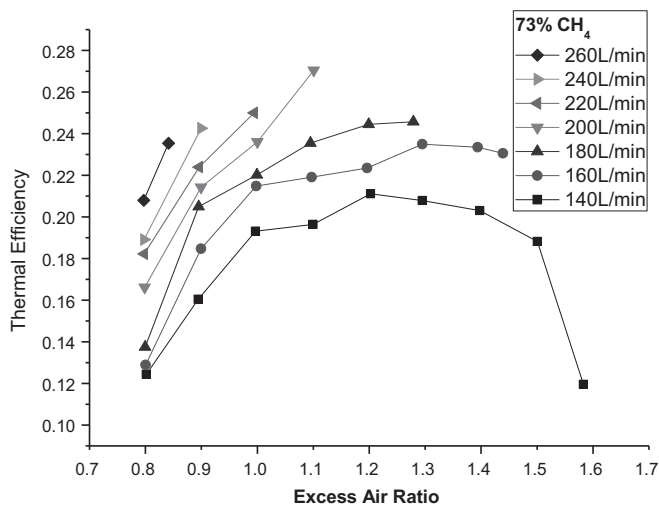

Fig. 4. Thermal efficiency vs. excess air ratio at different biogas supply rates.

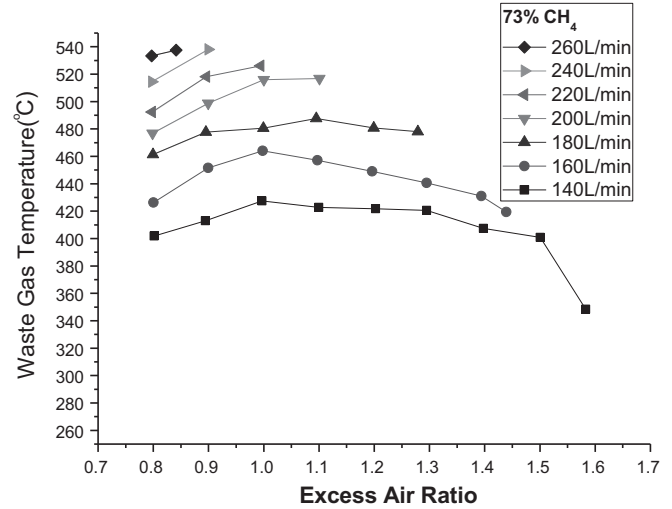

Fig. 5. Waste gas temperature vs. excess air ratio with different biogas supply rates.

$$\dot{m}_{CH_4} = \text{biogas flow rate} \times CH_4\% \times \rho_{CH_4} \quad (5)$$

where  $\rho_{CH_4}$  is the density of methane, which is 0.717 kg/m<sup>3</sup> at STP.

The theoretical percentage of CH<sub>4</sub> consumed and the percentage of CO<sub>2</sub> in the waste gas during the combustion process are calculated as follows:

The balanced reaction is:

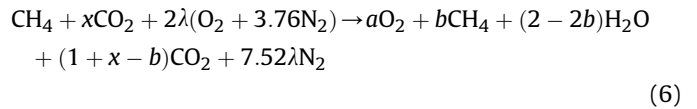

where the NO<sub>x</sub> concentration (in ppm) in waste gas can be neglected,  $x$  is the moles of CO<sub>2</sub> in the biogas, and  $a$  and  $b$  are the moles of O<sub>2</sub> and CH<sub>4</sub> in the waste gas, respectively. The percentage of O<sub>2</sub> in the waste gas can be used to calculate “ $a$ ” as follows:

$$\text{mole fraction (\%)} \text{ of } O_2 = \frac{a}{1 + x + 9.52\lambda} \quad (7)$$

where  $1 + x + 9.52\lambda$  is the total moles of waste gas and “ $b$ ” is obtained from the atom balance as:

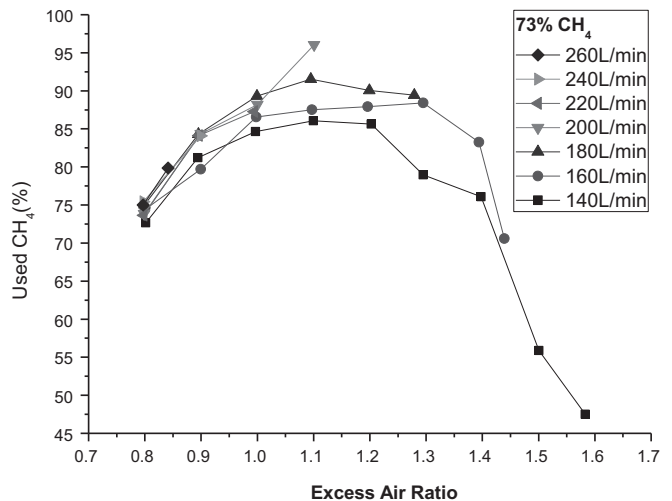

Fig. 6. Estimated CH<sub>4</sub> consumption ratios in combustion vs. excess air ratio with different biogas supply rates.

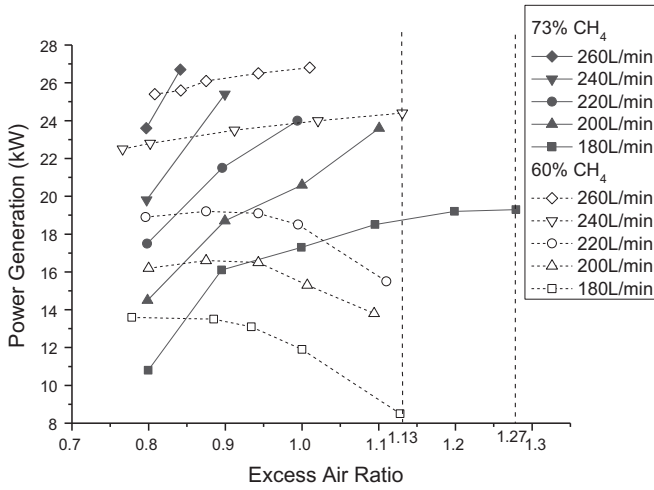

Fig. 7. Power generation with different methane concentrations of biogas.

$$b = 1 - \lambda + \frac{a}{2} \quad (8)$$

The theoretical percentage of CO<sub>2</sub> in the waste gas can be calculated by:

$$\text{Theoretic mole fraction of CO}_2(\%) = \frac{1 + x - b}{1 + x + 9.52\lambda} \quad (9)$$

The theoretical percentage of used CH<sub>4</sub> is defined as:

$$\text{Theoretical percentage of consumed CH}_4(\%) = \frac{(\text{CH}_4)_{\text{in}} - (\text{CH}_4)_{\text{out}}}{(\text{CH}_4)_{\text{in}}} \quad (10)$$

For the effect of methane concentration, the experimental parameters include two methane concentrations of biogas (60% and 73%), the biogas flow rate, and the excess air ratio. The biogas flow rates are set as 140, 160, 180, 200, 220, 240, and 260 L/min. At each fixed biogas flow rate, different excess air ratios are tested, ranging from 0.8 to 1.6. For the effect of intake-gases temperature, the inlet gas (the mixture of biogas and air) is preheated to different temperatures before the gas mixture enters the engine. The biogas flow rates are 140, 160, and 180 L/min, and the excess air ratios

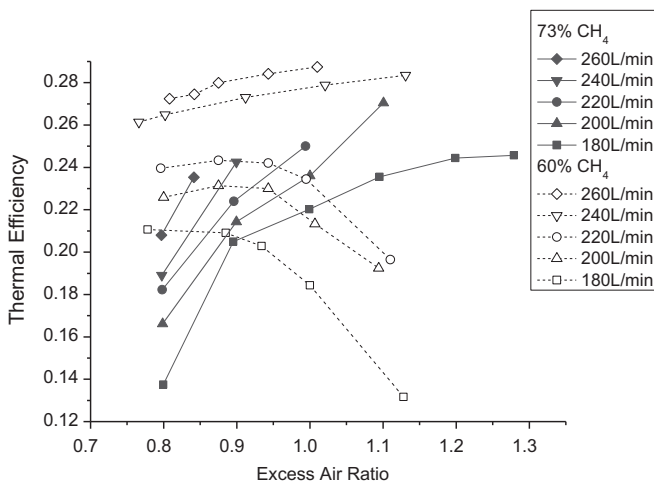

Fig. 8. Thermal efficiency with different methane concentrations of biogas.

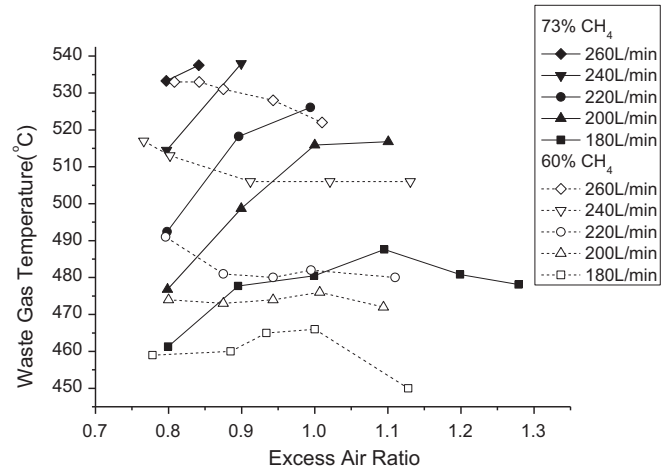

Fig. 9. Waste gas temperature with different methane concentrations of biogas.

range from 0.8 to 1.6. The collected data included the biogas flow rate, air flow rate, power generation, waste-gas temperature, intake-gas temperature, carbon monoxide concentration, oxygen concentration, and carbon dioxide concentration. Before taking any measurements, the engine was run continuously until all the conditions reached a steady state.

### 3. Result and discussion

In this section, the effect of the excess air ratio on the methane consumption ratio is described. In addition, a description is given of the effect of methane concentration and inlet-gas temperature on power generation, waste-gas temperature, intake-gas temperature, carbon monoxide concentration, oxygen concentration, and carbon dioxide concentration.

#### 3.1. Effect of excess air ratio ( $\lambda$ )

The maximum allowable total volume flow rate into the engine is approximately 1800 L/min; therefore, the maximum air supply rate is limited by the flow rate of the supplied biogas. In other

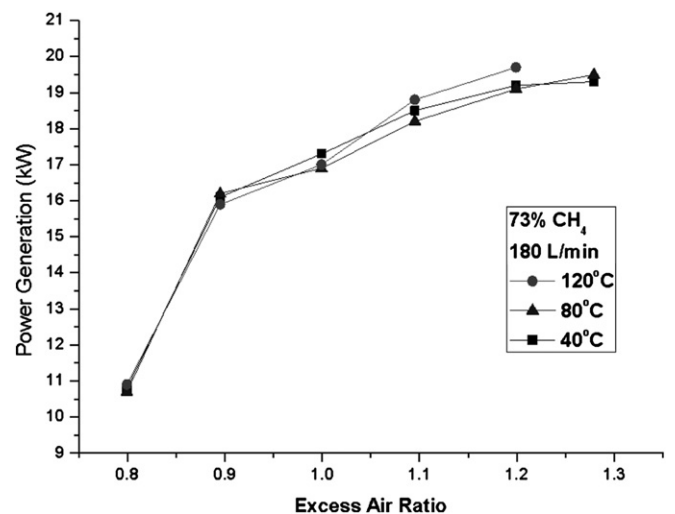

Fig. 10. Power generation of biogas supply rate 180 L/min vs. excess air ratio with different inlet gas temperatures.

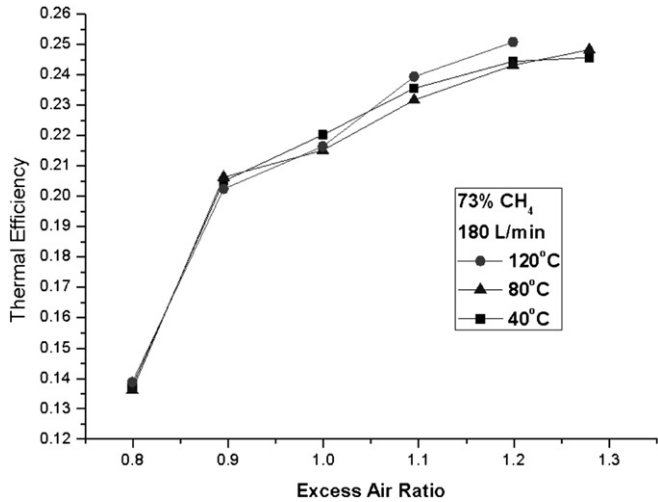

Fig. 11. Thermal efficiency of biogas supply rate 180 L/min vs. excess air ratio with different inlet gas temperatures.

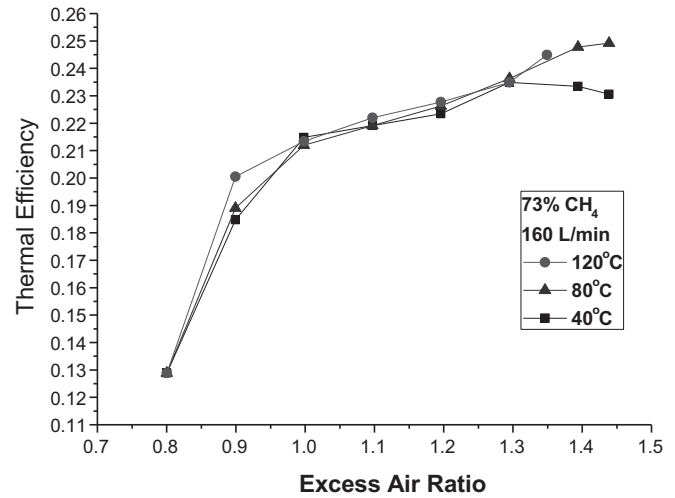

Fig. 13. Thermal efficiency of biogas supply rate 160 L/min vs. excess air ratio with different inlet gas temperatures.

words, the experiments with the higher biogas flow rates were conducted with a narrower range of air-flow supply rates.

Figs. 3 and 4 show the power generation and thermal efficiency, respectively, as a function of the excess air ratio at different biogas supply rates with a 73% methane concentration. The data for a biogas flow rate of 140 L/min suggests that there is a complete flammability domain between the upper and lower limits, which are  $\lambda = 0.8$  and  $\lambda = 1.58$ , respectively. As the biogas flow rate increases, the lower flammability limit ( $\psi$ ) is no longer reached because of the restricted air supply rate mentioned previously. On the other hand, the upper limit can be maintained at a fixed value of  $\lambda = 0.8$ .

For any given excess air ratio, the higher the biogas supply rate, the higher the power generation. When the biogas supply rates are greater than 180 L/min, then for each fixed biogas flow rate, power generation and thermal efficiency increase with an increase in excess air ratio. When the biogas supply rates are less than 180 L/min, the lower the biogas supply rate and the smaller the optimal excess air ratio ( $\lambda$ ) because the total heat energy released from the combustion process is lower at lower biogas supply rates. The

results show that the engine can produce higher power and greater thermal efficiency when higher biogas supply rates with larger excess air ratios are used, but the maximum inlet-gas flow rate of the engine limits the amount of the increase.

Similar to power generation and thermal efficiency, Fig. 5 shows that for a specified excess air ratio, the waste-gas temperature increases as the biogas supply rate is increased. This is because more heat can be released during combustion when the biogas supply rate is increased, therefore leading to a higher waste-gas temperature.

In Fig. 6, the highest CH<sub>4</sub> consumption ratio is 96.03% at a biogas supply rate of 200 L/min with  $\lambda = 1.1$ , which is consistent with the highest thermal efficiency.

### 3.2. Effect of methane concentration

Figs. 7 and 8 show the power generation and thermal efficiency for biogas with a 60% and 73% methane concentration, respectively. In Fig. 7, the power generation for a biogas with 73% CH<sub>4</sub> is higher than that for a biogas with 60% CH<sub>4</sub>, except in the region near

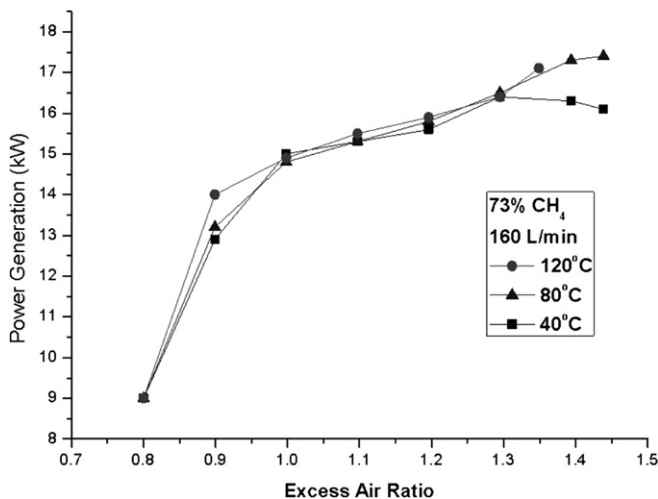

Fig. 12. Power generation of biogas supply rate 160 L/min vs. excess air ratio with different inlet gas temperatures.

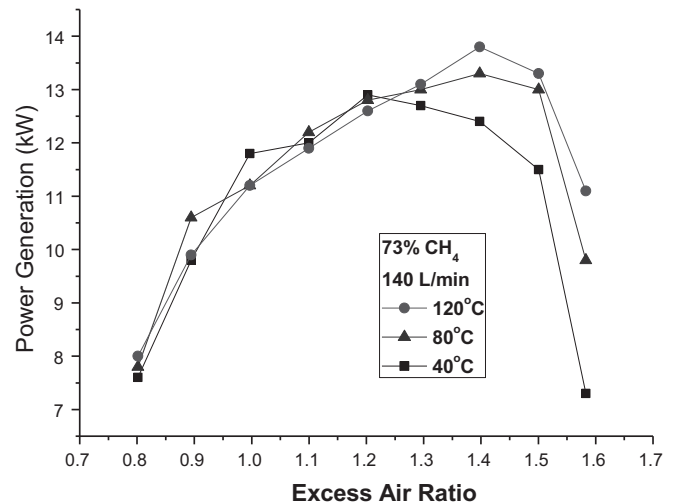

Fig. 14. Power generation of biogas supply rate 140 L/min vs. excess air ratio with different inlet gas temperatures.

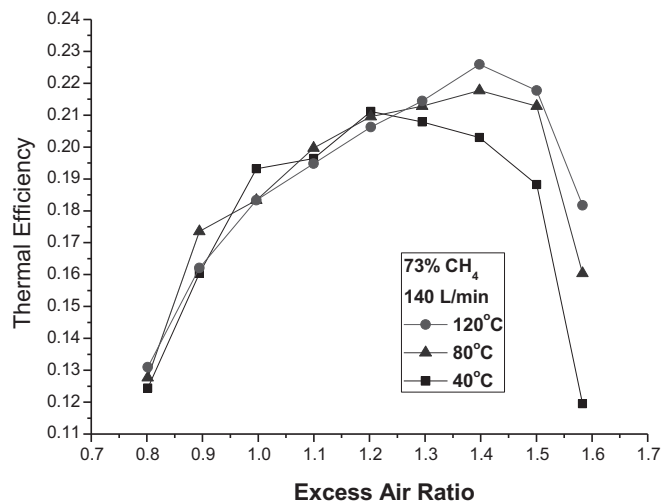

Fig. 15. Thermal efficiency of biogas supply rate 140 L/min vs. excess air ratio with different inlet gas temperatures.

$\lambda < 0.85$ . However, in Fig. 8, the thermal efficiency increases with increasing methane concentration when the excess air ratio is greater than 0.95 (near-stoichiometric condition). In the region where  $\lambda > 0.95$ , the thermal efficiency for 73% CH<sub>4</sub> is greater than the thermal efficiency for 60% CH<sub>4</sub>. This improvement extends the lean misfire limit. For 180 L/min (Figs. 7 and 8), it is clearly shown that the lean misfire limit is widened from 1.13 to 1.27. For the mixture on the relatively rich side ( $\lambda < 0.95$ ), there is no benefit. Moreover, in this region, the thermal efficiencies with 73% CH<sub>4</sub> are much less than those with 60% CH<sub>4</sub>. This is because incomplete combustion is critical in the fuel-rich region [5]. Moreover, when the methane concentration increases or when the excess air ratio decreases, in the region where the mixture becomes richer, the flame velocity is relatively faster when compared to the lean mixture. This means that the spark timing should be delayed to avoid knocking, but because the spark timing is fixed in this experiment, a spark delay could not be accomplished.

Fig. 9 shows that the waste-gas temperature for a biogas with 73% CH<sub>4</sub> is higher than for one with 60% CH<sub>4</sub> because higher heat energy is produced with the higher CH<sub>4</sub> concentration biogas at the same biogas supply rate. To summarize, in the lean region, the rise in methane concentration can increase power generation and thermal efficiency. In the fuel-rich region, the incomplete combustion and improper ignition timing lead to a thermal efficiency that is lower than expected.

### 3.3. Effect of inlet gas temperature

The inlet gases, initially at approximately 40 °C, are mixed in the heat exchanger and then preheated to 80 and 120 °C. Preheating the inlet gases results in an improved biogas and air mixture. As the temperature rises, the collisions between gas molecules increase. The homogeneous mixture of fuel and air can stabilize the combustor temperature during the combustion process; therefore, the engine performance is more stable. However, from Figs. 10 and 11, for the biogas supply rate of 180 L/min, the effect of the inlet gas temperature on power generation and thermal efficiency is not obvious. In Figs. 12–15, for a biogas rate of 140 L/min and 160 L/min,

the effect of the temperature increases when  $\lambda$  is approximately 1.3. From Figs. 3 and 4, the performance of the unheated inlet gas, for a biogas rate of 140 L/min and 160 L/min, begins to decrease at  $\lambda = 1.2$  and  $\lambda = 1.29$ , respectively. Within this region, where the flame velocity is relatively low and the performance starts to decrease, the increased temperature can play a significant role. Outside of this region, the flame velocity is relatively high; therefore, the increased temperature has no effect on the engine performance.

## 4. Conclusions

Based on the results of this study, the following conclusions can be asserted.

1. For a given excess air ratio, the higher the biogas supply rate, the higher the power generation.
2. When the methane concentration rises from 60 to 73%, the trends for power generation and thermal efficiency are modified, and the corresponding lean misfire limit can be widened from  $\lambda = 1.13$  to  $\lambda = 1.27$  for 180 L/min.
3. Power generation for biogas with 73% CH<sub>4</sub> is higher than for biogas with 60% CH<sub>4</sub>, except in the region where  $\lambda < 0.85$ . However, thermal efficiency increases with the increasing methane concentration only in the region of  $\lambda > 0.95$ . There is no benefit for the mixture on the relatively rich side ( $\lambda < 0.95$ ).
4. The effect of increasing the inlet gas temperature on power generation and thermal efficiency is obvious when excess air ratios are relatively high ( $\lambda > 1.3$ ).
5. Although, the authors have not experimental data for other engines, we will have a new project for gas turbine engine.

## Acknowledgements

The authors express grateful appreciation to the National Science Council and the Ministry of Education for their financial support under the project NSC 98-3114-B-009-002.

## References

- [1] Chen Falin, Lu Shyi-Min, Wang Eric, Tseng Kuo-Tung. Renewable energy in Taiwan. *Renewable and Sustainable Energy Reviews* 2010;14:2029–38.
- [2] Rasi S, Veijanen A, Rintala J. Trace compounds of biogas from different biogas production plants. *Energy* 2007;32:1375–80.
- [3] Tsai Wen-Tien, Lin Che-I. Overview analysis of bioenergy from livestock manure management in Taiwan. *Renewable and Sustainable Energy Reviews* 2009;13:2682–8.
- [4] Tippayawong N, Promwungkwa A, Rerkkriangkrai P. Long-term operation of a small biogas/diesel dual-fuel engine for on-farm electricity generation. *Bio-systems Engineering* 2007;98:26–32.
- [5] Porpatham E, Ramesh A, Nagalingam B. Investigation on the effect of concentration of methane in biogas when used as a fuel for a spark ignition engine. *Fuel* 2008;87:1651–9.
- [6] Abd-Allia GH, Soliman HA, Badr OA, Abd-Rabbo MF. Effect of diluents admissions and intake air temperature in exhaust gas recirculation on the emissions of an indirect injection dual engine. *Energy Conversion and Management* 2001;42:1033–45.
- [7] Abdul Semin, Ismail Rahim, Abu Bakar Rosli. Effect of diesel engine converted to sequential port injection compressed natural gas engine on the cylinder pressure v.s. Crank angle in variation engine speeds. *American Journal of Engineering and Applied Sciences* 2009;2(1):154–9.
- [8] Ga-Le Minh Tien Bui Van, Le Bich Tram Truong, Luong Tran Hau. Biogas-gasoline hybrid engine. Da Nang University; 2008.
- [9] Huang Jindang, Crookes RJ. Assessment of simulated biogas as a fuel for the spark ignition engine. *Fuel* 1998;77:1793–801.