



Self-protected ring-star-architecture TDM passive optical network with triple-play management

C.H. Yeh ^{a,*}, C.W. Chow ^b, Y.L. Liu ^a

^a Information and Communications Research Laboratories, Industrial Technology Research Institute (ITRI), Chutung, Hsinchu 31040, Taiwan

^b Department of Photonics and Institute of Electro-Optical Engineering, National Chiao Tung University, Hsinchu 30010, Taiwan

ARTICLE INFO

Article history:

Received 12 January 2010

Received in revised form 14 March 2011

Accepted 14 March 2011

Available online 2 April 2011

Keywords:

Fiber-fault
Self-protection
TDM-PON
CATV

ABSTRACT

A new self-protected apparatus in ring-star-architecture for time division multiplexed passive optical network (TDM-PON) against fiber-fault; together with triple-play management in optical layer is proposed and investigated. Different scenarios of fiber-fault locations are also discussed and analyzed. Besides, the performance of data traffics in both uplink and downlink directions are also measured and studied. Standard CATV video signal distribution to each ONUs is also performed, showing the proposed access network cannot only have self-restored function, but also can manage triple-play services in the optical layer.

© 2011 Elsevier B.V. All rights reserved.

1. Introduction

Recently, due to the development of high speed and high capacity Internet, IP telephony, Video on demand (VoD), IP television (IP-TV), interactive gaming, and video conference etc., the requirement of broadband services is accelerated. Thus, passive optical network (PON) is regarded as the most promising candidate for fiber to the home (FTTH) access network because of its benefits of low cost, long transmission length, high capacity and bandwidth, and multi-service convergence [1]. Hence, the Ethernet PON (EPON) and Gigabit PON (GPON) have already been standardized and they are currently operating at nominal line rates of 1.25 and 2.5 Gb/s, respectively [2,3]. The existing TDM-PON systems can provide triple-play services: data, voice and video, for users with guarantee quality of service (QoS). In the standard triple-play access systems, the downstream signal (1490 nm) and video signal (1550 nm) from the optical line terminal (OLT) are broadcasting to each optical network units (ONUs), and the upstream signal (1310 nm) of each ONU is transmitted to the OLT by TDM framing [2–5]. However, if a fiber-fault occurs between the OLT and ONU, data traffic will be disconnected. Therefore, several protection technologies have been performed and analyzed in PON systems [6–8]. In triple-play system, the downlink (1490 nm) and uplink (1310 nm) are required, however, the video service (1550 nm) is optional. In present systems, if an ONU does not want the video service, the OLT cannot control and manage whether the video service (such as CATV and IP-TV etc.) allows into each ONU according to the Standard [2].

In this study, we propose and demonstrate a self-restored ring-star architecture for TDM-PON system against fiber failure. The new proposed OLT and ONU modules are used in the proposed PON system to achieve self-healing function. Here, we also design a simple control module in each ONU for controlling the video distribution directly in the optical layer. In addition, the performance of the proposed PON architecture has also been discussed.

2. Experiments and results

Fig. 1 shows the proposed ring-star-architecture for TDM-PON system with the fiber-fault protection and video service management function simultaneously. In Fig. 1, the red, blue and green arrow lines represent the downlink, uplink and video signals, respectively. The downlink and video signals couple together by WDM coupler (WC) and are shared to each ONU by a $1 \times N$ splitter (S). In remote node (RN), we use a $2 \times N$ splitter (S) to connect the OLT and ONUs. In the inset of Fig. 1 (ONU structure), we add two 1×1 optical switches (OS_1 and OS_2) and a 2×2 optical coupler (CP) on each ONU to achieve self-restoration and video service management. Each ONU in the proposed PON system is interconnection in the ring architecture and the OS_1 is used to connect to the protecting fiber (dash line). In the inset of Fig. 1 (OLT structure), we add a 1×2 optical switch (OS_3) in the OLT for selecting the transmission path between the working fiber (solid line) and the protecting fiber (dash line). Initially, the OS_3 is switched to connect the working fiber for transmitting downlink and video signals to each ONU under normal status and the OS_1 in the ONU is at “off state” to block the uplink signal transmitting into the protecting fiber, as illustrated in Fig. 1.

Generally, there could be two fiber-faults: in the feeder fiber and the distributed fibers in the PON. For the proposed PON architecture, if a

* Corresponding author at: Bldg. 14, 195, Sec. 4, Chung-Hsing Rd., Chutung, Hsinchu 31040, Taiwan.

E-mail addresses: depew@itri.org.tw, yeh1974@gmail.com (C.H. Yeh).

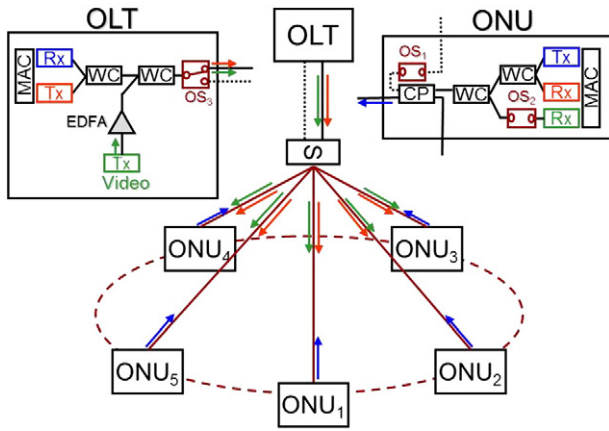

Fig. 1. Proposed self-protection ring-star-architecture TDM-PON system without fiber-fault occurring. S: 1 × N splitter; OS: optical switch; WC: WDM coupler; Tx: transmitter; Rx: receiver; MAC: medium access control; EDFA: erbium-doped fiber amplifier.

fiber failure occurs in feeder fiber (between OLT and RN), as seen in Fig. 2, the entire data traffic is blocked. This means the OLT cannot broadcast downlink and video signals to each ONU and cannot receive uplink signals from all ONUs. Then, in our proposed network architecture, the MAC of OLT will switch the OS₃ immediately to connect to the protecting feeder fiber for reconnecting for the entire data traffic. At this time, the protecting fiber can be regarded as a working fiber. While the fault is restored, it would become to the protecting fiber.

Next, while an occurrence of fault in the distributed fiber (between RN and ONU₁), as shown in Fig. 3, the ONU₁ could not connect to the OLT. At this moment, the OS₁ of ONU₁ would be turned on to connect to the protecting fiber. The uplink data will pass through the CP of ONU₂ to reconnect to the OLT. This means that each ONU can reconnect to the OLT by transmitting data through the neighbor ONU to achieve self-restoration against fiber-fault, as illustrated in Fig. 3. Besides, while two fiber-faults occur between RN and ONU₁ and RN and ONU₂ simultaneously, the ONU₁ and ONU₂ cannot connect the OLT. Thus, according to the proposed protected mechanism, the OS₁ of ONU₁ and ONU₂ would be turned on to connect to the protecting fiber with the adjacent ONU simultaneously, as illustrated in Fig. 4. It means that the ONU₁ and ONU₂ could reconnect the data traffic transmitting through the ONU₃. Based on the same principle, if several distributed fibers are cut, the affected ONUs can shared the same distributed fiber with the surviving ONU.

Moreover, while the fault faults occur both at the feeder and distributed fibers, each ONU cannot receive the downlink and video

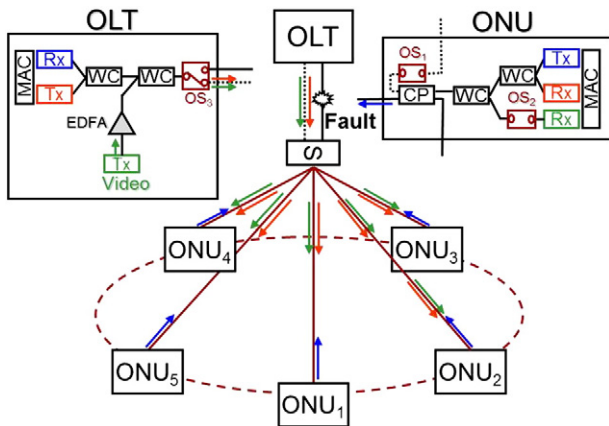

Fig. 2. Proposed self-protected access network with an occurrence of fiber-fault between OLT and RN.

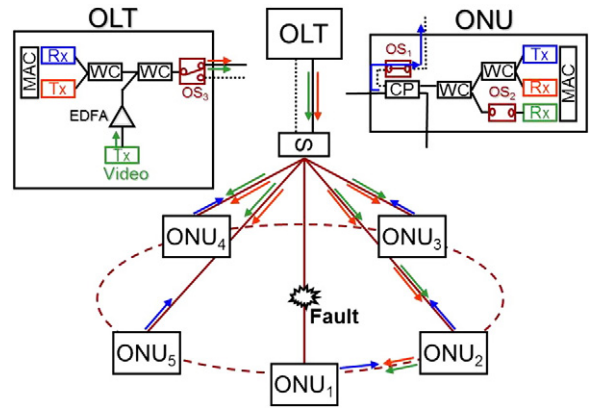

Fig. 3. Proposed self-protected access network with an occurrence of fiber-fault between RN and ONU₁.

signals from OLT. At this moment, OS₃ could switch to connect with protecting fiber, and the OS₁ of ONU could be turned on to connect to the protecting fiber. It is worth to mention that the operating of each ONUs will not be affected, since the downlink and video signals are still in broadcast mode and the uplink signal is still in TDM mode [2].

To realize the performance of the proposed self-protection TDM-PON system, an experiment is executed. The experimental setup is shown in Fig. 1 with four ONUs. The transmission length between OLT and each ONUs is 20 km, and the separation between two adjacent ONUs is 2 km. The 1490 and 1310 nm wavelengths are the downlink and uplink signals, using 2.5 and 1.25 Gb/s direct modulated signals respectively. They are modulated by non-return-to-zero (NRZ) data, with a pseudo random binary sequence (PRBS) pattern length of $2^{31}-1$. In this measurement, the output powers of the downlink (Distributed Feedback laser) and the uplink (Fabry–Perot laser) signals are 2.2 and 2.4 dBm. For the case of 16 ONUs, in regard to the maximum power budget of the proposed PON scheme, the downlink and uplink signals would transmit through two WCs (~1.8 dB), two OSs (~2 dB), a 1 × 16 splitter (~12 dB), a 1 × 2 CP (~3 dB), and 22 km fiber (~4.4 dB), respectively. Here, about <23 dB loss budget can be produced in the system. Fig. 5 shows the bit error rate (BER) curves versus different received power under back-to-back (B2B), without and with protecting operation in Fig. 5. Negligible power penalties are observed at BER of 10^{-9} without and with the fiber protection. Besides, we can use the DFB-LD of ~5.5 dBm output power to solve the insufficient power budget in the proposed PON system, when the 1 × 16 splitter is replaced by 1 × 32 splitter. The inset of Fig. 5 shows the restorable time of the proposed protection PON system is within 10 ms due to the switching limitation of optical switch. In the proposed PON

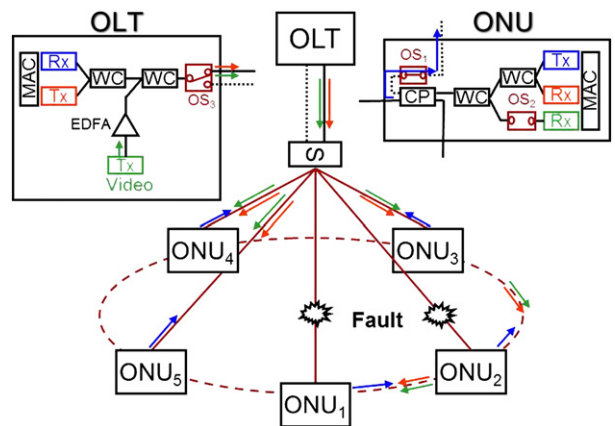

Fig. 4. Proposed self-protected access network with the occurrences of two fiber-faults between RN and ONU₁ and RN and ONU₂.

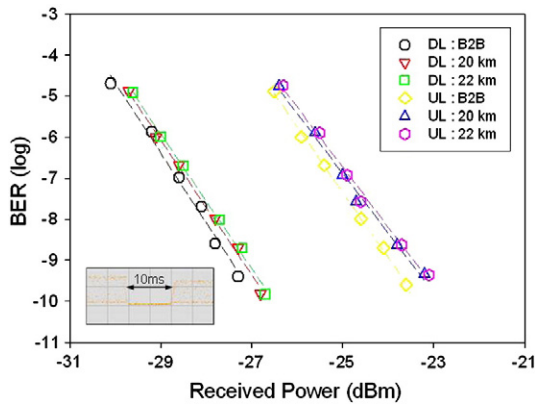

Fig. 5. BER curves versus different received optical power for the 2.5 Gb/s downlink and 1.25 Gb/s uplink traffic under the B2B, without and with protection status, respectively. Insert is the switching time of optical switch.

system, the switching time depends on the optical switch (OS), which are used in the OLT and ONU. If one wants to reduce the switching time, we can employ the faster commercial optical switch for signal routing.

We use the standard CATV video signal broadcasting to each ONUs in the experiment. Actually, there are no any standards to determine whether the video signal can be allowed into each ONU. Thus, in order to manage the video service distribution to a large number of individual user, OS_2 is added in each ONU to control the video signal distribution in optical layer, as shown in Fig. 1. Initially, the OS_2 of all ONUs are in the “on state” allowing to receive the video signal. If an ONU does not want the video service, the OLT only give a message to MAC of ONU for turning off the OS_2 to stop the service. The proposed management of video service only requires the control of the OS_2 . It can reduce the loading of MAC layer management.

To confirm the proposed technology, the CATV signal having the operating bandwidth from 50 to 750 MHz with 6 MHz channel spacing is used in the proposed access network. Fig. 6(a) and (b) shows the output RF spectra of the CATV signal from 50 to 750 MHz after passing through 20 km fiber transmission when the OS_2 is turned on and off, respectively. As also illustrated in Fig. 6(a), between 103.25 and 163.25 MHz, there is a gap-band that are reserved for other applications

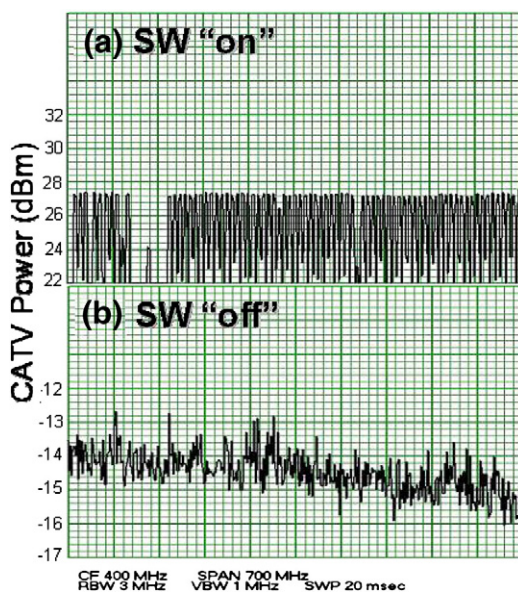

Fig. 6. Output RF spectra of CATV signal from 50 to 750 MHz with 6 MHz channel spacing after through 20 km fiber transmission when the OS_2 is turned (a) on and (b) off, respectively.

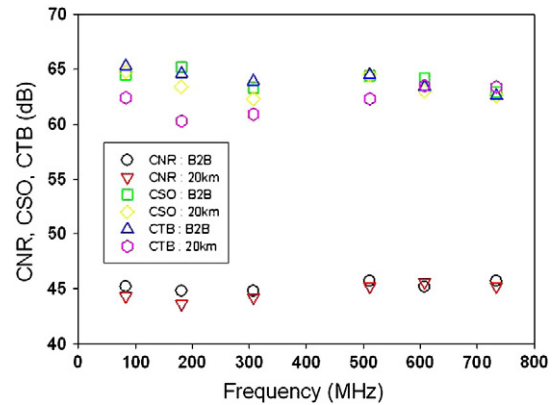

Fig. 7. Measured values of CNR, CSO and CTB under different NTSC channels from 83.25 MHz to 733.25 MHz.

according to the CATV standard. When the OS_2 is in “off state”, the CATV channels could be isolated, as shown in Fig. 6(b).

When multiple CATV channels are transmitted through a nonlinear device, such as an optical amplifier, the composite second order (CSO) and composite triple beat (CTB) would be generated to effect and distort the video signal [9–11]. In addition, in this experiment we also measure the values of CNR, CSO and CTB under different NTSC channels from 83.25 MHz to 733.25 MHz in our proposed access network, as illustrated in Fig. 7, when the CATV wavelength is 1550 nm at 7.6 dBm input power. Fig. 7 presents the maximum distorted values of CNR, CSO and CTB are 1.2, 1.8 and 4.3 dB at 181.24 MHz frequency band, respectively, after transmitting through our proposed PON system.

3. Conclusion

We proposed and demonstrated a novel new self-restored ring-star-architecture for TDM-PON with triple-play management in optical layer. Different scenarios of fiber-fault locations, e.g. in feeder and/or distributed fibers were analyzed. BER performance of data traffics in both uplink and downlink directions in the working and protecting modes were measured and studied. Standard CATV video signal distribution to each ONUs was also performed, showing the proposed network cannot only have self-restored function, but also can manage triple-play services in the optical layer.

References

- [1] P.W. Shumate, J. Lightwave Technol. 26 (2008) 1093.
- [2] Gigabit-Capable Passive Optical Network (GPON): General Characteristics, ITU-T Recommendation G. 984.1, 2003.
- [3] Ethernet in the First Mile Task Force, IEEE 802.3ah, Draft 3.0b, 2004.
- [4] K.M. Choi, S.M. Lee, M.H. Kim, C.H. Lee, IEEE Photon. Technol. Lett. 19 (2007) 647.
- [5] K.M. Choi, J.H. Moon, J.H. Lee, C.H. Lee, IEEE Photon. Technol. Lett. 20 (2008) 312.
- [6] C.H. Yeh, S. Chi, IEEE Photon. Technol. Lett. 19 (2007) 1139.
- [7] T.J. Chan, C.K. Chan, L.K. Chen, F. Tong, IEEE Photon. Technol. Lett. 15 (2003) 1160.
- [8] X. Sun, Z. Wang, C.K. Chan, L.K. Chen, OFC, 2005., paper JWA53.
- [9] S.P. Singh, N. Singh, Prog. Electromagnetics Res. PIER 73 (2007) 249.
- [10] H. Gebretsadiq, H.T. Foulk, N.C. Frateschi, W.J. Choi, S.V. Robertson, A.E. Bond, Electron. Lett 40 (2004) 1016.
- [11] C.C. Lee, S. Chi, IEEE Photon. Technol. Lett. 12 (2000) 341.