

A 3D photographic capsule endoscope system with full field of view

Mang Ou-Yang¹, Wei-De Jeng^{*2}, Chien-Cheng Lai², Yi-Chinn Kung¹ and Kuan-Heng Tao¹

¹Department of electrical engineering, National Chiao Tung university Hsinchu City, Taiwan

²Department of electrical and control engineering, National Chiao Tung university Hsinchu City, Taiwan

*Corresponding author: jwd.ece99g@nctu.edu.tw

ABSTRACT

Current capsule endoscope uses one camera to capture the surface image in the intestine. It can only observe the abnormal point, but cannot know the exact information of this abnormal point. Using two cameras can generate 3D images, but the visual plane changes while capsule endoscope rotates. It causes that two cameras can't capture the images information completely. To solve this question, this research provides a new kind of capsule endoscope to capture 3D images, which is "A 3D photographic capsule endoscope system". The system uses three cameras to capture images in real time. The advantage is increasing the viewing range up to 2.99 times respect to the two camera system. The system can accompany 3D monitor provides the exact information of symptom points, helping doctors diagnose the disease.

1. INTRODUCTION

Due to the busy work and high pressure of life, people almost have no time to eat, this increase the case of digestive disease. Therefore, many medical research teams develop the technical of endoscopy. In the past, the endoscopy and gastroscopy are the most popular and reliable instrument to exam the digestive disease. These years, the swallowable capsule endoscope was developed, hence, improving the endoscopy scope to another level that can exam the digestive disease significantly [1]. So far, the research organization of capsule endoscope includes Given image, Olympus, RF system and China [2-6]. However, the kind of capsule endoscope can only capture the front images, it can be called "front imaging capsule endoscope (FICE)", as shown in Fig. 1. Unfortunately, the FICE exists many disadvantages, the wrinkle in the intestine will hide the important information and causes a dead space, and the doctors will loss this tissue. The other disadvantage is FICE only has one lens, the images only have 2D information, and it is too difficult to get the real geometrical data, for example the tissue size. According to these two disadvantages, this work presents a new kind of capsule endoscope, which is "A 3D photographic capsule endoscope system". The technical core uses three lenses to generate 3D visual and increase the viewing range, it is due to three lenses can build three visual plane, and then get three different direction geometrical information. Hence, it's also called "A full field of view of 3D photographic capsule endoscope system", the concept of this system is shown in Fig. 2 and Fig. 3.

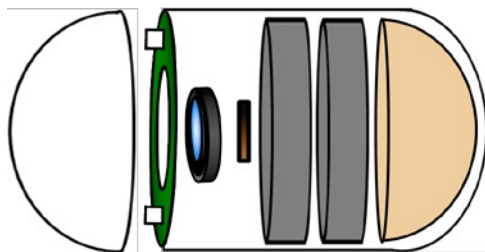

Figure 1. FICE system.

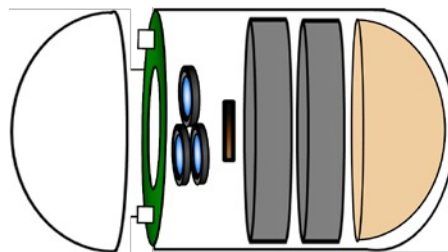

Fig. 2. 3D capsule endoscope.

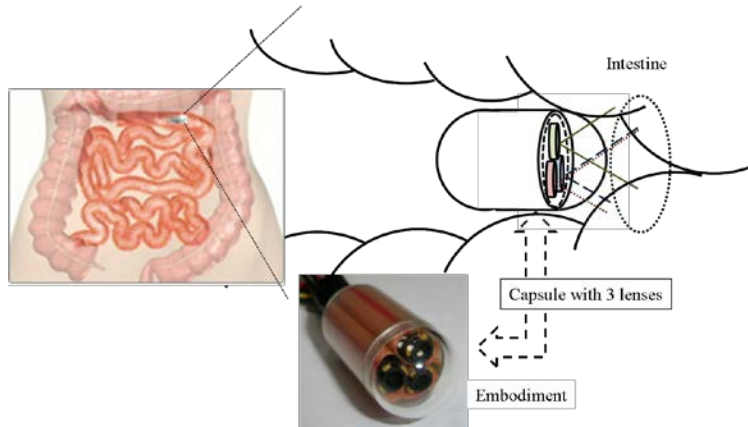

Fig. 3. The application of 3D capsule endoscope

2. METHODOLOGIES

This paper's main technology is using three lenses to produce three images, each of them has its own different visual plane which can produce 3D image information. In general, the 3D imaging method can be created by two lenses. However, two lenses only have a visual plane, this means the 3D images can be produced only when the observer's visual plane is parallel to the system's visual plane. The 3D capsule endoscope uses three lenses to produce more visual plane in this system, this motivation is because the capsule endoscope moves in the intestines may rotate, is the 3D capsule endoscope has only two lenses, which means only one visual plane, and this plane will also rotate at any times when the capsule moving in the intestines. This causes the 3D images can produced in a limited region, in order to improve this issue, this 3D capsule endoscope utilities three lenses to produce three visual planes, hence, this system can get more field of view to produce 3D images. As shown in Fig. 4, images from lenses A, B and C can combine to each other such as AB, AC and BC, therefore the system can produce 3D full visual plane image.

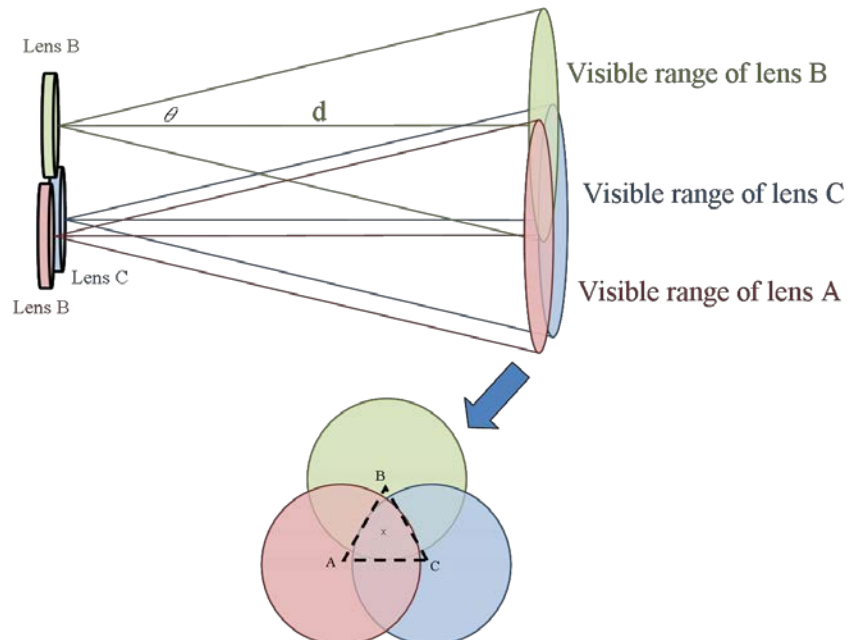

Figure 4. Three lenses produce three visual planes.

All lenses view angle in the system is 60 degree and the lens focus range is d equals 4 cm, the visible range be can defined by the geometric relations as shown in Fig.5, the results is shown in Eq. (1). The φ is the angle $\angle bBA$, a is the

radius of circle A, b is the radius of circle B, and a equals b , d is object distance, θ is view angle of lens, x and y is half length of the diagonal.

$$3D \text{ visual range} = \frac{2\phi}{360^\circ} \pi b^2 - xy = \frac{\cos^{-1}(\frac{x}{d \tan \theta})}{180^\circ} \pi (d \tan \theta)^2 - xd \tan \theta \sin[\cos^{-1}(\frac{x}{d \tan \theta})] \quad (1)$$

The interaction of two images can be calculated through Eq. (1) and the result is 7.19 cm². While using three lenses, it is capable to get 17.91 cm² visible areas from the interaction of two lenses and 3.595 cm² visible areas from the interaction of three lenses. It is more precise for the 3D model which was constructed by three lenses' interactive information than two's. 3D image constructed by 3 lenses has area of 21.505 cm² and it is 2.99 times respect to two lenses, therefore, this system can construct a large range of visual plane. Hence, it is called "A full field of view of 3D photographic capsule endoscope system".

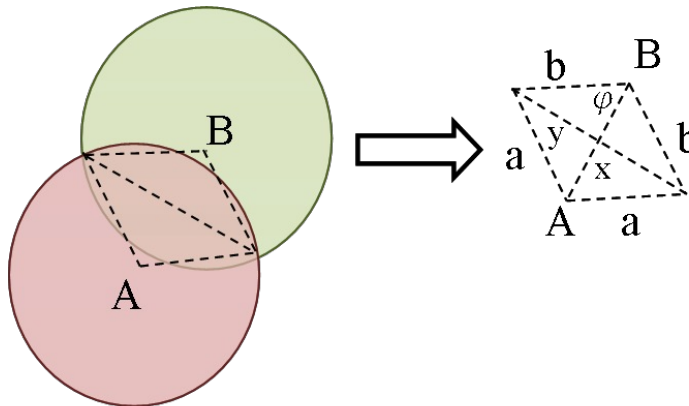

Figure 5. The 3D visible range between two lenses.

There is another advantage in 3D capsule endoscope, which is the size of object can be computed by the three images. As shown in Fig. 6, the object height is H for lens 1, the object height is $H+a$, a is the distance between the two lenses, L is the object distance, q is the image distance, I and I' are the image height for the two lenses respectively. From the three similar triangle, the object height H and object distance L can be determined as Eq. (2). Therefore, the 3D capsule endoscope system can estimate the size of object, it's a very important issue for the doctor to diagnosis the patients' symptom.

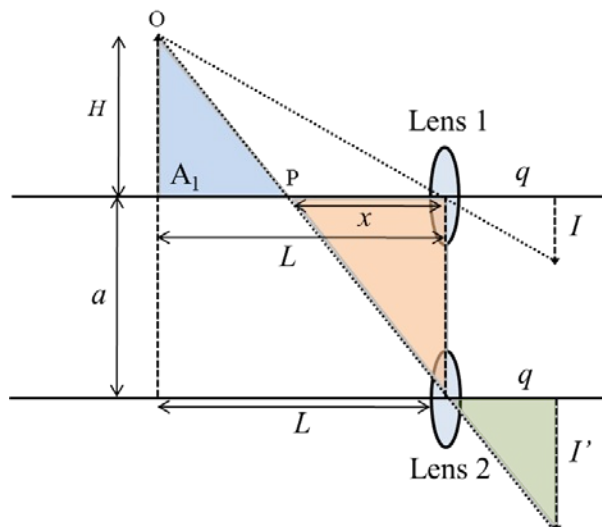

Fig. 6. The object information can be computed by the geometry concept.

$$\begin{cases} H = \frac{aI}{I' - I} \\ L = \frac{aq}{I' - I} \end{cases} \quad (2)$$

This system utilize 3D image with three lenses can get more complete image data with respect to two lenses system. The Tab. 1 shows the system specification of 3D capsule endoscope. The Fig. 7 shows the 3D capsule endoscope diagram and embodiment. The working diagram of the signal transportation is shown in Fig. 8. Firstly, the object information was captured by three lenses, then transforming it to electrical signal such likes CMOS, and this signal can be transported to work station by wireless system like radio frequency transformer or by wired system. The most important role is the power system, it provides the power to all the electrical elements.

Tab. 1 3D capsule endoscope specification

TV System	NTSC
Visible range	3 ~ 5 cm
View angle	60°
Focal length	1 mm
Capsule endoscope diameter	11 mm
Pixel Size	3 μm

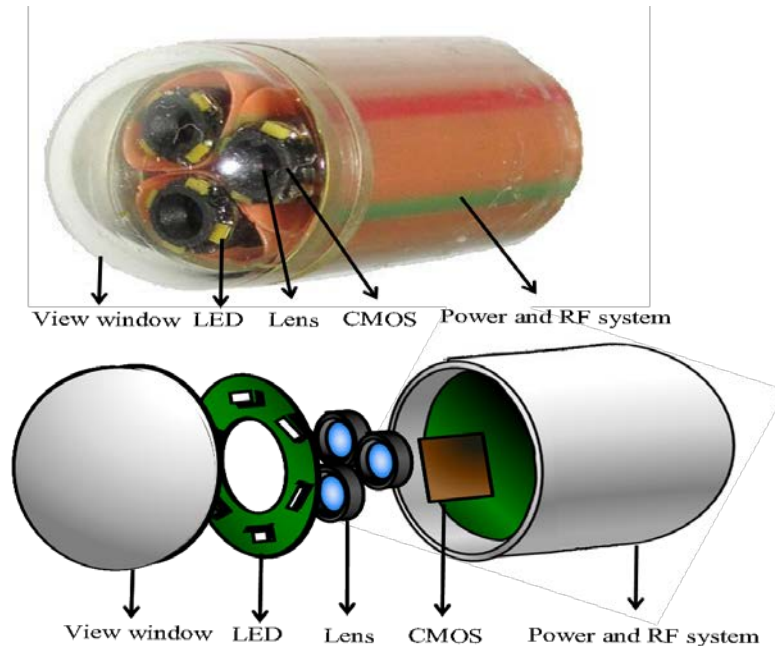

Figure 7. 3D capsule endoscope embodiment (top) and diagram (bottom)

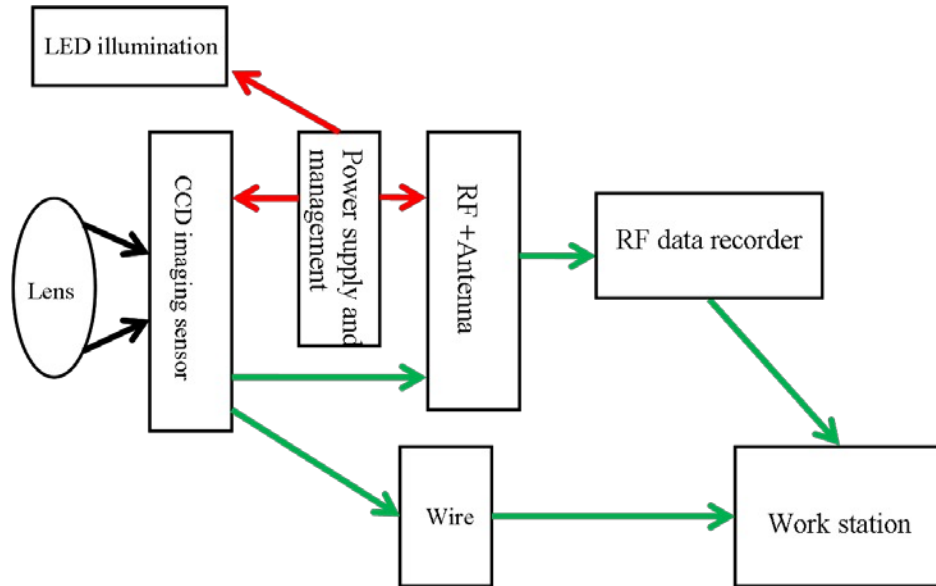

Figure 8. Working diagram

3. EXPERIMENT

The experimental environment includes digital synchronizer VG411 send the images to the 3D display in the same time. In order to build a mimic object like intestine, the phantom was used to capture the images, this phantom was made by the company NASCO Life Form [7]. The Fig. 9 shows the results of this experiment, the object is some part of tissue in the phantom. There are three difference images were captured by the three lenses, every images between each other has some disparity, this is due to the difference view points cause the image difference. Finally, these images can be sent to the 3D display to build the 3D visual images.

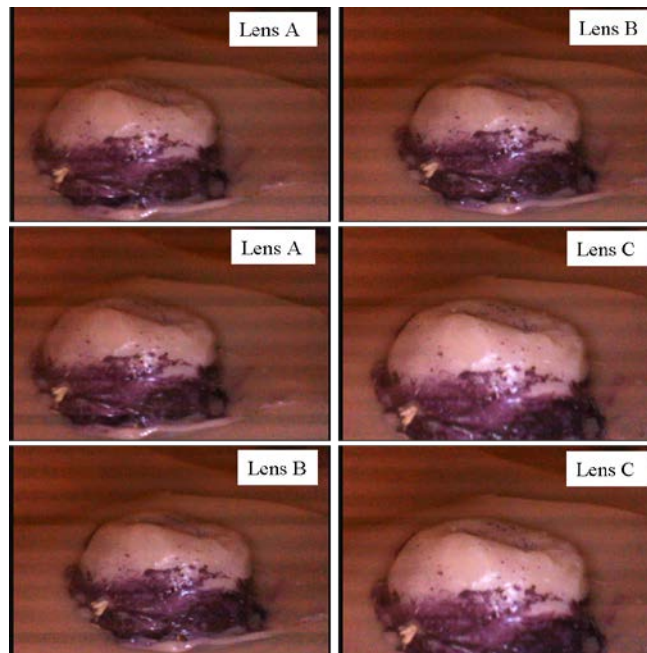

Figure 9. The disparity of each images.

4. CONCLUSIONS AND DISCUSSIONS

This work firstly presents a new kind of 3D capsule endoscope to solve the disadvantage of FICE, which is dead space problem and difficult to determine the size of tissue. Secondly, the viewing range was calculated to compare the visible range between two lenses and three lenses system, and the result shows the three lenses system has the benefit with large viewing range. Finally, experimental results were present, the 3D capsule endoscope indeed captures three images, and each images exists the disparity. This novel technology of capsule endoscope scope will be an important role in Minimally Invasive Surgery. The Surgery is always associated with endoscopy, however, the endoscopy only has 2D image information, it is difficult to know the tissues' depth, width and size, and it will cause high surgical risk. If the endoscopy can replaced by a 3D endoscopy, however, the technical present in this work, it can decrease the surgical risk.

5. ACKNOWLEDGEMENT

This paper was particularly supported by the Aim for the Top University Program of the National Chiao Tung University, the Ministry of Education of Taiwan (Contract No. HCH102-39), the National Science Council of Taiwan (Contract No. NSC 101-2220-E-009-032, 101-2218-E-039-001), Delta Electronics Incorporation (Contract No. NCU-DEL-102-A-02 and 102908-2) and Industrial Technology Research Institute (Contract No. 10161-K08). The authors also want to thank them for providing experimental assistance and related information.

6. REFERENCES

- [1] M. Ou-Yang and W. D. Jeng, "Design and analysis of radial imaging capsule endoscope (RICE) system," *Opt. Express*, 19 (5), 4369-4383 (2011).
- [2] Given imaging, M2A Given® Diagnostic System.<http://www.givenimaging.com/>.
- [3] G. D. Meron, "The development of the swallowable video capsule (M2A)," *Gastrointest. Endosc.* 52(6), 817-819 (2000).
- [4] A. Uehara, and K. Hoshina, "Capsule endoscope NORIKA system," *Minim. Invasive Ther. Allied Technol.* 12(5), 227-234 (2003).
- [5] T. Nakamura, and A. Terano, "Capsule endoscopy: past, present, and future," *J. Gastroenterol.* 43(2), 93-99 (2008).
- [6] H.H Hopkins, N.S. Kapany, "A Flexible Fiberscope using Static Scanning," *Nature.* 173, pp. 39-41, (1954).
- [7] NASCO Life Form, LF1084U, <http://www.nist.gov/index.html>.