



Laser-unzipped carbon nanotube based glucose sensor for separated structure of enzyme modified field effect transistor



Wan-Lin Tsai*, Yun-Shan Chien, Po-Yu Yang, I-Che Lee,
Kuang-Yu Wang, Huang-Chung Cheng

Department of Electronics Engineering and Institute of Electronics, National Chiao Tung University, 1001 University Road, Hsinchu 300, Taiwan

ARTICLE INFO

Article history:

Received 22 May 2013
Received in revised form
10 September 2013
Accepted 24 September 2013
Available online 3 October 2013

Keywords:

Carbon nanotube thin film
Glucose sensor
Separated enzyme modified field effect
transistor

ABSTRACT

A glucose sensing film composed of unzipped multiwalled carbon nanotubes (MWCNTs) via continuous-wave laser irradiation is investigated. Some structural defects decorate on MWCNTs after an acid treatment, and the MWCNTs are unzipped into sheet-shaped layers initiated from these defects after the laser irradiation. The laser-irradiated carbon nanotube thin films (CNTFs) possess higher conductance owing to larger contact area, and the side edges of unzipped CNTs could act as sensing sites for hydrogen ions. Thus the laser-irradiated CNTF as a glucose sensing film could achieve a higher sensitivity of $0.302 \text{ mV}(\text{mg/dl})^{-1}$, equal to $7.55 \text{ mV}(\text{mg/dl})^{-1}$ per centimeter square, and a larger linearity of 0.9947 than the as-sprayed one. Moreover, the fully low-temperature processes of this work also reveal the potentials for flexible and disposable biosensors.

© 2013 Published by Elsevier B.V.

1. Introduction

Clinical diagnostics has shown great eagerness for reliable and fast determination of glucose because the blood glucose level is an important clinical test in the diagnosis of diabetes mellitus. Since the first introduction of enzyme modified field-effect transistor (EnFET) sensor proposed by Caras and Janata in 1980 [1], one has been able to fabricate highly sensitive and selective enzyme-based biosensors by the incorporation of enzyme with a transducer. In recent years, an alternative structure of separated EnFET has been introduced with lower cost, simpler to package, more insensitive to environment, and better long-term stability [2]. The glucose-sensing mechanisms of EnFET and separated EnFET are the same, and the glucose detection could be described as [3]

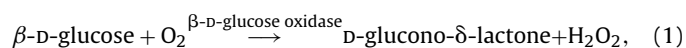

The sensing mechanism is based on detecting the variation of hydrogen ions generating from the reaction of $\beta\text{-D-glucose}$ and glucose oxidase (GOD). Therefore, sufficient sensing sites for the

detection of hydrogen ions and immediate transmission of signal play important roles in the biosensor design.

Recently, carbon nanotube (CNT) has been regarded as one of promising glucose sensing materials since its' high surface-to-volume ratio, excellent electron-transfer rate, outstanding mechanical strength, and nontoxicity [4–6]. By an acid-treated step, the sidewalls of CNTs bond with oxygen-containing functional groups [7,8], making the CNTs hydrophilic to dissolve homogeneously in most solvents, and the CNTs can be deposited onto substrates uniformly to form a carbon nanotube thin film (CNTF). However, these oxygen-containing groups on CNTs are insufficient to take accurate response to the variation of H^+ ions [9]. Furthermore, carriers in the length-limited CNTs need to cross a lot of junctions from one CNT to another [10], and then the CNTFs generally attain a resistance too high to meet the requirements in practical uses nowadays. In this work, continuous-wave laser is applied to achieve the high-performance CNTFs, with higher conductance and more sensing sites, as a glucose sensing film of separated EnFET sensor. The laser-irradiation effects on the CNTs are discussed and a mechanism is also proposed.

2. Experimental

2.1. Materials

The multi-walled carbon nanotubes (MWCNTs) were synthesized by a thermal chemical vapor deposition system as mentioned

* Corresponding author. Tel.: +886 35738343.
E-mail address: nctuwtsai@gmail.com (W.-L. Tsai).

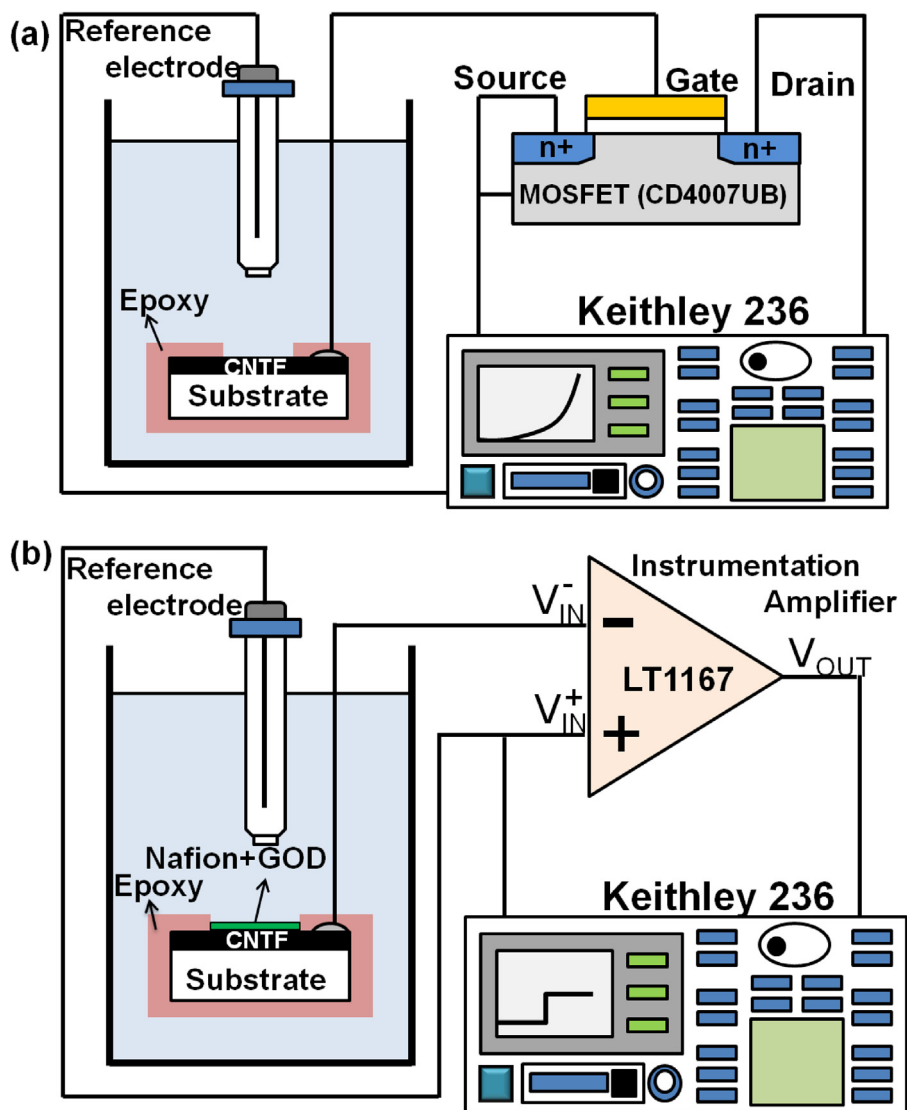

Fig. 1. (a) Schematic diagram of the measurement system for the pH response of extended-gate field-effect transistors (EGFETs). (b) Schematic diagram of the V - t measurement system for the separated EnFET.

in our previous work [11]. Both potassium phosphate monobasic (KH_2PO_4) and potassium phosphate dibasic (K_2HPO_4) were purchased from Katayama Chemical Co., Ltd. (Japan). KH_2PO_4 and K_2HPO_4 were mixed in deionized water to obtain pH = 7.4 of 0.1 M phosphate buffer saline (PBS) solution. Glucose oxidase (GOD, specific for β -D-glucose, 100,000–250,000 units/g solid, from *Aspergillus niger*), glucose powder ($\text{C}_6\text{H}_{12}\text{O}_6$, β -D-glucose, reagent grade), and Nafion (5 wt%) were obtained by Sigma Chemical Company (USA).

2.2. Preparation of separated EnFET

The as-grown CNTs were suspended in a mixture of concentrated H_2SO_4 (95%), HNO_3 (70%), and deionized water. The derived acid-treated MWCNTs were dissolved in a mixture of ethanol and ethylene glycol, and then ultrasonicated for 5 h. After centrifugalizing, a homogeneous MWCNT solution with approximate 0.5 mg/ml concentration of CNTs was sprayed onto a quartz substrate to form a CNTF, and then the CNTF was placed into a chamber pumped down to 2×10^{-2} Torr. Subsequently, the Nd:YAG laser irradiation (wavelength = 532 nm) was executed under the laser power of 4 W and the scan speed of 5 mm/s. Finally, both as-sprayed CNTF and

laser-irradiated one with a sensing window defined as $2 \text{ mm} \times 2 \text{ mm}$ were bonded to the metal wires with silver paste, packaged with epoxy resin, and baked at 120°C for 30 min to form sensing heads.

For the glucose oxidase (GOD) immobilized process, a GOD solution was prepared by mixing 6 mg GOD and 10 ml PBS solution. The Nafion solution was then adopted to immobilize the enzyme and mixed with the GOD solution. Finally, the $3 \mu\text{l}$ enzyme mixed solution was dropped on the surface of sensing head and stored at 4°C for 12 h. The different concentrations of the glucose solutions were controlled as 60, 120, 180, 240, 300, and 360 mg/dl, respectively.

2.3. Measurement

Before immobilizing the GOD, the CNTF and a reference electrode (Ag/AgCl) are immersed into buffer solutions with different pH values and measured the transfer characteristics ($I_{\text{DS}}-V_{\text{REF}}$) for the pH response of extended-gate field-effect transistors (EGFETs), as shown in Fig. 1(a). A Keithley 236 semiconductor parameter analyzer was utilized to measure the $I_{\text{DS}}-V_{\text{REF}}$ characteristics of the pH-EGFETs, connected to the gate of commercial standard MOSFET device (CD4007UB), in pH = 1, 3, 5, 7, 9, 11, and 13 buffer solutions.

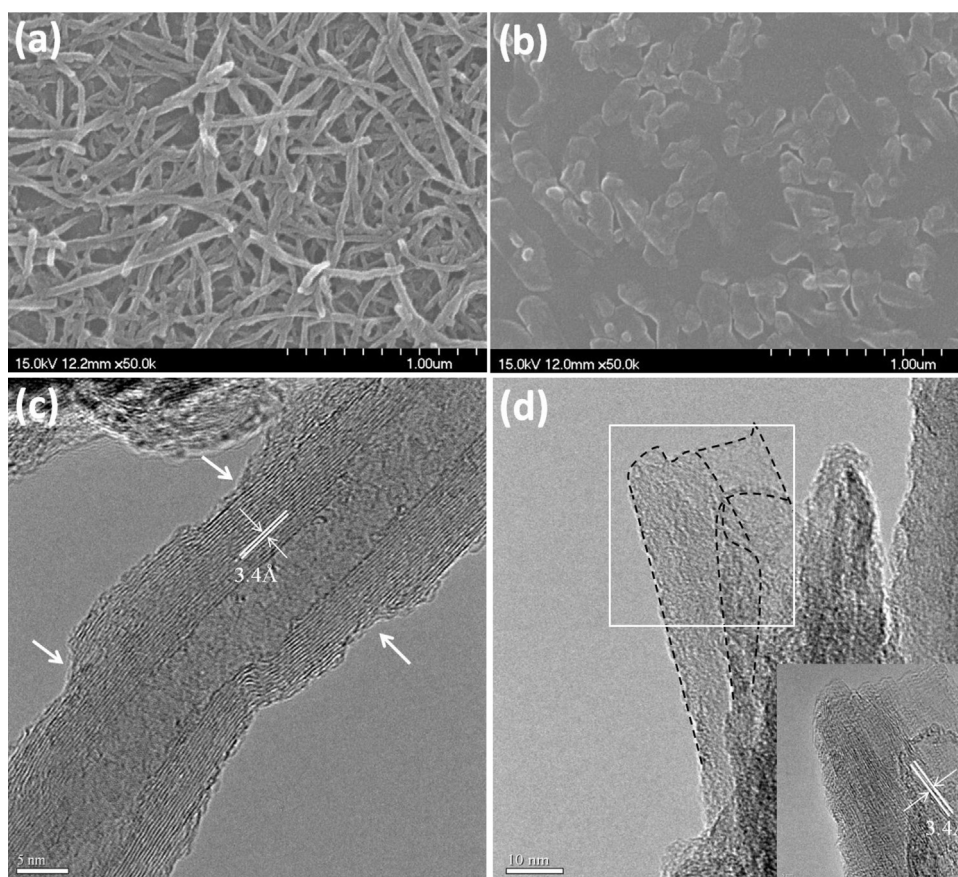

Fig. 2. HR-SEM pictures of (a) as-sprayed and (b) laser-irradiated CNTFs. (c) The TEM picture for an as-sprayed CNT with etched sidewalls indicated by arrows, and the lattice constant is about 3.4 Å. (d) The TEM pictures for laser-irradiated CNT with some sheet-shaped layers surrounded by dash line. The magnified image of squared area is shown in the inset and a lattice constant of about 3.4 Å is measured.

For the glucose sensing measurements, the sensing head and reference electrode were immersed in the different glucose solutions with a commercial instrumentation amplifier (ICLT1167) and a digital multi-meter (HP 34401A). All measurements were carried out in a dark box at room temperature. The output voltage–time ($V-t$) measurement systems are shown in Fig. 1(b).

3. Results and discussion

Fig. 2(a) and (b) shows the high-resolution scanning electron microscopy (HR-SEM) pictures of CNTFs before and after laser irradiation, respectively. The as-sprayed MWCNTs are randomly distributed as the continuous wires, as shown in Fig. 2(a). After the laser irradiation, a significantly changed morphology of the CNTF could be observed in Fig. 2(b). The original wire-shaped structure is almost altered to enlarged wire segments. To further realize the effect of laser irradiation on the CNTs, the transmission electron microscopy (TEM) pictures are investigated as shown in Fig. 2(c) and (d), respectively. For the as-sprayed CNTF, the sidewalls of CNTs are etched to be irregular and several concave holes are observed, as indicated by the arrows in Fig. 2(c). It was reported [7,8] that acids, a mixture of H_2SO_4 and HNO_3 in this work, would make sidewalls of CNTs bond with oxygen-containing groups to form some structure defects. As the duration of acid treatment increased, concave holes on the surface could be observed. After the laser irradiation, CNTs are unzipped into numerous sheet-shaped layers surrounded by dash line, as demonstrated in Fig. 2(d). To confirm the structures of these sheet layers, a lattice constant of about 3.4 Å is measured from the magnified image, as shown in the inset of Fig. 2(d), which

implies that these sheet layers still maintain graphite structure even after the laser irradiation.

The normalized Raman spectra of CNTFs indicate that the intensity ratio of D band (Raman shift at about 1350 cm^{-1}) to G band (at about 1580 cm^{-1}), I_D/I_G , is about 1.02 for the as-sprayed CNTF and 1.31 for the laser-irradiated one, as shown in Fig. 3. Such a high ratio of I_D/I_G for the as-sprayed CNTF represents the existence of defects induced by the acid treatment and this can also be confirmed by the TEM image as mentioned in Fig. 2(c). After the laser irradiation, the

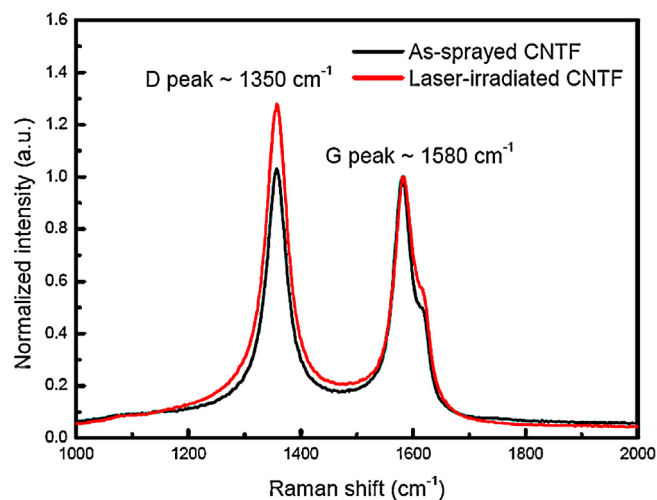

Fig. 3. Raman spectra of as-sprayed and laser-irradiated CNTF, respectively.

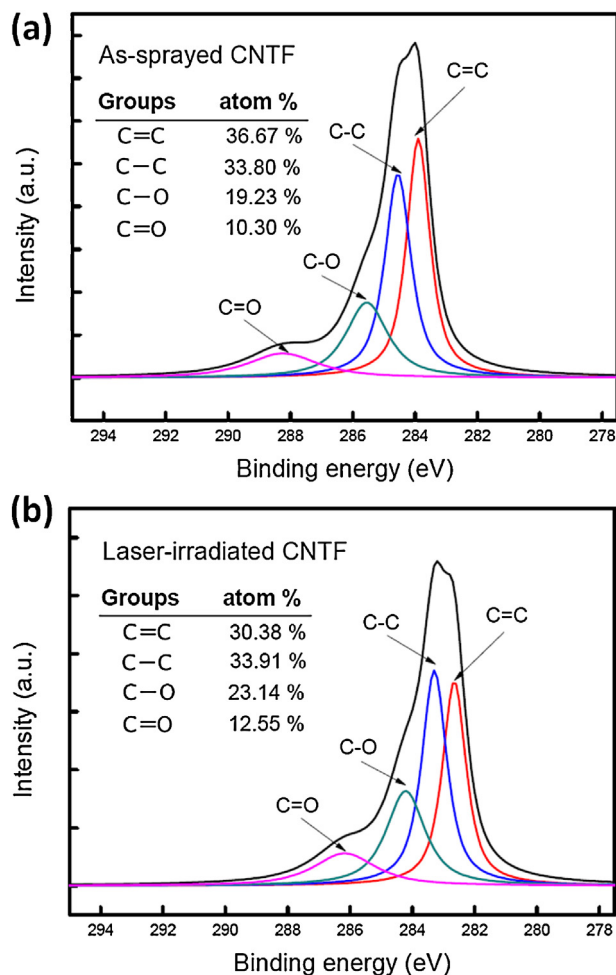

Fig. 4. XPS analyses for (a) as-sprayed and (b) laser-irradiated CNTF with the quantitative analyses exhibited in the figures, respectively.

laser-irradiated CNTF attains a still higher I_D/I_G ratio of 1.31 which is attributed to the extra site edges from the unzipped CNTs.

X-ray photoelectron spectroscopy is performed to examine the decorated functional groups on CNTs after laser treatment, as shown in Fig. 4. Both the high-resolution XPS C 1s spectra of as-sprayed CNTF and laser-irradiated one can be deconvoluted into five component Gaussian peaks. The main peak at 284.1 eV is attributed to the sp^2 -hybridized C=C bonds. The peak at 285.1 eV is corresponding to the sp^3 -hybridized C-C bonds. Other peaks at 286.2 and 287.2 eV are considered to originate in carbon atoms bonded to one oxygen atom with a single bond and one oxygen atom with double bonds, respectively. As compared to the quantitative analysis between the as-sprayed CNTF and laser-irradiated one, correspondingly depicted in Fig. 4(a) and (b), it is obvious that the quantity of sp^2 C=C bonds decrease but the oxygen-containing groups, such as C-O and C=O bonds, increase after laser irradiation.

The sheet resistance of CNTF measured by four-point probe versus the spraying times is shown in Fig. 5. For the as-sprayed CNTF, the sheet resistance decreases from 331 K to 33 K Ω /sq as the spraying times increases from 3 to 10 times. After laser irradiation, the sheet resistance of the laser-irradiated CNTF can remarkably decrease to 29 K Ω /sq even for the spraying times as low as 3 times and decrease to 1 K Ω /sq for 10 times. The sheet resistance of 3-times-sprayed CNTF can be reduced by over 10 times after laser irradiation as compared with the as-sprayed one. Furthermore, the laser-irradiated CNTFs possess much lower resistance variation,

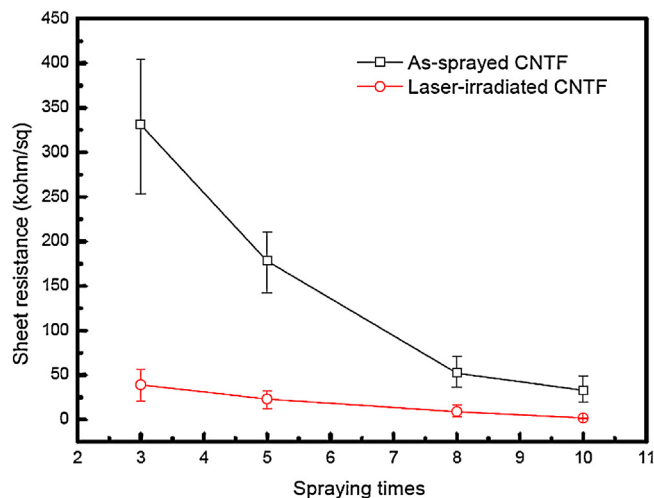

Fig. 5. Sheet resistances of CNTFs with different spraying times for as-sprayed and laser-irradiated CNTFs.

reflecting a more uniform film for the laser-irradiated CNTF than the as-sprayed one.

The schematic diagram of the sensing head structure is depicted in Fig. 6(a). Before GOD immobilizing process, the pH-sensing characteristics of as-sprayed CNTF and laser-irradiated one, with 10-times spraying, are examined as well. The transfer characteristics (drain current versus reference electrode voltage, $I_{DS}-V_{REF}$) for the pH-EGFET sensors in the linear region with as-sprayed CNTF and laser-irradiated one are shown in Fig. 6(b) for V_{DS} fixed at 0.2 V and V_{REF} varied from 0 to 4 V. The $I_{DS}-V_{REF}$ curves in the linear region for these pH-sensing films exhibit that the threshold voltages shift from left to right with decreasing hydrogen ions concentration in the range of pH 1–13. The sensitivity and linearity of both CNTFs could be calculated from the slopes of the V_{REF} defined at a fixed I_{DS} of 0.2 mA and V_{DS} of 0.2 V as a function of the pH value, as shown in the inset of Fig. 6(b). Consequently, the sensitivities of the as-sprayed CNTF and laser-irradiated one are 33.6 mV/pH and 45.2 mV/pH, respectively. Furthermore, the extracted pH voltage linearity for the laser-irradiated one is 0.9956 much better than 0.9510 for the as-sprayed one. The $V-t$ characteristics of the as-sprayed CNTF and laser-irradiated one as glucose sensing films of glucose sensors in the 60–360 mg/dl glucose concentrations are shown in Fig. 6(c) and (d), respectively. The output voltage is measured for the 30-second duration for each glucose solution and the output voltage shift depends upon the glucose concentration. The calibration curves of both glucose biosensors at glucose concentrations ranging from 60–360 mg/dl are shown in the inset of Fig. 6(c) and (d), respectively. It is evident that the laser-irradiated glucose biosensor demonstrates a rapid and sensitive response to the variation of glucose concentration. The sensitivity of laser-irradiated glucose biosensor is $0.302 \text{ mV}(\text{mg/dl})^{-1}$, equal to $7.55 \text{ mV}(\text{mg/dl})^{-1}$ per centimeter square, much better than $0.16 \text{ mV}(\text{mg/dl})^{-1}$, equal to $4.0 \text{ mV}(\text{mg/dl})^{-1}$ per centimeter square, for as-sprayed one. Moreover, the extracted linearities of the laser-irradiated and as-sprayed glucose biosensors were 0.9947 and 0.9881, respectively, indicating the laser-irradiated glucose biosensor could take a much linear response to different glucose concentrations from 60 to 360 mg/dl.

A possible mechanism is proposed to explain the effect of continuous-wave laser irradiation on the CNTF. The photon energy of the continuous-wave laser used in this work is about 2.3 eV, which is much lower for breaking C-C (3.4 eV) or C=C (7.4 eV) bonds [12], therefore, the heat generated by the light absorption of CNTF plays the dominant role for the unzipping of CNTs. As the

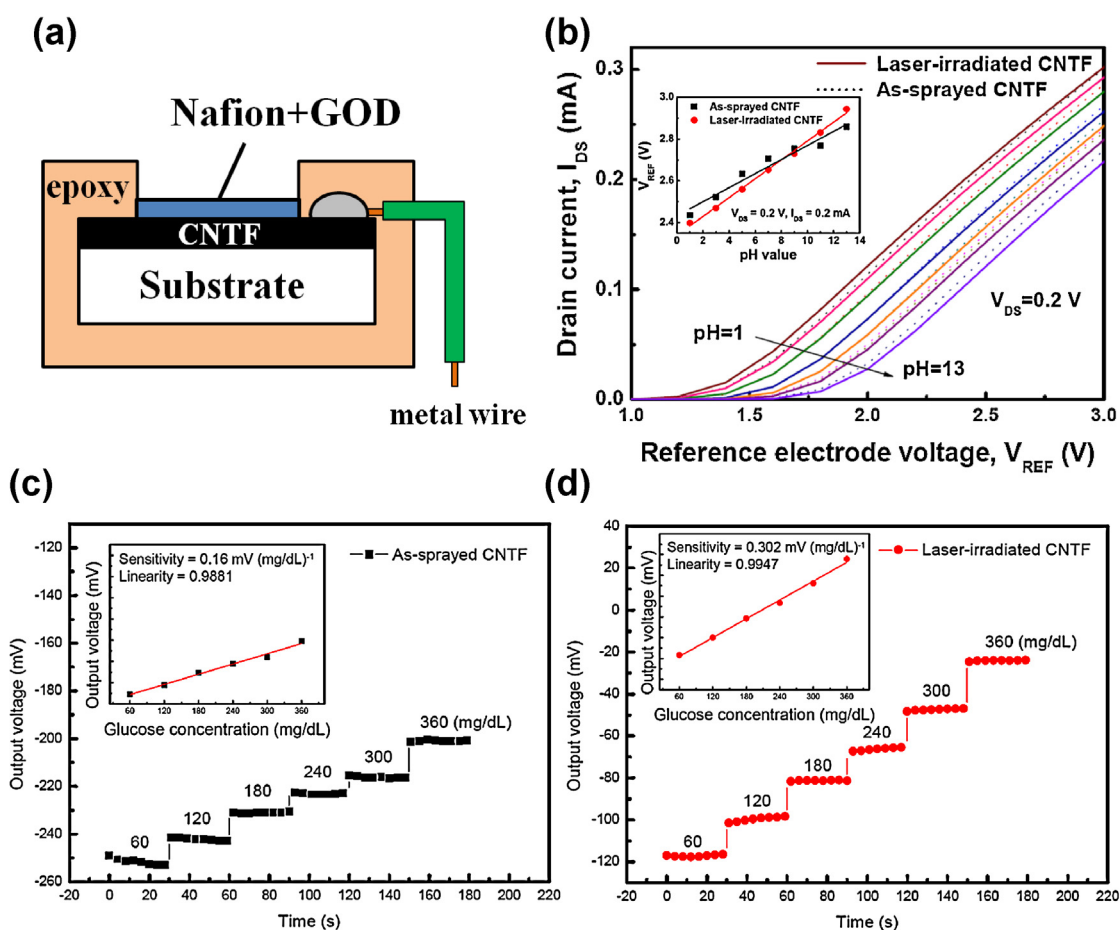

Fig. 6. (a) The schematic diagram of the glucose sensing head structure. (b) The transfer characteristics, I_{DS} – V_{REF} , of the pH-EGFET sensors in the linear region for the as-sprayed CNTF and laser-irradiated one. The extracted pH voltage sensitivity and linearity for as-sprayed CNTF and laser-irradiated one are shown in the inset of (b). The V – t characteristics of the (c) as-sprayed and (d) laser-irradiated CNTFs as sensing films of glucose biosensors in the 60–360 mg/dl glucose concentrations. The calibration curves of both glucose biosensors at glucose concentrations ranging from 60 to 360 mg/dl are shown in the insets, respectively.

continuous-wave laser with wavelength of 532 nm irradiates on CNTs, CNTs then unzipped into numerous sheet layers. These sheet layers possess higher conductance owing to larger contact area as compared to the as-sprayed CNTs only connect others at contacts. Accordingly, laser-irradiated CNTF can immediately transmit signals because of its higher electrical conductance. Moreover, the laser-irradiated CNTF also supplies additional sensing sites for the adsorption of hydrogen ions. Though, both the surfaces of as-sprayed CNT and laser-unzipped one have already been decorated with oxygen-containing functional groups after the acid treatment, and these functional groups could assist H^+ ion sensing [13]. After laser irradiation, the extra site edges of unzipped CNTs will partially form functional groups such as carbonyl and C–H bonds [14]. Therefore, additional sensing sites after laser irradiation make the laser-irradiated CNTF exhibit high-performance glucose sensing characteristics as compared to the as-sprayed ones.

4. Conclusion

In summary, a more accurate and precise glucose biosensor with laser-irradiated CNTF has been developed. After the laser irradiation, CNTs are unzipped into numerous sheet layers, and these sheet layers can supply sufficient sensing sites for the detection of hydrogen ions and transmit signals immediately. Therefore, The sensitivity and linearity of laser-irradiated CNTF as a sensing film of glucose biosensor are $0.302 \text{ mV (mg/dl)}^{-1}$, equal to $7.55 \text{ mV (mg/dl)}^{-1}$ per centimeter square, and 0.9947 much better

than the as-sprayed one. This approach implies the ultrasonic-sprayed CNTF irradiated by continuous-wave laser are promising for the practical applications in flexible and disposable biosensors.

Acknowledgments

The authors at NCTU thank the National Science Council of Republic of China for their support under contract NSC 101-2221-E-009-077-MY3. Thanks are also due to the Nano Facility Center (NFC) in National Chiao Tung University and the National Nano Device Laboratory (NDL) for the technical supports.

References

- [1] S. Caras, J. Janata, Field effect transistors sensitive to penicillin, *Anal. Chem.* **52** (1980) 1935–1937.
- [2] N.H. Chou, J.C. Chou, T.P. Sun, S.K. Hsiung, Differential type solid-state urea biosensors based on ion-selective electrodes, *Sens. Actuators B: Chem.* **130** (2008) 359–366.
- [3] H.I. Seo, C.S. Kim, B.K. Sohn, T. Yeow, M.T. Son, M. Haskard, ISFET glucose sensor based on a new principle using the electrolysis of hydrogen peroxide, *Sens. Actuators B* **40** (1997) 1–5.
- [4] J.M. Nugent, K.S.V. Santhanam, A. Rubio, P.M. Ajayan, Fast electron transfer kinetics on multiwall carbon nanotube microbundle electrodes, *Nano Lett.* **1** (2001) 87–91.
- [5] Y.H. Yang, W.Z. Li, Radial elasticity of single-walled carbon nanotube measured by atomic force microscopy, *Appl. Phys. Lett.* **98** (2011) 041901–41903.
- [6] M.F. Yu, O. Lourie, M.J. Dyer, K. Moloni, T.F. Kelly, R.S. Ruoff, Strength and breaking mechanism of multiwalled carbon nanotubes under tensile load, *Science* **287** (2000) 637–640.

- [7] A.F. Holloway, G.G. Wildgoose, R.G. Compton, L. Shao, L.H. Malcolm, Green, The influence of edge-plane defects and oxygen-containing surface groups on the voltammetry of acid-treated, annealed and super-annealed multiwalled carbon nanotubes, *J. Solid State Electrochem.* 12 (2008) 1337–1348.
- [8] T.M. Wu, Y.W. Lin, C.S. Liao, Preparation and characterization of polyaniline/multi-walled carbon nanotube composites, *Carbon* 43 (2005) 734–740.
- [9] Y.S. Chien, W.L. Tsai, I.C. Lee, J.C. Chou, H.C. Cheng, A novel pH sensor of extended-gate field-effect transistors with laser-irradiated carbon-nanotube network, *IEEE Electron Device Lett.* 33 (2012) 1622–1624.
- [10] M.S. Fuhrer, J. Nygard, L. Shih, M. Forero, Y. Yoon, M.S.C. Mazzoni, H.J. Choi, J. Ihm, S.G. Louie, A. Zettl, P.L. McEuen, Crossed nanotube junctions, *Science* 288 (2000) 494–497.
- [11] Y.S. Chien, P.Y. Yang, W.L. Tsai, Y.R. Li, C.H. Chou, J.C. Chou, H.C. Cheng, The pH sensing characteristics of the extended-gate field-effect transistors of multi-walled carbon-nanotube thin film using low-temperature ultrasonic spray method, *J. Nanosci. Nanotechnol.* 12 (2012) 5423–5428.
- [12] A. Rubio, S.P. Apell, L.C. Venema, C. Dekker, A mechanism for cutting carbon nanotubes with a scanning tunneling microscope, *Eur. Phys. J. B* 17 (2000) 301–308.
- [13] D.E. Yates, S. Levine, T.W. Healy, Site-binding model of the electrical double layer at the oxide/water interface, *J. Chem. Soc., Faraday Trans.* 70 (1974) 1807–1818.
- [14] Y.G. Hwang, Y.H. Lee, Adsorption of H₂O molecules at the open ends of single-walled carbon nanotubes, *J. Korean Phys. Soc.* 42 (2003) S267–S271.

Biographies

Wan-Lin Tsai was born in 1986. He received the B.S. degree in Electronics Engineering from National Chiao-Tung University in 2008. He is presently a Ph.D. student at

the Department of Electronics Engineering in National Chiao-Tung University. His research interests include biosensor, carbon nanotube and electronic devices.

Yun-Shan Chien was born in 1986. She received the B.S. degree in Physics from National Tsing-Hua University in 2008. She is presently a Ph.D. student at the Department of Electronics Engineering in National Chiao-Tung University. Her research interests include carbon nanotube and field emission.

Po-Yu Yang was born in 1983. He received the Master degree in the Institute of Display from National Chiao-Tung University in 2007. He received the Ph.D. degree in the Department of Electronics Engineering from National Chiao-Tung University. His research interests include nanomaterials and electronic devices.

I-Che Lee was born in 1978. He received the Master degree in the Institute of Display from National Chiao-Tung University in 2006. He received the Ph.D. degree in the Department of Electronics Engineering from National Chiao-Tung University. His research interests include thin-film transistors and electronic devices.

Kuang-Yu Wang was born in 1988. He received the B.S. degree in Materials Science and Engineering from National Tsing-Hua University in 2006. He is presently a Ph.D. student at the Department of Electronics Engineering in National Chiao-Tung University. His research interests include nanomaterials and biosensors.

Dr. Huang-Chung Cheng is a professor of Department of Electronics Engineering in National Chiao-Tung University. He received the B.S. degree in physics from National Taiwan University in 1977, and the M.S. and Ph.D. degrees from the Department of Materials Science and Engineering, National Tsing-Hua University, Hsinchu, Taiwan, in 1979 and 1985, respectively. He has published nearly 500 technical papers in international journals and conferences, and also held more than 50 patents. His current research interests are in the areas of high-performance TFTs, novel nanowire devices, non-volatile memories, three-dimensional integrations, novel field emission displays, biosensors, and photoelectronic device.