

Improved N-port optical quasi-circulator by using a pair of orthogonal holographic spatial- and polarization- modules

Jing-Heng Chen

*Department of Photonics, Feng Chia University,
100 Wenhwa Road, Seatwen, Taichung 40724, Taiwan, R.O.C.
jhchen@fcu.edu.tw*

Po-Jen Hsieh, Jiun-You Lin and Der-Chin Su

*Department of Photonics & Institute of Electro-Optical Engineering,
National Chiao Tung University, 1001 Ta Hsueh Road, Hsin-Chu 30050, Taiwan, R.O.C.*

Abstract: Based on the flexibilities of light beam propagation in three dimensions, we propose an improved N-port optical quasi-circulator by using a pair of orthogonal holographic spatial- and polarization- modules. All optical elements are located in parallel planes that are perpendicular to the optical axis. The number of optical elements is decreased, and a higher performance optical quasi-circulator without crosstalk and polarization mode dispersion can be easily achieved. A prototype of 5-port polarization-independent optical quasi-circulator operating at a wavelength of 1300nm was assembled and tested to show its validities.

©2004 Optical Society of America

OCIS codes: 060.4510 (Optical communications); 090.2890 (Holographic optical elements); 260.5430 (Polarization).

References and links

1. N. Sugimoto et al. "Waveguide polarization-independent optical circulator," *IEEE Photon. Technol. Lett.* **11**, 355-357 (1999).
2. L. D. Wang, "High-isolation polarization-independent optical quasi-circulator with a simple structure," *Opt. Lett.* **23**, 549-551 (1998).
3. M. Koga, "Compact quartzless optical quasi-circulator," *Electron. Lett.* **30**, 1438-1440 (1994).
4. Y. K. Chen et al. "Low-crosstalk and compact optical add-drop multiplexer using a multiport circulator and fiber Bragg gratings," *IEEE Photon. Technol. Lett.* **12**, 1394-1396 (2000).
5. A. V. Tran et al. "A bidirectional optical add-drop multiplexer with gain using multiport circulators, fiber Bragg gratings, and a single unidirectional optical amplifier," *IEEE Photon. Technol. Lett.* **15**, 975-977 (2003).
6. Y. Sato and K. Aoyama, "OTDR in optical transmission systems using Er-doped fiber amplifiers containing optical circulators," *IEEE Photon. Technol. Lett.* **3**, 1001-1003 (1991).
7. J. H. Chen et al. "Multi-port polarization-independent optical circulators by using a pair of holographic spatial- and polarization- modules," *Opt. Express* **12**, 601-608 (2004), <http://www.opticsexpress.org/abstract.cfm?URI=OPEX-12-4-601>.
8. J. H. Chen et al. "Holographic spatial walk-off polarizer and its application to a 4-port polarization-independent optical circulator," *Opt. Express* **11**, 2001-2006 (2003), <http://www.opticsexpress.org/abstract.cfm?URI=OPEX-11-17-2001>.
9. B. J. Chang, *Optical information storage*, Proc. SPIE, vol. **177**, 71-81 (1979).

1. Introduction

Optical circulators [1-6] are important passive devices that have nonreciprocal functions. They can be divided into two types, one with a perfect circular propagation structure and the other with an imperfect circular propagation structure; the latter is also termed as a quasi-

circulator. In our previous paper, we proposed a multi-port polarization-independent optical quasi-circulator by using a pair of holographic spatial- and polarization- modules (HSPMs) [7]. Each HSPM consists of a pair of holographic spatial walk-off polarizers (HSWPs) [8], a 45° Faraday rotator, and a 45° half wave-plate. Although it has many advantages such as polarization-independence, compactness, high isolation, low polarization mode dispersion, easy fabrication, and the number of ports can be scaled up easily, its optical components and its optical routes are restricted in one plane including the optical axis. Consequently, it has two main drawbacks. First, the cross talk is hardly avoided because of the nonideal diffraction efficiency of an HSWP, and so isolation of each port could be deteriorated. Second, more prisms and polarization beam-splitters should be added at special locations to decrease polarization mode dispersion. They make the configuration to be complicated and difficult to be assembled, especially for lower ports because of its limited space.

In this paper, in order to improve these drawbacks, we propose an N-port optical quasi-circulator by using a pair of orthogonal HSPMs. The light propagation paths of two orthogonal polarization components of each route in these two HSPMs are in two orthogonal planes that contain the optical axis, respectively. Both the two-polarization components have the same number of diffraction and the same number of total internal reflection in these two HSPMs, so their optical path lengths are equivalent. Consequently, only fewer prisms and polarization beam-splitters are necessary to guide the light beams in and out of the module. The number of optical elements is decreased and the optical configuration becomes much more simpler. In addition, the light leakages produced by the nonideal diffraction efficiencies of the HSWP do not enter any other port. There is no crosstalk between any port, and every port has a higher isolation. To demonstrate the feasibility, the prototype of a 5-port polarization-independent optical quasi-circulator operating at a wavelength of 1300nm was assembled. Its operating principles and the performance of this device are discussed.

2. Principles

2.1 Holographic spatial- and polarization- module

An HSPM is composed of a pair of holographic spatial walk-off polarizers HSWP₁ and HSWP₂, a 45° Faraday rotator (FR), and a 45° half wave-plate (H), as shown in Fig. 1. An orthogonal x-y-z coordinate system with unit displacement L is utilized to characterize the beam propagation direction and the associated spatial location. The light propagates along either the +z or the -z direction; symbols \oplus and \ominus represent the u- and the v- polarized components, respectively, and symbol \oplus represents the light beam that has both the u- and the v- polarized components. In Fig. 1(a), when an unpolarized light is incident along the +z direction on the HSPM, the u- polarized component passes through the HSWP₁ directly. The v- polarized component, however, passes through the HSWP₁ after two diffractions and two total-reflections. Here the displacement between these two orthogonally polarized components is L. Next, light beams pass through FR and H, and their states of polarization (SOPs) are rotated a total of 90° , with $+45^\circ$ by FR and $+45^\circ$ by H, respectively. They finally enter the HSWP₂, and with similar diffraction and total-reflection effects as in the HSWP₁ they recombine together at the output. Therefore, the outgoing light of this HSPM is unpolarized and shifted spatially with a displacement L along the -y direction.

In Fig. 1(b), when an unpolarized light is incident along the -z direction on the HSPM, the u- polarized component passes through the HSWP₂ directly and the v- polarized component also passes through the HSWP₂ after two diffractions and two total-reflections. The displacement between the u- and v- polarized components now is L. Next, these two orthogonally polarized components pass through H and FR, and their SOPs are rotated a total of 0° , with -45° by H and $+45^\circ$ by FR, respectively. Finally, the u- polarized component passes through the HSWP₁ directly; but the v- polarized component passes through the HSWP₁ after two diffractions and two total-reflections more. This time an additional displacement L along the +y direction is added between these two orthogonally polarized components. Therefore, the u- polarized component is transmitted directly through the HSPM

while the v- polarized component is shifted spatially with a total displacement $2L$ along $+y$ direction and then transmitted. For clearness, we define this HSPM as HSPM_y because their output lights are shifted spatially on the y -axis.

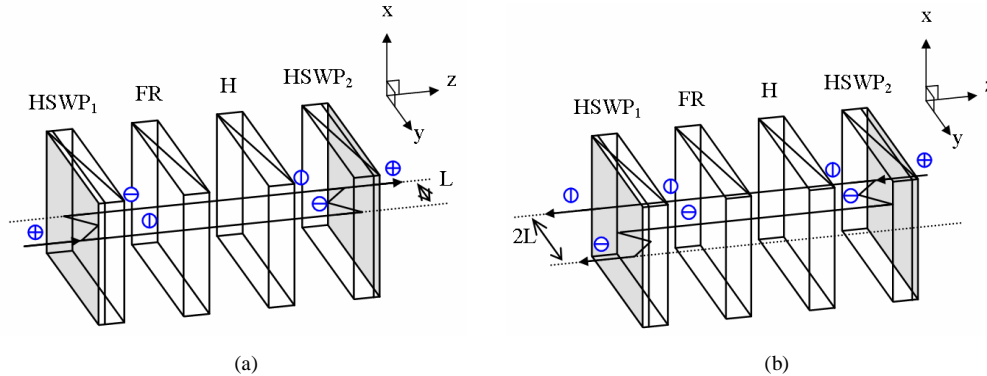

Fig. 1. Three dimensional structure and operational characteristics of the holographic spatial- and polarization- module.

According to the previously described operational characteristics, when the HSPM_y is rotated 90° clockwise with respect to $+z$ axis (viewing from HSWP_1 to HSWP_2), the outgoing unpolarized light of the rotated HSPM will be shifted spatially with a displacement L along the $+x$ direction as an unpolarized light being incident along the $+z$ direction. On the other hand, the v- polarized component is transmitted directly through the rotated HSPM while the u- polarized component is shifted spatially with a displacement $2L$ along the $-x$ direction and then transmitted, when an unpolarized light is incident along the $-z$ direction. Similarly, we call the rotated HSPM as HSPM_x because their output lights are shifted spatially on the x -axis.

Based on the above principles, we assemble a module by connecting a pair of HSPM_x and HSPM_y sequentially together. The operational characteristics are shown in Figs. 2(a) and 2(b). In Fig. 2(a), when an unpolarized light is incident along the $+z$ direction on the module, the outgoing unpolarized light is shifted spatially with a displacement L along the $+x$ and the $-y$ directions respectively. In Fig. 2(b), when an unpolarized light is incident along the $-z$ direction on the module, the u- and the v- polarized components are separately shifted spatially with a displacement $2L$ along the $-x$ and the $+y$ directions, and then transmitted.

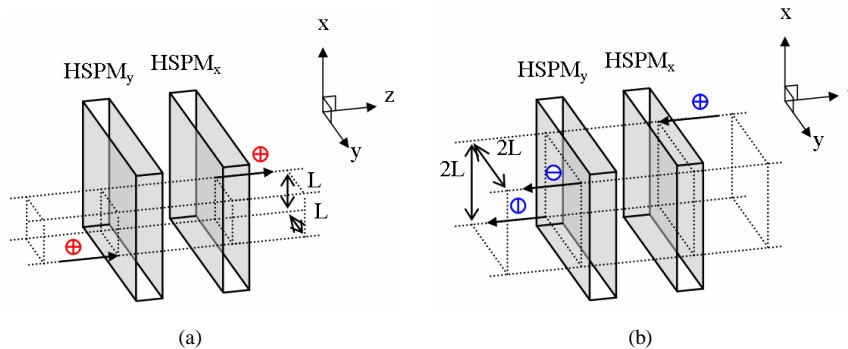

Fig. 2. Structure and operational characteristics of a module by connecting a pair of HSPM_x and HSPM_y .

Therefore, the spatial positions of the input and output of the u- and the v- polarized components of each channel are shown in Fig. 3, in which the module is applied to an optical quasi-circulator. In this figure, the characters u and v represent the u- and the v- polarized components, the number after these characters indicate the port number, n is a positive integer,

and the arrows indicate the propagation direction of the light, respectively. When an unpolarized light is shuttled between the two sides of the module, the u- and the v- polarized components are separated in two opposite directions gradually along the slanted lines $y=x$ and $y=x-2$, respectively. For convenience, let the HSPM_y and the HSPM_x be located at $z = -L$ and $z = L$, the odd $(2n-1)$ ports be in the $-z$ region, and the even $(2n)$ ports be in the $+z$ region, then the positions of the u- and the v- polarized components at the j -th port can be expressed as (x_{uj}, y_{uj}) and (x_{vj}, y_{vj}) , respectively. Here subscripts u and v denote the u- and the v- polarized components, the numbers $(2n-1)$ and $(2n)$ after these characters indicate port numbers. Suppose the initial positions of the first port are at $(x_{u1}, y_{u1}, z_{u1})=(x_{v1}, y_{v1}, z_{v1})=(0, 0, -L)$, then the corresponding positions of the polarized components at two sides of the module can be expressed as

$$\begin{bmatrix} x_{u(2n-1)} & y_{u(2n-1)} \\ x_{v(2n-1)} & y_{v(2n-1)} \end{bmatrix}_{z=-L} = \begin{bmatrix} (1-n)L & (1-n)L \\ (n-1)L & (n-1)L \end{bmatrix}_{z=-L}, \quad (\text{for an odd port}) \quad (1)$$

and

$$\begin{bmatrix} x_{u(2n)} & y_{u(2n)} \\ x_{v(2n)} & y_{v(2n)} \end{bmatrix}_{z=L} = \begin{bmatrix} (2-n)L & -nL \\ nL & (n-2)L \end{bmatrix}_{z=L}. \quad (\text{for an even port}) \quad (2)$$

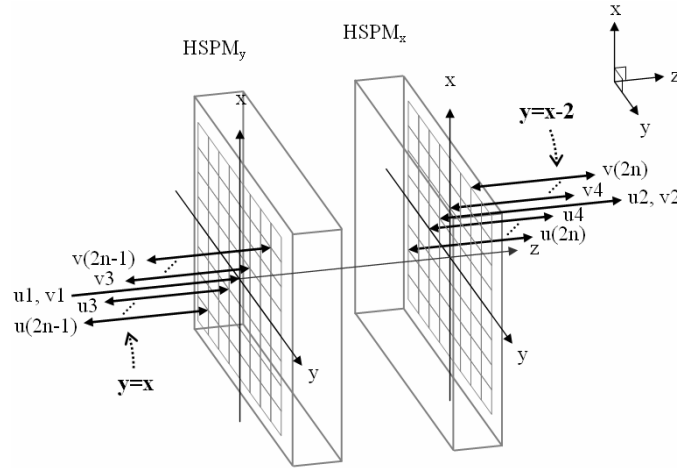

Fig. 3. Operational characteristics of the module when an unpolarized light is shuttled between the two sides.

2.2 Multi-port polarization-independent optical quasi-circulator

It is obvious that if reflection prisms (RPs) and polarization beam-splitters (PBSs) are introduced appropriately to guide the light beams in and out of the module, we can obtain a multi-port optical quasi-circulator. Only one RP should be added at port 1 and port 2 separately. For other ports, each port needs two RPs and one PBS. According to Eqs. (1) and (2), the introduced RPs and PBS at the j -th port are located at (x_{RP1j}, y_{RP1j}) , (x_{RP2j}, y_{RP2j}) and (x_{PBSj}, y_{PBSj}) , which can be expressed as

$$\begin{bmatrix} x_{RP1(2n-1)} & y_{RP1(2n-1)} \\ x_{RP2(2n-1)} & y_{RP2(2n-1)} \\ x_{PBS(2n-1)} & y_{PBS(2n-1)} \end{bmatrix}_{z=-L} = \begin{bmatrix} (1-n)L & (1-n)L \\ (n-1)L & (n-1)L \\ (n-1)L & (1-n)L \end{bmatrix}_{z=-L}, \quad (\text{for an odd port}) \quad (3)$$

$$\begin{bmatrix} x_{RP1(2n)} & y_{RP1(2n)} \\ x_{RP2(2n)} & y_{RP2(2n)} \\ x_{PBS(2n)} & y_{PBS(2n)} \end{bmatrix}_{z=L} = \begin{bmatrix} (2-n)L & -nL \\ nL & (n-2)L \\ nL & -nL \end{bmatrix}_{z=L}. \quad (\text{for an even port}) \quad (4)$$

These equations are still valid for port 1 and port 2 to determine the position of its associated RP. Shown in Fig. 4 is a 5-port polarization-independent optical quasi-circulator consisting of a pair of HSPM_x and HSPM_y, 3 PBSs, and 8 RPs. Figures 4(a) and 4(b) show the routes of port 1→port 2 and port 4→port 5, respectively. Based on the same principle, other propagation and expanded routes can also be obtained.

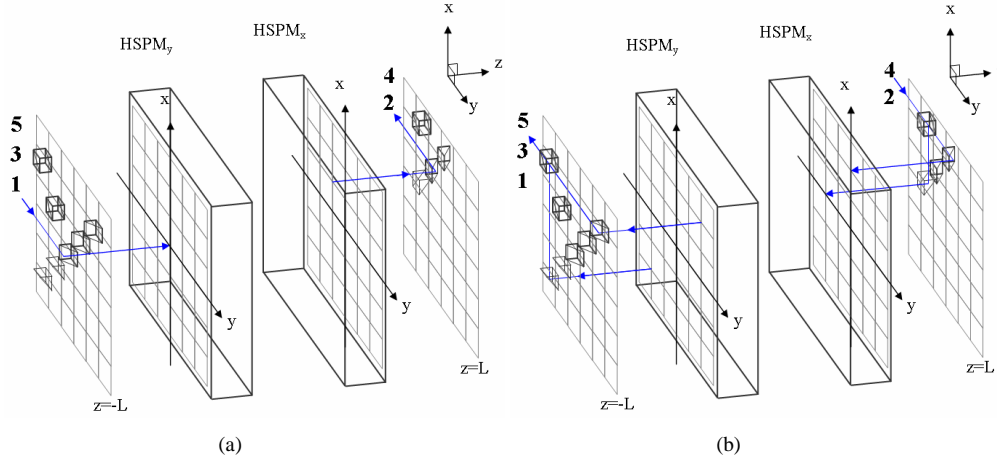

Fig. 4. Structure and operation principles of the proposed 5-port polarization-independent optical quasi-circulator.

3. Experimental results and discussions

In order to demonstrate the validity of our design, we used our fabricated HSPMs to assemble a prototype of 5-port polarization-independent optical quasi-circulator for 1300nm. Each HSPM has a pair of HSHPs, a 45° FR and a 45° H. The HSHP's diffraction efficiencies of u- and v- polarized components were measured to be $\eta_u=3\%$ and $\eta_v=90\%$ with a diffraction angle of 60°. The transmittances of FR and H, which are commercial devices, are listed to be 0.95 and 0.97, respectively. In addition to a pair of orthogonal HSPMs, it needs another three PBSs and eight RPs to complete the function of this 5-port polarization-independent optical quasi-circulator. Its associated losses and isolation values can be estimated, as shown in Table 1(a). The isolation values are in the range from 20 to 54dB. The return losses and the insertion losses are about 14dB and about 3dB, respectively. In order to confirm the validity of this estimation, we have measured its insertion losses. The measured values are correspondent well with the estimated values. Return losses mainly come from the interface reflections that influence the isolation values directly. If our fabricated HSHPs are anti-reflection coated and are fabricated under accurate fabrication processes, the return losses could be over 50 dB and the diffraction efficiencies may reach theoretical values [9], i.e., $\eta_u=0\%$ and $\eta_v=100\%$. Under these two improved conditions, the performance of this 5-port optical quasi-circulator can be enhanced greatly, and the associated parameters are calculated as $\eta_u<1\%$ and $\eta_v>99\%$ and listed in Table 1(b). From this table, it can be seen that the isolation values can be larger than 51dB and the insertion losses are smaller than 0.9dB.

Compared with that in our previous paper [7], only the second HSPM is rotated 90° clockwise in this improved device. So it still has all the advantages of the previous one. In

addition, because two orthogonally polarized components have the same numbers of diffractions and total internal reflections in this design, their optical path lengths are the same. Consequently, only fewer PBSs and RPs are required to guide the light beams in and out of the module. Hence its optical configuration is simpler and it is easier to be assembled. Moreover, the optical paths and the optical elements are not restricted in the same plane as the previous one. So the light leakages producing by the nonideal diffraction efficiencies of the HSWPs can not enter any port. The crosstalk between any port can be avoided. Hence it has higher isolations. In this device, a substrate-mode holographic grating is used to replace a conventional crystal spatial walk-off polarizer, which has a larger dimension. Compared with a conventional quasi-circulator, this device has some other merits such as compactness, easy fabrication, and low-cost. So it might have potential in optical communications.

Table 1 Associated losses and isolation values (in Decibels) of a 5-port quasi-circulator with a wavelength of 1300nm by using (a) our fabricated HSWPs; (b) ideal HSWPs with anti-reflection coatings and diffraction efficiencies of $\eta_u < 1\%$ and $\eta_v > 99\%$.

(a)

In Port	Out Port				
	1	2	3	4	5
1	14.26 ^b	3.26 ^c	>20.46	>37.65	>54.85
2	>54.85	14.26 ^b	3.26 ^c	>20.46	>37.65
3	>37.65	>54.85	14.26 ^b	3.26 ^c	>20.46
4	>54.85	>54.85	>54.85	14.26 ^b	3.26 ^c

(b)

In Port	Out Port				
	1	2	3	4	5
1	>50 ^b	<0.89 ^c	>51.77	>102.65	>102.65
2	>102.65	>50 ^b	<0.89 ^c	>51.77	>102.65
3	>102.65	>102.65	>50 ^b	<0.89 ^c	>51.77
4	>102.65	>102.65	>102.65	>50 ^b	<0.89 ^c

^aAll values without a superscript are isolation values; ^bReturn losses; ^cInsertion losses.

4. Conclusions

In this paper, based on the flexibilities that light beams propagate in three dimensions, we have proposed an improved N-port optical quasi-circulator by using a pair of orthogonal holographic spatial- and polarization- modules. In addition to the advantages of that in our previous paper, the optical configuration is simpler and easier to be assembled, and a higher performance can be achieved easily. To demonstrate the feasibility, a prototype of 5-port polarization-independent optical quasi-circulator operating at a wavelength of 1300nm was assembled and tested. Its operating principles and performance are discussed.

Acknowledgments

This research was supported partially by grants from the National Science Council, Taiwan, ROC, under contract No. NSC-92-2215-E-009-052, and the Lee & MTI Center for Networking at National Chiao Tung University, Taiwan, ROC.