

Novel method to stabilize a laser wavelength unaffected by Fabry-Perot etalon angle drift

Mao-Sheng Huang

National Chiao Tung University
Institute of Electro-Optics Engineering
Hsinchu 300, Taiwan
and
Center for Measurement Standards
Taiwan
E-mail: Mao-Sheng@itri.org.tw

Mao-Hong Lu, MEMBER SPIE

National Chiao Tung University
Institute of Electro-Optics Engineering
Hsinchu 300, Taiwan

Jow-Tsong Shy

National Tsing Hua University
Department of Physics
Hsinchu 300, Taiwan

Abstract. A laser with its wavelength stabilized to a Fabry-Perot etalon has many industrial applications. An ideal error signal for laser stabilization is the dispersion-like signal generated without wavelength modulation. We present a technique, by which the error signal is generated by the difference of two resonance peaks of a Fabry-Perot etalon. A laser beam is split into two beams, which pass through an etalon with a small optical path length difference to generate two partially overlapped resonance peaks. Subtracting one peak from the other yields a dispersion-like error signal. The zero crossing of the differential signal is insensitive to the angle drift of the etalon if the incident angles of the two laser beams are nearly equal but with opposite sign. © 2004 Society of Photo-Optical Instrumentation Engineers. [DOI: 10.1117/1.1690278]

Subject terms: Fabry-Perot; etalon; differential signal; laser stabilization.

Paper 030231 received May 16, 2003; revised manuscript received Oct. 9, 2003; accepted for publication Nov. 3, 2003.

1 Introduction

Laser wavelength stabilization is an important technology for applications in laser interferometry, wavelength standards, and dense wavelength division multiplexing (DWDM) communications. Atomic or molecular spectra are popular wavelength references for wavelength standards¹⁻⁵ because of their high wavelength repeatability and sharp spectral peaks. A laser can be stabilized to one of these spectral lines and reach very high wavelength stability. However, ultimate stability is not often required in most industrial applications. Stabilizing a laser to a Fabry-Perot etalon is another convenient choice. A Fabry-Perot etalon has several resonance modes with different wavelengths, and the resonance wavelengths can be tuned by changing the optical path of the light in the etalon.⁶ Some Fabry-Perot etalons are composed of two highly reflective mirrors and a low thermal expansion spacer; some are just solid state etalons. The former can be used to reach high stability in laser stabilization,^{7,8} while the latter are usually made cheap and robust, which are appropriate for industrial applications. A Fabry-Perot etalon does not have a structure that modulates the resonance signal to yield a zero-crossing error signal for laser stabilization. Several methods are frequently used for generating error signals with zero crossing. For example, directly modulating the laser wavelength by diode laser current modulation, using an external modulator to induce wavelength modulation,⁹ or using a reference level generated from a split beam.¹⁰ An alternative is to use a noncollimated laser output beam and sample the beam after it passes through a Fabry-Perot etalon at two different parts that have different optical paths in the etalon.^{11,12} By those methods, the laser system usually suffers from a modulated wavelength output, optical feedback, or frequency variation induced by angle drift of the Fabry-Perot etalon and laser beam. We present a differential two-resonance-peaks method, by which a laser beam is divided

into two beams with equal intensity. The two beams go through an etalon at an incident angle with an opposite sign to generate two frequency-adjacent resonant peaks respectively. The difference signal between the two resonance peaks is a nearly ideal dispersion-like error signal without laser wavelength modulation. The use of the differential two-resonance-peaks method is compared to a traditional single-resonance peak for laser stabilization. The result shows that the shift of a locking wavelength is smaller using the differential two-resonance-peaks method than the traditional single-peak method.

2 Laser Diode Stabilization Using the Difference Signal of Two Resonance Peaks

The resonance wavelength or frequency of a Fabry-Perot etalon depends on the length of the optical path along which the laser beam travels in the etalon. A peak can be selected for laser stabilization from a series of nearly equal frequency-spacing resonance peaks of the Fabry-Perot etalon. Changing the incident angle of the laser beam changes the resonance frequency of the peaks. If the laser output beam is divided into two beams *A* and *B*, and the two beams travel through the etalon with a small optical path length difference, then the resonance peaks of the two laser beams will be close to each other. Figure 1 shows signals in the selected wavelength scanning period. Signal *A* is obtained from beam *A*; signal *B* is from beam *B*; and signal *A-B* is obtained by subtracting signal *A* from signal *B*. The wavelengths of the resonance peaks will be shifted by adjusting the normal etalon that changes the incident angle of the laser beams. Three possible conditions among the two beams and the normal etalon are shown in Fig. 2. In the conditions shown in Figs. 2(a) and 2(b), the two laser beams are incident on the same side of the normal of the etalon. When the normal of the etalon is adjusted, all three peaks of signals *A*, *B*, and *A-B* move in the same direction,

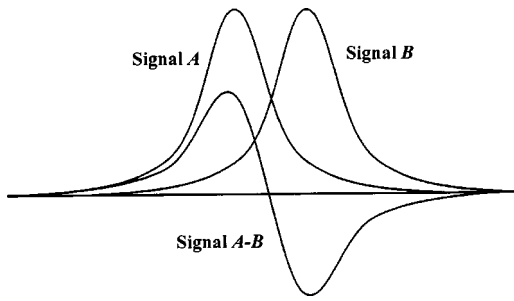

Fig. 1 Resonance peaks of signals *A* and *B* and their difference signal *A-B*.

as shown in Fig. 3. The optical path lengths of each beam in the etalon are either increased or reduced simultaneously in such a case. In the condition of Fig. 2(c), beams *A* and *B* enter the etalon from opposite sides of the normal of the etalon. When the normal is tilted, resonance peaks of signals *A* and *B* move closer or farther. The peak of signal *A-B* becomes wider or narrower, while the frequency of its zero crossing remains unchanged, as shown in Fig. 4. Locking a laser to the zero crossing of signal *A-B* is therefore insensitive to the drift of the angle between the normal of the etalon and the laser beam.

A simplified model is developed to compare the frequency drift of the peak of signal *A* or *B* with that of the zero crossing of signal *A-B* in the case depicted in Fig. 2(c). In Fig. 5, a laser beam, beam *A*, goes through an etalon at an incident angle θ_A . The resonance frequency f_A can be expressed as,

$$f_A = \frac{m \cdot c}{2d(n^2 - \sin^2 \theta_A)^{1/2}}, \tag{1}$$

where m is an integer, c is the light speed in vacuum, n is the refractive index of the material of the etalon, and d is the thickness of the etalon.

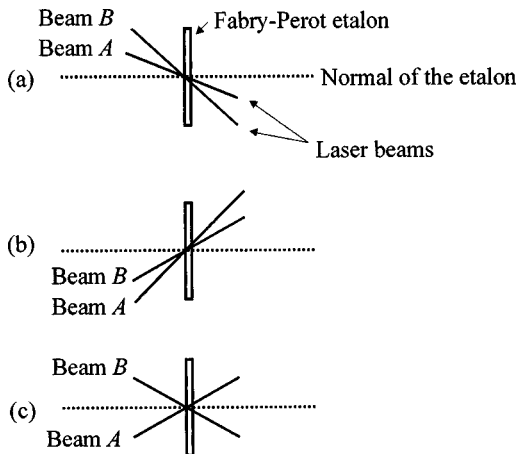

Fig. 2 Three cases of direction relation between the etalon's normal and the two incident laser beams. In (a) and (b), the laser beams enter the Fabry-Perot etalon from the same side of the normal, while in (c) the beams enter from opposite sides of the normal.

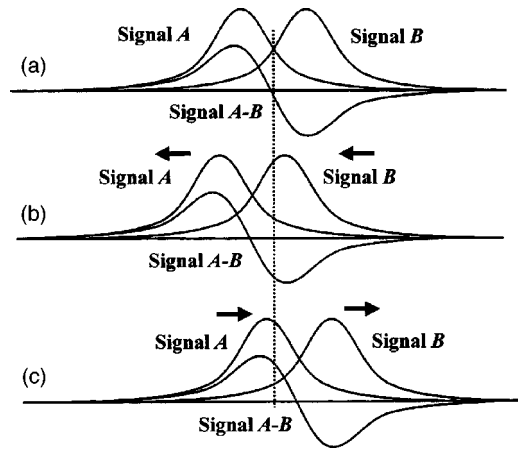

Fig. 3 The shift of resonance peak when the two laser beams are incident on one side of the Fabry-Perot etalon's normal. (a) is the resonance peaks before the normal of the Fabry-Perot etalon is tuned; (b) peak movement when the normal is tuned; and (c) peak movement when the normal is tuned in a different direction from that tuned in (b).

Tilting the normal of the etalon by an angle $\Delta\theta$ causes a resonance frequency shift Δf_A ,

$$\Delta f_A = \frac{m \cdot c}{2d} \left\{ \frac{1}{[n^2 - \sin^2(\theta_A + \Delta\theta)]^{1/2}} - \frac{1}{(n^2 - \sin^2 \theta_A)^{1/2}} \right\}. \tag{2}$$

When θ_A is small, and $\Delta\theta \ll \theta_A$,

$$\Delta f_A \approx \frac{m \cdot c \cdot \theta_A}{2n^3 \cdot d} \Delta\theta. \tag{3}$$

Derived from Eq. (3), the increment of the ratio $\Delta f_A / \Delta\theta$ is proportional to the increment of θ_A . In the case of the difference signal of two resonance peaks, the other laser beam, beam *B*, generated from the divided intensity of the same laser source of beam *A*, enters the etalon with an incident angle $-\theta_B$, as shown in Fig. 6. The θ_B is nearly

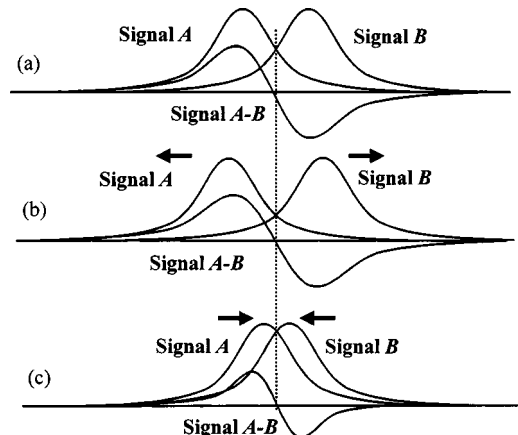

Fig. 4 The shift of resonance peaks when two laser beams are incident on different sides of the Fabry-Perot etalon's normal. Tuning situations in (a), (b), and (c) are similar to those in Fig. 3.

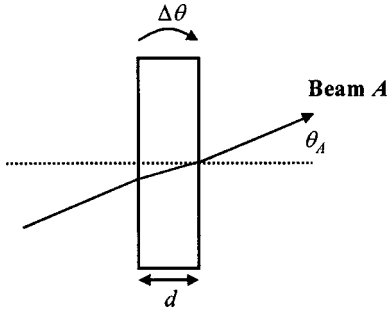

Fig. 5 Fabry-Perot etalon with one incident beam only.

equal to θ_A . The resonance frequency f_B of beam B is expressed as

$$f_B = \frac{m^*c}{2d[n^2 - \sin^2(-\theta_B)]^{1/2}} \quad (4)$$

If θ_A equals θ_B , and the resonance frequency f_B is the same as f_A , then peaks A and B are overlapped. Peaks A and B can be partially separated by adjusting the etalon at a small angle. If the two separated resonance signals are approximately equal intensities, we lock the laser frequency to the zero crossing of the differential signal of A and B . The frequency of the zero-crossing f_l is roughly the mean of f_A and f_B

$$f_l = \frac{1}{2} \left\{ \frac{m^*c}{2d(n^2 - \sin^2 \theta_A)^{1/2}} + \frac{m^*c}{2d[n^2 - \sin^2(-\theta_B)]^{1/2}} \right\} \quad (5)$$

When the normal of the etalon is rotated by $\Delta\theta$, the frequency shift Δf_l of the zero crossings is

$$\Delta f_l = \left(\frac{1}{2} \right) \left(\frac{m^*c}{2d} \right) \left\{ \frac{1}{[n^2 - \sin^2(\theta_A + \Delta\theta)]^{1/2}} + \frac{1}{[n^2 - \sin^2(-\theta_B + \Delta\theta)]^{1/2}} - \frac{1}{(n^2 - \sin^2 \theta_A)^{1/2}} - \frac{1}{[n^2 - \sin^2(-\theta_B)]^{1/2}} \right\} \quad (6)$$

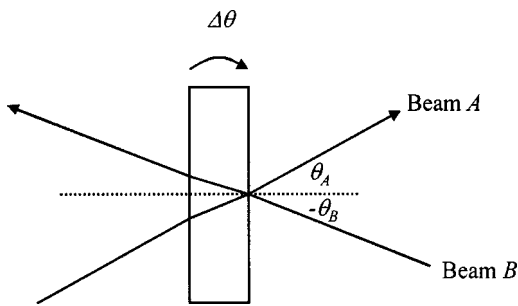

Fig. 6 Fabry-Perot etalon with two incident beams.

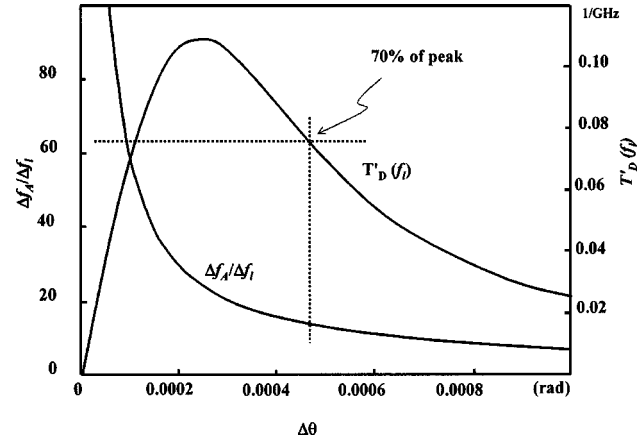

Fig. 7 The slope of the transmission $T'_D(f)$ and the ratio $\Delta f_A/\Delta f_l$ changed by $\Delta\theta$.

If θ_A and θ_B are small and $\Delta\theta \ll \theta_A, \theta_B$, then Eq. (6) can be simplified to

$$\Delta f_l \approx \frac{m^*c}{2n^3d} \frac{(\theta_A - \theta_B)}{2} \Delta\theta \quad (7)$$

From Eqs. (4) and (7), if θ_A is roughly equal to θ_B , then $\Delta f_l/\Delta\theta$ is smaller than $\Delta f_A/\Delta\theta$.

To estimate the limitation of $\Delta\theta$, we consider that the differential of the difference of transmissions of beam A and B through an etalon is:

$$T_D(f) = \frac{(1-R)^2}{(1-R)^2 + 4R^* \sin^2 \left[\frac{2\pi d(n^2 - \sin^2 \theta_A)^{1/2}}{c} f \right]} - \frac{(1-R)^2}{(1-R)^2 + 4R^* \sin^2 \left[\frac{2\pi d[n^2 - \sin^2(-\theta_B)]^{1/2}}{c} f \right]} \quad (8)$$

where R is the reflectivity of the mirrors of the etalon.

The slope of $T_D(f)$, $T'_D(f)$ can be expressed by $dT_D(f)/df$, which is an important parameter for laser wavelength stabilization. It decides the stability of the system. The locking point here is f_l . Using $T'_D(f_l)$ can estimate the suitable range of $\Delta\theta$. For example, if an air-space Fabry-Perot etalon with $R=60\%$ (finesse is 6.08), $d=22$ mm, $n=1$ (free spectral range is 6.8 GHz and peak width is 1.1 GHz), and $\theta_A = \theta_B = 0.0029$ rad. The change of $\Delta f_A/\Delta f_l$ and $T'_D(f_l)$ when the angles θ_A, θ_B are changed by $\pm\Delta\theta$ is shown in Fig. 7. The best locking point is located where the maximum $T'_D(f_l)$ occurs. At the point, $\Delta\theta$ is about 0.00024 rad, or $f_A - f_B$ is 0.63 GHz, and the $\Delta f_A/\Delta f_l$ is 25. If 70% of the maximum $T'_D(f_l)$ is the locking range we can accept, $\Delta\theta$ can change from 0.00011 to 0.00046 rad, and $f_A - f_B$ changes from 0.29 to 1.2 GHz. In this range, $\Delta f_A/\Delta f_l$ is between 52 and 11.

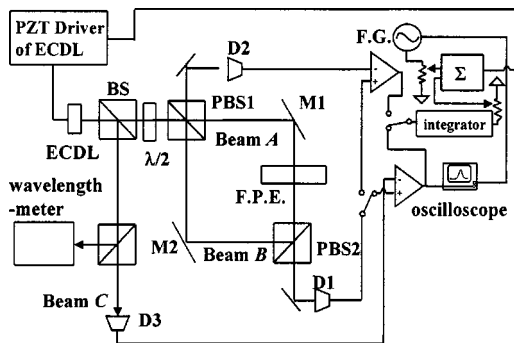

Fig. 8 Experimental setup for the differential two-resonance-peak method. ECDL: extended cavity diode laser; BS: beamsplitter; PBS1, PBS2: polarizing beamsplitter; D1, D2, D3: detector; FPE: Fabry-Perot etalon; and FG: function generator.

3 Experimental Setup

A schematic experimental setup for differential two-resonance-peak laser wavelength stabilization is shown in Fig. 8. An extended cavity diode laser (ECDL) with a wavelength of 657.460 nm, single longitudinal and transverse mode, and 6-mW maximum power is used for convenience. The laser beam is split into two parts, the transmitted light beam *A* and the reflected light beam *B*, by a polarizing beamsplitter PBS1. The intensities of both beams can be adjusted to be almost equal by rotating the optical axis of a half-wave plate, which was located before PBS1. Beam *A* is reflected by a mirror *M1*, then passes through the Fabry-Perot etalon and another polarizing beamsplitter PBS2, and detected by detector *D1*. The signal from *D1* is signal *A*. Beam *B* is reflected by mirror *M2* and the polarizing beamsplitter PBS2, and it then goes through the etalon. The through beam is reflected by *M1* and PBS1, and detected by detector *D2*. The signal from *D2* is signal *B*. Signal *B* is subtracted from signal *A* to yield their difference, signal *A-B*, which is the signal for stabilizing laser frequency. The difference signal is fed back to the PZT driver of the ECDL through an integrator with a 1.2-ms time constant. Laser frequency is modulated by the PZT with a saw-tooth signal. The resonance peaks are recorded by an oscilloscope. By adjusting the scan amplitude and the angles of *M1* and *M2*, only one resonance mode on the oscilloscope screen is selected for each laser beam. Then *M1* and *M2* are fixed after the alignment. Two resonance peaks, which correspond to the two beams and the difference signal, are observed on the oscilloscope simultaneously. To remove the frequency drift induced from thermal effect, an air-spaced Fabry-Perot etalon with a Zerodure spacer is used. The length of the spacer is 22 mm. The two mirrors are coated with antireflective coating on both outer sides and have 60% reflectivity on the inner sides. The air between two mirrors is evacuated to 0.4 Pa. The etalon is mounted on an adjustable mirror mount. A mirror is fixed roughly parallel to the etalon at the top of the mount, as shown in Fig. 9. The angle change of the mirror is almost the same as that of the etalon, and the angle of the mirror can be measured by an autocollimator. Adjusting mirrors *M1* and *M2*, the peaks shown on the oscilloscope move like those in Fig. 4, which ensures

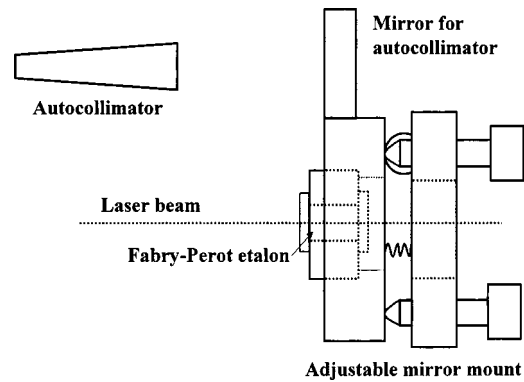

Fig. 9 Tilt angle of the Fabry-Perot measured by an autocollimator.

beams *A* and *B* enter the etalons from different sides of the normal of the etalon. We start the experiment when the resonance peaks of beams *A* and *B* are overlapped and the incident angle of each beam is opposite in sign. The incident angles θ_A and θ_B are both measured at about at 0.0029 rad. The autocollimator is reset to zero at this starting point. When the angle of the etalon is changed, read the angle change $\Delta\theta$ by the autocollimator. The shifting of peak *A* or *B* and the zero crossing of signal *A-B* on the oscilloscope is recorded. The oscilloscope is calibrated by using the free spectral range of the etalon. We compare the wavelength stability of the differential two-resonance-peak method with the traditional single-resonance-peak method. Another beam *C* that does not go through the etalon is sampled by detector *D3*. The differential of the single resonance signal *A* and the signal *C* is used as the error signal of the single-resonance-peak method. The stability of the laser is measured by a wavelength meter with a resolution of 0.0001 nm and $\pm 2 \times 10^{-7}$ uncertainty. To fit the limit of the wavelength meter, the short-term stability is designed to be 1.5×10^{-7} (0.0001 nm/657.460 nm), the resolution of the wavelength meter, or 0.0694-GHz frequency variation. From Fig. 7, in the 70% best locking region, the variation of the measurement of T_D should be less than 0.53%, where T_D is usually normalized to 1. That means only when the stability of the electronics is better than 0.53% we can use it to stabilize a laser to reach the designed specification.

4 Results

Figure 10 presents an example of the oscilloscope trace of the resonance signals and their difference signal. The widths of peaks *A* and *B* are about 1.1 GHz. The frequency separation is about 0.6 GHz, which is roughly at the best frequency locking point. No optical feedback was observed in this bench top system. Angles θ_A and θ_B differ slightly when peaks *A* and *B* do not overlap. The angle difference causes different walk-off losses on beams *A* and *B*. Hence, the peak widths of signals *A* and *B* are not exactly equal. However, this inequality is acceptable. It causes a small asymmetry in signal *A-B* only. The walk-off loss broadening also helps to decide if the peaks *A* and *B* are at the same mode. Changing the angle of etalon induces the peaks of signals *A* and *B* to move in opposite directions. In spite

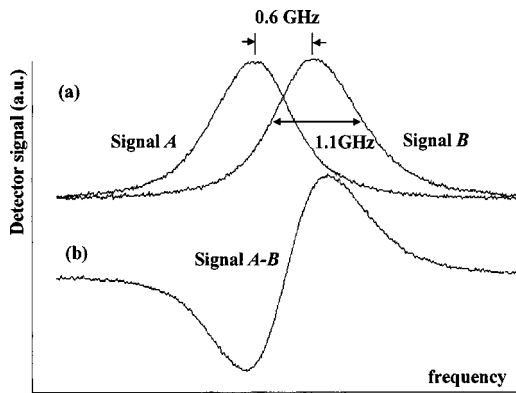

Fig. 10 Oscilloscope traces of resonance peaks: (a) signals *A* and *B* and (b) difference signal of two resonance peaks of beams *A* and *B*.

of the peak of signal *A-B* becoming wider or narrower, its zero crossing does not move significantly. We show the frequency shifting of the peaks of signals *A* and *B*, and the zero crossing of signal *A-B* in Fig. 11, as the normal of the etalon is tuned. We start the experiment from the point when $\theta_A = \theta_B = 0.0029$ rad. At this angle, the peak is not clearly broadened by the walk-off loss, and the reflected laser beams remain far enough from the laser diode to prevent an optical feedback problem. At the starting point, no *A-B* peak is observed. When $\Delta\theta$ is increased, signal *A-B* appears. As we depicted earlier, when the frequency difference is 0.6 GHz or $\Delta\theta = 0.00024$ rad, $T'_D(f_i)$ has an optimum slope; stabilizing the laser wavelength at this situation will get the best stability. The result of the stabilization is shown in Fig. 12(a). Similar results using the differential signal of signals *A* and *C* are shown in Fig. 12(b). Both the stabilization results in Fig. 12 start immediately when the alignment of the etalon is ready. Wavelength shift in Fig. 12(b) is about 0.0004 nm (0.28 GHz) in the first 3 h, while no considerable drift is observed in Fig. 12(a). The stability in Fig. 12(a) is about 3×10^{-7} in 72 h.

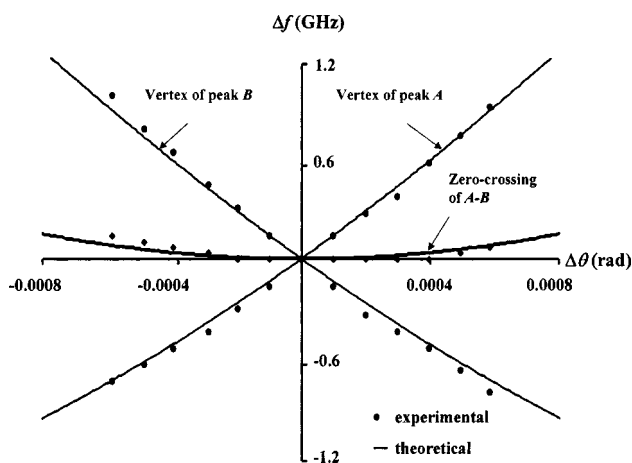

Fig. 11 Frequency shift of peaks *A*, *B*, and *A-B* when the Fabry-Perot etalon's normal is tuned.

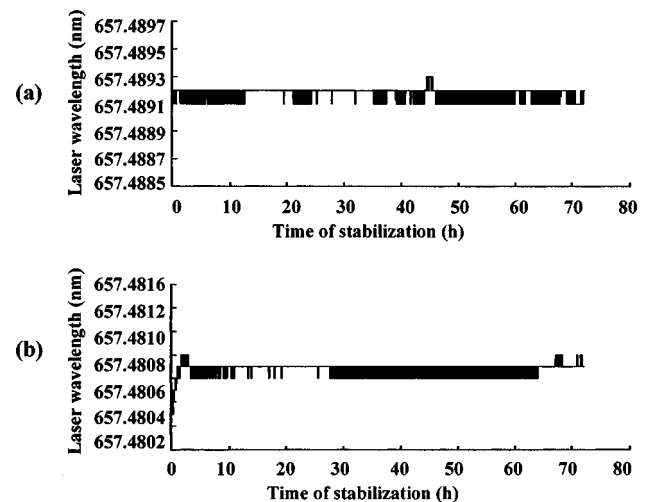

Fig. 12 Laser stabilization: (a) using the differential signal of two resonance peaks, and (b) using the differential signal of one resonance peak and a reference level.

5 Discussion

We present a method using the difference signal of two resonance peaks to stabilize a laser's frequency to a resonance of a Fabry-Perot etalon without modulating the laser frequency. Error signals with dispersion shapes are obtained. The zero-crossing frequency is found to be insensitive to the drift of the normal of the etalon under the condition that the two laser beams travel through the etalon with nearly equal incident angles to the etalon but with opposite signs. A simple experimental setup is introduced to implement the differential two-resonance-peak method. Other setups that divide the laser output into two beams with a small angular offset may also be appropriate for implementing this stabilization method. Considering that we have a nearly ideal shape error signal, no need for frequency modulation, and are insensitive to the drift of laser beams or the direction of the etalon's normal, the proposed differential two-resonance-peak method is a promising approach to build a compact stabilized laser.

Acknowledgments

This research was supported by the Center for Measurement Standards, Taiwan. The authors are grateful to Mr. Huay-Chung Liou, Miss Yu-Ping Lan, and Dr. Chien-Ming Wu for helpful discussions.

References

1. F. L. Hong, J. Ishikawa, Z. Y. Bi, J. Zhang, K. Seta, A. Onae, J. Yoda, and H. Matsumoto, "Portable I_2 -stabilized Nd:YAG laser for international comparisons," *IEEE Trans. Instrum. Meas.* **50**, 486–489 (2001).
2. T. J. Quinn, "Practical realization of the definition of the meter," *Metrologia* **36**, 211–244 (1999).
3. C. W. Oates, F. Bondu, R. W. Fox, and L. Hollberg, "A diode-laser optical frequency standard based on laser-cooled Ca atoms: sub-kilohertz spectroscopy by optical shelving detection," *Eur. Phys. J. D* **7**, 449–460 (1999).
4. P. Kersten, F. Mensing, U. Sterr, and F. Riehle, "A transportable optical calcium frequency standard," *Appl. Phys. B: Lasers Opt.* **68**, 27–38 (1999).
5. H. Talvitie, M. Merimaa, and E. Ikonen, "Frequency stabilization of a diode laser to Doppler-free spectrum of molecular iodine at 633 nm," *Opt. Commun.* **152**, 182–188 (1998).

6. J. M. Vaughan, *The Fabry-Perot Interferometer*, Adam Hilger, Philadelphia, PA (1989).
7. J. L. Hall, "Frequency-stabilized lasers: from the beginning toward the future," *Laser Phys.* **4**, 306–318 (1994).
8. K. Nakagawa, A. S. Shelkownikov, T. Katsuda, and M. Ohtsu, "Absolute frequency stability of a diode-laser-pumped Nd:YAG laser stabilized to a high-finesse optical cavity," *Appl. Opt.* **33**, 6383–6386 (1994).
9. H. S. Lee, C. H. Oh, S. H. Yang, and N. S. Chung, "Frequency stabilization of a directly modulated semiconductor laser," *Rev. Sci. Instrum.* **61**, 2478–2480 (1990).
10. M. W. Hamilton, "An introduction to stabilized lasers," *Contemp. Phys.* **30**, 21–23 (1989).
11. B. A. Villeneuve and H. B. Kim, "Wavelength monitoring and control assembly for WDM optical transmission systems," Patent No. EP 0818859 (1998).
12. D. A. Ackerman, D. J. Muehlner, and P. J. Anthony, "Wavelength stabilized laser," Patent No. US 6215801 (2001).



Mao-Sheng Huang graduated from National Central University of Taiwan in 1982 with a BS degree in physics, and received his MS degree in physics from National Tsing Hua University in 1989. Now he is pursuing his PhD degree at the Institute of Electro-Optical Engineering, the National Chiao Tung University of Taiwan. He is also a staff member at the Center for Measurement Standards, Taiwan. He has worked on the wavelength standards and frequency stabilization of lasers.



Mao-Hong Lu graduated from the Department of Physics at Fudan University in 1962. He then worked as a research staff member at Shanghai Institute of Physics and Technology, Chinese Academy of Sciences, from 1962 to 1970, and at the Shanghai Institute of Laser Technology from 1970 to 1980. He studied at the University of Arizona as a visiting scholar from 1980 to 1982. He is currently a professor at the Institute of Electro-Optical Engineering, National Chiao-Tung University.



Jow-Tsong Shy is a professor with the Department of Physics, National Tsing Hua University. He received his PhD degree in optical sciences from the University of Arizona in 1982. His research interests are laser spectroscopy, and atomic and molecular physics.