

In-service cable-monitoring technique for hybrid fiber/coaxial networks based on frequency domain analysis incorporated with optical time-domain reflectometer and fiber benders

Chien-Chung Lee

Chunghwa Telecom Labs
P.O. Box 6-1
Yang-Mei 326
Taoyuan, Taiwan
and

National Chiao-Tung University
Institute of Electro-Optical Engineering
Hsinchu, Taiwan
E-mail: chchl@ms.chttl.com.tw

Sien Chi

National Chiao-Tung University
Institute of Electro-Optical Engineering
Hsinchu, Taiwan

Abstract. An integrated on-line cable-monitoring technique for hybrid fiber/coaxial (HFC) networks is proposed and experimentally demonstrated. The in-service monitoring of fiber optic cable and coaxial cable is achieved simultaneously by an optical time-domain reflectometer (OTDR) and the frequency domain analysis (FDA) method, respectively, where the FDA results are encoded in the additional dummy fiber through digitally modulated fiber benders. This technique can be easily developed into an automated in-service surveillance system to provide real-time monitoring to enhance HFC network reliability. © 2000 Society of Photo-Optical Instrumentation Engineers. [S0091-3286(00)01002-3]

Subject terms: optical time-domain reflectometer; fiber fault location; supervisory technique; hybrid fiber/coaxial network.

Paper 980444 received Nov. 24, 1998; revised manuscript received June 16, 1999; accepted for publication July 23, 1999.

1 Introduction

Hybrid fiber/coaxial (HFC) networks for delivering subcarrier-multiplexed broadband video signals have become promising among cable television (CATV) architectures.¹⁻³ How to provide a practically centralized, integrated monitoring technique for supervising both fiber optic and coaxial cables at the headend is an important topic in these networks. However, it is not easy to do that because two totally different types of cables are operated in such networks. For fiber cable monitoring, utilization of the optical time-domain reflectometer (OTDR) through the wavelength-division-multiplexed (WDM) technique is an effective way for on-line supervision.^{4,5} For off-line coaxial cable testing, the electrical time-domain reflectometer (TDR) is the commonly used method. Although a nondestructive optical talk-set-service system combining an analog optical fiber amplitude modulator and an OTDR, used for fiber cable installation and maintenance, has been demonstrated recently,^{6,7} it is difficult to apply for monitoring of HFC networks. So far, the integrated, centralized monitoring technique of both cables for HFC networks has not yet been reported.

In this paper, an integrated, centralized HFC monitoring technique is proposed and experimentally demonstrated using frequency domain analysis (FDA) incorporated with an OTDR and fiber benders, whereas the FDA results for the coaxial cable network are encoded digitally by modulating the dummy fibers using homemade digital fiber benders. The monitoring status of both cables can be simultaneously observed in a single OTDR trace. Therefore, these two different cable media can be simultaneously monitored without extra electrical or optical return links.

2 Operation Principles

Figure 1 illustrates the operation principle of the technique. The on-line monitoring of fiber optic cables is achieved by operating the OTDR measurement via the multiplexer (WDM) at the transmitter (TX) site and the demultiplexer (WDDM) at the receiver (RX) site. The CATV TX commonly generates the amplitude modulation-vestigal sideband/quadrature amplitude modulated (AM-VSB/QAM) hybrid video signals in the 1550- or 1310-nm band, then the corresponding OTDR probe wavelength at 1310 or 1550 nm can be selected. On the other hand, on-line monitoring of coaxial cables is implemented by the frequency-sweeping method through a frequency-sweeping generator (FSG), an rf line spectrum analyzer (LSA), and the required rf diplexers for each coaxial cable link (see Fig. 1). The sweeping signal of 1 to 4.5 MHz, generated by the FSG, is launched into coaxial cable link, and the reflected swept signal is measured by the LSA. The sweeping frequency range is selected to avoid interference with the HFC upstream signals of 5 to 42 MHz. The high-pass (H) and low-pass (L) circuits of each diplexer provide transmissions for downstream video signals and two-way swept signals, respectively. The upper inset of Fig. 1 illustrates the frequency-swept impedance Z_i spectra of coaxial cable under (a) normal and (b) abnormal cases with open-circuit and (c) short-circuit faults. Coaxial cable is considered as the lossless transmission line,⁸ and the frequency-swept impedance Z_i of length l terminated in impedance Z_L can be described by

$$Z_i = R_0 \frac{Z_L + jR_0 \tan \beta l}{R_0 + jZ_L \tan \beta l}, \quad (1)$$

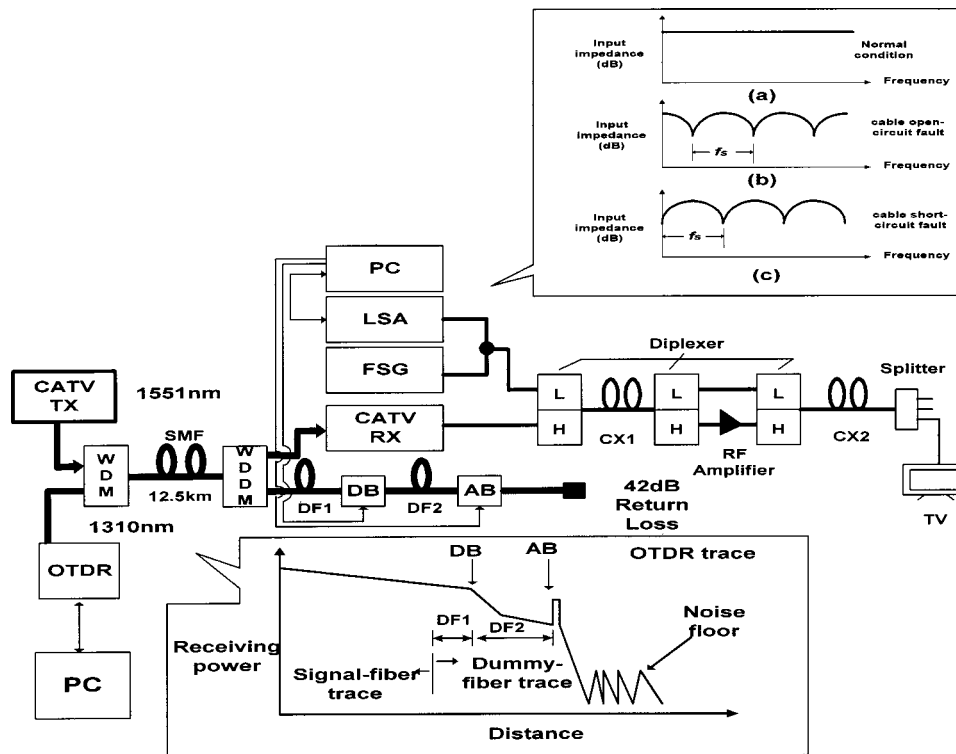

Fig. 1 Operation principle of the proposed integrated HFC monitoring technique.

where $\beta = 2\pi f\sqrt{LC}$ is propagation constant, $R_0 = (L/C)^{1/2}$ is the characteristic impedance of the coaxial cable, f is the sweeping frequency, and $L(C)$ is the coaxial cable inductance (capacitance) per unit length. For open-circuit termination ($Z_L \rightarrow \infty$), from Eq. (1), we have

$$Z_i(f) = -jR_0 \cot(2\pi fl\sqrt{LC}). \quad (2)$$

For short-circuit termination ($Z_L = 0$), Eq. (1) can be reduced to

$$Z_i(f) = jR_0 \tan(2\pi fl\sqrt{LC}). \quad (3)$$

Therefore, from Eqs. (2) and (3), we can determine the fault type and location by analyzing the frequency-swept impedance Z_i spectra. The fault position l of coaxial cable is given by

$$l = \frac{1}{2f_s\sqrt{LC}}, \quad (4)$$

where f_s is the frequency spacing between the valley points of Z_i . Note that if $f_s = 0$ the impedance matching of the cable link is good (i.e., no cable fault), otherwise a cable fault has occurred. Thus, both fault status and the location of the coaxial cable can be identified from the LSA trace by a personal computer (PC) at the RX site.

The centralized and integrated monitoring operation is realized by digitally encoding the LSA-measured results into additional dummy fibers, connected after the WDDM, through two kinds of fiber benders, the alarm bender (AB)

and the data bender (DB). Each fiber bender, constructed based on a mechanical bending mechanism, as shown in Fig. 2(a), is composed of an upper plate with two hooks, a reference rod, two sets of upper and lower plate stoppers, a solenoid coil, and a spring. The dummy single-mode fiber (SMF) with a primary coating diameter of $250 \mu\text{m}$ is placed horizontally above the reference rod. All fiber benders are controlled by the PC at the RX site via a digital-to-analog driving circuit. When the PC sends a bending on (bending off) signal, the upper plate will be pulled down (pushed up) by the current-driven solenoid coil. This pulling-down (pushing-up) force leads the hooks to bend (to relieve) the passed dummy fiber, thus a bending loss (no bending loss) occurs. The bending loss is determined by the distance X between the right and left stoppers, and the distance Y between the upper and lower stoppers, as shown in the inset of Fig. 2(a). We fabricated three fiber benders used in the experiments with $Y = 4 \text{ mm}$ and $X = 10, 9, 4 \text{ mm}$ to achieve an on-off bending loss of 0.25, 0.5, and 9 dB respectively, at 1310 nm.

In this system, the AB combined with a fiber connector with an appropriate return loss is used to produce a high bending loss of 9 dB, while a coaxial cable fault is occurring. Thus, an attenuated Fresnel reflection spike, representing the alarm of a cable fault, can be identified from the OTDR trace at the end of dummy fiber. In the meantime, the DB is modulated with a digital bit stream, which includes the message of fault types and fault position. At the TX site, the detected overall OTDR trace include two parts: one called the signal-fiber trace and the other called the dummy-fiber trace (see Fig. 1). The signal-fiber trace presents the monitored status of the optical signal transmission

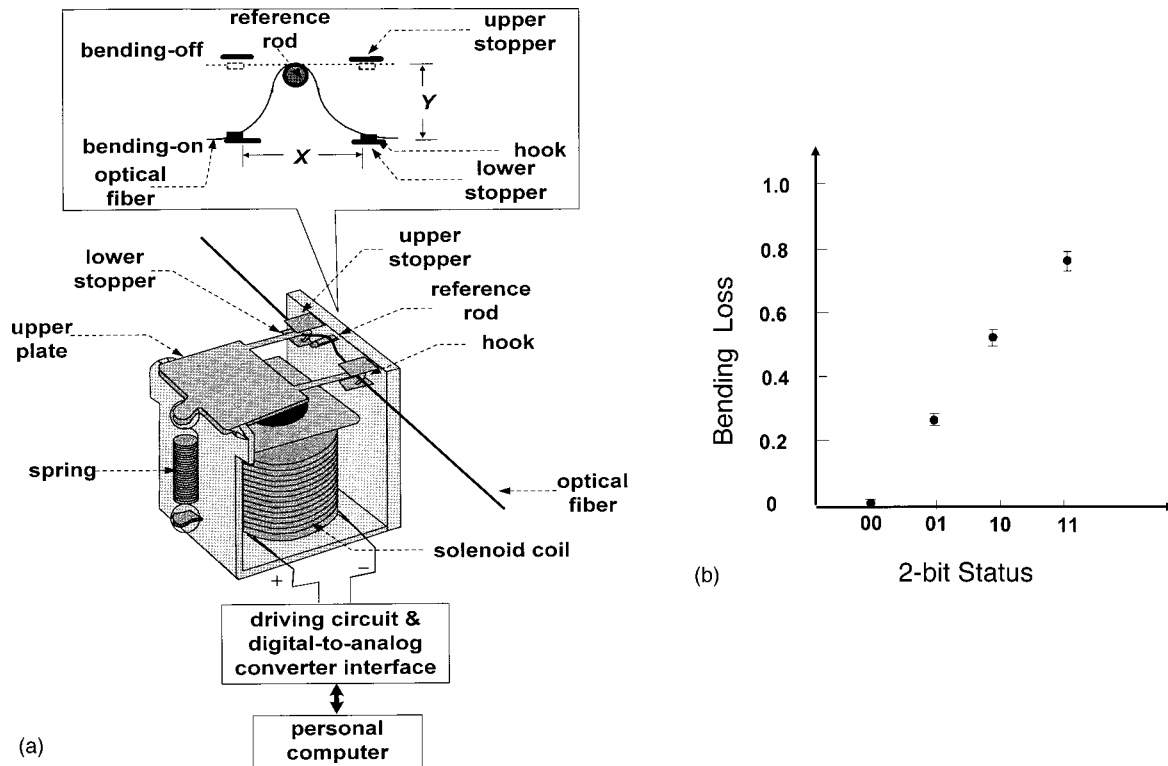

Fig. 2 (a) Schematic diagram of the fiber bender and (b) illustration of the bending-loss characteristics of a 2-bit composite DB.

fiber. The dummy-fiber trace represents the monitored status of the dummy fiber, which reveals the coaxial cable monitored messages. The dummy-fiber trace can be processed, and thus the frequency-swept status of the coaxial cable can be demodulated by using the PC at the TX site. In consequence, the centralized on-line monitoring of both cables can be achieved without the requirement for (1) a bidirectional line between PCs in the TX site and the RX site and (2) extra electrical or optical return links.

3 Experiments and Results

In the experiments, the HFC network is composed of a conventional SMF of 12.5 km, two 7C coaxial cables (CX1 and CX2 with 299 and 300 m lengths, respectively), and a unidirectional rf line amplifier with a 750-MHz bandwidth. The $1/\sqrt{LC}$ value of this 7C coaxial cable is about 2.72×10^8 m/s. An HP8663A synthesizer was used to provide the sweeping signals. Two dummy fibers, DF1 and DF2, each about 2.2 km, were used. The Anritsu MW0947B OTDR at 1310 nm is operated with a pulsewidth of 100 ns at a repetition rate of 1.5 kHz. The OTDR detected the Rayleigh backscattered signals of both the 12.5-km signal fiber and the 4.4-km dummy fibers, Figure 2(b) illustrates the bending loss of a 2-bit composite DB, which was formed by cascading a 0.5-dB DB followed with a 0.25-dB DB. Note that the maximum error of the total bending loss of this composite DB at any data-bit states is less than 0.03 dB, and hence the modulation repeatability is quite good. Because of restrict environmental conditions in field, however, more careful designs for these digital fiber benders are required in practice.

Figure 3(a) shows the OTDR trace for the HFC network under a normal coaxial cable condition and the corresponding frequency-swept spectrum. Note that a flat Z_i is observed due to good impedance matching. When a fiber cut occurred at 2.1 km, the OTDR trace in Fig. 3(b) responds exactly to this abnormal condition. When a coaxial cable fault happened with an open circuit at 299 m, Fig. 3(c) illustrates the OTDR trace and the corresponding swept spectrum. Note that an attenuated Fresnel reflection is observed in the OTDR trace because the AB is activated to alarm this fault. In the corresponding swept spectrum, the frequency spacing f_s between the 455-kHz valley points is measured by the LSA, then the fault position l_f of 299 m was calculated and obtained by the RX site PC. After recognizing the fault type and fault location, the RX site PC digitized this information into a bit stream of twelve bits of ‘‘10 10 01 01 01 10’’. The leftmost bit 1 represents an open-circuit fault and the other 11 bits represent the fault position at 299 m ($= 598 \times 0.5$ m). Here, the 0.5 m is a predefined encoding length. The PC then encoded this 12-bits sequence through an AB and a composite 2-bit DB into six sets of 3-bit data interleaved with five set of three 0 bits. Each bit period T is about 100 ms. The encoding, decoding, and readout processes are shown in Fig. 4. The first set of three bits of 011 is used to recognize the starting time of the data message, and every bit stream of 000 is used to separate the different data bits. The leftmost bit of each set of three data bits represents the AB in the on (or off) state when it is bit 1 (or 0). The data bit will be read out each

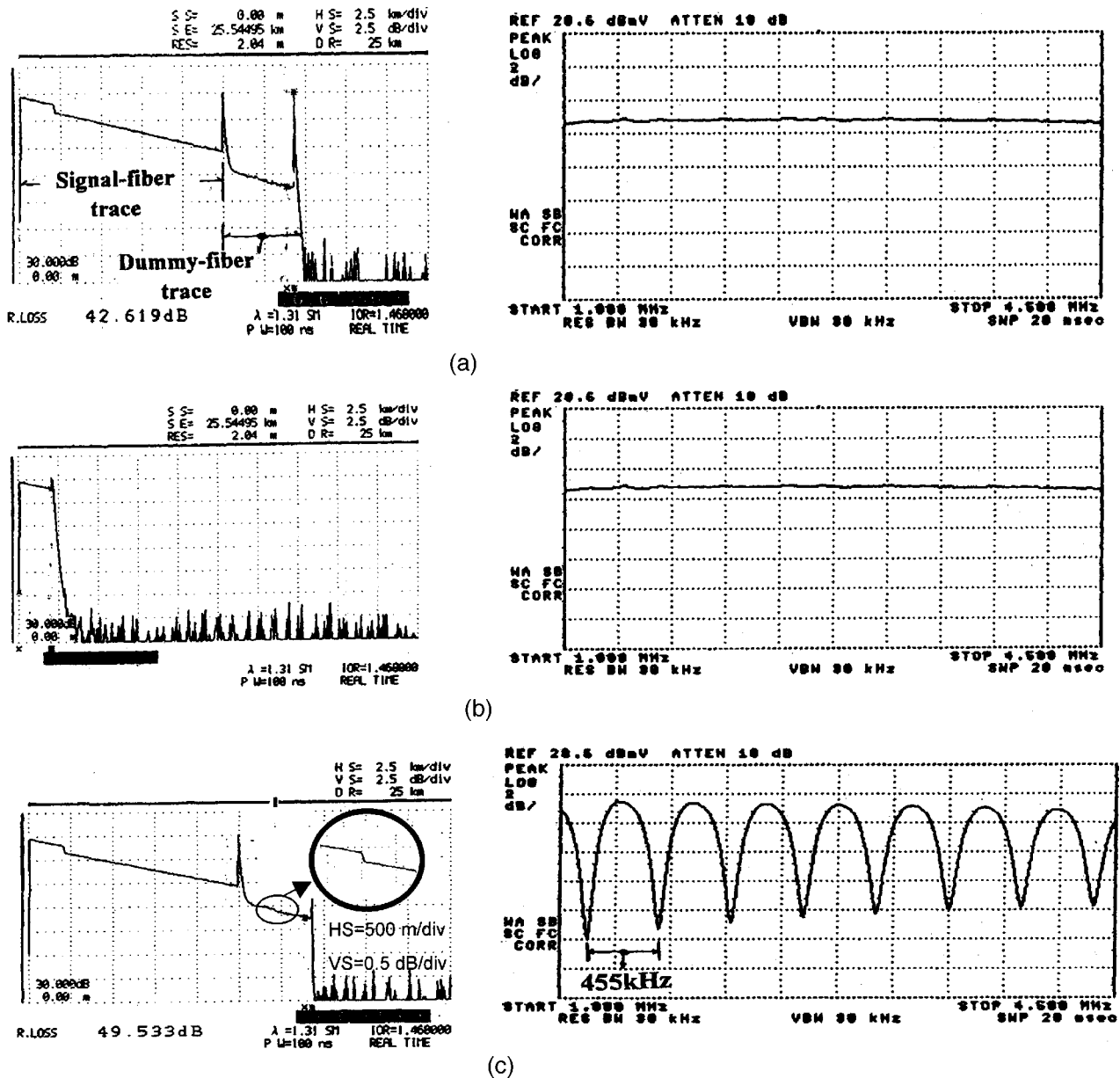

Fig. 3 OTDR trace and associated frequency-swept spectra of coaxial cable: (a) the normal OTDR trace with normal coaxial cable operation and the corresponding frequency-swept spectrum of normal coaxial cable, (b) the abnormal OTDR trace with a fiber cut at 2.1 km, and (c) the OTDR trace for normal fiber cable operation but with an open-circuit coaxial cable fault at 299 m and the corresponding frequency-swept spectrum.

time from the dummy-fiber trace processed by the PC at the TX site, when such an AB is 1. Finally, the coaxial cable with an open-circuit fault at 299 m was identified. Consequently, the experimental results confirm the feasibility of proposed technique.

A single DB with a 4-bit level can provide a 2-bit encoding with about 20 bit/s transmission rate when the OTDR operated at the 1.5-kHz repetition rate. The utilization of more DBs with dummy fibers can extend the bit number and thus speed up analysis of the cable fault. For instance, by cascading four such DBs with five segments of dummy fibers, a transmission rate of 80 bit/s can be

achieved. For proper operation of the encoded OTDR, the shortest dummy fiber length per segment should be larger than twice the used OTDR event dead zone. The supervised signal-fiber length that can be reached is about 35 km for this OTDR with a dynamic range (DR) of about 15 dB using a probe pulsewidth of 100 ns (an event dead zone of about 50 m). The larger the pulsewidth, the larger the DR, and thus a longer supervised fiber link; however, the event resolution worsenes. Furthermore, a supervised coaxial cable length of 1800 m for conventional 7C cable can be reached because of the 42-dB effective detection DR of the SFG and LSA we used.

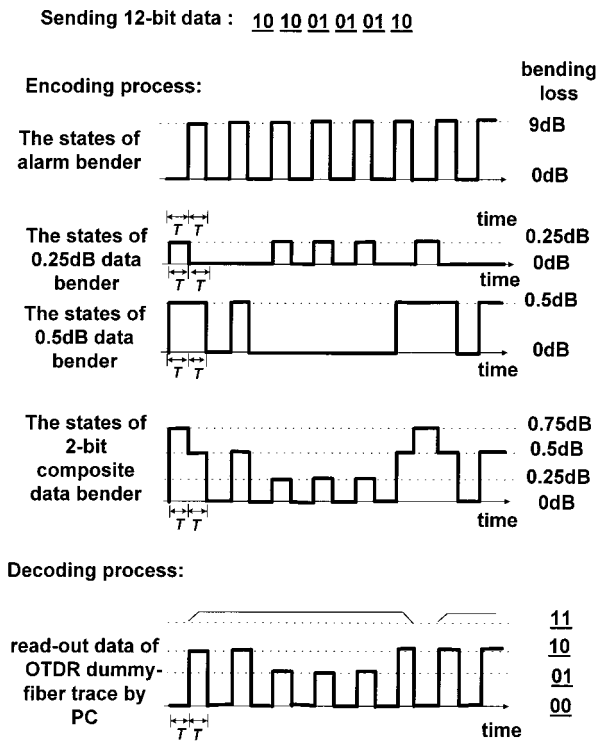

Fig. 4 Encoding, decoding, and readout timing diagram of the data bit associated with the information of a coaxial cable fault.

4 Conclusions

We successfully demonstrated an integrated cable-monitoring technique for HFC networks using the FDA method incorporated with an OTDR and fiber benders. The FDA results are encoded in the dummy fibers through alarm and data fiber benders. The monitoring status of both cables can be simultaneously observed and identified from a single OTDR trace without the necessity for additional maintenance networks. This technique can be easily developed into an automated in-service surveillance system to provide real-time monitoring to enhance HFC network reliability.

References

1. R. Olshansky, V. A. Lanzisera, S.-F. Su, R. Gross, A. M. Forcucci, and A. Hugh Oakes, "Subcarrier multiplexed broad-band service network: a flexible platform for broad-band subscriber services," *J. Lightwave Technol.* **11**(1), 60–69 (1993).
2. X. Lu, G. E. Bodeep, and T. E. Darcie, "Broad-band AM-VSB/64 QAM cable TV system over hybrid fiber/coax network," *IEEE Photonics Technol. Lett.* **7**, 330–332 (1995).
3. H. Dai, S. Ovadia, and C. Lin, "Hybrid AM-VSB/M-QAM multi-channel video transmission over 120 km of standard single-mode fiber

- with cascaded erbium-doped fiber amplifiers," *IEEE Photonics Technol. Lett.* **8**(12), 1713–1715 (1996).
4. S. I. Furukawa, Y. Koyamada, and H. Izumita, "Fault location technique for in-service branched optical fiber networks," *IEEE Photonics Technol. Lett.* **2**, 766–768 (1990).
5. C. C. Lee, K. Y. Chen, F. Y. Tsai, K. H. Lai, T. J. Liaw, and B. H. Wann, "Optical fiber monitoring systems for passive optical networks," in *Proc. 1994 Int. Wire and Cable Symp. (IWCS'94)*, pp. 494–498, Atlanta, GA (Nov. 1994).
6. Y. Azuma, Y. Shibata, S. Tamura, and N. Kuwaki, "Non-destructive optical fiber amplitude modulator for optical talk system over 80 km," in *Proc. 1992 Int. Wire and Cable Symp. (IWCS'92)*, pp. 97–103, Atlanta, GA (Nov. 1992).
7. Y. Azuma, H. Izumita, and K. Yoshida, "A non-destructive optical talk system using Fresnel-reflection light signals," in *Proc. 1995 Int. Wire and Cable Symp. (IWCS'95)*, pp. 372–379, Reno, NV (Nov. 1995).
8. D. K. Cheng, *Field and Wave Electromagnetics*, pp. 379–399, Addison-Wesley, New York (1983).

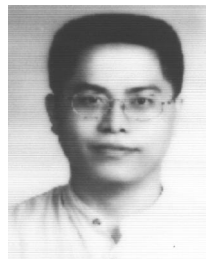

Chien-Chung Lee received the MSc degree in electro-optical engineering from the National Central University in 1991 in Taiwan. Also in 1991, he joined the Telecommunication Laboratories, Ministry of Transportation and Communications, in Taiwan (now renamed as Chunghwa Telecom Labs). Since that time he has been working on fiber in the loop technologies, including fiber measurement and optical CATV transmission. His current research interests include in-service surveillance technologies for optical networks, and applications of EDFA for WDM transmission and analog video HFC networks. He is now working toward his PhD degree.

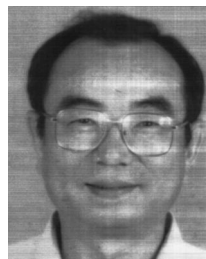

Sien Chi received his BSEE degree from the National Taiwan University and his MSEE degree from the National Chiao-Tung University, Taiwan, in 1959 and 1961, respectively. He received his PhD in electrophysics from the Polytechnic Institute of Brooklyn, New York, in 1971, and he joined the faculty of National Chiao-Tung University, where he is currently a professor of electro-optical engineering and vice-president of the university. From 1972 to 1973 he chaired the Department of Electrophysics; from 1973 to 1977 he directed the Institute of Electronics; from 1977 to 1978 he was a resident visitor at Bell Laboratories, Holmdel, New Jersey; from 1985 to 1988 he was the principal advisor with the Hua-Eng Wires and Cables Company, the first manufacturer of fibers and fiber cables in Taiwan, developing fiber making and cabling technology; and from 1988 to 1990 directed the Institute of Electro-Optical Engineering. He was the symposium chair of the International Symposium of Optoelectronics in Computers, Communications and Control in 1992, which was co-organized by National Chiao-Tung University and SPIE. From 1993 to 1996 he received the Distinguished Research Award sponsored by the National Science Council, Taiwan. Since 1996 he has been the chair professor of the Foundation for the Advancement of Outstanding Scholarship. His research interests are optical fiber communications, optical solitons and optical fiber amplifiers. He is a fellow of the Optical Society of America and the Photonics Society of Chinese-Americans.