

Quasi-Universal Switch Matrices for FPD Design

Guang-Ming Wu and Yao-Wen Chang, *Member, IEEE*

Abstract—An FPD switch module M with w terminals on each side is said to be *universal* if every set of nets satisfying the dimension constraint (i.e., the number of nets on each side of M is at most w) is simultaneously routable through M [8]. Chang et al. have identified a class of universal switch *blocks* in [8]. In this paper, we consider the design and routing problems for another popular model of switch modules called *switch matrices*. Unlike switch *blocks*, we prove that there exist no universal switch *matrices*. Nevertheless, we present *quasi-universal* switch matrices which have the maximum possible routing capacities among all switch matrices of the same size and show that their routing capacities converge to those of universal switch blocks. Each of the quasi-universal switch matrices of size w has a total of only $14w - 20$ ($14w - 21$) switches if w is even (odd), $w > 1$, compared to a fully populated one which has $3w^2 - 2w$ switches. We prove that no switch matrix with less than $14w - 20$ ($14w - 21$) switches can be quasi-universal. Experimental results demonstrate that the quasi-universal switch matrices improve routability at the chip level.

Index Terms—Analysis, architecture, design, digital, gate array, programmable logic array.

1 INTRODUCTION

FIELD-PROGRAMMABLE DEVICES (FPDs) refer to any digital, user-configurable integrated circuits used to implement logic functions. Due to their short production time and low prototyping cost, FPDs have become a very popular alternative to realizing logic designs. Fig. 1 shows the architectures of major commercially available FPDs. As illustrated in Fig. 1a and Fig. 1b, a *Field-Programmable Gate Array* (FPGA) consists of an array of logic modules that can be connected by general routing resources. The logic modules contain combinational and sequential circuits that implement logic functions. The routing resources consist of horizontal and vertical channels and their intersection areas. An intersection area of a horizontal and a vertical channel is referred to as a *switch module*. A net can change its routing direction via a switch module; this requires using at least one programmable switch inside the switch module. A large circuit that cannot be accommodated into a single FPGA is divided into several parts; each part is realized by an FPGA and these FPGAs are then interconnected by a *Field-Programmable Interconnect Chip* (FPIC) (see Fig. 1c). In a *Complex Programmable Logic Device* (CPLD), logic modules are surrounded by *continuous* horizontal and vertical routing tracks (see Fig. 1d). Similar to FPGAs, an intersection area of a horizontal and a vertical channels in an FPIC or a CPLD is also referred to as a switch module.

Recent works by [5], [17] have shown that the feasibility of FPGA design is constrained more by routing resources than by logic resources and, often, routing delays, rather than logic-module delays, dominate the performance of FPGAs. Therefore, it is desirable to facilitate routing in the design of FPGAs and FPICs. Switch modules are the most

important component of the routing resources in FPDs. Studies by [6], [8], [15] have shown that the higher the routability of the switch modules, the smaller the track count needed to achieve 100 percent routing completion. Hence, increasing the routability of a switch module also improves the area performance of a router. Therefore, it is of significant importance to consider switch-module design. In current technology, FPD programmable switches usually consume a large amount of area. Due to the area constraint, the number of switches that can be placed in a switch module is usually limited, implying limited routability. Therefore, there is a basic trade-off between routability and area for switch-module architectures.

There are two types of switch modules in commercially available FPDs, *switch matrices* and *switch blocks*. (See Fig. 2 for their models.) The effects of switch-module architectures on routing for the symmetric-array-based FPGAs were first studied experimentally by Rose and Brown [15]. A theoretical study of flexibility and routability was later presented based on a stochastic model [6]. The primary conclusion in both of the studies in [6], [15] is that high pin-to-track connectivity together with relatively low switch-module connectivity is a better solution to the routability and area trade-off. Therefore, the architecture of a switch module is of particular importance, due to a relatively small switch population in a switch module. Chang et al. [8] proposed a class of high-routability switch blocks and analyzed three types of well-known switch blocks; they showed theoretically and experimentally that switch blocks with higher routability usually lead to better area performance, which confirms the findings by [6], [15].

In this paper, we focus on switch *matrices*. Not much work has been reported on switch-matrix design. Zhu et al. in [19] first explored the feasibility conditions for switch matrices and presented a design heuristic based on a stochastic approach. Chang et al. in [7] applied a network-flow based heuristic for switch-module design. Sun et al. in

• The authors are with the Department of Computer and Information Science, National Chiao Tung University, Hsinchu 300, Taiwan.
E-mail: ywchang@cis.nctu.edu.tw.

For information on obtaining reprints of this article, please send e-mail to: tc@computer.org, and reference IEEECS Log Number 108469.

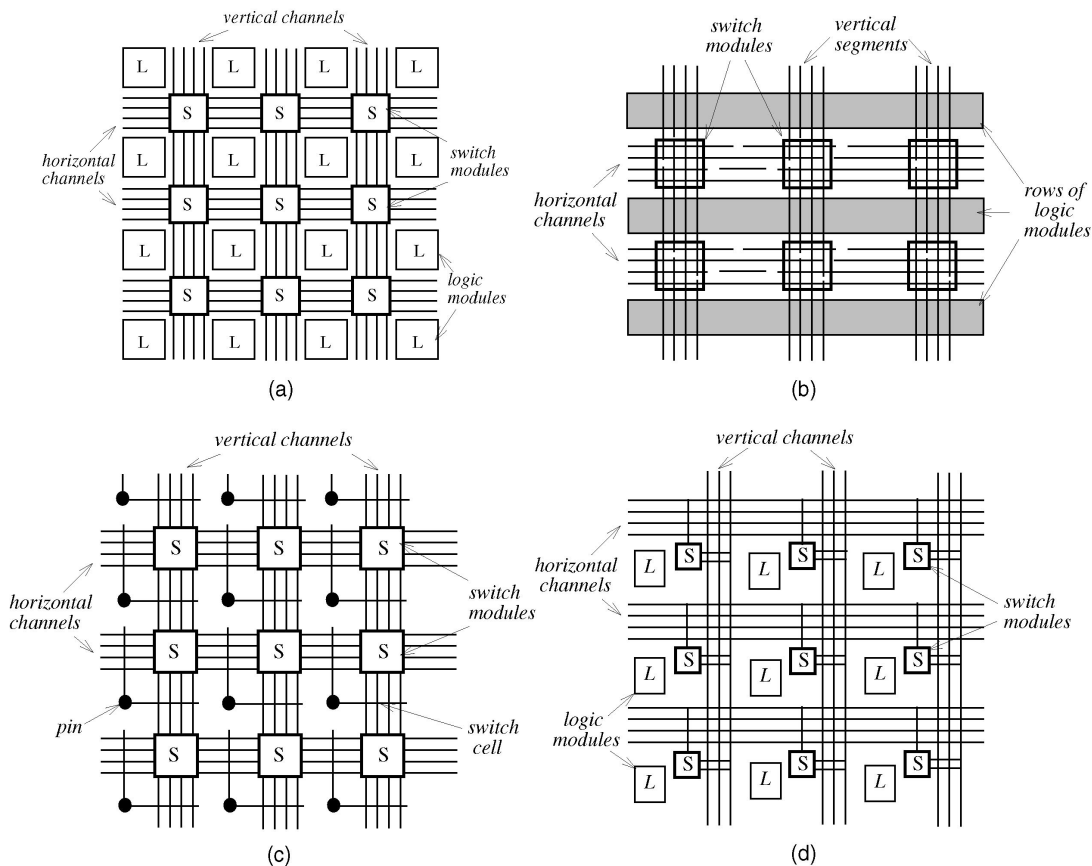

Fig. 1. Major FPD architectures. (a) The symmetric-array FPGA model. (b) The row-based FPGA model. (c) The FPIC model. (d) The CPLD model.

[16] studied the effects of using the two switch-module architectures—switch matrices and switch blocks—on routing. Based on the study in [16], an FPGA/FPIC with switch matrices in general needs fewer switches but more routing tracks for routing completion than that with switch blocks. This work shows the trade-offs in using the two types of switch modules.

In this paper, we consider the design and routing problems for *universal* switch matrices. An FPD switch module M with w terminals on each side is said to be *universal* if every set of nets satisfying the dimension constraint (i.e., the number of nets on each side of M is at most w) is simultaneously routable through M [8]. We prove that there exist no universal switch matrices. Nevertheless, we present *quasi-universal* switch matrices which

have the maximum possible routing capacities among all switch matrices of the same size and show that their routing capacities converge to those of universal switch modules. Each of the quasi-universal switch matrices of size w has a total of only $14w - 20$ ($14w - 21$) switches if w is even (odd), $w > 1$, compared to a fully populated one which has $3w^2 - 2w$ switches. We prove that no switch matrix with less than $14w - 20$ ($14w - 21$) switches can be quasi-universal. Experimental results demonstrate that the quasi-universal switch matrices improve routability at the chip level.

The rest of the paper is organized as follows: Section 2 gives the preliminaries for our problem. Section 3 explores the feasibility conditions of switch matrices. Section 4 presents the quasi-universal switch matrices. Section 5 gives an example graph modeling for detailed routing. Finally, experimental results are reported in Section 6.

2 PRELIMINARIES

A *switch matrix* consists of a grid of w horizontal and w vertical tracks. We represent a switch matrix by M_w (or M if w is not of concern). There are two types of switches in a switch matrix, *crossing switches* and *separating switches*. (See Fig. 2a.) If a crossing switch at the intersection of a horizontal and a vertical tracks is "ON," the two tracks are connected; if it is "OFF," the tracks are not connected and are thus electrically noninteracting. If a separating switch on a track is "OFF," the track is split into two electrically noninteracting routing segments so that the

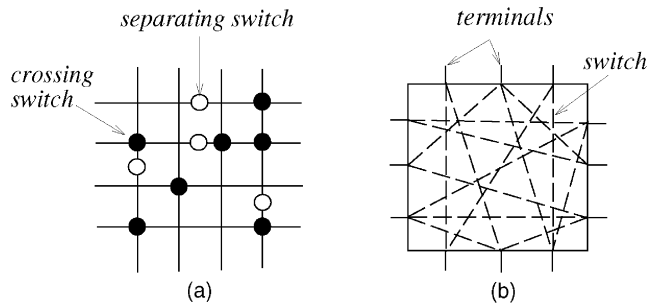

Fig. 2. Switch-module models. (a) Switch matrix. (b) Switch block.

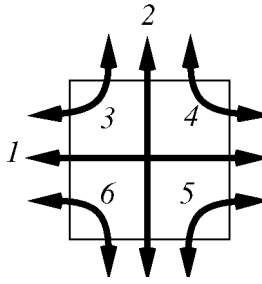

Fig. 3. Six types of connections.

terminals on opposite sides can be used independently; if it is “ON,” the track becomes a single electrical track. In Fig. 2a, the crossing switches are represented by solid circles and the separating switches by hollow circles. Switch matrices are used in various symmetric-array FPGAs [4], [11], row-based FPGAs [1], [9], FPICs [3], and CPLDs [2].

A *connection* is an electrical path between two terminals on different sides of a switch module. Connections can be of six types, each of which is characterized by two sides of a module, as shown in Fig. 3. For example, type-6 connections connect terminals on the left and the bottom sides of a module. Type-1 and type-2 connections are *straight connections*, whereas the others are *bent connections*.

A *routing requirement vector* (RRV) \vec{n} is a six-tuple (n_1, n_2, \dots, n_6) , where n_i is the number of type- i connections required to be routed through a switch module, $0 \leq n_i \leq w$, $i = 1, 2, \dots, 6$. An RRV \vec{n} is said to be *routable* on a switch module M , denoted by $\vec{n} \propto M$, if there exists a routing for \vec{n} on M . For example, the RRV $(0, 1, 0, 1, 1, 1)$ is routable on the switch matrix shown in Fig. 4 by programming the switches 1, 2, 3, and 7 to be ON, and a routing solution is illustrated by the thick lines; on the other hand, the RRV $(2, 2, 1, 0, 1, 0)$ is not routable on the switch matrix.

An RRV $\vec{m} = (m_1, m_2, \dots, m_6)$ is *dominated* by another RRV $\vec{n} = (n_1, n_2, \dots, n_6)$, denoted by $\vec{m} \leq \vec{n}$, if and only if $m_i \leq n_i, \forall i, 1 \leq i \leq 6$. Any RRV \vec{m} is routable on a switch matrix M if there exists an RRV \vec{n} that is routable on M and $\vec{m} \leq \vec{n}$; i.e., $\vec{n} \propto M \wedge \vec{m} \leq \vec{n} \implies \vec{m} \propto M$. An RRV \vec{n} is called *maximally routable* on a switch module M if $\vec{n} \propto M$ and no additional nets can be routed through M ; in other words, \vec{n} is maximally routable if \vec{n} is not dominated by any other routable RRV on M .

The *routing capacity* of a switch module M is referred to as the number of distinct routable RRVs on M ; that is, the routing capacity of M is the cardinality $|\{\vec{n} | \vec{n} \propto M\}|$. The *universal switch module* (USM for short) is defined in [8] as follows:

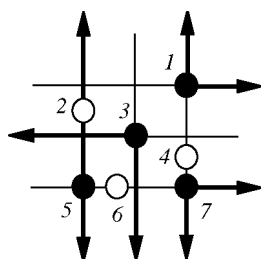

Fig. 4. Example of a switch-matrix routing.

Definition 1 [8]. A switch module M_w is called *universal* if the following set of inequalities is the necessary and sufficient conditions for an RRV $\vec{n} = (n_1, n_2, \dots, n_6)$ to be routable on M :

$$n_1 + n_3 + n_6 \leq w \tag{1}$$

$$n_2 + n_3 + n_4 \leq w \tag{2}$$

$$n_1 + n_4 + n_5 \leq w \tag{3}$$

$$n_2 + n_5 + n_6 \leq w. \tag{4}$$

Note that the number of nets routed through each side of M cannot exceed w ; this dimension constraint is characterized by the preceding four inequalities, one for each side. Therefore, a USM has the maximum routing capacity, and it is desirable to find such a universal switch *matrix*, if any. In this paper, we design a class of switch matrices with best possible routing capacities and give the qualitative and quantitative analyses for the matrices.

3 FEASIBILITY CONDITIONS

In this section, we explore the feasibility conditions of switch matrices.

Lemma 1. An RRV \vec{n} is routable on a switch matrix M_w ($\vec{n} \propto M_w$) only if $\vec{n} = (w, w, 0, 0, 0, 0)$ or the following set of inequalities is satisfied:

$$n_1 + n_3 + n_6 \leq w \tag{5}$$

$$n_2 + n_3 + n_4 \leq w \tag{6}$$

$$n_1 + n_4 + n_5 \leq w \tag{7}$$

$$n_2 + n_5 + n_6 \leq w \tag{8}$$

$$n_1 + n_2 + \max\{n_3 + n_5, n_4 + n_6\} \leq 2w - 1. \tag{9}$$

Proof. The proof is inspired by the work in [19]. Obviously, $(w, w, 0, 0, 0, 0) \propto M_w$. It is trivial that (5)-(8) are necessary conditions for an RRV \vec{n} to be routable on M_w because nets routed through each side of M_w cannot exceed w . We show that (9) is also a necessary condition for $\vec{n} \propto M$. Consider the RRV $\vec{n} = (0, 0, w, 0, w - 1, 0)$. We show that \vec{n} is maximally routable. Clearly, any increment in $n_1, n_2, n_3, n_4,$ or n_6 would result in violation of the necessary conditions (5) or (6). To verify that it is also impossible to increase n_5 , see Fig. 5a. Since $n_3 = w$, track t_1 , on the left side of the switch matrix in Fig. 5a, must be used to route a type-3 net, say net x . Net x must turn upward somewhere on the track t_1 , and this will prevent one track on the bottom side of the switch matrix from routing type-5 nets. For example, if net x turns upward at the intersection of track t_1 and track t_3 , then track t_3 cannot be used to route type-5 nets. Therefore, $n_5 = w - 1$ cannot be increased and \vec{n} is maximally routable. Consider the RRV $\vec{n} = (i, i, w - i, 0, w - i - 1, 0)$, for

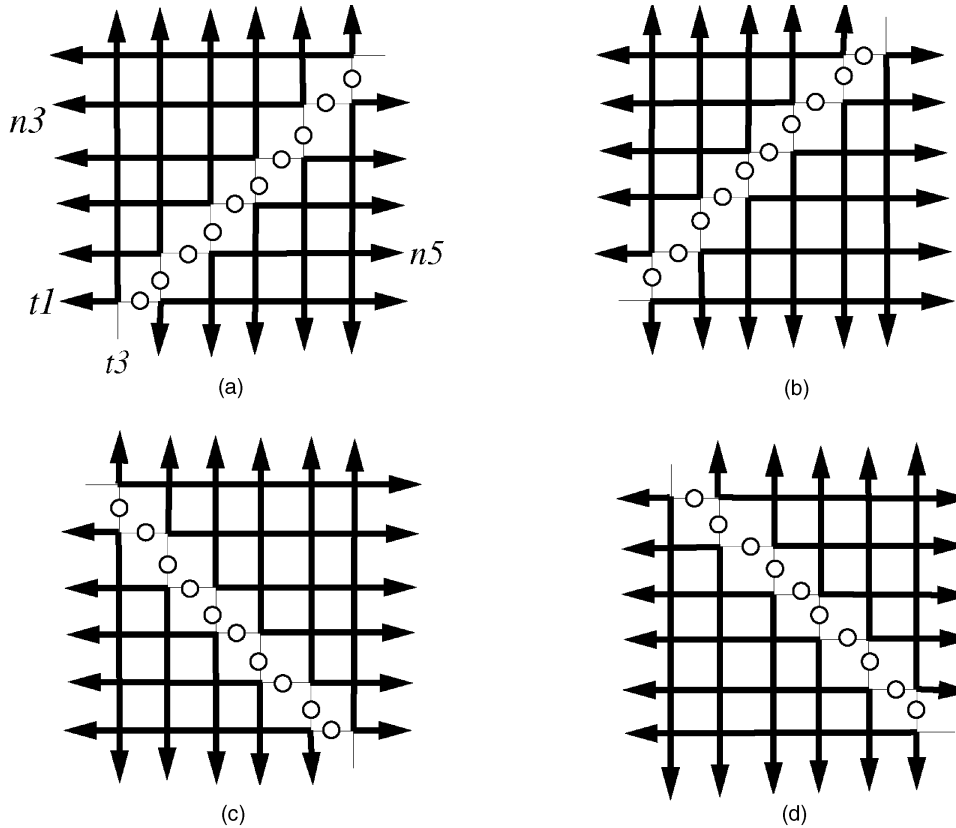

Fig. 5. Routing configurations for four RRVs. (a) $\vec{n}_1 = (0, 0, 6, 0, 5, 0)$. (b) $\vec{n}_2 = (0, 0, 5, 0, 6, 0)$. (c) $\vec{n}_3 = (0, 0, 0, 6, 0, 5)$. (d) $\vec{n}_4 = (0, 0, 0, 5, 0, 6)$.

$1 \leq i \leq w - 1$. Since $n_1 = n_2 = i$, there are i horizontal tracks and i vertical tracks that must be used to route n_1 type-1 and n_2 type-2 nets. Further, these tracks cannot be used to route any other type of nets. Therefore, routing RRV \vec{n} on M_w can be reduced to routing \vec{n}' on M' of size $w - i$ by prerouting n_1 type-1 and n_2 type-2 nets, where $\vec{n}' = (0, 0, w - i, 0, w - i - 1, 0)$. For the case where $n_1 \neq n_2$, since routing a bent net (a type-3, -4, -5, or -6 net) requiring using a horizontal and a vertical tracks, the combined number of type-3 and -5 (type-4 and -6) is limited by $i = \max\{n_1, n_2\}$. Hence, for the case where $n_1 \neq n_2$, routing RRV \vec{n} on M_w can also be reduced to routing \vec{n}' on M' of size $w - i$ by prerouting n_1 type-1 and n_2 type-2 nets, where $\vec{n}' = (0, 0, w - i, 0, w - i - 1, 0)$ and $i = \max\{n_1, n_2\}$. Based on the preceding observation, \vec{n}' is maximally routable on M' , and so is \vec{n} on M_w . Similarly, the RRVs $(i, i, 0, w - i, 0, w - i - 1)$, $(i, i, w - i - 1, 0, w - i, 0)$, and $(i, i, 0, w - i - 1, 0, w - i)$ are also maximally routable on M_w , $0 \leq i \leq w - 1$. Thus, (9) is a necessary condition for an RRV to be routable on M_w . \square

By Lemma 1, we have the following negative result.

Theorem 1. *There exists no universal switch matrix.*

Also, by Lemma 1, an RRV is simply unroutable on any switch matrix if the RRV fails to satisfy (5)-(9). We call an RRV *nontrivial* if it satisfies (5)-(9); otherwise, it is *trivial* (trivially unroutable). A switch matrix M is said to be *quasi-*

universal if all nontrivial RRVs are routable on M . We give the formal definition of a *quasi-universal switch matrix* (Q-USM for short) as follows:

Definition 2. *A switch matrix M_w is called quasi-universal if (5)-(9) are the necessary and sufficient conditions for an RRV $\vec{n} = (n_1, n_2, \dots, n_6)$ to be routable on M_w .*

Since (5)-(9) are the most fundamental routing constraints, a Q-USM has the maximum routing capacity among all switch matrices. It is thus of particular importance to find such class of switch matrices.

4 QUASI-UNIVERSAL SWITCH MATRICES (Q-USM)

In this section, we present procedures for constructing the Q-USM and give quantitative analyses for the matrices.

4.1 Procedures for Q-USM Design

Fig. 5a, Fig. 5b, Fig. 5c, and Fig. 5d show configurations for routing $\vec{n}_1 = (0, 0, 6, 0, 5, 0)$, $\vec{n}_2 = (0, 0, 5, 0, 6, 0)$, $\vec{n}_3 = (0, 0, 0, 6, 0, 5)$, and $\vec{n}_4 = (0, 0, 0, 5, 0, 6)$ on switch matrices $M1$, $M2$, $M3$, and $M4$ of size $w = 6$, respectively. In particular, they are the only configurations for routing $\vec{n}_1, \dots, \vec{n}_4$ on $M1, \dots, M4$. Clearly, for a switch matrix M to be quasi-universal, $\vec{n}_i, 1 \leq i \leq 4$, must be routable on M . This observation motivated our construction for the *diagonal switch matrix* shown in Fig. 6. For the purpose of concise description, we refer to the *subdiagonals* of a switch matrix M as the conceptual slanted lines parallel and adjacent to the two diagonals of M . Therefore, there are four

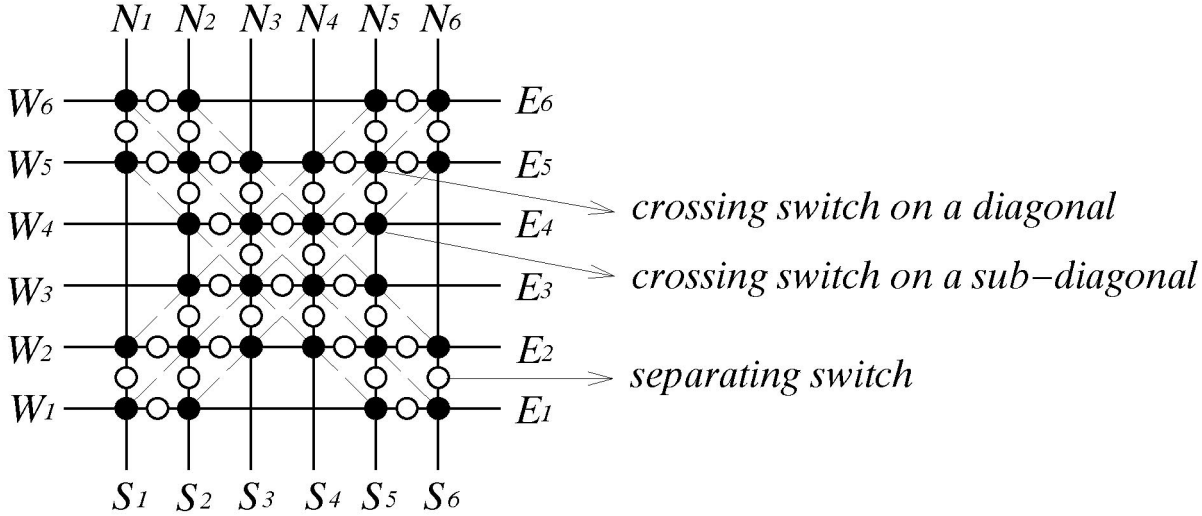

Fig. 6. The diagonal switch matrix of size 6 (D_6).

subdiagonals on each switch matrix (see Fig. 6). A diagonal switch matrix D is constructed based on the following three rules:

- Rule 1: Place crossing switches on the two diagonals of D ;
- Rule 2: Place crossing switches on the four sub-diagonals of D ;
- Rule 3: Place separating switches between the diagonals and subdiagonals of D .

4.2 Proof of the Quasi-Universality

In this section, we show that the diagonal switch matrices constructed by the procedures mentioned earlier are “cheapest” Q-USM. Let

$$\Omega_w = \{(w, w, 0, 0, 0, 0)\} \cup \{(n_1, n_2, n_3, n_4, n_5, n_6) \mid n_1 + n_3 + n_6 \leq w, n_2 + n_3 + n_4 \leq w, n_1 + n_4 + n_5 \leq w, n_2 + n_5 + n_6 \leq w, n_1 + n_2 + \max\{n_3 + n_5, n_4 + n_6\} \leq 2w - 1\}.$$

To prove that a diagonal switch matrix D_w is quasi-universal, we must show that all RRVs in Ω_w are routable on D_w . The proof of the quasi-universality is based on mathematical induction and is informally described as follows: It is trivial to show that D_1 and D_2 are quasi-universal. Assume that all diagonal switch matrices are quasi-universal for $w \leq m$. To prove that the claim holds for the case where $w = m + 2$, we give constructive routings for all maximally routable RRVs in $\Omega_{m+2} - \Omega_m$ on D_{w+2} by applying the routings for the cases where $w \leq m$. Further, we claim that the number of switches used by each of our diagonal switch matrices is, in fact, the minimum requirement for a switch matrix to be quasi-universal.

To establish the proof, we first need some definitions and lemmas. Let $r_{+90}(\vec{n})$ ($r_{-90}(\vec{n})$) denote a 90-degree rotation counterclockwise (clockwise), $r_h(\vec{n})$ ($r_v(\vec{n})$) a reflection along the horizontal (vertical) axis for a routing configuration for \vec{n} . For example, if

$$\begin{aligned} \vec{n} &= (1, 2, 3, 4, 5, 6), \\ r_{+90}(\vec{n}) &= (2, 1, 4, 5, 6, 3), \\ r_{-90}(\vec{n}) &= (2, 1, 6, 3, 4, 5), \\ r_h(\vec{n}) &= (1, 2, 6, 5, 4, 3), \end{aligned}$$

and $r_v(\vec{n}) = (1, 2, 4, 3, 6, 5)$. We have the following definition and lemmas:

Definition 3. Two routing configurations for \vec{n} and \vec{m} are equivalent if \vec{n} (\vec{m}) can be obtained by performing a sequence of r_{+90} , r_{-90} , r_h , and/or r_v operations on \vec{m} (\vec{n}). We say that \vec{n} and \vec{m} are in the same equivalence class and denote \vec{n} and \vec{m} by $\vec{n} \equiv \vec{m}$.

Lemma 2. $\forall \vec{m}, \vec{n}, \vec{m} \equiv \vec{n} \implies (\vec{m} \times D \iff \vec{n} \times D)$.

Proof. Since the diagonal switch matrix D is symmetrical, we can obtain the same diagonal switch matrix by performing the rotation or reflection operations. The claim thus follows. \square

Lemma 3.

$$\begin{aligned} (n_1, n_2, n_3, n_4, n_5, n_6) \times D_w \implies \\ (n_1 + 2, n_2 + 2, n_3, n_4, n_5, n_6) \times D_{w+2}. \end{aligned}$$

Proof. If $\vec{n} = (n_1, n_2, n_3, n_4, n_5, n_6) \times D_w$, \vec{n} must satisfy (5)-(9), according to Lemma 1. When routing $\vec{n}' = (n_1 + 2, n_2 + 2, n_3, n_4, n_5, n_6)$ on D_{w+2} (see Fig. 7), we can use tracks t_1 and t_2 (t_3 and t_4) to preroute two type-1 (type-2) nets. Hence, as illustrated in Fig. 7, the routing on the remaining part of D_{w+2} is identical to routing \vec{n} on D_w . The claim thus follows. \square

Lemma 4.

$$\begin{aligned} (n_1, n_2, n_3, n_4, n_5, n_6) \times D_w \implies \\ (n_1, n_2, n_3 + 1, n_4 + 1, n_5 + 1, n_6 + 1) \times D_{w+2}. \end{aligned}$$

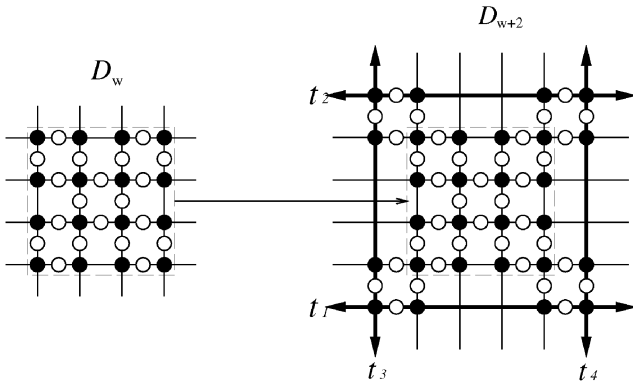

Fig. 7. Prerouting two type-1 nets and two type-2 nets on D_{w+2} .

Proof. If $\vec{n} = (n_1, n_2, n_3, n_4, n_5, n_6) \propto D_w$, \vec{n} must satisfy (5)-(9), according to Lemma 1. When routing $\vec{n}' = (n_1, n_2, n_3 + 1, n_4 + 1, n_5 + 1, n_6 + 1)$ on D_{w+2} (see Fig. 8), we can use the crossing switches on the four corners of D_{w+2} to preroute a type-3, a type-4, a type-5, and a type-6 nets. As illustrated in Fig. 8, the routing on the remaining part of D_{w+2} is identical to routing \vec{n} on D_w . Therefore, $\vec{n}' \propto D_{w+2}$. \square

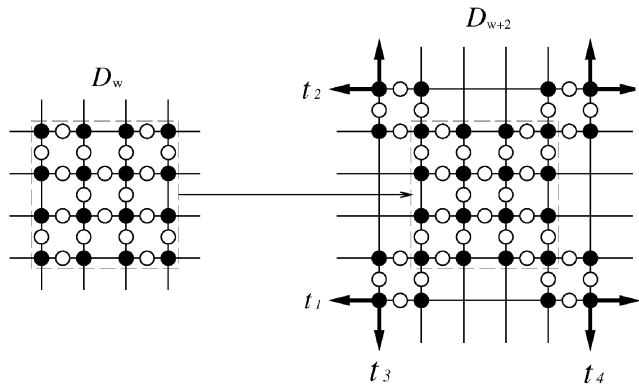

Fig. 8. Prerouting a type-3, a type-4, a type-5, and a type-6 nets on the respective four corners of D_{w+2} .

Lemma 5.

$$(n_1, n_2, n_3, n_4, n_5, n_6) \propto D_w \implies (n_1 + 1, n_2 + 1, n_3 + 1, n_4, n_5, n_6) \propto D_{w+2}$$

(also,

$$(n_1 + 1, n_2 + 1, n_3, n_4 + 1, n_5, n_6), (n_1 + 1, n_2 + 1, n_3, n_4, n_5 + 1, n_6)$$

and $(n_1 + 1, n_2 + 1, n_3, n_4, n_5, n_6 + 1) \propto D_{w+2}$).

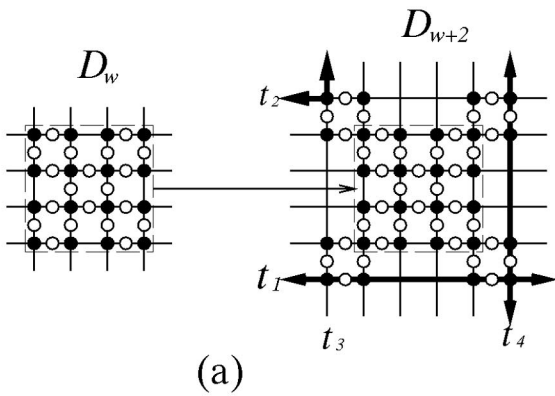

(a)

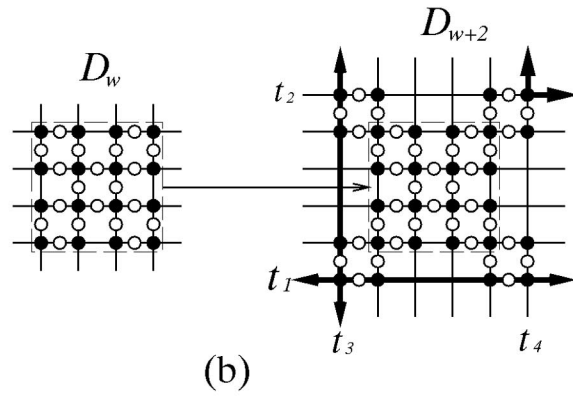

(b)

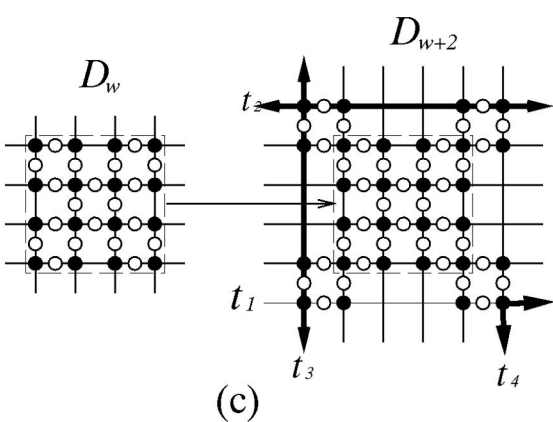

(c)

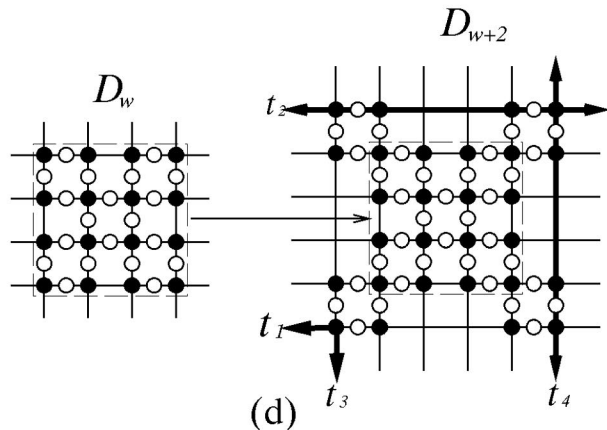

(d)

Fig. 9. Prerouting a type-1, a type-2 nets on two outermost tracks and a corresponding bent net on the unused corner.

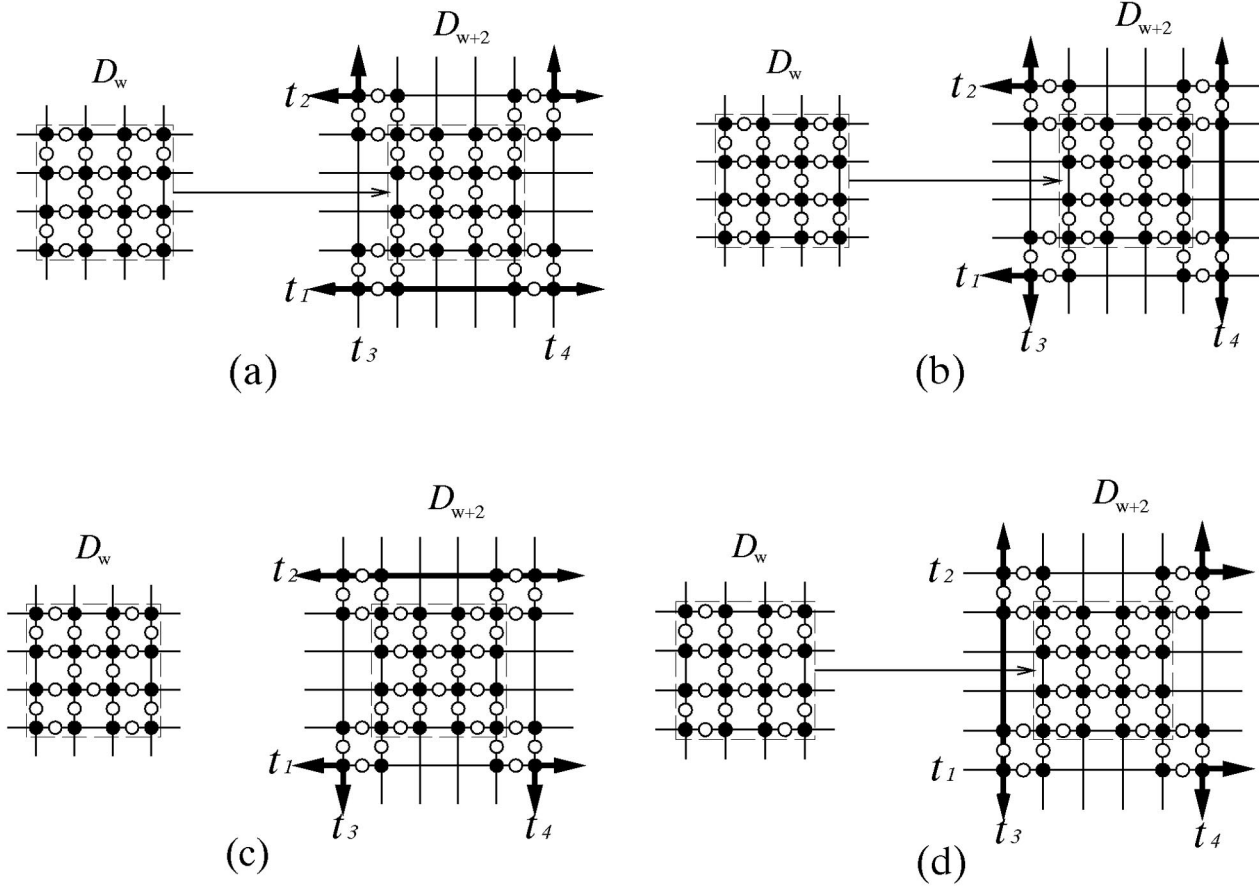

Fig. 10. Prerouting two bent nets on the corresponding corners and a straight net on the unused outermost track.

Proof. If $\vec{n} = (n_1, n_2, n_3, n_4, n_5, n_6) \propto D_w$, \vec{n} must satisfy (5)-(9), according to Lemma 1. When routing $\vec{n}' = (n_1 + 1, n_2 + 1, n_3 + 1, n_4, n_5, n_6)$ on D_{w+2} (see Fig. 9a), we can use the bottom- and right-most tracks of D_{w+2} to preroute a type-1 and a type-2 nets, the crossing switch on the upper-left corner of D_{w+2} to preroute a type-3 net. As illustrated in Fig. 9a, the routing on the remaining part of D_{w+2} is reduced to routing \vec{n} on D_w . Applying similar techniques, the RRV $\vec{n}' = (n_1 + 1, n_2 + 1, n_3, n_4 + 1, n_5, n_6)$, $(n_1 + 1, n_2 + 1, n_3, n_4, n_5 + 1, n_6)$ or $(n_1 + 1, n_2 + 1, n_3, n_4, n_5, n_6 + 1)$ can also be routed on D_{w+2} (see Fig. 9b, Fig. 9c, Fig. 9d). Therefore, $\vec{n}' \propto D_{w+2}$. \square

Lemma 6.

$$(n_1, n_2, n_3, n_4, n_5, n_6) \propto D_w \implies (n_1 + 1, n_2, n_3 + 1, n_4 + 1, n_5, n_6) \propto D_{w+2}$$

(also,

$$(n_1, n_2 + 1, n_3 + 1, n_4, n_5, n_6 + 1), (n_1 + 1, n_2, n_3, n_4, n_5 + 1, n_6 + 1)$$

and $(n_1, n_2 + 1, n_3, n_4 + 1, n_5 + 1, n_6) \propto D_{w+2}$).

Proof. If $\vec{n} = (n_1, n_2, n_3, n_4, n_5, n_6) \propto D_w$, \vec{n} must satisfy (5)-(9), according to Lemma 1. When routing $\vec{n}' = (n_1 + 1, n_2, n_3 + 1, n_4 + 1, n_5, n_6)$ on D_{w+2} (see Fig. 10), we can use the crossing switches on the two upper corners of

D_{w+2} to preroute a type-3 and a type-4 nets, and the bottom-most track to preroute a type-1 net. As illustrated in Fig. 10a, the routing on the remaining part of D_{w+2} is reduced to routing \vec{n} on D_w . Applying similar techniques, the RRV $\vec{n}' = (n_1, n_2 + 1, n_3 + 1, n_4, n_5, n_6 + 1)$, $(n_1 + 1, n_2, n_3, n_4, n_5 + 1, n_6 + 1)$ or $(n_1, n_2 + 1, n_3, n_4 + 1, n_5 + 1, n_6)$ can also be routed on D_{w+2} (see Fig. 10b, Fig. 10c, Fig. 10d). Therefore, $\vec{n}' \propto D_{w+2}$. \square

Lemmas 3-6 give constructive routings for most maximally routable RRVs in $\Omega_{w+2} - \Omega_w$ on D_{w+2} by extending the routings for D_w . However, there exist some RRVs in $\Omega_{w+2} - \Omega_w$ that can not be derived from Lemmas 3-6. We proceed to identify those RRVs in the following discussion. If an RRV $\vec{n} = (n_1, n_2, n_3, n_4, n_5, n_6)$ is nontrivial for D_w , then any of the following RRVs (say \vec{n}')

TABLE 1
The Five Classes of Generic Maximally Routable RRVs on D_{w+2} that Are Underivable from Ω_w

Class	Type of RRVs
Class 1	$[(1, 0, w + 1, 1, w, 0)]$
Class 2	$[(2, 1, w, 1, w - 1, 0)]$
Class 3	$[(a, a, w - a + 2, 0, w - a + 1, 0)]$, where $a = 0 \vee 1$
Class 4	$[(a, a, w - a + 1, 1, w - a + 1, 1)]$, where $a = 0 \vee 1$
Class 5	$[(a, a - 1, w - a + 2, 0, w - a + 2, 0)]$, where $a = 1 \vee 2$

$$(n_1 + 2, n_2 + 2, n_3, n_4, n_5, n_6), \quad n'_1 + n'_3 + n'_6 \leq w + 2, \quad (10)$$

$$(n_1, n_2, n_3 + 1, n_4 + 1, n_5 + 1, n_6 + 1), \quad n'_2 + n'_3 + n'_4 \leq w + 2, \quad (11)$$

$$(n_1 + 1, n_2 + 1, n_3 + 1, n_4, n_5, n_6), \quad n'_1 + n'_4 + n'_5 \leq w + 2, \quad (12)$$

$$(n_1 + 1, n_2 + 1, n_3, n_4 + 1, n_5, n_6), \quad n'_2 + n'_5 + n'_6 \leq w + 2, \quad (13)$$

$$(n_1 + 1, n_2 + 1, n_3, n_4 + 1, n_5, n_6 + 1), \quad n'_1 + n'_2 + \max\{n'_3 + n'_5, n'_4 + n'_6\} \leq 2(w + 2) - 1, \quad (14)$$

$$(n_1 + 1, n_2, n_3 + 1, n_4 + 1, n_5, n_6), \quad n'_1 \geq 2 \wedge n'_2 \geq 2. \quad (15)$$

$$(n_1 + 1, n_2, n_3, n_4, n_5 + 1, n_6 + 1),$$

$$(n_1, n_2 + 1, n_3 + 1, n_4, n_5, n_6 + 1),$$

and

$$(n_1, n_2 + 1, n_3, n_4 + 1, n_5 + 1, n_6)$$

is nontrivial for D_{w+2} . We say an RRV such as \vec{n}' is *derivable* from Ω_w since it is in Ω_{w+2} and can be obtained by performing some operation defined in Lemmas 3-6 on an RRV $\vec{n} \in \Omega_w$; it is *underivable*, otherwise. Based on Lemmas 3-6, we have the fact that $\vec{n} \propto D_w \implies \vec{n}' \propto D_{w+2}$. Do there exist any underivable RRVs? As an example, $(0, 0, w + 1, 1, w + 1, 1) \in \Omega_{w+2}$ is underivable from Ω_w . (At first glance, it seems that the RRV can be obtained by performing the operation defined in Lemma 4 on $(0, 0, w, 0, w, 0)$; unfortunately, $(0, 0, w, 0, w, 0) \notin \Omega_w$.) We have the following lemmas.

Lemma 7. Table 1 lists all maximally underivable RRVs in $\Omega_{w+2} - \Omega_w$.

Proof. We partition all maximal, nontrivial RRVs $\vec{n}' = (n'_1, n'_2, n'_3, n'_4, n'_5, n'_6)$ into five sets A, B, \dots, E as follows:

$$\begin{aligned} A &= \{\vec{n}' | \vec{n}' \in \Omega_{w+2} - \Omega_w, n'_1 \geq 2 \wedge n'_2 \geq 2\} \\ B &= \{\vec{n}' | \vec{n}' \in \Omega_{w+2} - \Omega_w, n'_3 \geq 1 \wedge n'_4 \geq 1 \wedge n'_5 \geq 1 \wedge n'_6 \geq 1\} \\ C &= \{\vec{n}' | \vec{n}' \in \Omega_{w+2} - \Omega_w, n'_1 \geq 1 \wedge n'_2 \geq 1 \wedge n'_3 \geq 1\} \\ &\quad \cup \{\vec{n}' | \vec{n}' \in \Omega_{w+2} - \Omega_w, n'_1 \geq 1 \wedge n'_2 \geq 1 \wedge n'_4 \geq 1\} \\ &\quad \cup \{\vec{n}' | \vec{n}' \in \Omega_{w+2} - \Omega_w, n'_1 \geq 1 \wedge n'_2 \geq 1 \wedge n'_5 \geq 1\} \\ &\quad \cup \{\vec{n}' | \vec{n}' \in \Omega_{w+2} - \Omega_w, n'_1 \geq 1 \wedge n'_2 \geq 1 \wedge n'_6 \geq 1\} \\ D &= \{\vec{n}' | \vec{n}' \in \Omega_{w+2} - \Omega_w, n'_1 \geq 1 \wedge n'_3 \geq 1 \wedge n'_4 \geq 1\} \\ &\quad \cup \{\vec{n}' | \vec{n}' \in \Omega_{w+2} - \Omega_w, n'_1 \geq 1 \wedge n'_5 \geq 1 \wedge n'_6 \geq 1\} \\ &\quad \cup \{\vec{n}' | \vec{n}' \in \Omega_{w+2} - \Omega_w, n'_2 \geq 1 \wedge n'_3 \geq 1 \wedge n'_6 \geq 1\} \\ &\quad \cup \{\vec{n}' | \vec{n}' \in \Omega_{w+2} - \Omega_w, n'_2 \geq 1 \wedge n'_4 \geq 1 \wedge n'_5 \geq 1\} \end{aligned}$$

Set E : The remaining RRVs.

We first prove that all RRVs in A are derivable. For each $\vec{n}' = (n'_1, n'_2, n'_3, n'_4, n'_5, n'_6) \in A$, \vec{n}' satisfies the following set of inequalities (by Lemma 1):

By Lemma 3, \vec{n}' can be derived from from

$$\begin{aligned} \vec{n} &= (n_1, n_2, n_3, n_4, n_5, n_6), \\ n_1 &= n'_1 - 2, \\ n_2 &= n'_2 - 2, \\ n_3 &= n'_3, \\ n_4 &= n'_4, \\ n_5 &= n'_5, \\ n_6 &= n'_6. \end{aligned}$$

Substituting \vec{n} for \vec{n}' in (10), \dots , (24), we have

$$n_1 + n_3 + n_6 \leq w,$$

$$n_2 + n_3 + n_4 \leq w,$$

$$n_1 + n_4 + n_5 \leq w,$$

$$n_2 + n_5 + n_6 \leq w,$$

$$n_1 + n_2 + \max\{n_3 + n_5, n_4 + n_6\} \leq 2w - 1.$$

Therefore, $\vec{n} \in \Omega_w$. The claim that all RRVs in Set A are

derivable holds.

We then identify all underivable RRVs in $B - A$. For each $\vec{n}' = (n'_1, n'_2, n'_3, n'_4, n'_5, n'_6) \in B - A$, \vec{n}' satisfies the following set of inequalities:

$$n'_1 + n'_3 + n'_6 \leq w + 2, \quad (16)$$

$$n'_2 + n'_3 + n'_4 \leq w + 2, \quad (17)$$

$$n'_1 + n'_4 + n'_5 \leq w + 2, \quad (18)$$

TABLE 2
Capacity Comparison of the Universal Switch Modules and the Diagonal Switch Matrices

w	Routing capacity		Capacity ratio $ F_{D_w} / F_{U_w} $
	Universal $ F_{U_w} $	Diagonal (Q-USM) $ F_{D_w} $	
2	56	52	0.929
4	641	633	0.988
6	3,616	3,604	0.997
10	41,336	41,316	≈ 1
15	334,680	334,650	≈ 1
20	1,573,121	1,573,081	≈ 1

$$n'_2 + n'_5 + n'_6 \leq w + 2, \quad (19)$$

$$n'_1 + n'_2 + \max\{n'_3 + n'_5, n'_4 + n'_6\} \leq 2(w + 2) - 1, \quad (20)$$

$$n'_3 \geq 1 \wedge n'_4 \geq 1 \wedge n'_5 \geq 1 \wedge n'_6 \geq 1 \text{ and } \vec{n}' \notin A. \quad (21)$$

By Lemma 4, \vec{n}' can be derived from

$$\begin{aligned} \vec{n}' &= (n_1, n_2, n_3, n_4, n_5, n_6), \\ n_1 &= n'_1, \\ n_2 &= n'_2, \\ n_3 &= n'_3 - 1, \\ n_4 &= n'_4 - 1, \\ n_5 &= n'_5 - 1, \\ n_6 &= n'_6 - 1. \end{aligned}$$

Substituting \vec{n} for \vec{n}' in (16), ..., (20), we have

$$n_1 + n_3 + n_6 \leq w, \quad (22)$$

$$n_2 + n_3 + n_4 \leq w, \quad (23)$$

$$n_1 + n_4 + n_5 \leq w, \quad (24)$$

$$n_2 + n_5 + n_6 \leq w, \quad (25)$$

$$n_1 + n_2 + \max\{n_3 + n_5, n_4 + n_6\} \leq 2w + 1. \quad (26)$$

By (9) in Lemma 1, $\vec{n} \in \Omega_w$ except that

$$n_1 + n_2 + n_3 + n_5 = 2w + 1, \quad (27)$$

$$n_1 + n_2 + n_4 + n_6 = 2w + 1, \quad (28)$$

$$n_1 + n_2 + n_3 + n_5 = 2w, \text{ or} \quad (29)$$

$$n_1 + n_2 + n_4 + n_6 = 2w. \quad (30)$$

We show that (27) and (28) are illogical. Combining (22) and (23), (23) and (24), (22) and (25), and (24) and (25), we have

$$n_1 + n_2 + n_4 + n_6 + 2n_3 \leq 2w, \quad (31)$$

$$n_1 + n_2 + n_3 + n_5 + 2n_4 \leq 2w, \quad (32)$$

$$n_1 + n_2 + n_3 + n_5 + 2n_6 \leq 2w, \quad (33)$$

$$n_1 + n_2 + n_4 + n_6 + 2n_5 \leq 2w. \quad (34)$$

By (28) and (31), we have

$$\begin{aligned} 2w + 1 &= n_1 + n_2 + n_4 + n_6 \\ &\leq n_1 + n_2 + n_4 + n_6 + 2n_3 \\ &\leq 2w, \end{aligned}$$

a contradiction. Similarly, (27) is illogical. Therefore, we need to consider only (29) and (30).

We identify the underivable RRVs induced by (29) and (30) in the following. Subtracting (29) from (32) and (33), we have $n_4 = n_6 = 0$. Substituting zeros for n_4 and n_6 in (22), ..., (25), we have

$$n_1 + n_3 \leq w, \quad (35)$$

$$n_2 + n_3 \leq w, \quad (36)$$

$$n_1 + n_5 \leq w, \quad (37)$$

$$n_2 + n_5 \leq w. \quad (38)$$

By (29), (35), ..., (38), we have

$$n_1 + n_3 = n_2 + n_3 = n_1 + n_5 = n_2 + n_5 = w.$$

Therefore, $n_1 = n_2$ and $n_3 = n_5$. Since $\vec{n}' \notin A$ ($\vec{n}' \notin B - A$)

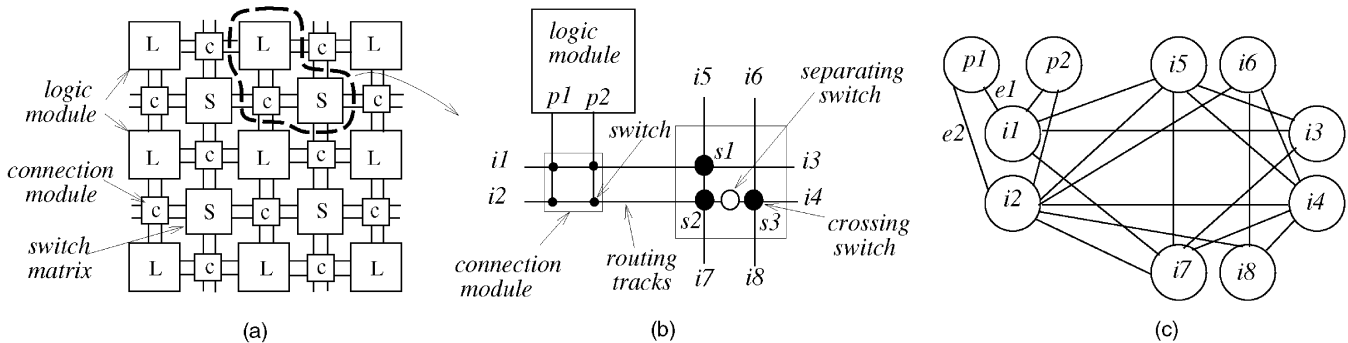

Fig. 11. The graph modeling. (a) A symmetrical-array-based FPGA architecture. (b) Switches in the connection module and the switch matrix. (c) The graph topology.

```

Algorithm: Mutually_Exclusive_Set( $M$ )
Input:  $M$ —A switch-matrix configuration.
Output:  $X$ —Set of mutually exclusive switch pairs in  $M$ .

1   $X \leftarrow \emptyset$ ;
2  for each crossing switch pair  $(s_i, s_j)$  on  $M$ 
3      do if there is no separating switch between  $s_i$  and  $s_j$ 
4          then  $X \leftarrow X \cup \{(s_i, s_j)\}$ ;
5  Output  $X$ .

```

Fig. 12. Algorithm for finding the set of mutually exclusive switch pairs on a switch matrix.

and $n_1 = n'_1$ and $n_2 = n'_2$, $n_1 \leq 1$ and $n_2 \leq 1$. $\vec{n} = (0, 0, w, 0, w, 0)$ or $(1, 1, w-1, 0, w-1, 0)$ satisfies (29). Similarly, we can show that $\vec{n} = (0, 0, 0, w, 0, w)$ or $(1, 1, 0, w-1, 0, w-1)$ are underivable, by (30). Substituting \vec{n}' for \vec{n} , we conclude that

$$\vec{n}' = (0, 0, w+1, 1, w+1, 1), (1, 1, w, 1, w, 1), \\ (0, 0, 1, w+1, 1, w+1),$$

and $(1, 1, 1, w, 1, w)$ are underivable in $B-A$. Let the equivalence class induced by set x be Φ_x . We represent an equivalence class by symbol $[]$. Since $(0, 0, w+1, 1, w+1, 1) \equiv (0, 0, 1, w+1, 1, w+1)$ and

$$(1, 1, w, 1, w, 1) \equiv (1, 1, 1, w, 1, w),$$

we have $\Phi_{A-B} = [(0, 0, w+1, 1, w+1, 1), (1, 1, w, 1, w, 1)]$.

Applying similar techniques, we can obtain all underivable RRVs in $\Omega_{w+2} - \Omega_w$, listed as follows:

$$\Phi_E = [(0, 0, w+2, 0, w+1, 0), (1, 0, w+1, 0, w+1, 0)] \\ /* \text{ in Classes 3 and 5 } */$$

$$\Phi_{B-A} = [(0, 0, w+1, 1, w+1, 1), (1, 1, w, 1, w, 1)] \\ /* \text{ Class 4 } */$$

$$\Phi_{C-(A \cup B)} = [(1, 1, w, 0, w+1, 0), (2, 1, w, 1, w-1, 0), \\ (2, 1, w, 0, w, 0)] \\ /* \text{ in Classes 2, 3, and 5 } */$$

$$\Phi_{D-(A \cup B \cup C)} = [(1, 0, 1, w+1, 0, w)] /* \text{ in Class 1 } */.$$

Table 1 summarizes those underivable RRVs into five equivalence classes. Note that $(1, 0, 1, w+1, 0, w)$ is in Class 1 since it can be obtained by performing the $r_v(\vec{n}')$ operation on $(1, 0, w+1, 1, w, 0)$ (see Section 4.2 for the equivalence operation). (Similarly, $(1, 1, w, 0, w+1, 0)$ belongs to Class 3.) \square

Lemma 8. Algorithms 1-5 (Figs. 14, 15, 16, 17, 18) give respective routing solutions for the five classes of underivable RRVs listed in Table 1.

Based on Lemmas 3-8, we have the following theorem.

Theorem 2. The diagonal switch matrices are quasi-universal.

Proof. By definition, we shall show that all nontrivial RRVs are routable on a diagonal switch matrix D_w . By Lemma 2, we only need to show that there exists one RRV in each maximal, nontrivial equivalence class that is

routable on D_w . We proceed by induction on the size w of a diagonal switch matrix. The claim trivially holds for $w \leq 2$ since it is easy to enumerate all RRVs and check if the RRVs are routable on the corresponding diagonal switch matrices. Assume that all diagonal switch matrices are quasi-universal for $w \leq m$. Consider the case where $w = m+2$. Lemmas 3-6, and Algorithms 155 (Figs. 14, 15, 16, 17, 18) give constructive routings for all maximally routable RRVs in $\Omega_{m+2} - \Omega_m$ by applying the routing for the cases where $w = m$ and $w = m-2$. (See Algorithms 1-5 (Figs. 14, 15, 16, 17, 18) for the routings for RRVs in the five equivalence classes (listed in Table 1) on the diagonal switch matrix.) Hence, by induction, the diagonal switch matrices are quasi-universal. \square

Thus, we have shown that the diagonal switch matrices are quasi-universal and they thus have the maximum routing capacity among all switch matrices of the same size. It is easy to see that each diagonal switch matrix of size w contains $6w-8$ ($6w-9$) crossing switches if w is even (odd), and $8w-12$ separating switches, $w > 1$. In particular, the numbers of switches are also the minimum requirement for a switch matrix to be quasi-universal.

TABLE 3
CGE (Top 5) and SEGA (Bottom 9) Benchmark Circuits

Circuit	#Logic modules	#Nets	#Connections
BUSC	12 × 13	151	392
DMA	16 × 18	213	771
BNRE	21 × 22	352	1257
DFSM	22 × 23	420	1422
Z03	26 × 27	608	2135
9symml	10 × 11	79	259
alu2	13 × 15	153	511
alu4	17 × 19	255	851
apex7	10 × 12	115	300
example2	12 × 14	205	444
k2	20 × 22	404	1256
term1	9 × 10	88	202
too_large	14 × 15	186	519
vda	16 × 17	225	722

TABLE 4
Number of Tracks Needed for Detailed-Routing Completion for the CGE (Top 5) and SEGA (Bottom 9) Benchmark Circuits

Circuit	Number of tracks needed for detailed-routing completion								
	Original order			Non-decreasing length order			Non-increasing length order		
	Q-USM	Random	[19]*	Q-USM	Random	[19]*	Q-USM	Random	[19]*
BUSC	9	9	10	9	9	9	9	9	9
DMA	10	11	10	10	10	10	12	13	12
BNRE	11	12	12	9	9	10	13	14	13
DFSM	11	12	11	10	11	10	12	13	12
Z03	15	15	15	12	13	12	15	16	16
9symml	10	11	10	9	11	10	9	10	10
alu2	11	11	11	9	10	9	11	11	10
alu4	12	13	12	11	12	12	13	13	13
apex7	9	10	10	7	8	8	9	10	10
example2	13	14	14	10	11	10	13	14	13
k2	14	14	14	12	12	12	15	18	14
term1	9	10	9	8	8	8	9	10	9
too_large	11	11	11	10	11	10	11	11	12
vda	13	13	13	11	12	10	14	14	13
Total	158	166	162	137	147	140	165	176	166

The three schemes for net order are 1) original net order as given in the benchmark circuits, 2) shortest net first (nondecreasing order of net lengths), and 3) longest net first (nonincreasing order of net lengths).

Theorem 3. No switch matrix with less than $6w - 8$ ($6w - 9$ if w is odd) crossing switches and $8w - 12$ separating switches can be quasi-universal, $w > 1$.

Proof. Consider the four RRVs

$$(0, 0, w, 0, w - 1, 0), (0, 0, w - 1, 0, w, 0), (0, 0, 0, w, 0, w - 1),$$

and $(0, 0, 0, w - 1, 0, w)$. Since they all satisfy (5)-(9), they must be routable on a quasi-universal switch matrix. The set of switches needed to route the the four RRVs is equivalent to the “union” of the switches in the four corresponding routing topologies shown in Fig. 5 (Fig. 5 shows an example for the case where $w = 6$). It is thus easy to see that $6w - 8$ ($6w - 9$ if w is odd) crossing switches and $8w - 12$ separating switches, $w > 1$, are the minimum requirement for a switch matrix to be quasi-universal by counting the number of switches in the “union” set. \square

TABLE 5
Comparison of the Area Performance by Using the Diagonal Switch Matrices and Randomly Generated Switch Matrices for Various Connection Densities, Based on 15×15 FPGA

Number of connections	#Tracks needed for detailed routing	
	Diagonal	Random
200	12	12
400	16	17
600	22	24
800	31	35
1000	34	38
1200	38	43
1400	40	45

Hence, the diagonal switch matrices are the “cheapest” quasi-universal switch matrices. Note that the number of switches required for a diagonal switch matrix is very small compared to a fully populated switch matrix which has w^2 crossing switches and $2w^2 - 2w$ separating switches.

4.3 Routing-Capacity Analysis

Let D_w and U_w be a diagonal switch matrix and a universal switch module of size w , respectively. Let F_{D_w} be the feasible set for D_w ; that is, $F_{D_w} = \{\vec{n} | \vec{n} \propto D_w\}$. F_{U_w} is similarly defined. We have the following theorem.

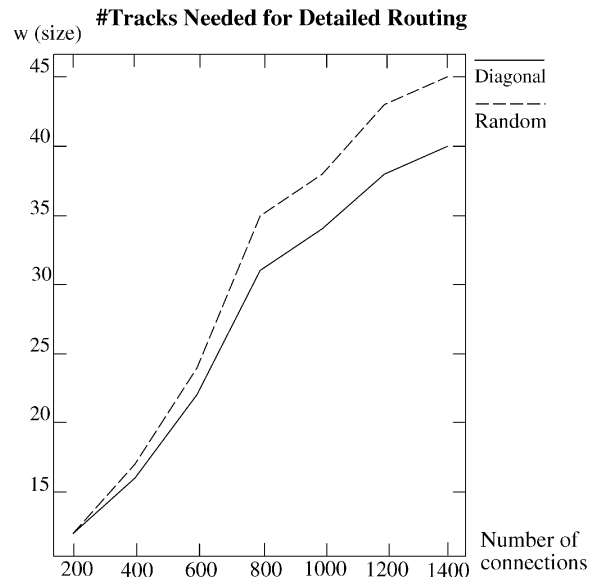

Fig. 13. Comparison of the area performance by using the diagonal switch matrices and randomly generated switch matrices for different numbers of connections on a 15×15 FPGA.

```

Algorithm 1: Diagonal_Switch_Matrix_Class1( $w$ )
Input:  $w + 2$ —Size of the diagonal switch matrix;
Output:  $D(\text{nets})$ —Routings on the diagonal switch matrix;
            $\text{nets}$ —Set of nets.
/* See Figure 6 for the terminal labeling. */
/*  $(W_i, E_i)$ : a net routed between terminals  $W_i$  and  $E_i$  */

1   $\text{nets} \leftarrow \emptyset$ ;
2   $\text{nets} \leftarrow \text{nets} \cup \{(W_1, E_1)\}$ ; /* Type-1 nets */
3   $\text{nets} \leftarrow \text{nets} \cup \{(N_w, E_w)\}$ ; /* Type-4 nets */
4   $\text{nets} \leftarrow \text{nets} \cup \{(W_{w+2}, N_1)\}$ ; /* Type-3 nets */
5  for  $i = 1$  to  $w$  do {
6      $\text{nets} \leftarrow \text{nets} \cup \{(E_{w-i+2}, S_{w-i+3})\}$ ; /* Type-5 nets */
7      $\text{nets} \leftarrow \text{nets} \cup \{(W_{w-i+2}, N_{w-i+2})\}$ ; /* Type-3 nets */
8     } /* for */
9  Output  $D(\text{nets})$ .

```

Fig. 14. Algorithm for routing the maximal underivable Equivalence Class 1 on the diagonal switch matrix D_{w+2} .

Theorem 4.

$$|F_{D_w}| = |F_{U_w}| - 2w$$

$$= \left\lfloor \frac{5}{6!} (2w^6 + 24w^5 + 119w^4 + 312w^3 + 464w^2 + 96w + 144) \right\rfloor.$$

Proof.

$$F_{D_w} = \{ \vec{n} | n_1 + n_3 + n_6 \leq w, \\ n_2 + n_3 + n_4 \leq w, n_1 + n_4 + n_5 \leq w, \\ n_2 + n_5 + n_6 \leq w, \\ n_1 + n_2 + \max\{n_3 + n_5, n_4 + n_6\} \leq (2w - 1) \} \\ \cup \{(w, w, 0, 0, 0, 0)\}.$$

The closed form for the cardinality of F_{D_w} , $w > 0$, can be

obtained as follows:

$$|F_{D_w}| = \left| \{ \vec{n} | n_1 + n_3 + n_6 \leq w, \\ n_2 + n_3 + n_4 \leq w, \\ n_1 + n_4 + n_5 \leq w, \\ n_2 + n_5 + n_6 \leq w \} \right| \\ - \left| \bigcup_{i=0}^{w-1} \{(i, i, 0, w-i, 0, w-i)\} \right| \\ - \left| \bigcup_{i=0}^{w-1} \{(i, i, w-i, 0, w-i, 0)\} \right| \\ = \left\lfloor \frac{5}{6!} (2w^6 + 24w^5 + 119w^4 + 312w^3 + 464w^2 + 384w + 144) \right\rfloor - 2w \\ = \left\lfloor \frac{5}{6!} (2w^6 + 24w^5 + 119w^4 + 312w^3 + 464w^2 + 96w + 144) \right\rfloor.$$

Note that the identity

$$|F_{D_w}| = \left| \{ \vec{n} | n_1 + n_3 + n_6 \leq w, \\ n_2 + n_3 + n_4 \leq w, \\ n_1 + n_4 + n_5 \leq w, \\ n_2 + n_5 + n_6 \leq w \} \right| \\ = \left\lfloor \frac{5}{6!} (2w^6 + 24w^5 + 119w^4 + 312w^3 + 464w^2 + 384w + 144) \right\rfloor$$

is given by [8]. \square

Based on the above lemma, it is simple to verify the

following theorem.

Theorem 5. (Capacity ratio)

1. $|F_{D_w}|/|F_{U_w}|$ is a strictly increasing function of w , $w > 0$;
2. $\lim_{w \rightarrow \infty} |F_{D_w}|/|F_{U_w}| = 1$.

Proof.

1. For $w > 0$,

$$\frac{|F_{D_{w+1}}|}{|F_{U_{w+1}}|} - \frac{|F_{D_w}|}{|F_{U_w}|} = \frac{|F_{U_w}| |F_{D_{w+1}}| - |F_{D_w}| |F_{U_{w+1}}|}{|F_{U_{w+1}}| |F_{U_w}|} \\ = \frac{|F_{D_{w+1}}| (|F_{D_w}| + 2w) - |F_{D_w}| (|F_{D_{w+1}}| + 2w + 2)}{|F_{U_{w+1}}| |F_{U_w}|} \\ = \frac{|F_{D_{w+1}}|^{+2w} |F_{D_{w+1}}|^{-1} |F_{D_{w+1}}|^{-2w} |F_{D_w}|^{-2} |F_{D_w}|}{|F_{U_{w+1}}| |F_{U_w}|} \\ = \frac{2w |F_{D_{w+1}}| - 2w |F_{D_w}| - 2 |F_{D_w}|}{|F_{U_{w+1}}| |F_{U_w}|} \\ = \frac{\vec{A} \vec{w}}{72 |F_{U_{w+1}}| |F_{U_w}|} > 0,$$

where

Algorithm 2: Diagonal_Switch_Matrix_Class2(w, a)
Input: $w + 2$ —Size of the diagonal switch matrix;
 a —Number of type-1 nets.
Output: $D(nets)$ —Routings on the diagonal switch matrix;
 $nets$ —Set of nets.
/* See Figure 6 for the terminal labeling. */
/* (W_i, E_i) : a net routed between terminals W_i and E_i */

```

1  nets ← ∅;
2  nets ← nets ∪ {(Nw+2, Sw+2)}; /* Type-2 nets */
3  for i = 1 to a do {
4    nets ← nets ∪ {(Wi, Ei)}; /* Type-1 nets */
5  } /* for */
6  for i = 1 to a - 1 do {
7    nets ← nets ∪ (Nw-i+2, Ew-i+3); /* Type-4 nets */
8    nets ← nets ∪ (Ww-i+3, Ni); /* Type-3 nets */
9  } /* for */
10 for i = 1 to w - 2a + 3 do {
11  nets ← nets ∪ (Ew-a-i+4, Sw-a-i+4); /* Type-5 nets */
12  nets ← nets ∪ (Ww-a-i+4, Nw-a-i+3); /* Type-3 nets */
13 } /* for */
14 Output  $D(nets)$ .
```

Fig. 15. Algorithm for routing the maximal underivable Equivalence Class 2 on the diagonal switch matrix D_{w+2} .

Algorithm 3: Diagonal_Switch_Matrix_Class3(w, a)
Input: $w + 2$ —Size of the diagonal switch matrix;
 a —Number of type-1 nets.
Output: $D(nets)$ —Routings on the diagonal switch matrix;
 $nets$ —Set of nets.
/* See Figure 6 for the terminal labeling. */
/* (W_i, E_i) : a net routed between terminals W_i and E_i */

```

1  nets ← ∅;
2  for i = 1 to a do {
3    nets ← nets ∪ {(Wi, Ei)}; /* Type-1 nets */
4    nets ← nets ∪ {(Ni, Si)}; /* Type-2 nets */
5  } /* for */
6  for i = 1 to w - a + 1 do {
7    nets ← nets ∪ {(Wa+i, Na+i)}; /* Type-3 nets */
8    nets ← nets ∪ {(Ea+i, Sa+i+1)}; /* Type-5 nets */
9  } /* for */
10 nets ← nets ∪ {(Ww+2, Nw+2)}; /* Type-3 nets */
11 Output  $D(nets)$ .
```

Fig. 16. Algorithm for routing the maximal underivable Equivalence Class 3 on the diagonal switch matrix D_{w+2} .

$$\vec{A} = (10, 126, 637, 1608, 2008, 777, -144),$$

$$\vec{w} = (w^6, w^5, w^4, w^3, w^2, w, 1).$$

Because $\frac{|F_{D_w}|}{|F_{U_w}|} < \frac{|F_{D_{w+1}}|}{|F_{U_{w+1}}|}$, $|F_{D_w}|/|F_{U_w}|$ is a strictly increasing function of w , $w > 0$.

$$2. \lim_{w \rightarrow \infty} \frac{|F_{D_w}|}{|F_{U_w}|} = \lim_{w \rightarrow \infty} \frac{|F_{D_w}|}{|F_{D_w}| + 2w} = 1. \quad \square$$

Therefore, the routing capacity of a diagonal switch matrix converges to that of a universal switch module of the same size. Table 2 summarizes the routing capacities for the

```

Algorithm 4: Diagonal_Switch_Matrix_Class4( $w, a$ )
Input:  $w + 2$ —Size of the diagonal switch matrix;
          $a$ —Number of type-1 nets.
Output:  $D(nets)$ —Routings on the diagonal switch matrix;
          $nets$ —Set of nets.
/* See Figure 6 for the terminal labeling. */
/* ( $W_i, E_i$ ): a net routed between terminals  $W_i$  and  $E_i$  */

1   $nets \leftarrow \emptyset$ ;
2   $nets \leftarrow nets \cup \{(W_1, S_1)\}$ ; /* Type-6 nets */
3  if  $a = 1$  then {
4       $nets \leftarrow nets \cup \{(W_{w+2}, E_{w+2})\}$ ; /* Type-1 nets */
5       $nets \leftarrow nets \cup \{(N_{w+2}, S_{w+2})\}$ ; /* Type-2 nets */
6       $nets \leftarrow nets \cup \{(N_{w+1}, E_{w+1})\}$ ; /* Type-4 nets */
7  } /* if */
8  for  $i = 1$  to  $w - a + 1$  do {
9       $nets \leftarrow nets \cup \{(W_{i+1}, N_i)\}$ ; /* Type-3 nets */
10      $nets \leftarrow nets \cup \{(E_i, S_{i+1})\}$ ; /* Type-5 nets */
11 } /* for */
12 Output  $D(nets)$ .

```

Fig. 17. Algorithm for routing the maximal underivable Equivalence Class 4 on the diagonal switch matrix D_{w+2} .

universal switch module and the diagonal switch matrices and their capacity ratios.

5 GRAPH MODELING FOR DETAILED ROUTING

In the previous section, we showed theoretically that the diagonal switch matrices have high routing capacities. To explore the effects of switch-matrix architectures on chip-level routing, we shall test the area performance of a router on an FPD chip using benchmark circuits. To develop a router for experimentation, we may model an FPD as a graph and apply the graph-search technique to FPD routing. In this section, we use a symmetrical-array-based FPGA as an example to demonstrate the graph modeling.

Given an FPGA architecture, we use a vertex to represent a wire segment or a logic-module pin and an edge to represent a connection that can be established by programming a switch or by using a track in the switch matrix. See Fig. 11 for an illustration. Fig. 11b shows a logic module with two pins on one side. We introduce two vertices p_1 and p_2 for the two pins shown in the figure. There are two horizontal (vertical) routing tracks partitioned into four wire segments (for the portion considered here), two on each of the left and right (the top and bottom) sides of the switch matrix. We introduce a vertex for each wire segment (i_1, i_2, \dots, i_8 in Fig. 11c) and an edge between the two vertices associated with each pair of wire segments abutted on the switch matrix (edges $(i_1, i_3), (i_6, i_8)$, etc.). If there is a crossing switch connected to any pin or wire segment, then introduce an edge between the two corresponding vertices. (Note that the switches in the connection module can be viewed as crossing switches. A connection module is, in fact, a switch module with no separating switches.) For

instance, since pin p_1 can connect to wire segment i_1 (i_2), an edge e_1 (e_2) between vertices p_1 and i_1 (i_2) is created. For each crossing switch, we create an additional four edges for its incident wire segments (thus, a clique for the four vertices associated with those segments is formed). The graph modeling is thus done. In addition to the graph modeling, however, we need to use two data structures to cope with the problems of connection conflicts. The conflicts arise in two forms:

- *Mutually exclusive crossing switches:* Two crossing switches with no separating switch between them are mutually exclusive. For example, in Fig. 11, crossing switches s_1 and s_2 cannot be used for different connections at the same time since there is no separating switch between them. In this case, we say that s_1 and s_2 are in the same *exclusion set*. The algorithm in Fig. 12 provides a method to find the exclusion sets for a switch matrix.
- *Mutually exclusive connections:* Two connections are mutually exclusive if they do not belong to the same net and are incident on the same crossing switch. For example, in Fig. 11, edges (i_1, i_5) and (i_3, i_7) cannot be used for different connections at the same time since the connections are mutually exclusive. It is easy to derive an algorithm similar to The algorithm in Fig. 12 to identify all mutually inclusive connections.

With the data structures, we can incorporate the detection for illegal connections and exclusion sets into a router.

Based on the graph modeling, we may formulate the routing problem as finding a set of disjoint trees (a forest), one tree for a net and each tree connecting all terminals of a

```

Algorithm 5: Diagonal_Switch_Matrix_Class5( $w, a$ )
Input:  $w + 2$ —Size of the diagonal switch matrix;
          $a$ —Number of type-1 nets.
Output:  $D(nets)$ —Routings on the diagonal switch matrix;
          $nets$ —Set of nets.
/* See Figure 6 for the terminal labeling. */
/* ( $W_i, E_i$ ): a net routed between terminals  $W_i$  and  $E_i$  */

1   $nets \leftarrow \emptyset$ ;
2   $nets \leftarrow nets \cup \{(W_{w+2}, E_{w+2})\}$ ; /* Type-1 nets */
3  if  $a = 2$  then {
4       $nets \leftarrow nets \cup \{(W_{w+1}, E_{w+1})\}$ ; /* Type-1 nets */
5       $nets \leftarrow nets \cup \{(N_{w+2}, S_{w+2})\}$ ; /* Type-2 nets */
6  } /* if */
7  for  $i = 1$  to  $w - a + 2$  do {
8       $nets \leftarrow nets \cup \{(W_i, N_i)\}$ ; /* Type-3 nets */
9       $nets \leftarrow nets \cup \{(E_i, S_{i+1})\}$ ; /* Type-5 nets */
10 } /* for */
11 Output  $D(nets)$ .

```

Fig. 18. Algorithm for routing the maximal undervivable Equivalence Class 5 on the diagonal switch matrix D_{w+2} .

net. Any graph search-based algorithm such as maze router can be used for detailed routing.

6 EXPERIMENTAL RESULTS

To explore the effects of switch-matrix architectures on routing, we implemented a maze router based on the graph modeling mentioned in the preceding section in the C language and ran on a Sun Ultra workstation. We tested the area performance of the router based on the CGE [15] and SEGA [14] benchmark circuits. Table 3 gives the names of the circuits, the numbers of logic modules in the FPGAs, and the numbers of nets and connections in the circuits. A logic-module pin was connected to any of the w tracks in the adjacent routing channel. The switch-matrix architectures used were the diagonal switch matrices, randomly generated switch matrices with the same numbers of switches as those in the diagonal switch matrices, and the switch matrices designed by [19].

The quality of a switch matrix was evaluated by the area performance of the detailed router. Table 4 shows the results. For the results listed in this table, we determined the minimum number of tracks w required for 100 percent routing completion for each circuit, using the three kinds of switch matrices. Because net ordering often affects the performance of a maze router, we routed the benchmark circuits by using the following three net-ordering schemes to avoid possible biases: 1) net order as given in the original benchmark circuits, 2) shortest net first (nondecreasing order of net lengths), and 3) longest net first (nonincreasing order of net lengths). Also, since our main goal is to make fair comparisons for various switch-matrix architectures, no rip-and-reroute phase was incorporated in the maze router (optimization might bias the comparison). The running

times ranged from 3 sec for the smallest circuit (9symm1) to 160 sec for the largest one (Z03). Our results show that, among the three kinds of switch matrices, the diagonal switch matrices usually needed the minimum ws for 100 percent routing completion, no matter what order was used. The results show that our diagonal switch matrices can improve the routability at the chip level.

It should be noted that the design in [19] is based on a different switch-matrix routing model from ours—in [19], only one crossing or separating switch can be used for routing a connection on a switch matrix, and at most $2w$ separating switches can be placed on a switch matrix, whereas ours allows multiswitch routing and does not have the upper-bound constraint, $2w$; therefore, it is impossible to make a completely fair comparison with [19]. (This is why we also compared our designs with those randomly generated switch matrices.)

We also performed experiments to explore the effects of net density on the area performance of switch matrices. We randomly generated connections on a 15×15 (number of logic modules) FPGA. For this purpose, we assume that the number of pins on each logic module is unlimited (so that we could test denser circuits). As shown in Table 5 and Fig. 13, the denser the circuit, the better the diagonal switch matrices than the randomly generated switch matrices. This phenomenon reveals the facts that the routability of a single switch matrix plays a more important role when 1) the connection density on a chip gets denser and 2) the switch matrices become larger. Notice that denser applications and larger chips are trends of the commercial applications and products. Therefore, we expect that the switch-matrix architectures will have even greater impact on FPD chip routability than they do now.

7 CONCLUDING REMARKS

We have presented a class of quasi-universal switch matrices and shown theoretically and experimentally that they result in better area performance in routing. Our research also confirms the findings by [6], [8], [15] that switch modules with larger routing capacities often result in better routing solutions. Also, our study has shown that the routability of a single switch matrix plays a more important role when 1) the net density on a chip gets denser, and 2) the switch matrices become larger. Since denser applications and larger chips are trends of the commercial applications and products, the switch-matrix architectures would have even greater impact on FPD chip-level routability than they do now.

To explore the effects of FPD switch-matrix architectures on routing, we adopted the bottom-up approach by optimizing a single switch matrix first (and future work shall extend to the cases for multiple switch matrices in series). The methodology is mainly motivated by the golden rule "optimize the common cases" [10], which is the key to contemporary computer designs. For *real* applications, most connections are short (*the common cases*); for example, about 60 percent (90 percent) of connections in the CGE [15] and SEGA [14] benchmark circuits are routed through no more than two (five) switch modules, independent of the sizes of FPGAs. Therefore, the architecture of a single switch module is of particular importance. In contrast, though theoretically sound and interesting, the worst-case scenario—emphasizing the worst-case routing instance—for exploring the architectural effects is often pathologically pessimistic and rarely corresponds to practical applications. (See [12], the Turing Award lecture by R. M. Karp.) We believe that the average/common-case scenario shall be a superior alternative to architectural design.

ACKNOWLEDGMENTS

This work was partially supported by the National Science Council of Taiwan under Grant No. NSC-87-2215-E-009-041.

REFERENCES

- [1] Actel Corp., *FPGA Data Book and Design Guide*, 1996.
- [2] Altera Corp., *FLEX 10K Handbook*, 1996.
- [3] Aptix Inc., *FPIC AX1024D*, Preliminary Data Sheet, Aug. 1992.
- [4] AT&T Microelectronics, *AT&T Field-Programmable Gate Arrays Data Book*, Apr. 1995.
- [5] N. Bhat and D. Hill, "Routable Technology Mapping for LUT FPGAs," *Proc. IEEE Int'l Conf. Computer Design*, pp. 95-98, 1992.
- [6] S.D. Brown, J. Rose, and Z.G. Vranesic, "A Stochastic Model to Predict the Routability of Field-Programmable Gate Arrays," *IEEE Trans. Computer-Aided Design*, vol. 12, no. 12, pp. 1,827-1,838, Dec. 1993.
- [7] Y.-W. Chang, D.F. Wong, and C.K. Wong, "Design and Analysis of FPGA/FPIC Switch Modules," *Proc. IEEE Int'l Conf. Computer Design*, pp. 394-401, Austin, Tex., Oct. 1995.
- [8] Y.-W. Chang, D.F. Wong, and C.K. Wong, "Universal Switch Modules for FPGA Design," *ACM Trans. Design Automation of Electronic Systems*, vol. 1, no. 1, pp. 80-101, Jan. 1996.
- [9] A. El Gamal et al., "An Architecture for Electrically Configurable Gate Arrays," *IEEE J. Solid-State Circuits*, vol. 24, no. 2, pp. 394-398, Apr. 1989.
- [10] J.L. Hennessy and D.A. Patterson, *Computer Architecture: A Quantitative Approach*, second ed. Morgan Kaufmann, 1996.

- [11] H.C. Hsieh et al., "Third-Generation Architecture Boosts Speed and Density of Field-Programmable Gate Arrays," *Proc. IEEE Custom Integrated Circuits Conf.*, pp. 31.2.1-31.2.7, May 1990.
- [12] R.M. Karp, "Combinatorics, Complexity, and Randomness," *Comm. ACM*, vol. 29, no. 2, pp. 98-109, 1986.
- [13] C.Y. Lee, "An Algorithm for Path Connections and Its Applications," *IRE Trans. Electronic Computers*, vol. 10, pp. 346-365, Sept. 1961.
- [14] G.G. Lemieux and S.D. Brown, "A Detailed Routing Algorithm for Allocating Wire Segments in Field-Programmable Gate Arrays," *Proc. ACM/SIGDA Physical Design Workshop*, pp. 215-216, Lake Arrowhead, Calif., 1993.
- [15] J. Rose and S. Brown, "Flexibility of Interconnection Structures for Field-Programmable Gate Arrays," *IEEE J. Solid State Circuits*, vol. 26, no. 3, pp. 277-282, Mar. 1991.
- [16] Y. Sun, T.-C. Wang, C.K. Wong, and C.L. Liu, "Routing for Symmetric FPGAs and FPICs," *Proc. IEEE/ACM Int'l Conf. Computer-Aided Design*, pp. 486-490, Santa Clara, Calif., Nov. 1993.
- [17] S. Trimberger and M. Chene, "Placement-Based Partitioning for Lookup-Table-Based FPGA," *Proc. IEEE Int'l Conf. Computer Design*, pp. 91-94, 1992.
- [18] Xilinx Inc., *The Programmable Logic Data Book*, 1996.
- [19] K. Zhu, D.F. Wong, and Y.-W. Chang, "Switch Module Design with Application to Two-Dimensional Segmentation Design," *Proc. IEEE/ACM Int'l Conf. Computer-Aided Design*, pp. 481-486, Santa Clara, Calif., Nov. 1993.



Guang-Ming Wu received the BS degree in information and computer engineering from Chung Yuan Christian University, Chun-Li, Taiwan, Republic of China, in 1990, and the MS degree in computer science from Chao Tung University, Hsinchu, Taiwan, Republic of China, in 1994. He is currently working toward the PhD degree in computer science from Chao Tung University. His research interests include design automation and optimization in VLSI design.



Yao-Wen Chang (S'94-M'96) received the BS degree in computer science and information engineering from National Taiwan University in 1988, and the MS and the PhD degrees in computer science from the University of Texas at Austin in 1993 and 1996, respectively.

He was with the IBM T.J. Watson Research Center, Yorktown Heights, New York, in the VLSI group during the summer of 1994. Since 1996, he has been an associate professor in the Department of Computer and Information Science at National Chiao Tung University, Hsinchu, Taiwan. His current research interests lie in design automation, architectures, and systems for VLSI and combinatorial optimization.

Dr. Chang received the Best Paper Award at the 1995 IEEE International Conference on Computer Design (ICCD-95) for his work on FPGA routing and the MS Thesis Supervision Award from the Institute of Electrical Engineering, Taiwan, in 1998. He is a member of the IEEE, the IEEE Circuits and Systems Society, the ACM, and ACM/SIGDA.