

Wavelength-selectable single-longitudinal-mode Fabry–Perot laser source using inter-injection mode-locked technique

Chien-Hung Yeh^{a,*}, Chi-Wai Chow^b

^a Information and Communications Research Laboratories, Industrial Technology Research Institute (ITRI), Chutung, Hsinchu 31040, Taiwan

^b Department of Photonics and Institute of Electro-Optical Engineering, National Chiao Tung University, Hsinchu 30010, Taiwan

ARTICLE INFO

Article history:

Received 15 March 2010

Revised 5 May 2010

Available online 26 June 2010

Keywords:

Wavelength-tuning

Fabry–Perot

Inter-injection

ABSTRACT

In this paper, a simple fiber coupled laser configuration to generate stable and tunable single-longitudinal-mode (SLM) optical output based on a pair of Fabry–Perot laser diode (FP-LD) using inter-injection operation is proposed and experimentally demonstrated. By adjusting the tunable filter inside the laser cavity to align the corresponding mode of the FP-LDs, the lasing wavelength can be tuned in the wavelength range of 1528.6–1562.2 nm with 1.4 nm tuning step. In addition, the output performance of the proposed fiber coupled laser has also been discussed.

© 2010 Elsevier Inc. All rights reserved.

1. Introduction

Stable and wavelength-tunable fiber lasers are necessary and important for the optical fiber communications and optical switching systems. Recently, several wavelength-tunable fiber lasers have been reported and demonstrated, such as the rear-sampled grating reflector (GCSR) laser with a grating-assisted codirectional coupler, sample grating or super structure grating (SSG) distributed Bragg reflector (DBR) lasers, and high-speed electroabsorption SSG-DBR lasers etc. [1–4]. However, these lasers were quite costly for wavelength division multiplexed (WDM) applications. In order to reduce the laser cost, several optical injection techniques based on FP-LD have been studied [5–8]. Particularly, low-cost optical transmitter in optical line terminal (OLT) and optical network units (ONUs) are required for next generation fiber to the home (FTTH) applications. Hence, the cost-effective injection-locked FP-LD is considered as an attractive option for the time division multiplexed (TDM) or WDM passive optical network (PON) communications nowadays [5–8].

In this paper, we propose and experimentally demonstrate a widely wavelength-tunable fiber coupled laser in SLM operation based on a pair of FP-LDs using inter-injection technique. In addition, the output performances of the proposed fiber coupled laser are also investigated and discussed. The proposed fiber coupled laser could be a low-cost optical transmitter for WDM applications.

2. Experiments and discussion

Fig. 1 shows the experimental setup of the proposed tunable fiber coupled laser. The proposed laser is consisted of FP-LD₁ and FP-LD₂, a polarization controller (PC), a 1 × 2 and 50:50 optical coupler (CP) and a tunable bandpass filter (TBF). The FP-LD₁ and FP-LD₂ in the proposed laser scheme uses the inter-injection for SLM lasing. Both FP-LD₁ and FP-LD₂ have similar optical output characteristics. The mode-spacing ($\Delta\lambda$) and threshold current (I_{thres}) of the two FP-LDs are 1.4 nm and 9.5 mA, respectively. In the experiment, the mode-spacing could be matched to each other by adjusting bias current and temperature on the two FP-LDs. The PC inside the gain cavity is used to maintain the polarization state of the inter-injected light and keep the maximum output power. The 3-dB bandwidth and insertion loss of TBF are 0.4 nm and 4.5 dB, respectively. To achieve the SLM output tuning, the filtering mode of TBF is adjusted to align the corresponding longitudinal modes of the FP-LDs. A tuning step of 1.4 nm is achieved and it is determined by the mode-spacing of the FP-LDs. To measure the output power and lasing wavelength, a power meter (PM) and an optical spectrum analyzer (OSA) with a 0.05 nm resolution are used for the measurement.

Fig. 2a and b shows the free-run spectra of the FP-LD₁ and FP-LD₂ without inter-injection. The mode-spacing of FP-LD₁ can match with FP-LD₂ by proper tuning the bias current and temperature. The bias current and temperature of FP-LD₁ and FP-LD₂ are 21 mA and 18 °C; and 22 mA and 25 °C, respectively. When the inter-injection is performed, the lasing wavelength of the proposed FP-LD-based laser can be locked and tuned in the wavelength range of 1528.6–1562.6 nm, as shown in Fig. 3. Fig. 4 shows the output power (measured by using a PM) and the side-mode

* Corresponding author.

E-mail address: depew@itri.org.tw (C.-H. Yeh).

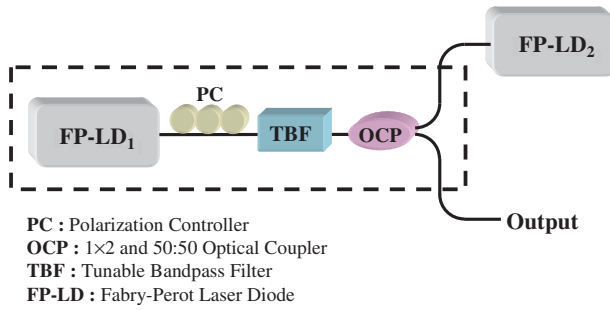

Fig. 1. Experimental setup of the proposed wavelength-tuning fiber coupled laser with inter-injection method.

suppress ratio (SMSR) (measured by an OSA) versus the different lasing wavelengths with 1.4 nm tuning step in the wavelengths of 1528.6–1562.6 nm. The maximum and minimum output power are -13.4 and -5.3 dBm ($\Delta P_{\max} = 8.1$ dB) at 1528.6 and 1544.7 nm, respectively. The maximum SMSR is 50.84 dB at 1547.44 nm with -6.25 dBm output power. And the minimum SMSR of 36.5 dB is observed at 1528.6 nm. The output power and SMSR can be larger than -8.2 dBm and 42 dB in the wavelengths of 1535.3–1558.5 nm. Due to the smaller output powers of two FP-LDs in two sides (as shown in Fig. 2), the observed output power and SMSR of the proposed laser would drop gradually in both long and short wavelength sides, as also shown in Fig. 4.

To analyze the output efficiency of the proposed laser, the temperature of the FP-LD is adjusted. Initially, the lasing wavelength of the laser is 1544.7 nm with -5.3 dBm output power, and the FP-LD₁ operates on 21 mA at 18 °C and the FP-LD₂ operates on 22 mA at 25 °C. In this measurement, the temperature of the FP-LD₁ is changed from 14 to 22 °C and FP-LD₂ is kept constant. Fig. 5 shows the (a) output power variations, (b) central wavelength difference, and (c) SMSR of the proposed laser under different temperature of the FP-LD₁ from 14 to 22 °C. When the temperature is varied in the operation range, the maximum variations of output power and central wavelength are 14.2 dB and 0.16 nm, respectively, as shown in Fig. 5a and b. Besides, the SMSR of Fig. 5c will drop to 5 and 26.5 dB at the 14 and 22 °C, respectively. According to the measured

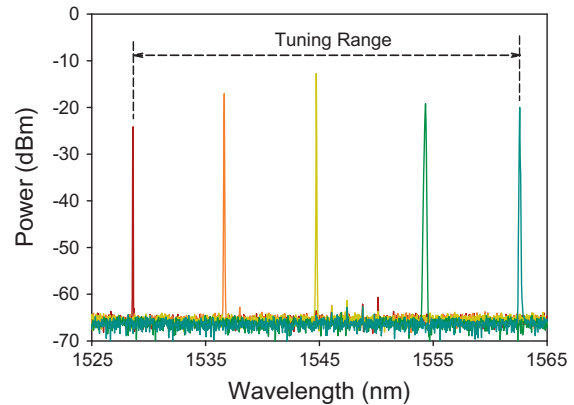

Fig. 3. Output spectra of the proposed wavelength-tunable laser in the tuning range of 1528.6–1562.6 nm with 1.4 nm tuning step.

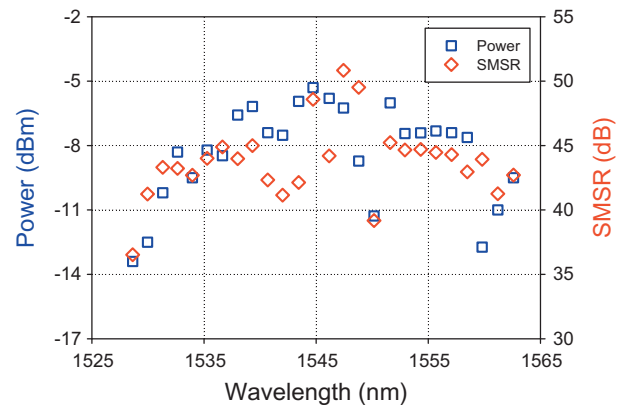

Fig. 4. Output power and SMSR versus different lasing wavelength of the proposed fiber coupled laser with the tuning step of 1.4 nm.

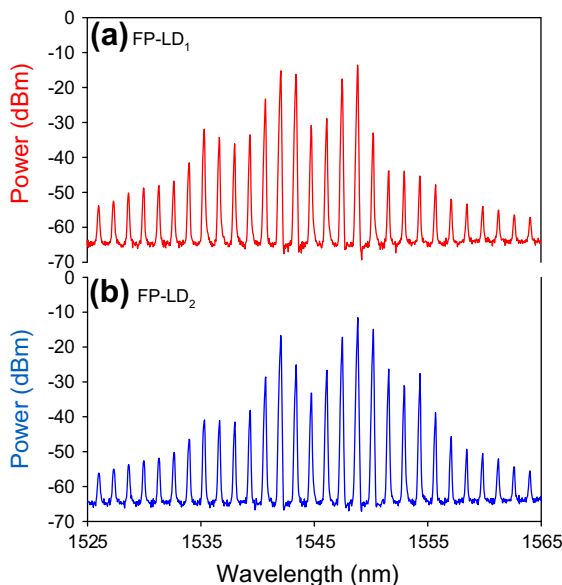

Fig. 2. Original output spectrum of FP-LD₁ and FP-LD₂ used in the proposed fiber coupled laser without inter-injection operation. The operating bias current and temperature of FP-LD₁ and FP-LD₂ are 21 mA and 18 °C and 22 mA and 25 °C, respectively.

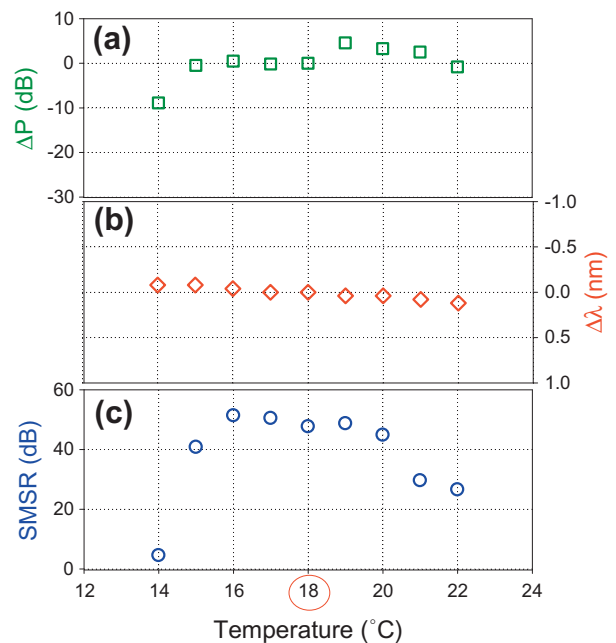

Fig. 5. (a) Output power variations, (b) central wavelength difference, and (c) SMSR of the proposed laser under different temperature on FP-LD₁ from 14 to 22 °C, respectively.

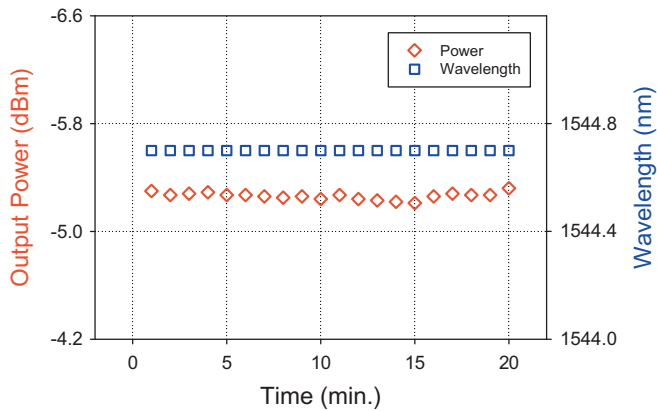

Fig. 6. The wavelength variation and the power fluctuation for the proposed fiber coupled laser when the lasing wavelength of the laser is 1544.7 nm initially with -5.3 dBm output power and the observation time is over 20 min.

results, when the $\Delta T = \pm 8$ °C, the lasing wavelength could be tuned in 0.16 nm range. Thus, this laser could be continuously tunable by controlling the temperature of FP-LDs.

In order to demonstrate the stabilities of the output power and wavelength of the proposed laser, a short-term measurement is performed, as illustrated in Fig. 6. Initially, the lasing wavelength of the laser is 1544.7 nm with -5.3 dBm output power and the observation time is over 20 min. In Fig. 6, the wavelength variation and the power fluctuation for the proposed fiber coupled laser are zero and 0.12 dB, respectively. During 1 h observation, the stable output of the proposed laser is still maintained. As a result, the proposed tunable laser has the advantages of simple scheme, cost-effective, stable and having a broad wavelength tuning range.

3. Conclusions

We have experimentally demonstrated a simple fiber coupled laser architecture to generate stable and tunable single-longitudi-

nal-mode wavelength based on a pair FP-LDs using inter-injection. By adjusting the tunable filter inside the laser cavity to align the corresponding mode of FP-LDs, the lasing wavelength can be tuned in the wavelength range of 1528.6–1562.2 nm with 1.4 nm tuning step. In this experiment, the maximum and minimum output power and SMSR are -5.3 and -13.4 dBm and 36.5 and 50.8 dB, respectively, over the tuning wavelength range. In the observation time of over 20 min, the wavelength variation and the power fluctuation for the proposed fiber coupled laser are zero and 0.12 dB, respectively. In addition, when the $\Delta T = \pm 8$ °C, the lasing wavelength is tuned in 0.16 nm range. Thus, this laser could be continuously tunable by controlling the temperature of FP-LDs.

References

- [1] P.J. Rigole, S. Nilsson, L. Backbom, B. Staltnacke, T. Klinga, E. Berling, B. Stoltz, D.J. Blumenthal, M. Shell, Wavelength coverage over 67 nm with GCSR laser. Tuning characteristics and switching speed, in: Int. Semiconductor Laser Conf. (ISLC'96), 1996, pp. 125–126.
- [2] V. Jayaraman, Z.-M. Chuang, L.A. Coldren, Theory, design, and performance of extended tuning range semiconductor lasers with sampled gratings, IEEE J. Quant. Electron. 29 (1993) 1824–1834.
- [3] P.J. Rigole, S. Nilsson, L. Bäckbom, T. Klinga, J. Wallin, B. Stålnacke, E. Berglind, B. Stoltz, 114-nm wavelength tuning range of a vertical grating assisted codirectional coupler laser with a super structure grating distributed Bragg reflector, IEEE Photon. Technol. Lett. 7 (1995) 697–699.
- [4] H. Ishii, H. Tanobe, F. Kano, Y. Tohmori, Y. Kondo, Y. Yoshikuni, Broad-range wavelength coverage (62.4 nm) with superstructure-grating DBR laser, Electron. Lett. 32 (1996) 454–455.
- [5] S.-M. Lee, K.-M. Choi, S.-G. Mun, J.-H. Moon, C.-H. Lee, Dense WDM-PON based on wavelength-locked Fabry–Perot laser diodes, IEEE Photon. Technol. Lett. 17 (2005) 1579–1581.
- [6] C.H. Yeh, F.Y. Shih, C.H. Wang, C.W. Chow, S. Chi, Cost-effective wavelength-tunable fiber laser using self-seeding Fabry–Perot laser diode, Opt. Exp. 16 (2008) 435–439.
- [7] S.K. Mondal, B. Roycroft, P. Lambkin, F. Peters, B. Corbett, P. Townsend, A. Ellis, A multi-wavelength low-power wavelength-locked slotted Fabry–Perot laser source for WDM applications, IEEE Photon. Technol. Lett. 19 (10) (2007) 744–746.
- [8] L.Y. Chan, C.K. Chan, D.T.K. Tong, F. Tong, L.K. Chen, Upstream traffic transmitter using injection-locked Fabry–Perot laser diode as modulator for WDM access networks, Electron. Lett. 38 (1) (2002) 43–44.