

This article was downloaded by: [National Chiao Tung University 國立交通大學]
On: 28 April 2014, At: 11:02
Publisher: Taylor & Francis
Informa Ltd Registered in England and Wales Registered Number: 1072954
Registered office: Mortimer House, 37-41 Mortimer Street, London W1T 3JH, UK



Journal of Modern Optics

Publication details, including instructions for authors and subscription information:

<http://www.tandfonline.com/loi/tmop20>

The Optical Signal Generator and Phase-locked Loop Based on a Triangularly Phase-modulated Fibre-optic Gyroscope

Pie-Yau Chien^a & Ci-Ling Pan^a

^a Institute of Electro-Optical Engineering, National Chiao Tung University, 1001 Ta Hsueh Road, Hsinchu, 30050, Taiwan, Republic of China

Published online: 01 Mar 2007.

To cite this article: Pie-Yau Chien & Ci-Ling Pan (1992) The Optical Signal Generator and Phase-locked Loop Based on a Triangularly Phase-modulated Fibre-optic Gyroscope, Journal of Modern Optics, 39:5, 1117-1122, DOI: [10.1080/09500349214551121](https://doi.org/10.1080/09500349214551121)

To link to this article: <http://dx.doi.org/10.1080/09500349214551121>

PLEASE SCROLL DOWN FOR ARTICLE

Taylor & Francis makes every effort to ensure the accuracy of all the information (the "Content") contained in the publications on our platform. However, Taylor & Francis, our agents, and our licensors make no representations or warranties whatsoever as to the accuracy, completeness, or suitability for any purpose of the Content. Any opinions and views expressed in this publication are the opinions and views of the authors, and are not the views of or endorsed by Taylor & Francis. The accuracy of the Content should not be relied upon and should be independently verified with primary sources of information. Taylor and Francis shall not be liable for any losses, actions, claims, proceedings, demands, costs, expenses, damages, and other liabilities whatsoever or howsoever caused arising directly or indirectly in connection with, in relation to or arising out of the use of the Content.

This article may be used for research, teaching, and private study purposes. Any substantial or systematic reproduction, redistribution, reselling, loan, sub-licensing, systematic supply, or distribution in any form to anyone is expressly forbidden. Terms & Conditions of access and use can be found at <http://www.tandfonline.com/page/terms-and-conditions>

The optical signal generator and phase-locked loop based on a triangularly phase-modulated fibre-optic gyroscope

PIE-YAU CHIEN and CI-LING PAN

Institute of Electro-Optical Engineering,
National Chiao Tung University, 1001 Ta Hsueh Road,
Hsinchu, Taiwan 30050, Republic of China

(Received 19 November 1991)

Abstract. A novel optical signal generator with purely sinusoidal waveform output has been demonstrated by applying a triangular phase modulation waveform to a fibre-optic gyroscope (FOG). A frequency-multiplied output in the format of an optical signal could be generated. An optical-type electrical phase-locked-loop system based on the intensity-modulated light source and this triangularly phase-modulated FOG has also been demonstrated.

1. Introduction

Generating a frequency-multiplied output of a given signal is very important in the design of signal generators, such as frequency synthesizers. The basic method used to generate a frequency multiplier electrically is based on the phase-locked loop (PLL) [1]. A signal generator with its output in the optical format is of fundamental interest. It would be useful, for example, in the diagnosis of optical receivers. A laser diode with its injection current modulated by an electronic signal generator would provide an intensity-modulated optical signal. In this set-up, however, the laser diode only functions as an electric-to-optical (E/O) converter. Recently, the optical sideband generation method has been applied to stabilize the frequencies of a set of lasers [2, 3] and the electrical sideband generated in the interferometer has also been used to measure the response of the photodetector [4-6]. In these sideband generation methods, however, the output spectrum is not a purely sinusoidal waveform and any harmonic frequencies of the modulation signal are generated simultaneously. In this paper, we demonstrate for the first time a novel optical sinusoidal signal generator with frequency-multiplied output. This was realized with a triangularly phase-modulated fibre-optic gyroscope (FOG). The multiplicative factor can be chosen arbitrarily. An optical-type phase detector in an electrical PLL system was also demonstrated by using this experimental set-up. The basic idea of our approach is based on an important characteristic of the static FOG, namely that its path-length difference is intrinsically zero in the static case.

2. Basic principles

The basic operating principle of our method is as follows. Consider a triangular phase modulation signal $\phi(t)$ is applied to an integrated-optic-type phase modulator at one end of the fibre sensing. The FOG is in a static state. The output signal at an optical receiver can be expressed as [7, 8]

$$V_{\text{out}}(t) = GI_0 \{1 + \cos [\phi(t) - \phi(t - \tau) + \Delta\phi_b]\}, \quad (1)$$

where G is the conversion gain of the optical receiver, I_0 is the output intensity of the light source, $\Delta\phi_b$ is the residual phase bias in the static FOG and can be considered such that $\Delta\phi_b \approx 0$, τ is the time delay of the fibre loop and $\phi(t)$ is the applied phase modulation signal which can be expressed as

$$\phi(t) = \begin{cases} +\alpha t, \\ -\alpha t, \end{cases} \quad \text{for} \quad \begin{cases} -\frac{T_s}{2} < t < 0, \\ 0 < t < +\frac{T_s}{2}, \end{cases} \quad (2)$$

where α is the rate of change in the phase modulator and T_s is the period of the triangular waveform. If the period T_s of the triangular waveform is selected such that $\tau = T_s/2$, then the time-delay phase modulation effect $\phi_{\text{eff}}(t) = \phi(t) - \phi(t - \tau)$ in the FOG can be written as $\phi_{\text{eff}}(t) = 2\phi(t) = \pm 2\alpha t$. The polarity of the $\phi_{\text{eff}}(t)$ corresponds to the different slope of the triangular waveform. If the peak phase deviation of the triangular waveform is larger than π rad, we can consider that the interferometric signal is scanned linearly by a dual-slope ramp waveform and a beat frequency is generated. In this case, the output signal of an a.c.-coupling receiver can be written as

$$V_1(t) = GI_0 \cos(\omega_{\text{eff}} t), \quad -\frac{T_s}{2} < t < 0, \quad (3)$$

$$V_2(t) = GI_0 \cos(\omega_{\text{eff}} t), \quad 0 < t < +\frac{T_s}{2}, \quad (4)$$

where the magnitude of the angular frequency ω_{eff} depends on the rate change α in the triangular waveform. If the α value is selected by changing the amplitude of the triangular waveform, one can obtain such that the period of beat frequency is the integer number of the triangular waveform, for example $\tau_{\text{eff}} = 2\pi/\omega_{\text{eff}} = nT_s/2$. The signals of $V_1(t)$ and $V_2(t)$ are continuous in the time domain. In other words, the output signal of the photodetector, which can be considered as $V_{\text{out}}(t) = V_1(t) + V_2(t)$, is a purely sinusoidal waveform. The frequency of this optically generated signal is an integral number of the triangular waveform.

Now, we attempt to consider the next application of this configuration. If the intensity of the light source is modulated by a second signal $\varepsilon \cos(\omega_2 t)$, the condition of purely sinusoidal waveform generation is also satisfied. The output signal at the optical receiver of a static FOG can be expressed as [7, 8]

$$V_{\text{out}}(t) = GI_0 [1 + \varepsilon \cos(\omega_2 t + \theta_T)] [1 + \cos(\omega_{\text{eff}} t + \theta_R)], \quad (5)$$

where θ_T is the phase of the intensity modulation signal at ω_2 , and θ_R is the phase at the beat frequency at ω_{eff} . If the d.c. offset term in equation (5) has been subtracted, an output signal of an optical-type phase detector operated at a frequency $\omega_{\text{eff}} = \omega_2$ is observed. Its output signal can be expressed as

$$V_{\text{PD}} = \frac{1}{2} GI_0 \varepsilon \sin \theta_e, \quad (6)$$

where $\theta_e = \theta_T - \theta_R$. By examining equations (3)–(6), we have the following interesting results.

- (1) The triangular phase-modulated FOG can be considered as a waveform converter from a triangular waveform to a purely sinusoidal waveform. It can also be considered as a frequency multiplier.

- (2) If we consider the signal generator at ω_2 to be the target oscillator, equation (6) describes an optical-type phase detector. The transfer function of the phase detector is the same as that of the conventional electrical mixer.
- (3) Since the phase detector is operated in the optical domain, this novel PLL exhibits a wide dynamic range. The maximum operating frequency of the system is limited by the frequency response of the phase modulator and the dynamic characteristic of the laser diode.

3. Experimental set-up

A schematic diagram of our experimental set-up is shown in figure 1. Nominally 3 dB fibre couplers are used. The gyroscope was formed using a polarization-maintaining fibre coil 12 cm in diameter. A commercial integrated-optic E-O phase modulator, produced by Crystal Technology Co., was used as the phase modulator in the FOG. This device is fabricated using LiNbO_3 with a fibre-pigtailed output, $V_\pi = 3 \text{ V}$, $f_{3\text{dB}} \geq 3 \text{ GHz}$. In our system, the V_π of the device will limit the maximum multiple number; thus a smaller V_π will be more suitable for this design. A superluminescent laser diode source of wavelength $\lambda = 0.83 \mu\text{m}$ with fibre-pigtailed output (Laser Diode Co.) was adopted as the light source. The temperature and driving current of the laser diode were stabilized to $\Delta T \leq 1.0 \times 10^{-3} \text{ }^\circ\text{C}$ and $\Delta i \leq 1.0 \mu\text{A}$ respectively. Thus I_0 was stabilized to $\Delta I_0/I_0 \leq 1.0 \times 10^{-4}$.

Two experiments were carried out using this experimental set-up. In the first experiment, a triangular waveform of frequency at 1.0 MHz with $T_s = 2\tau$ was applied to the integrated-optic (I-O) phase modulator. By adjusting the amplitude of the triangular waveform so that the corresponding phase deviation of the I-O phase modulator was equal to the integer number of π rad, then an optically purely sinusoidal waveform was generated. The output signal of the FOG was shown in figure 2(a) for a phase deviation of 2π rad and figure 2(b) for a phase deviation of 6π rad. The corresponding frequencies of 2.0 and 6.0 MHz sinusoidal waveform were obtained. The spectrum of the 6.0 MHz beat signal is shown in figure 3. A sideband suppression of 45 dB was observed.

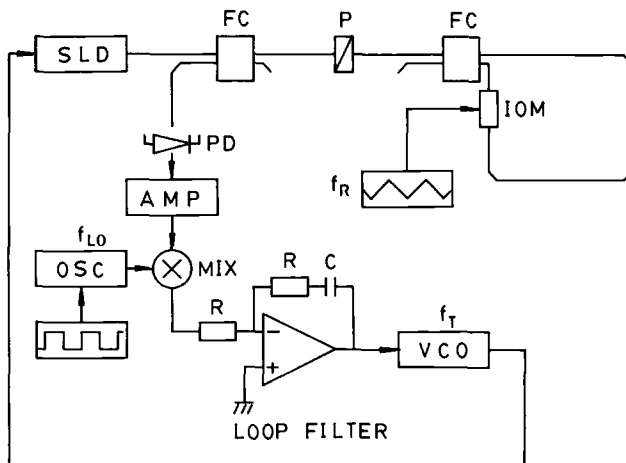
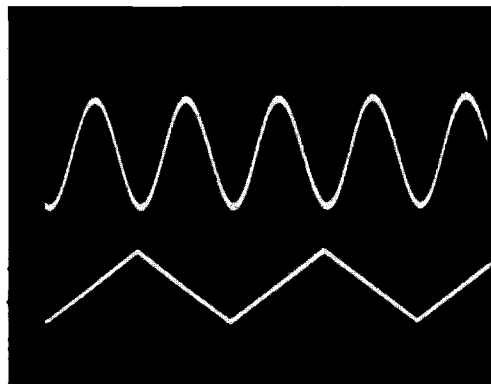
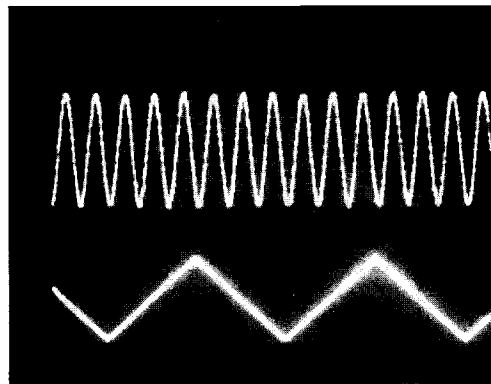

Figure 1. Experimental set-up of the optical signal generator and the optical-type electrical PLL system: SLD, superluminescent laser diode; OSC, oscillator; MIX, mixer; PD, photodetector; AMP, amplifier; R, resistor; C, capacitor; FC, fibre coupler; P, polarizer; IOM, integrated-optic phase modulator; VCO, voltage-controlled oscillator.



(a)



(b)

Figure 2. The waveform converter effect from the applied triangular waveform to sinusoidal waveform: (a) multiplicative factor of 2.0; (b) multiplicative factor of 6.0. The lower trace is the applied triangular waveform. The upper trace is the output sinusoidal waveform.

In the second experiment, we attempted to demonstrate the optical-type PLL system. In this experiment, the 1.0 MHz triangular waveform was used as the reference signal. To demonstrate the phase locking, a 6.0 MHz voltage-controlled oscillator modulating the driving current of the laser diode was used as the target oscillator. A 100 kHz oscillator was used as the offset local oscillator to mix the output signal of the optical receiver of the FOG for frequency-tracking performance testing. This was implemented by applying a 1.0 kHz square waveform to dither the frequency of the 100 kHz signal. A loop filter of the proportional and integrating (PI) type was used to implement the phase-tracking function of the PLL circuit. The natural frequency of the servo system was selected to be 10.0 kHz and the damping factor was designed to be 1.0 in the PI compensation circuit. Figure 4 illustrates the frequency-tracking performance of the PLL circuit when a 1.0 kHz dither signal was applied to modulate the 100 kHz signal and the response of the PLL circuit at the

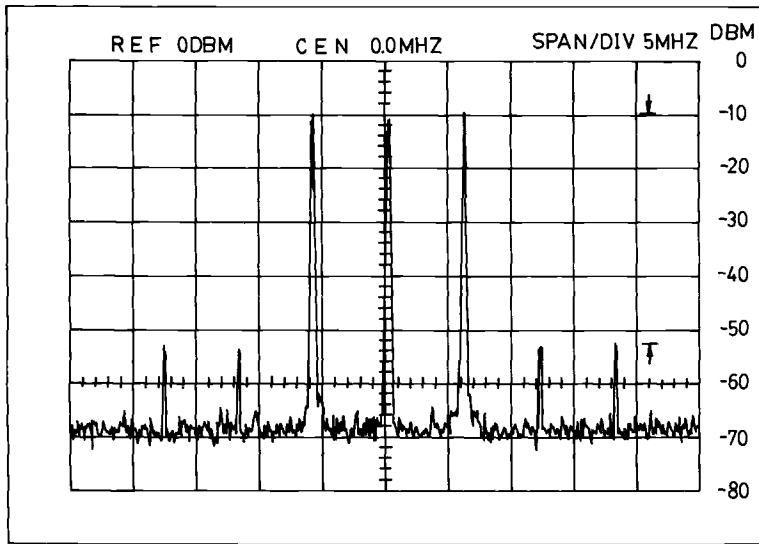

Figure 3. The output spectrum of the generated 6.0 MHz optical sinusoidal waveform.

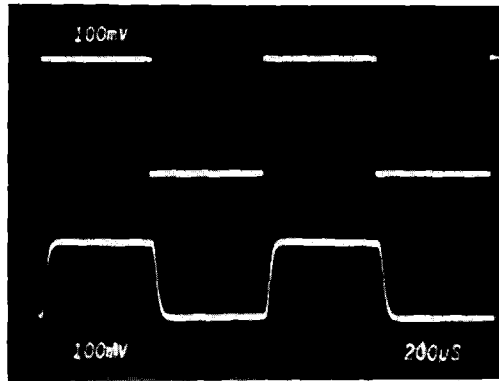

Figure 4. The tracking performance of the PLL system. The upper trace is the dither signal. The lower trace is the signal at the input of the voltage-controlled oscillator.

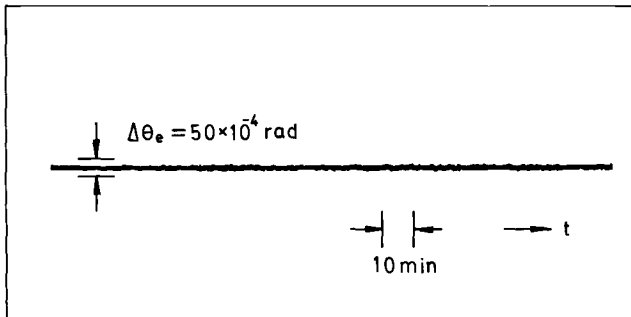

Figure 5. The phase error θ_e of the PLL system under the condition that the phase was locked.

Downloaded by [National Chiao Tung University] at 11:02 28 April 2014

output of the loop filter. An excellent tracking capability was achieved. The tracking time was about 0.1 ms. The target oscillator was thus locked at 6.0 ± 0.1 MHz. The phase error of the PLL circuit at the input of the loop filter was stabilized to $\Delta\theta_e \leq 2.0 \times 10^{-4}$ rad with a measurement bandwidth of 10.0 Hz.

4. Conclusions

In summary, we have demonstrated a novel optical signal generator with a frequency-multiplied output. This was accomplished by using a triangularly phase-modulated FOG in the static state. The multiplicative factor was limited by the maximum phase deviation allowed in the I-O phase modulator. The sideband suppression is limited by the linearity of slope of the triangular waveform and its amplitude stability. It can be improved by employing a stabilized current source to charge a precision capacitor and an amplitude-stabilized circuit respectively.

An interferometric phase locking of two electronic oscillators at 1.0 and 6.0 MHz with an intensity-modulated laser diode and a static phase-modulated FOG has also been demonstrated. The tracking time was about 0.1 ms and the phase error was less than 6.0×10^{-5} rad Hz^{-1/2}. This novel optical-type PLL design can in principle be extended to the gigahertz region and beyond.

Acknowledgments

This work was partially supported by the National Science Council of the Republic of China under Grant No. NSC-80-0417-E-009-05.

References

- [1] GARDNER, F. M., 1979, *Phaselock Technique* (New York: Wiley).
- [2] MAEDA, M. W., and KAZOVSKY, L. G., 1989, *IEEE Photon. Technol. Lett.*, **1**, 455.
- [3] KAZOVSKY, L. G., and JENSEN, B., 1990, *IEEE Photon. Technol. Lett.*, **2**, 526.
- [4] EICHEN, E., and SILLETI, A., 1987, *IEEE J. Lightwave Technol.*, **LT-5**, 1377.
- [5] HEMERY, E., CHUSSEAU, L., and LOURTIOZ, J. M., 1989, *Electron. Lett.*, **25**, 42.
- [6] WANG, J., KRUGER, U., SCHWARZ, B., and PERTERMANN, K., 1989, *Electron. Lett.*, **25**, 722.
- [7] PAVLATH, G. A., and SHAW, H. J., 1982, *Appl. Optics*, **21**, 1752.
- [8] BERGH, R. A., LEFEVRE, H. C., and SHAW, H. J., 1981, *Optics Lett.*, **6**, 502.