

# Deep Phase-Modulation Approach to an Open-Loop Fiber Optic Gyroscope

Pie-Yau Chien and Ci-Ling Pan

**Abstract**—A new approach to an open-loop, all-fiber gyroscope with wide dynamic range and linear scale factor is described. For signal processing, the Sagnac phase lift is converted into a phase shift in the low-frequency electrical signal by using a deep sinusoidal phase-modulation waveform followed by gate-switching. With the duty cycle of the gating signal selected to be in the range between 20 and 70%, the scale factor is stable with respect to change in the amplitude of the phase modulation signal by as much as 15%. The basic principle of this technique and experimental results are reported.

IN the early stage of the development of fiber-optic gyroscopes (FOG), fundamental problems such as sensitivity and bias stability had been solved by using light sources with short coherence lengths, e.g., superluminescent laser diodes or SLD's [1]–[3] and polarization-maintaining fibers [4], [5]. A noise equivalent rotation rate of about  $0.1^\circ/\text{h}$  and bias stability of better than  $0.1^\circ/\text{h}$  have been achieved. Later on, various signal processing schemes [6]–[16] were developed to realize FOG's with linear scale factor, wide dynamic range, and immunity to fluctuations in light intensity. There are two primary approaches to signal processing for FOG's. In open-loop FOG's, a sinusoidal phase modulator utilizing the elasto-optic effect with lock-in detection is often used [6]. Alternatively, the optical phase is transformed into the phase shift of a low-frequency electrical carrier by the pseudo-heterodyne scheme [7], [8] or phase-modulated single-sideband detection scheme [9]. In the close-loop configuration, FOG's employ nonreciprocal phase shift devices in a feedback loop to compensate the Sagnac phase shift. Faraday rotators [10], acousto-optic modulators [11], integrated optic serrodyne modulators [12], [13], and gate-phase modulators [14]–[16] have been used as nonreciprocal devices. In these methods, the employment of an integrated-optic frequency translator in either the open- or closed-loop configuration may be the most promising approach. Unfortunately, the integrated optic phase modulator still exhibits large insertion losses and are not widely available. As a result, the piezoelectric phase modulators remain extensively used in open-loop type FOG's at the present time. For signal processing, the pseudo-heterodyne detection method is often employed to achieve the wide dynamic range and linearity in the scale factor. In this scheme, the ratio of the second- and fourth-harmonic components of the phase modulation signal is adjusted to maintain the modulation amplitude at  $J_2(k)/J_4(k) = 4.39$  where  $k = 2.82$ . In this letter we demonstrate a new signal processing method for open-loop FOG's. It is achieved by applying a deep phase modulation waveform to a piezoelectric transducer employed in the FOG. The peak phase

Manuscript received October 9, 1990; revised December 17, 1990. This work was supported in part by the National Science Council of the Republic of China.

The authors are with the Institute of Electro-Optical Engineering, National Chiao-Tung University, Hsinchu, Taiwan 30050, Republic of China.  
IEEE Log Number 9143141.

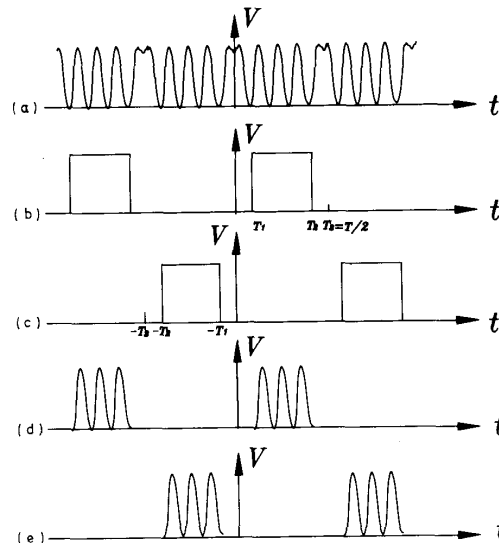

Fig. 1. Graphic illustration of the basic principles of our phase-reading method. (a) signal output at the detector; (b) and (c) are gate switching waveforms to separate the signal into two channels; (d) and (e) are gated signals feeding into the PLL circuits.

deviation is adjusted to be much larger than  $\pi$ . By using this method, one need not stabilize the amplitude of the modulation signal such that the peak phase deviation is 2.82 rad exactly. The Sagnac phase shift is derived from the phase of the low-frequency electrical signal.

The basic operating principle of our method is as following: rotation of the gyroscope creates an unbalanced Sagnac phase shift of  $\Delta\phi_R$  between counterpropagating beams. The phase shift is proportional to the rotation rate. A deep phase sinusoidal waveform is employed as the phase modulation signal. This moves the operating point off the central peak of the interference fringe. As a result, the effective peak phase deviation of the interference signal of the gyro  $\Delta\phi_m$  is much larger than  $\pi$ . The detected photocurrent  $I(t)$  of an open-loop gyroscope can then be expressed as

$$I(t) = C[1 + \cos \Delta\phi_{\text{tot}}] \\ = C[1 + \cos(\Delta\phi_m \sin \omega_m t - \Delta\phi_R)]. \quad (1)$$

Here  $C$  is a constant;  $\Delta\phi_m = 2\phi_m \sin \omega\tau/2$  is the magnitude of the phase difference between the counterpropagating waves produced by the modulation;  $\tau$  is the time delay of the fiber loop and  $\omega_m = 2\pi f_m$ . Under the condition of  $\Delta\phi_m \gg \pi$ , the sinusoidal waveform of the phase modulation signal can be approximated by the triangular waveform within some effective periods.

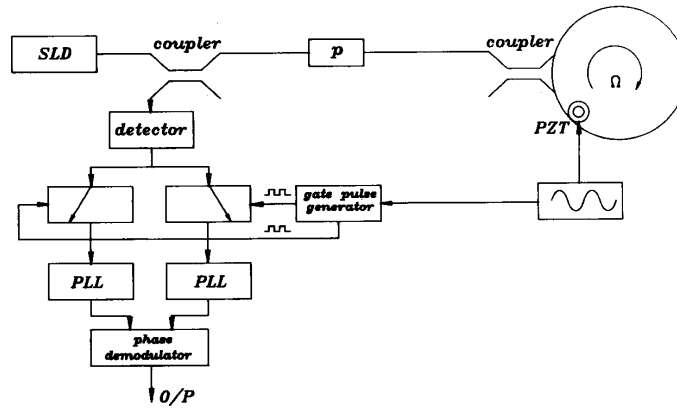

Fig. 2. Block diagram of the experimental setup. SLD: superluminescent diodes; P: polarizer; PLL: phase lock loop circuit.

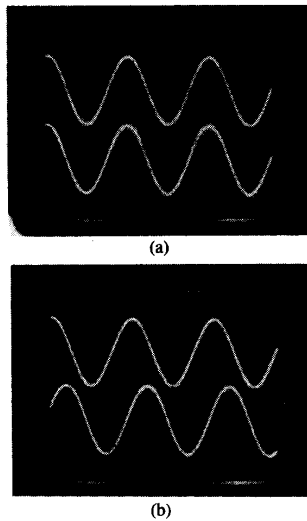

Fig. 3. Signal output of the PLL. Upper trace, channel 1. Lower trace, channel 2. (a) Output at the PLL bandpass-filter when  $2\Delta\phi_R = 0$ . (b) Output at the PLL bandpass-filter when  $2\Delta\phi_R = 60^\circ$  where  $\Omega = 15$  deg/sec.

In this effectively linearly phase-modulated region, the output signal can be expressed as

$$I_1(t) = K \cos(\omega_{\text{eff}} t + \Delta\phi_R), -T_2 < t < -T_1 \quad (2a)$$

and

$$I_2(t) = K \cos(\omega_{\text{eff}} t - \Delta\phi_R), T_1 < t < T_2. \quad (2b)$$

Linear sweep of the optical phase by the modulation waveform results in an effective beating frequency of  $\omega_{\text{eff}} = n2\pi/T_{\text{eff}}$  where  $T_{\text{eff}} = |T_1 - T_2|$ . The value of  $\omega_{\text{eff}}$  can in principle be any integral harmonics of the modulation frequency, depending on the modulation amplitude. Fig. 1 shows the basic principle underlying the above discussions. From (2a) and (2b), one immediately see that a measurement of the phase difference of  $I_1$  and  $I_2$  in the first half of the effective period, from  $-T_2$  to  $-T_1$ , and in the second half of the effective period, from  $T_1$  to  $T_2$ , yields  $2\Delta\phi_R$ , twice the Sagnac phase shift. Within the effective period, the deep sinusoidal phase-modulation waveform can be expressed as an effective triangular phase-modulation

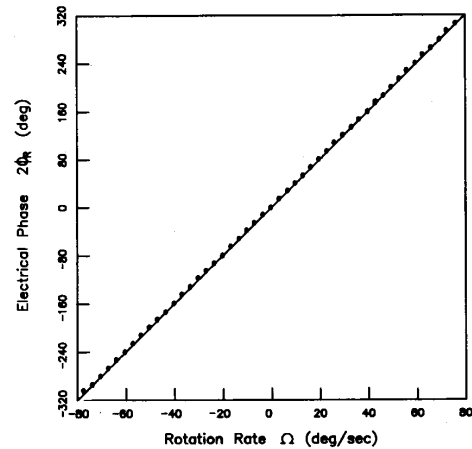

Fig. 4. Experimental results of the output signal of the FOG as a function of the rotation rate.

waveform. By using this technique, the nonlinear dependence of the amplitude term of the output signal associated with the deep sinusoidal phase modulation waveform can be removed by proper adjustment of the time interval of the gate. The adjustment criteria will be discussed in a later paragraph. The amplitude noise due to the power and modulation index instability of the laser diode is isolated from the phase term by utilizing the phase lock loop tracker or a zero-crossing comparator.

A block diagram of the experimental arrangement of our FOG is shown in Fig. 2. Nominally, 3 dB fiber couplers are used. The gyroscope was formed using polarization-maintaining fiber coils 12 cm in diameter. The fiber length was selected such that the scale factor of our gyroscope was  $\Delta\phi_R = 2.0 \Omega$  where  $\Omega$  is the rotation rate of the gyroscope. A superluminescent laser diode (SLD) [Laser Diode Inc. SRD-8302-PPF] employed as the light source to reduce noise. An in-line piezoelectric transducer (PZT) with several turns of fiber wrapped around it was used as the phase modulator. A 8 kHz sinusoidal waveform was applied to the PZT. The amplitude of the modulation waveform was adjusted such that  $\omega_{\text{eff}}$  was at 80 kHz. The signal output of the gyroscope was then gate-switched by an analog switch with proper gating time interval. The selection of the gating time interval was influenced by the peak amplitude of the phase

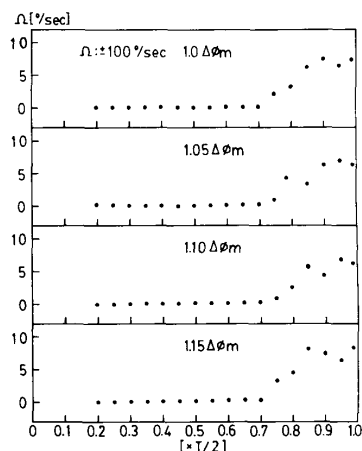

Fig. 5. Experiment results of the scale factor stability influenced by the amplitude of the phase modulation signal and the duty cycle of the gating pulse width.  $x$  axis is the duty cycle of the gating signal, the unit is the half period ( $T/2$ ) of the phase modulation signal.  $y$  axis is the equivalent rotating error in the scale factor.

modulation signal. There are two criteria for optimum choice of the width of ( $T_2 - T_1$ ): 1) the modulation index of the phase modulator need to be large enough such that within the gated time interval, the signal can be separated from the gating signal by the phase-lock-loop tracker. 2) The duty cycle need be adjusted such that the amplitude information in the nonlinear region of the sinusoidal signal was eliminated. For the experiment reported here, the duty cycle of the gated time interval in our system is selected to be less than 70% of the half period of the modulation signal. It is easy to check by rotating the gyroscope that the information on the rotation rate was included in the phase of the angular frequency  $\omega_{\text{eff}}$  only. The phase detection scheme is also advantageous because the scale factor would also be quite stable (see Figs. 3 and 4). In comparison, the adjustment needed in this approach were not as stringent as those required in the conventional pseudo-heterodyne detection technique.

The two gated signals were fed into separate channels followed by bandpass filters constructed using the phase-lock-loop (PLL) circuits. The output signals of the two channels after the PLL were shown in Fig. 3(a) and (b) for the rotation rate of  $\Omega = 0^\circ/\text{sec}$  and  $\Omega = 15^\circ/\text{sec}$  respectively. From Fig. 3, we can deduce that  $2\phi_R = 4\Omega = 60^\circ$ , consistent with our theoretical prediction given in (2). Fig. 4 showed the measured phase shift at the filter output as a function of the rotation rate of the fiber gyroscope. The experimental results show that a good linearity over a wide dynamic range is obtained.

The scale factor stability achieved by this method is affected by the pulse width of gating signal. This was illustrated in Fig. (5). In this experiment, we have arbitrarily chosen the amplitude of phase modulation index such that an offset to the optimum value for the pseudo-heterodyne processing method was present while the deep-phase-modulation-index condition was satisfied. The test range of the FOG to measure the scale factor stability was  $\pm 100^\circ/\text{s}$ . When the pulse width of the gating signal was in the range of 20–70% of the half period of the phase modulation

signal, we found that the equivalent rotating rate error in the scale factor was less than  $0.5^\circ/\text{s}$  for change in the amplitude of the phase modulation signal by as much as 15%. The nonlinear portion of the sinusoidal waveform on the phase modulation signal would be gated in if the duty cycle of the gating signal was larger than 70%. As a result, a large scale factor error was generated. The lower limit of the duty cycle was chosen such that approximately ten cycles of the beat frequency was present in the gated interval. This is primarily for ease in signal processing.

In summary, a deep-phase-modulated open-loop operation of a fiber-optic gyroscope was demonstrated. The FOG exhibits wide dynamic range with a linear scale-factor. With the duty cycle of the gating signal selected to be in the range between 20 and 70%, the scale factor was stable for change in the amplitude of the phase modulation signal by as much as 15%. This is in sharp contrast to the pseudo-heterodyne detection scheme in which the requirement on the exact value of the phase modulation amplitude is quite stringent.

#### REFERENCES

- [1] H. C. Lefevre, R. A. Bergh, and H. J. Shaw, "All-fiber gyroscope with inertial navigation short-term sensitivity," *Opt. Lett.*, vol. 7, pp. 454–456, 1982.
- [2] W. K. Burn, C. L. Chen, and R. P. Moeller, "Fiber-optic gyroscope with broadband sources," *J. Lightwave Technol.*, vol. LT-1, pp. 98–105, 1983.
- [3] W. K. Burn and R. P. Moeller, "Rayleigh backscattering in a fiber gyroscope with limited coherence sources," *J. Lightwave Technol.*, vol. LT-1, pp. 381–386, 1983.
- [4] W. K. Burn, R. P. Moeller, C. A. Villarruel, and M. Abebe, "Fiber-optic gyroscope with polarization-holding fiber," *Opt. Lett.*, vol. 8, pp. 540–542, 1983.
- [5] R. A. Bergh, H. C. Lefevre, and H. J. Shaw, "All-single-mode fiber-optic gyroscope with long term stability," *Opt. Lett.*, vol. 6, pp. 502–504, 1981.
- [6] K. Bohm, P. Marten, K. Petermann, and E. Weidel, "Direct rotation-rate detection with a fiber-optic gyro by using digital data processing," *Electron. Lett.*, vol. 19, pp. 997–999, 1983.
- [7] A. D. Kersey, A. C. Lewin, and D. A. Jackson, "Pseudo-heterodyne detection scheme for the fiber gyroscope," *Electron Lett.*, vol. 20, pp. 368–370, 1984.
- [8] B. Y. Kim and H. J. Shaw, "Phase-reading, all-fiber-optic gyroscope," *Opt. Lett.*, vol. 9, pp. 378–380, 1984.
- [9] D. Eberhard and E. Voges, "Fiber gyroscope with phase-modulated single-sideband detection," *Opt. Lett.*, vol. 9, pp. 22–24, 1984.
- [10] W. C. Davis, W. L. Pondrom, and D. E. Thompson, "Fiber optic gyro using magneto-optic phase nulling feedback," in *Fiber-Optic Rotation Sensors and Related Technologies*, S. Ezekiel and H. J. Arditty, Eds. New York, Springer Verlag, 1982, pp. 308–315.
- [11] J. L. Davis and S. Ezekiel, "Closed-loop, low-noise fiber-optic rotation sensor," *Opt. Lett.*, vol. 6, pp. 505–507, 1981.
- [12] A. Ebberg and G. Schiffner, "Close-loop fiber-optic gyroscope with a sawtooth phase-modulated feedback," *Opt. Lett.*, vol. 10, pp. 300–302, 1985.
- [13] C. J. Kay, "Serrrodyne modulator in a fiber-optic gyroscope," *IEEE Proc.*, vol. 132, pp. 259–264, 1985.
- [14] B. Y. Kim and H. J. Shaw, "Gate phase-modulation feedback approach to fiber-optic gyroscopes," *Opt. Lett.*, pp. 263–265, 1984.
- [15] —, "Gated phase-modulation approach to fiber-optic gyroscope with linearized scale factor," *Opt. Lett.*, vol. 9, pp. 375–377, 1984.
- [16] M. Oh and Y. Kim, "Open-loop fiber-optic gyroscope using intensity-modulated source and phase modulation," *Opt. Lett.*, vol. 13, pp. 521–523, 1988.