

國立交通大學
建築研究所
碩士論文

再符號

Re-symbolization – Tectonic Imagination

研究生：林侑萱

指導教授：張基義

中華民國九十八年七月



RE-SYMBOLIZATION -TECTONIC

200709-200906

林侑萱 YU-HSUAN LIN, NCTU



Contents

- 03 Preface
- 04 Abstract
- 07 Symb-reading2.0
Transitional Shelves Library
Permutation & Combination of 0&1
- 23 Symb-deconstruction of historic space
Anchoring
Museum of Taipei City
- 39 Symbolization of tectonic materials
Urban Subconscious
Practice of Self-dwelling
- 63 Vertical symbolic of Specific Community
Embedded Richness
Vertical Village of Street-house

C IMAGINATION



PREFACE

Man is a "symbolic animal". Whereas animals perceive their world by instincts and direct sensory perception, man has created his own universe of symbolic meaning that structures and shapes his perception of reality - and only thus, for instance, can conceive of utopias and therefore progress in the form of shared human culture. For Cassirer, the human world is created through symbolic forms of thought which are linguistic, scholarly, scientific, and artistic, sharing and extending through communication, individual understanding, discovery and expression.

-Says Cassirer later in his more popular *Essay on Man* (1944)



ABSTRACT

> 識別/符號

識別，譯自英文的identity，意指個人如何認知到自己是不同於別人的獨特個體。identity的成形，是來自於人對意義感有不斷探索的渴求，過程當中所凝聚出來的自我想像，會藉由各種抽象與具體的手段，對外（也對自己）宣示存在的價值。

德國哲學家卡西爾（Ernst Cassirer）提出--人其實是「符號的動物」，因為人是唯一能「創造」與「使用」符號的物種，透過語言、科學、宗教等人為（man-made）符號系統，我們理解與掌握世界，創造了文明。在一種認知體系中，**符號**是指代一定意義的意象，可以是圖形圖像、文字組合，也不妨是聲音信號、建築造型，甚至可以是一種思想文化、一個時事人物。**空間的識別**，顯然也是一種符號系統，它包含了文字、圖片、顏色、標誌等元素，每個元素之間有對應的結構關係，作為抽象意念表達的溝通媒介。

> 抽象-現實-表現

按Charles Peirce, Charles Morris兩者就符號學的分類：

- 1.圖像符號：建築的形式和內容存有著型似的關連（材料）
- 2.指示符號：建築的形式和內容存有著實質的因果（門窗）
- 3.象徵符號：建築的形式和內容建立起來的任意性關聯

此處的符號指的是象徵符號-Symbolic Representation，一種抽象概念的符號化與結構化；本研究分別就四個不同面向--行為、空間、感官、概念原型，於空間的識別上加入了自我的知覺、感官，以重新解釋/定義，並予以再符號re-symbolization的表現。

在Symb-reading2.0的部分再符號數位網路化下，人/書架/資訊之間的關係，透過Classify→Tag→Interact的動作，使用者的閱讀經驗亦成為圖書館「書架」上的一部分。Symb-deconstruction of historic space，就台北城發展的脈絡，錨定記憶與歷史於空間中的定位、城市發展與活動的關係；以一半閒置的歷史空間為舞臺進行解構、重構與再符號的台北城博物館。Symbolization of tectonic materials透過個人對構造材料的感官對原有的材料再符號，反應人對空間需求的潛意識並透過對材料的解讀架構空間書寫的「語法」，作為潛意識物化的工具；最後以自宅為設計操作的對象進行空間的實現。Vertical symbolic of specific community則以五條港區一個街屋類型的街廓作為社區原型，重新定義一村落地尺度的模型於高密度城市中的空間內涵與相對關係(repeogram)；依城市發展的趨勢，對此街屋類型發展的社區原型做垂直化的再符號。



ABSTRACT

>Identity/Symbol

Identity means how individuals perceive themselves as unique and different from others. Because human beings are constantly searching for their value, identity is simply a self-imagination during such process, where people declare their existence by any abstract or concrete means.

In fact Ernst Cassirer, a German philosopher stated that man is a "symbolic animal". Because they are the only species in the world capable of creating and using symbols through languages, science, religion and other man-made symbol system. By creating civilization, man understands and is able to grasp this world. In a cognitive system, symbol represents the image of things, which could be graphic images, composition of words, voice signals or construction styles. Moreover, it could also be ideological or cultural. In this sense, the identification of spaces is clearly a symbol system that includes texts, pictures, colors, logos and other elements. Each element responds to each other in order for man to communicate (or to express) their thoughts.

>Abstraction-Reality-Representation

According to Charles Peirce and Charles Morris, semiotic is classified as three categories:

1. Iconic Representation: a relationship between architectural forms and their concepts (material).
2. Analogical Representation: a causal relationship between architectural forms and their concepts (doors and windows).
3. Symbolic Representation: an arbitrary correlation established between architectural forms and their concepts.

The symbols here refer to the symbolic representations as symbolization and structures of abstract concepts. This paper is divided into four parts--activities, space, senses, and concept of space prototype by adding self-perception and sensory in identification of space to give re-interpretation / definition for re-symbolization.

"Symb-reading2.0"- it aims to re-symbolize the relationship between people, books and information through the action of "Classify→Tag→Interact" , which allows the reading experience to be parts of "shelves" in the library.

"Symb-deconstruction of historic space"- according to the development of Taipei City, this paper anchors the memory and history in space as well as the relationship between city development and activities, by taking a semi-idle place as a site to deconstruct, reconstruct and re-symbolize the Taipei City Museum.



"Symbolization of tectonic materials" talks about the re-symbolization of original materials by adding personal senses to them. Respond to the subconscious of space requirements, I want to create syntax for space writing through interpretation of materials. The final part takes practice of self-dwelling as the realization of space.

"Vertical symbolic of specific community"- deals with a street-house typology in Wu-Tiao Gang area as a community prototype to further redefine and reprogram the model of village scale positioned in the city. According to the trend of city development, vertical re-symbolizes this community prototype of street-house development.

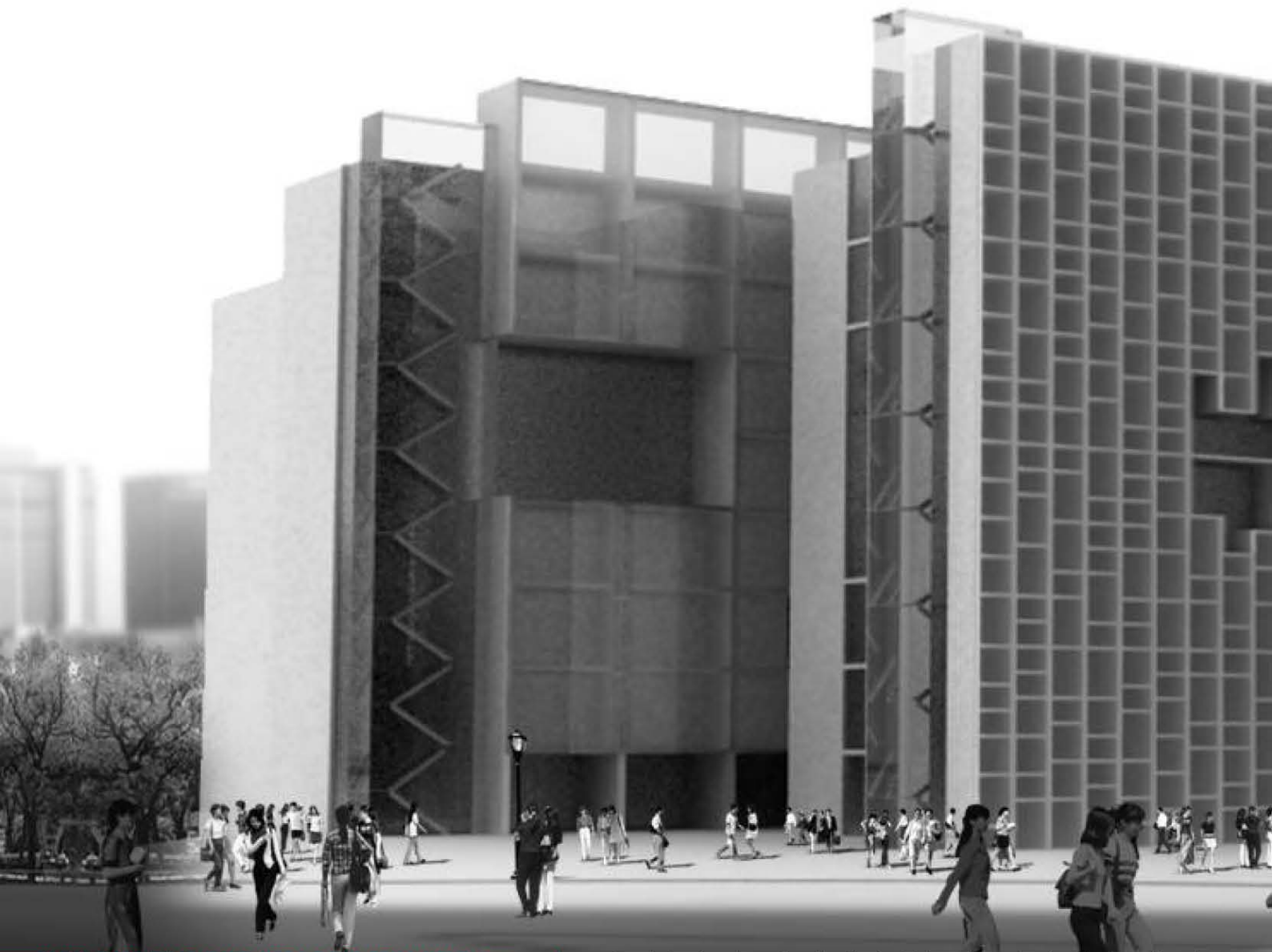

01 · TRANSITIONAL

200709-200801 PERMUTATION &

ADVISOR: SHU-CHANG KUNG/CHIH-KANG CHI



SHELVES LIBRARY

COMBINATION OF 0 & 1



OLD MEDIA LIBRARY

交流

圖書館與書在未來仍會存在的原因，除了閱讀與身體觸感關係互動的需要、舊書保存的需求外，最重要的是這種實質地點幫助知識交流，透過實質的身體觸感互動，產生各種領域的認知，不只是資訊的交流，還有待人接物、責任、肢體碰觸、全觀的體驗等。

舊媒體圖書館

本質

完整收藏資訊、具有高散播性、易親近三點是圖書館最基本也最傳統的使命。今天一年出版的新書就超過了過去40年出版品的數量，也幾乎相當於更早2000年時間所留下的書種數量，世界各國的國家圖書館館藏量都已數以千萬計，如此龐大的書庫，現代圖書館的空間語彙應該要轉變了，如何既分又合是設計重點。

氣氛

書和圖書館提供的是一種環境，一種氛圍，一種關係(context)。閱讀分成娛樂(如小說、漫畫)、參考(如字典、地圖)、知識(工作生活需要的常識)、思想(提升精神生活)四種等級，最高等級需要安靜的環境、特殊的氣氛。

閱讀

認知這個世界並能以新視野去看原世界，這是閱讀的意義。閱讀的形式並不限於文字，也可以是圖像、聲音、觸覺、味覺、嗅覺的閱讀，任何可以幫助我們認知這個世界的方式都是在閱讀。但是文字也因為其侷限性，反而提供我們無窮的想像空間。

21st Century Libraries

1. User Centered
2. Community Focused
3. Experience Driven
4. Innovative Formats
5. Destinations
6. Combined Resources
7. Focusing on Future Roles

Classify→Tag→Interact





OLD MEDIA

彈性

現代由於書的出版量極多，新建完成的圖書館總是需要不斷應付動態成長的館藏，因此現代的圖書館總是會要求空間具有相當程度的彈性，並提供未來增建的可能性。這對書或許是件好事，但是對於圖書館內的閱覽空間、公共空間、交流空間等等或許就不是件好事了，沒有品質的閱覽空間，也會降低這個圖書館的吸引力，那麼豐富的館藏如果沒有讀者，那又如何？所以，現代圖書館的難題就在於，如何兼顧兩者，提出一個好的空間架構與計畫。

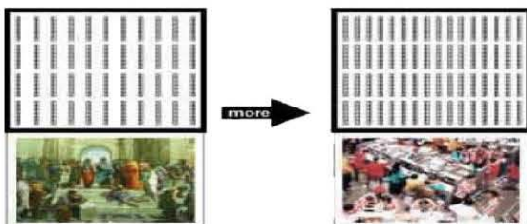
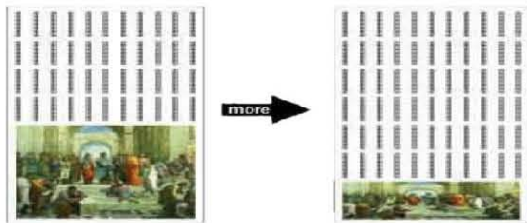

Books Media Services

> EVOLUTION OF READING NEW MEDIA-IN HYBRID TYPE

從100多年前開始，電影、收音機、電視等相繼進入我們的生活，這些新的媒體提供以其他感官來認知世界的可能，而網路更是注定要踏上一個顛覆文字的路程，在科技的輔助下，終將結合文字以外的觸感，提供一種全新的感官經驗與紀錄方式，人類得以重溫全觀認知。

零與一最簡單的重複，卻可以構成如此複雜的電腦語言，全世界正向著形勢上簡化物體的方向前進；向著形勢隱藏它本身功能的方向前進；未來的圖書館將扮演資訊仲介的角色。而建築空間也將成為一涵容所有閱讀行為關係的載體，組織與控制各種出入。

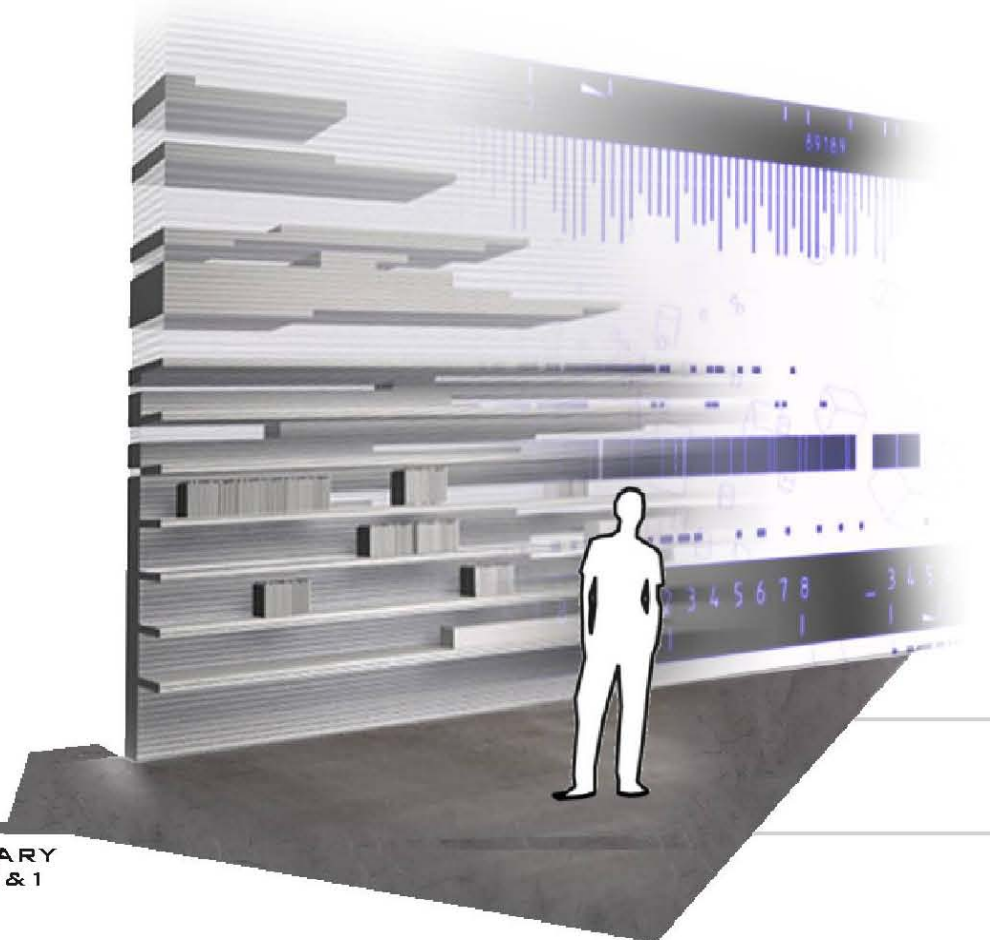

01-TRANSITIONAL SHELVES LIBRARY
PERMUTATION & COMBINATION OF 0&1

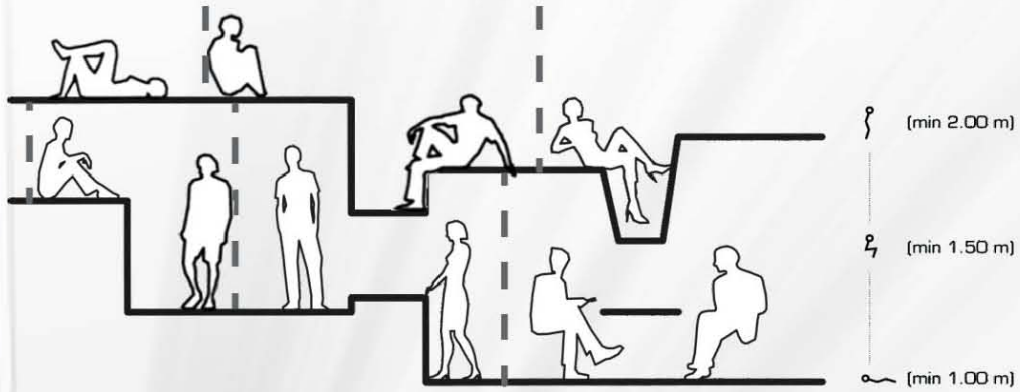

> ACTIVITY REPOSITORY





DYNAMIC FACADE

空間之形式為虛體與實體元素之相對關係所決定
虛體元素決定了空間的樣貌，而實體元素則決定了空間的邊界位置及特性
藉由型態上的實與虛，反應內部動態的「事件」

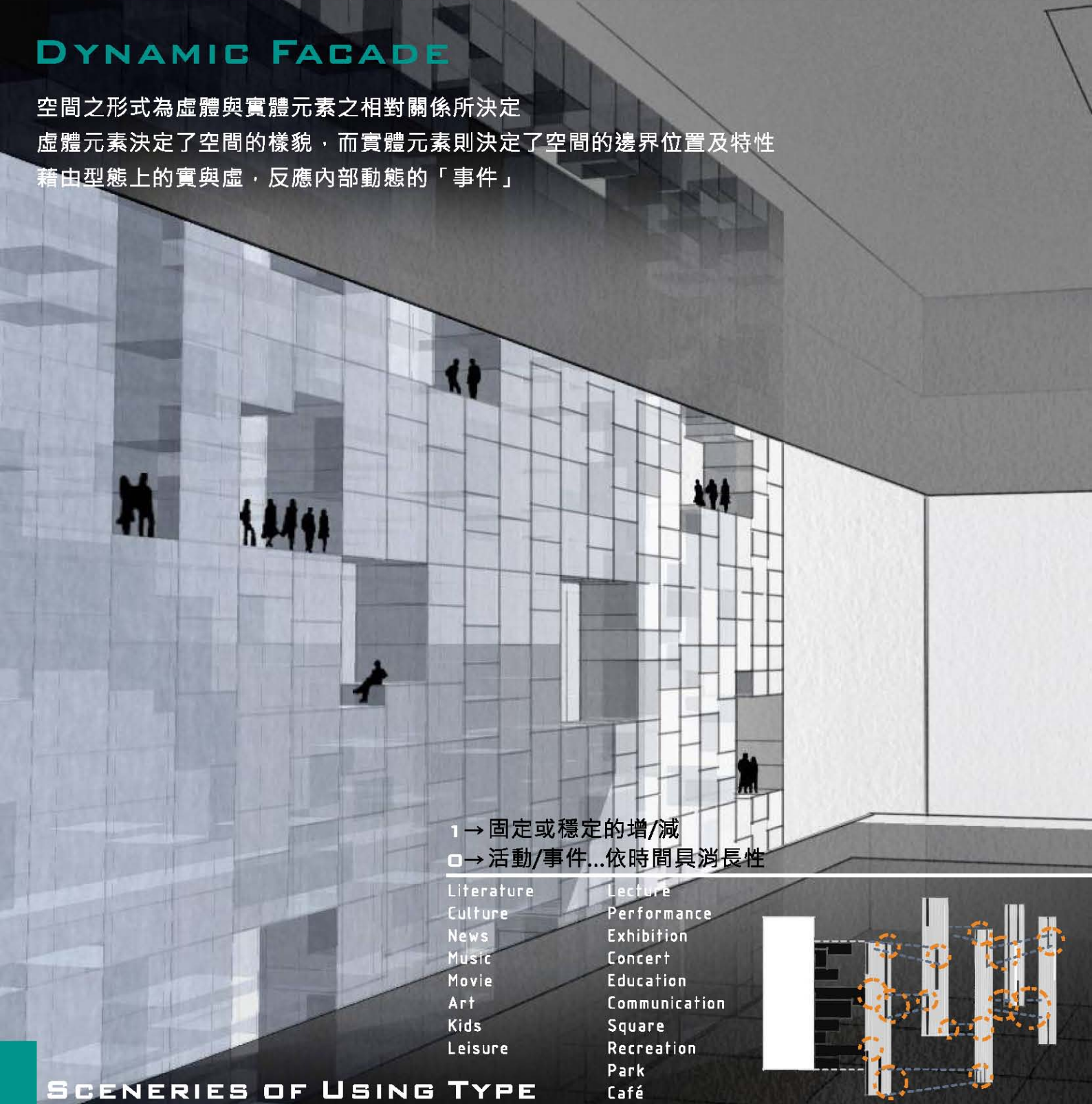

1 → 固定或穩定的增/減
0 → 活動/事件...依時間具消長性

- | | |
|------------|---------------|
| Literature | Lecture |
| Culture | Performance |
| News | Exhibition |
| Music | Concert |
| Movie | Education |
| Art | Communication |
| Kids | Square |
| Leisure | Recreation |
| | Park |
| | Café |

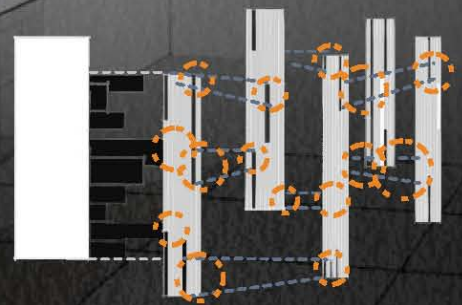

SCENERIES OF USING TYPE

01-TRANSITIONAL SHELVES LIBRARY
PERMUTATION & COMBINATION OF 0&1



USER

NETWORKING

- LAB / STUDIO
- MUSIC / MOVIE
- ART
- HISTORY / CULTURE
- LEISURE / RECREATION
- KIDS
- MEDIA WALL
- MOVABLE LIBRARY/EVENTS



ENTRANCE LOBBY

EXHIBITION (LANDSCAPE)

HOPPING / BOOKSTORE

VISIBLE USERS

- THE THEME OF THE BOOK SHELVES / WALLS
- JOURNALS
- AUDIO-VISUAL CENTER
- SEARCH RESOURCES
- KIDS

PUBLIC ZONE

- MUSEUM
- MIXING CHAMBER
- READING ROOM
- PEOPLE SHELVES

STAFF / ADMINISTRATION / LIBRARIANS

- OFFICE
- SERVICES ADVISORY
- STORAGE SPACE
- REST ROOM
- CENTRAL CONTROL AREA

ACCESSORY / EQUIPMENT

- PARKING
- BOOK STORAGE
- TOILET
- GENERATOR / MECH. ROOM

PATH / ELEVATOR / STAIRS

1

PROGRAMMING OF 0&1

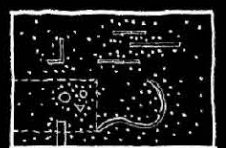
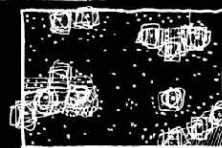
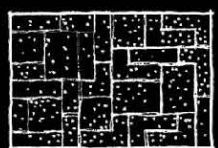
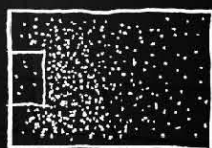
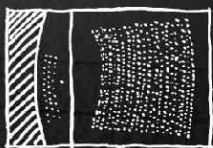

A. Exhibition

B. Plaza / Stage

C. Amusement Park

D. Garden / Cafe

E. Theater



CLASSIFICATION

透過分類的動作，定義不同屬性的「書架」，表示書架的各棟建築物，則承載著分類後涵容的各種活動與閱讀行為。

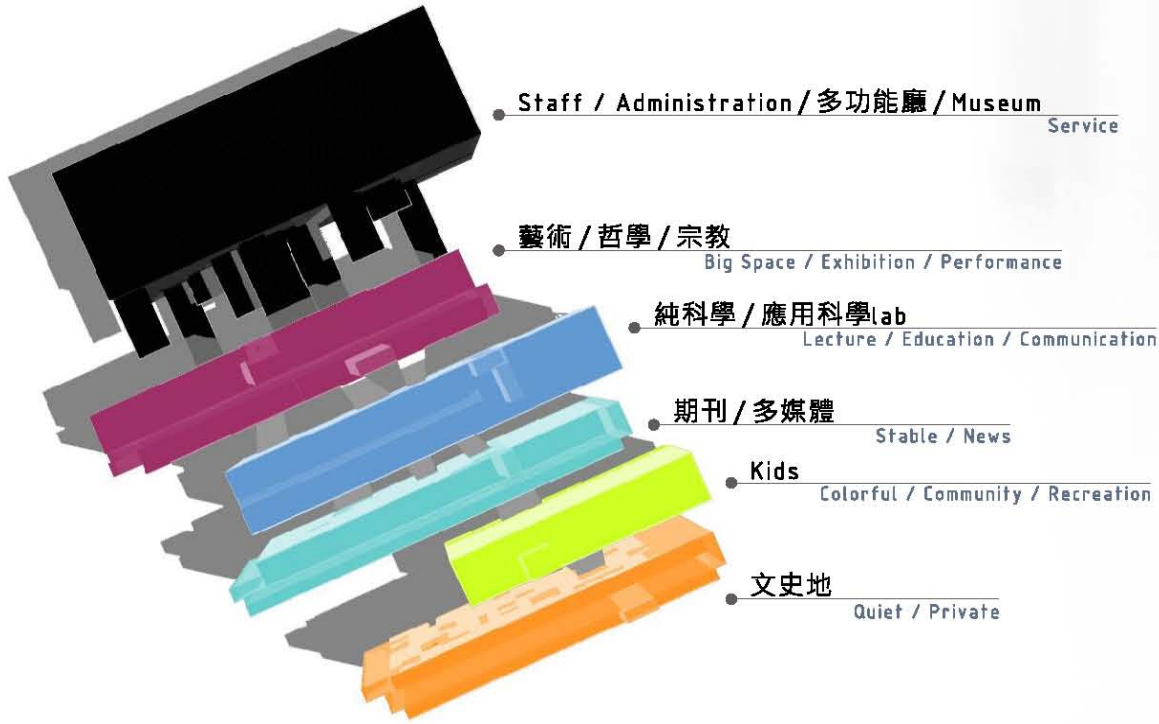

PERMUTATION
UNIT TYPE

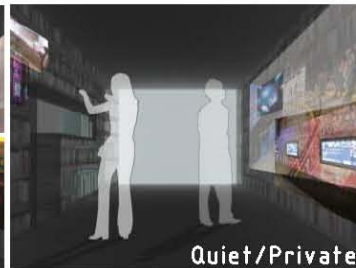

01-TRANSITIONAL SHELVES LIBRARY
PERMUTATION & COMBINATION OF 0&1



RESPONSIVE ENVIRONMENT

人們於圖書館中的活動、閱讀行為，將被反應於立面上；空間的開放性與私密性、活動的密度，立面上層與層間的距離，亦將於外部交疊呈現。

人們到圖書館閱讀，閱讀的人也構成圖書館的風景。

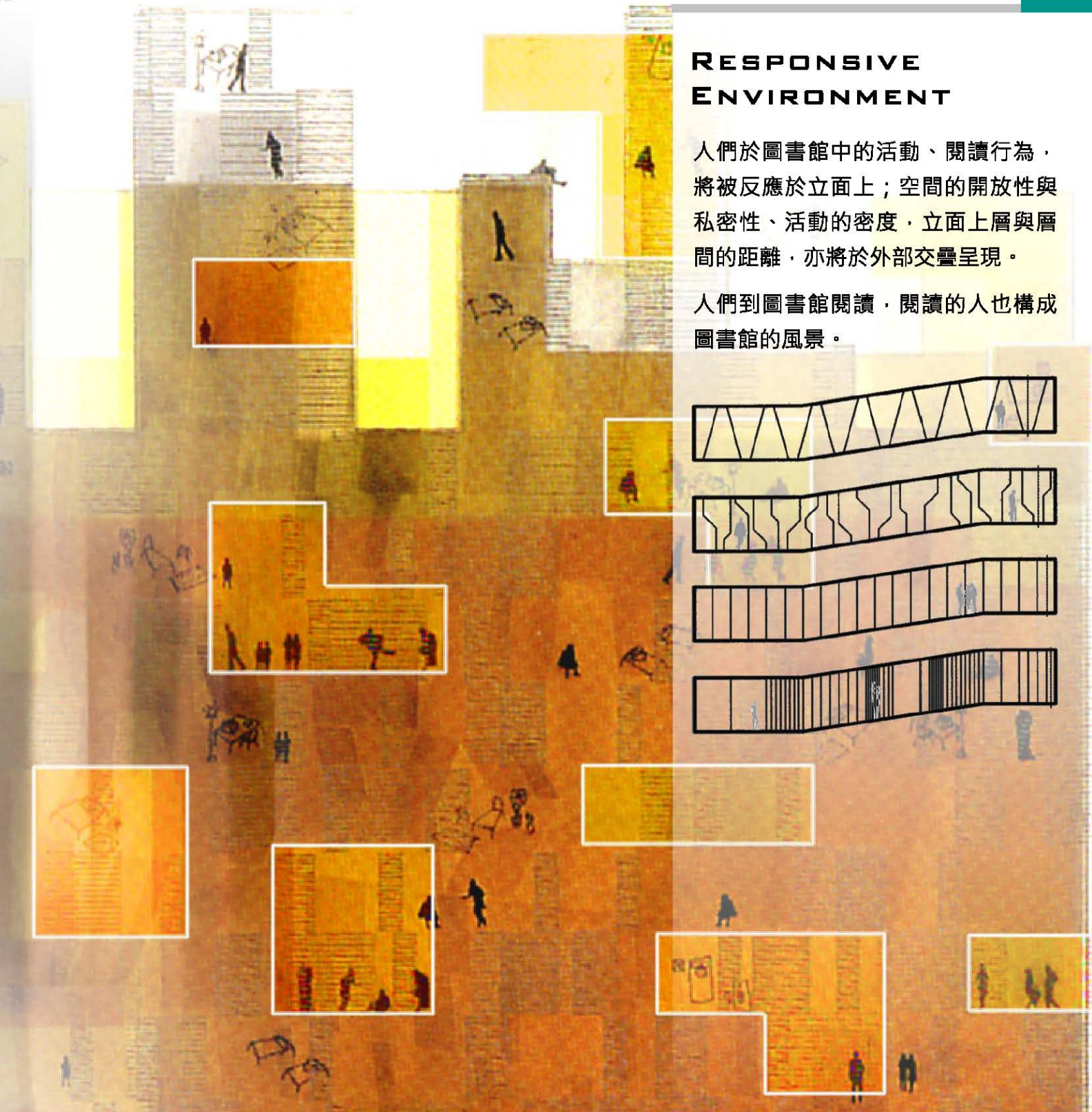



TRANSITIONAL SECTIONS/ELEVATIONS

Spatial permutation and combination of 0&1.

They are not only sections, the use of space patterns directly reflected on the elevations.

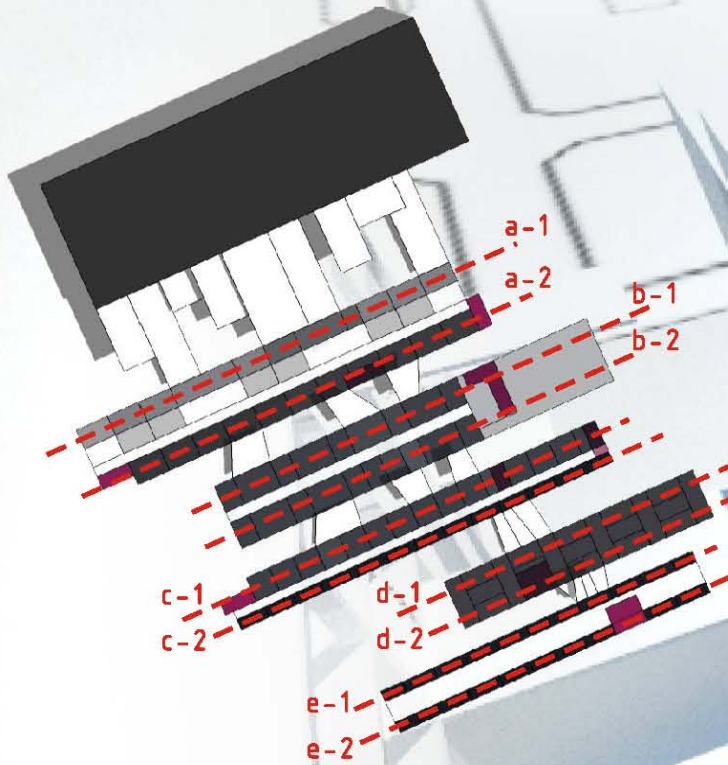

INTERPRETATION FACEDES

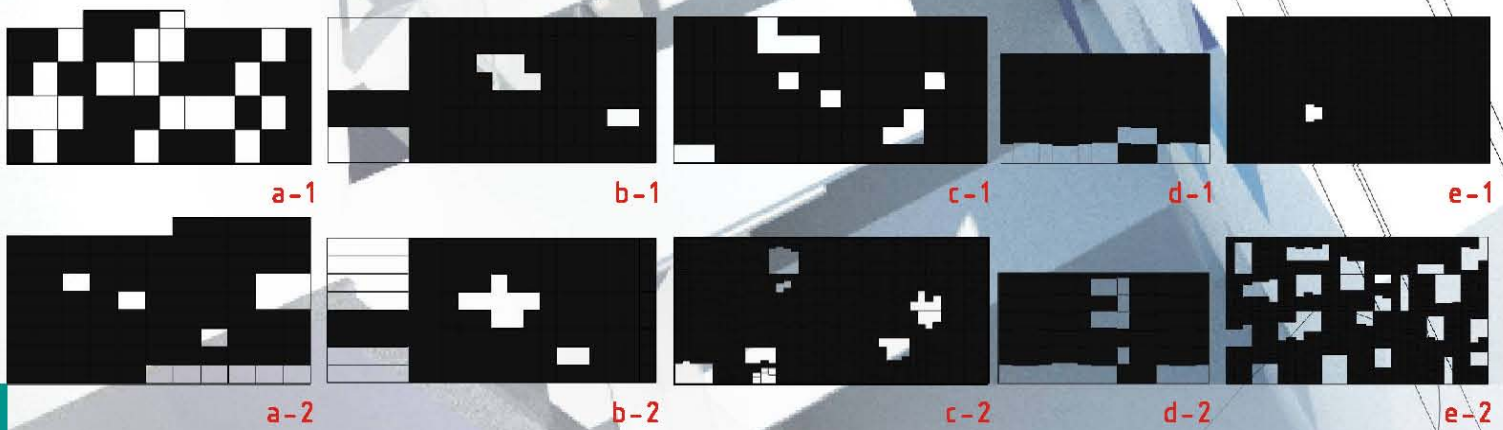

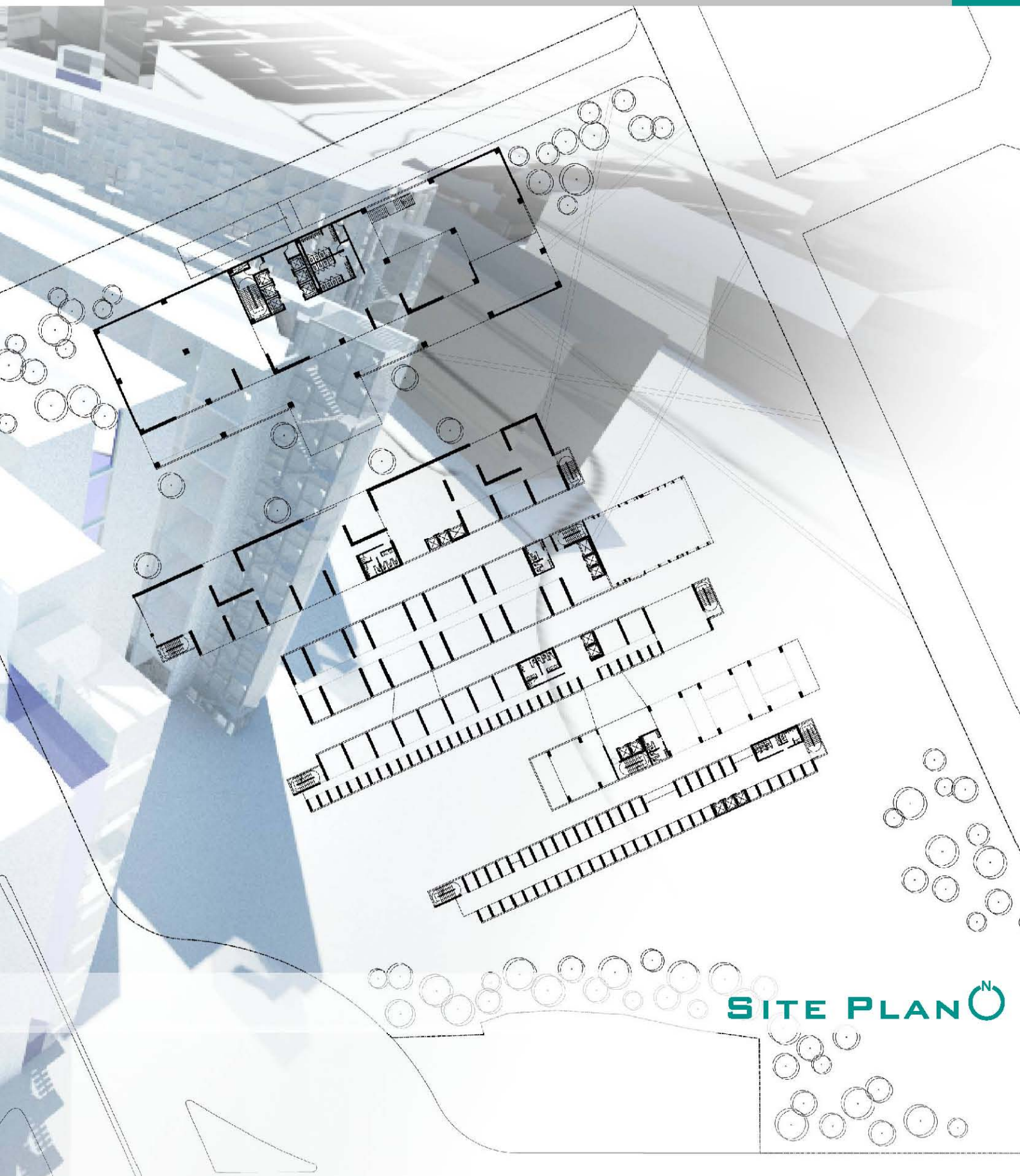

SITE PLAN^N



IN BETWEEN THE SHELVES



STAFF / ADMINISTRATION /
多功能廳 / MUSEUM

藝術 / 哲學 / 宗教



01-TRANSITIONAL SHELVES LIBRARY
PERMUTATION & COMBINATION OF 0&1



純科學 / 應用科學LAB

期刊 / 多媒體

KIDS

文史地



TRANSITIONAL SHELVES LIBRARY

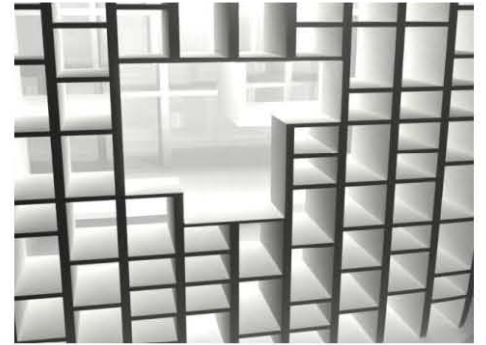

01 - TRANSITIONAL SHELVES LIBRARY
PERMUTATION & COMBINATION OF 0 & 1



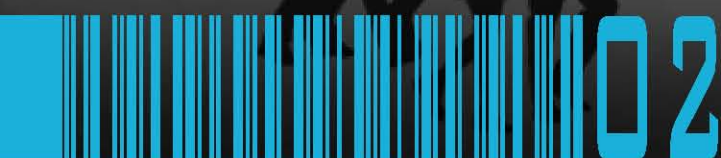

200803-200806

ADVISOR: CHUNG-WEI SU

02-ANCHORING

MUSEUM OF TAI-

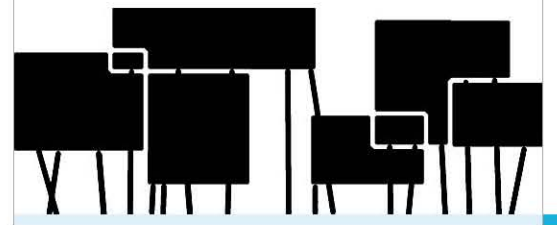

SYMB-DECONSTRUCTION OF HISTORIC SPACE



PEI CITY

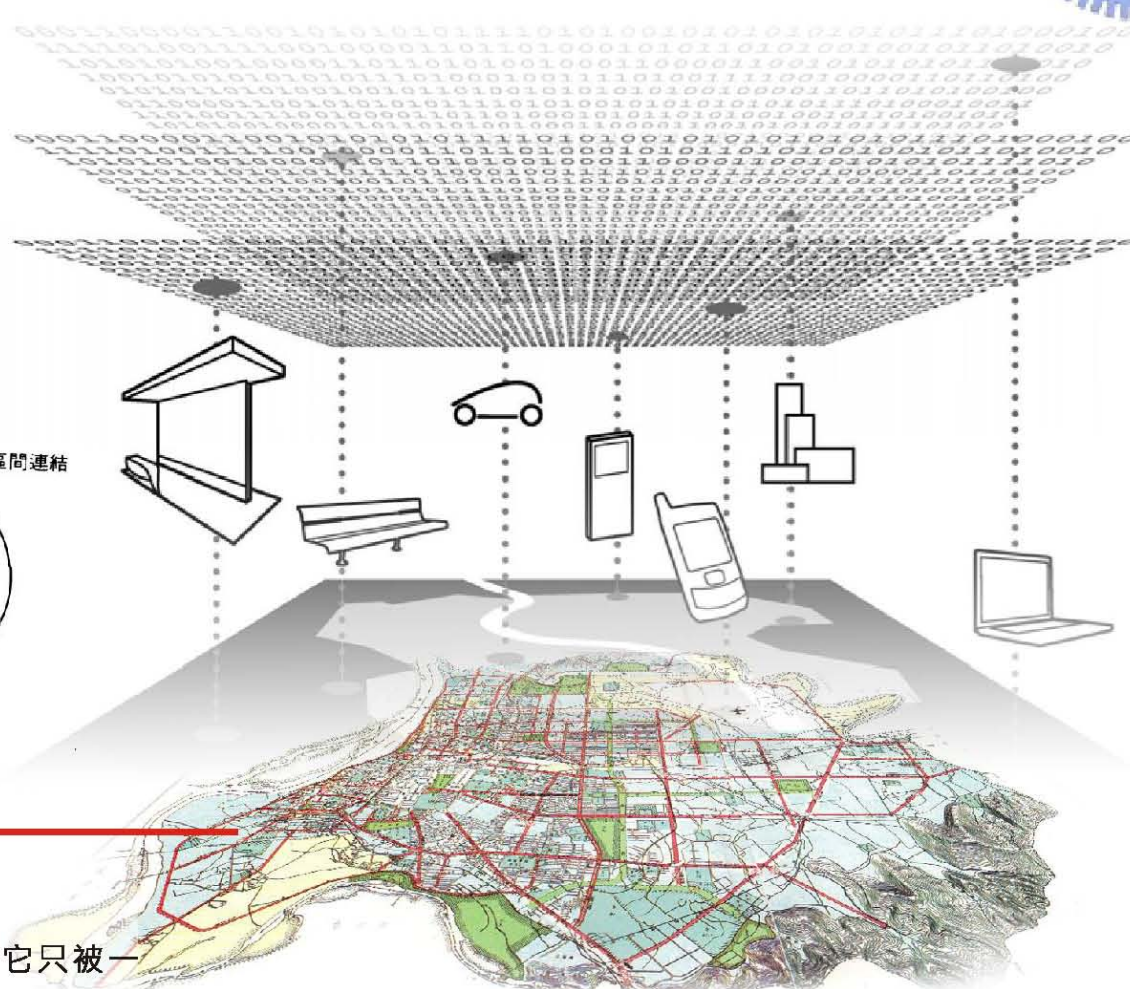

FUTURE

多核心的城市網絡

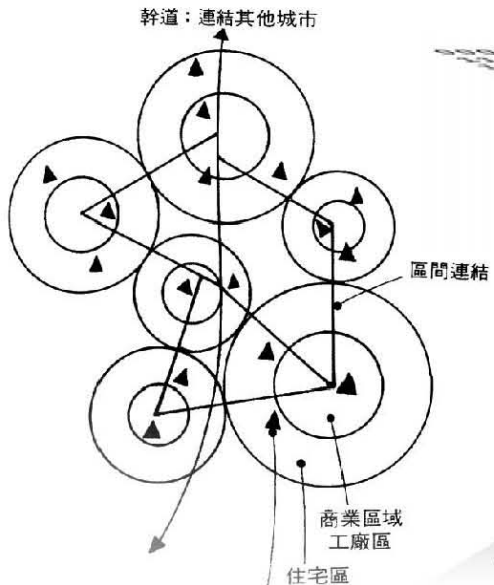

PRESENT

關於時間與空間的錨定...

時間不能再生，在城市裡，它只被一再販賣。標示了時間，標示了空間，我們回到那個感覺交會之點，就構成記憶；時間並不紀錄空間，空間才記錄時間。

記憶有兩軸，一軸是時間，一軸是空間，兩軸標示的任何一點，都代表了一種可能的生活經驗，你實際上行經的點，就構成了你的生活軌跡。

PAST

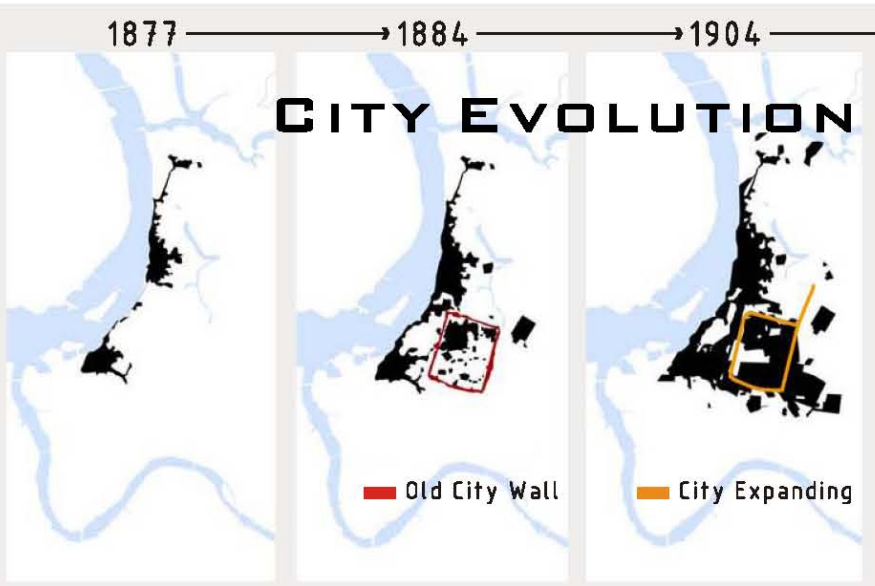



ANCHORING OF HISTORY

現代博物館如今生活在「未來」而非「過去」的歷史之中，博物館實踐的參照點已非傳統與自然界；而是在瞬息萬變的現實中往往要立即的根據判斷從事反思、決策的狀況

--Anthony Giddens

HISTORIC AXIS
-A STORY LINE
Distribution of historic spots

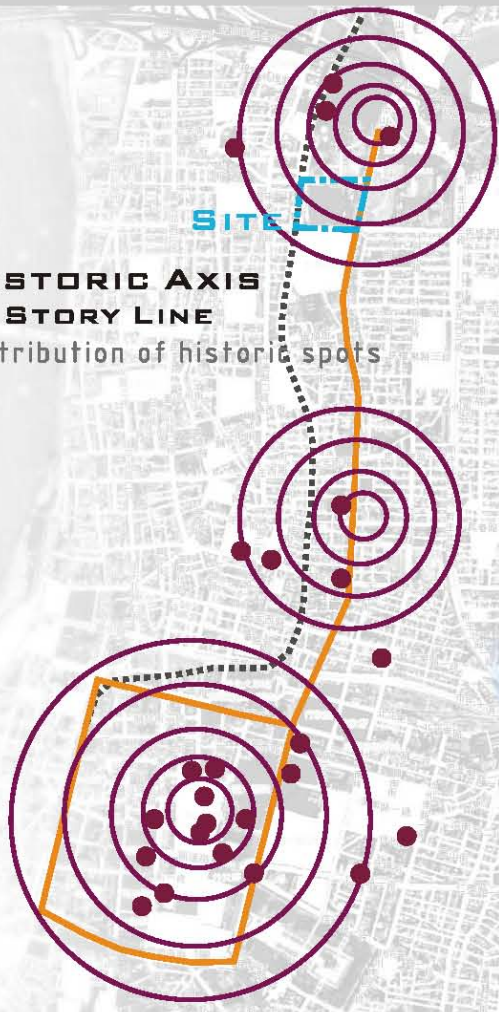

→1945 →2008

CULTURAL AXIS

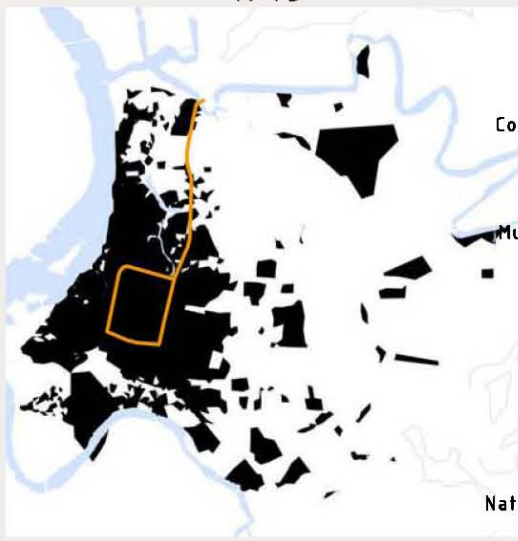

- Palace Museum
- Presidential Residence Park
- Taipei Fine Arts Museum
- Confucius Temple Art Gallery
- Site of Taipei City Museum
- Museum of Contemporary Art
- Museum of Speed
- National Taiwan Museum
- Museum of History
- National Theater/Concert Hall
- National Taiwan University



REPRESENT THE CITY

CITY = COMMERCE + CULTURE + EXPERIENCE + PARK



ACTIVITY CONTAINER

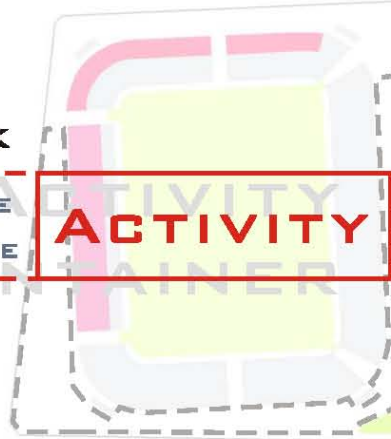

The museum of today is no longer conceived only as an institution for the storage and display of knowledge, it is an urban concept. The museum of Taipei city is no longer only exhibition space to display diverse forms of digital and analog visual information, but also function as space the cater to urban experiences.

The whole block complex can be seen as an analog of the living city in miniature that has similar streets, plazas and gardens. The development of a city always leaves historical traces that hold the collective memory of those who dwell within.

The design is therefore an urban connector as well as a destination point. Base on the distribution of intensity, proceeding to reprogram and deconstruct the original football stadium. In addition to partial reservation, my design is divided into two parts - 1. Lightweight and transparent shell 2. According to the original structure, mode of the stadium to establish the new museum.



ANCHORING

Discontinuous distribution

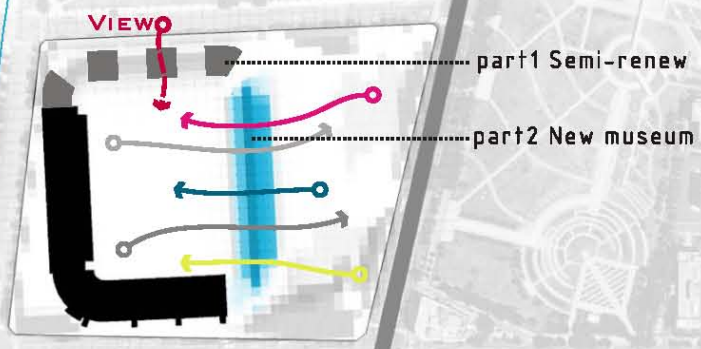

SITE AREA = 60342 M²

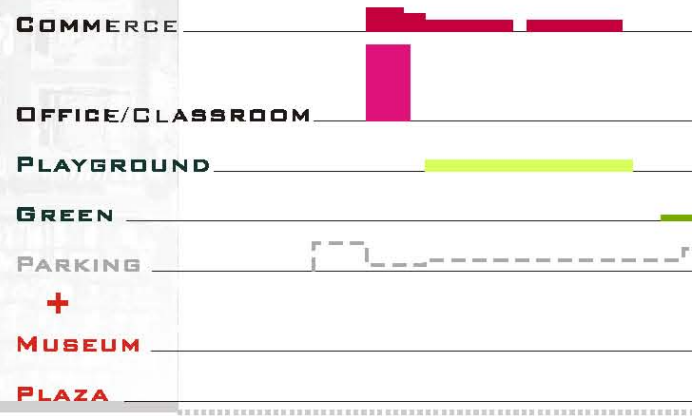

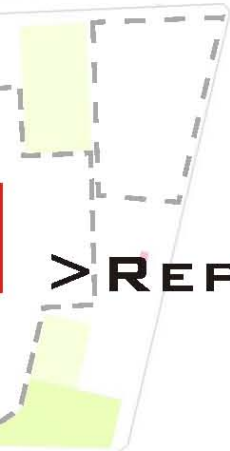

REPROGRAM

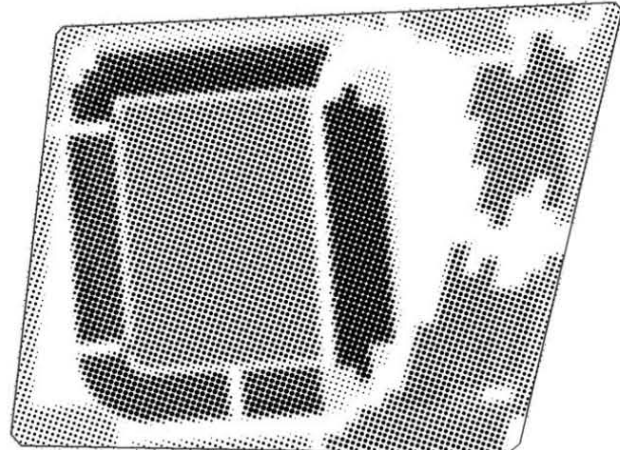
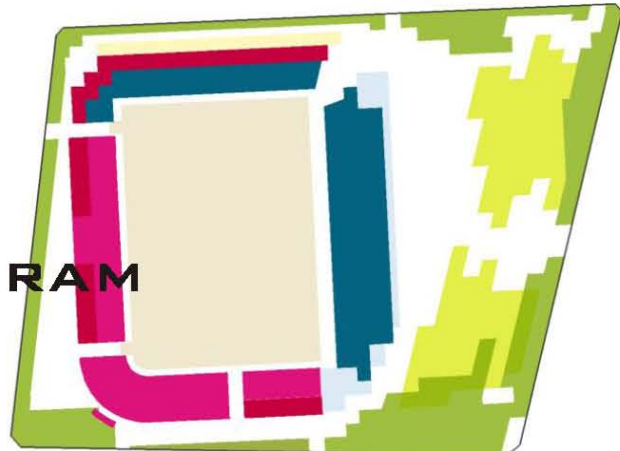

Disruption of intensity



Uninterrupted distribution of intensity

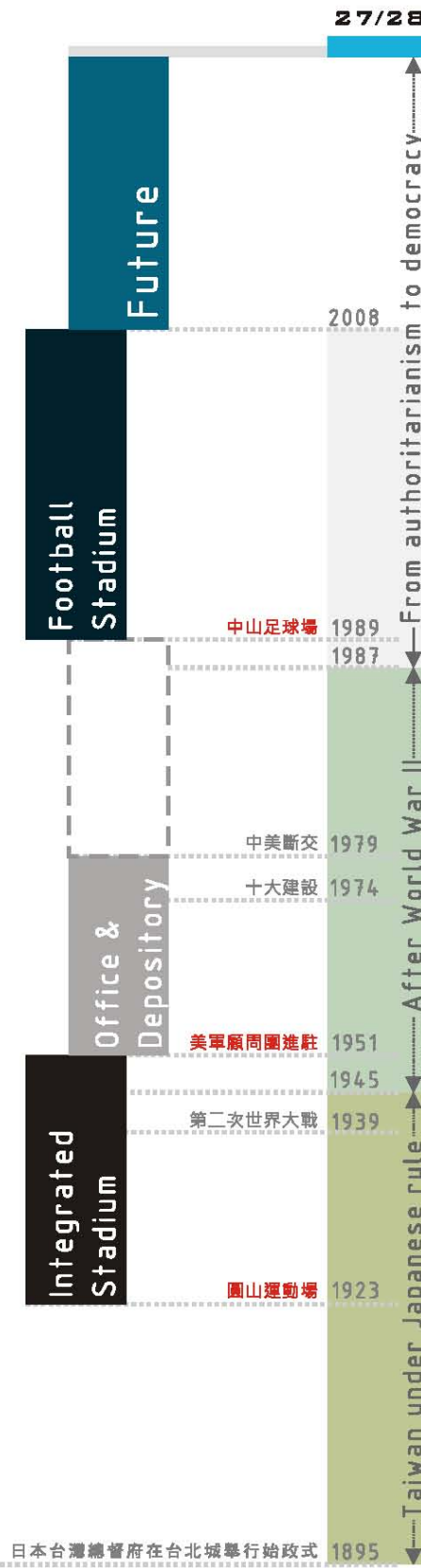



PART 1 - SEMI-RENEW

EVOLUTION OF THE SHELL



Replace the Unused mass

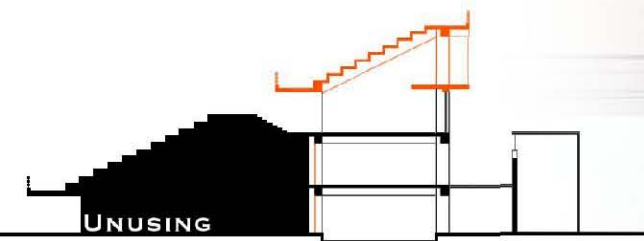

Lighting the Upper mass

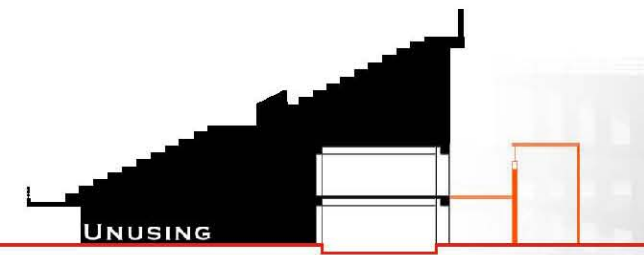

Surface-active to the Street



02-ANCHORING
MUSEUM OF TAIPEI CITY

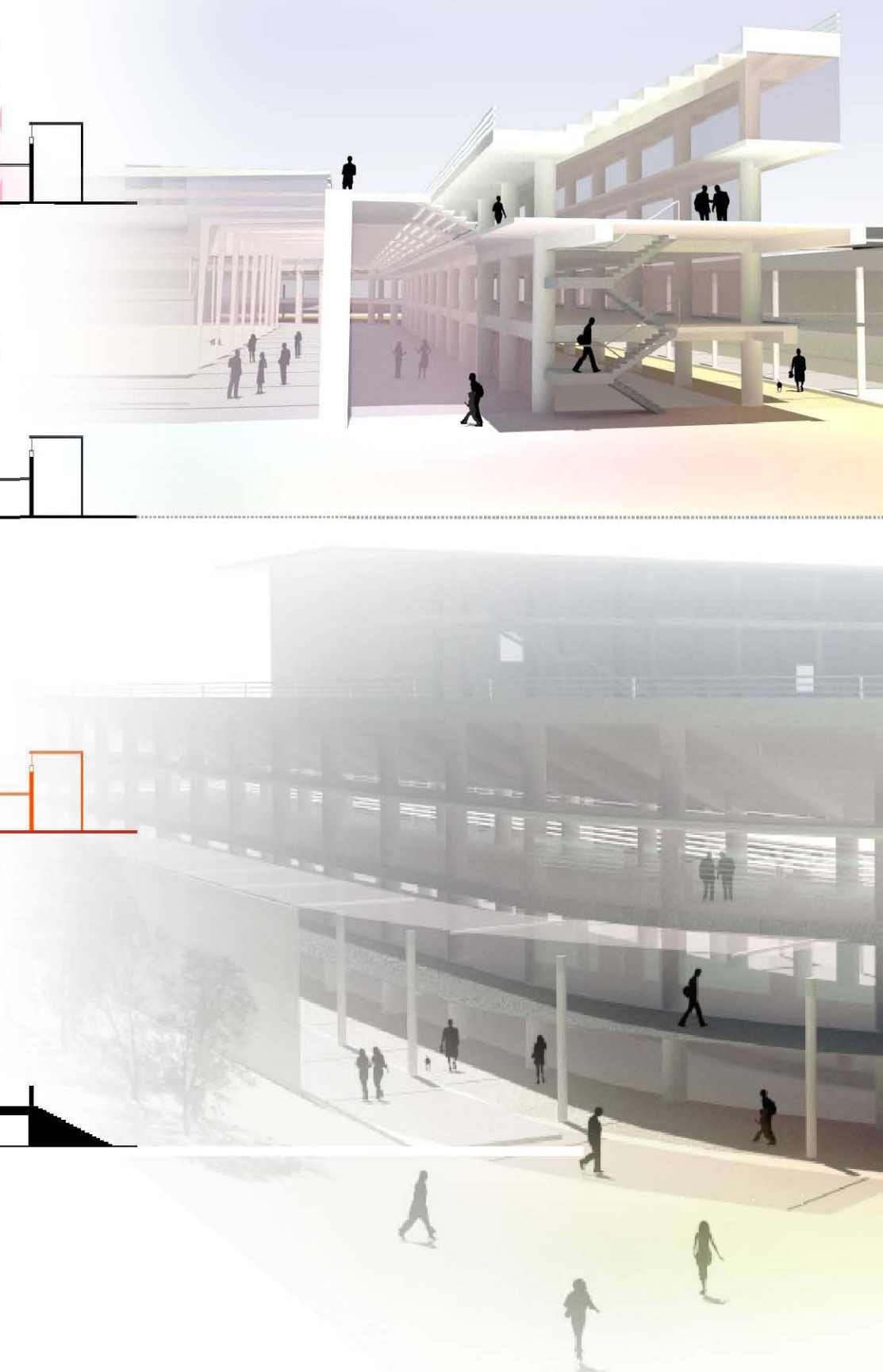

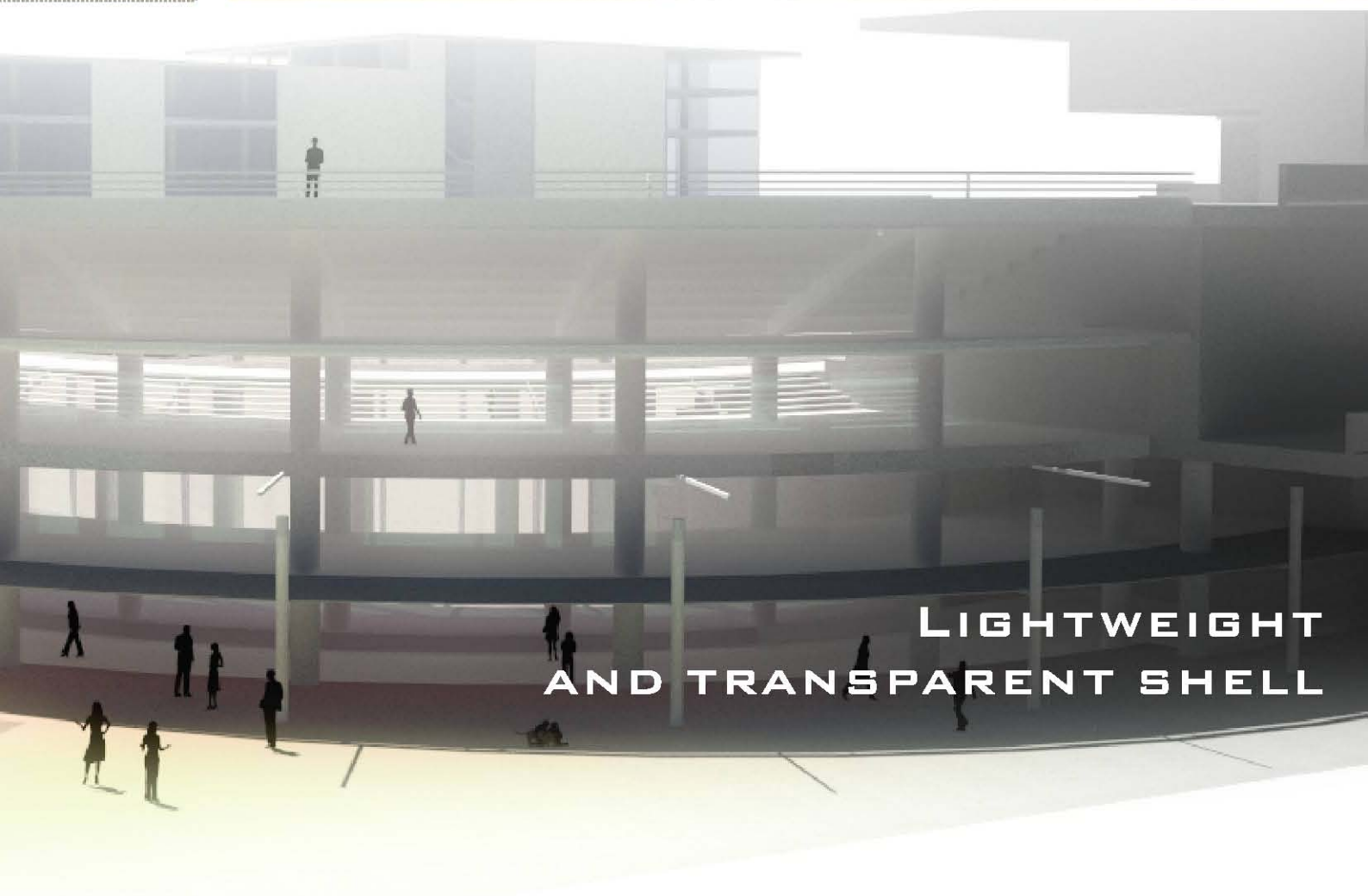
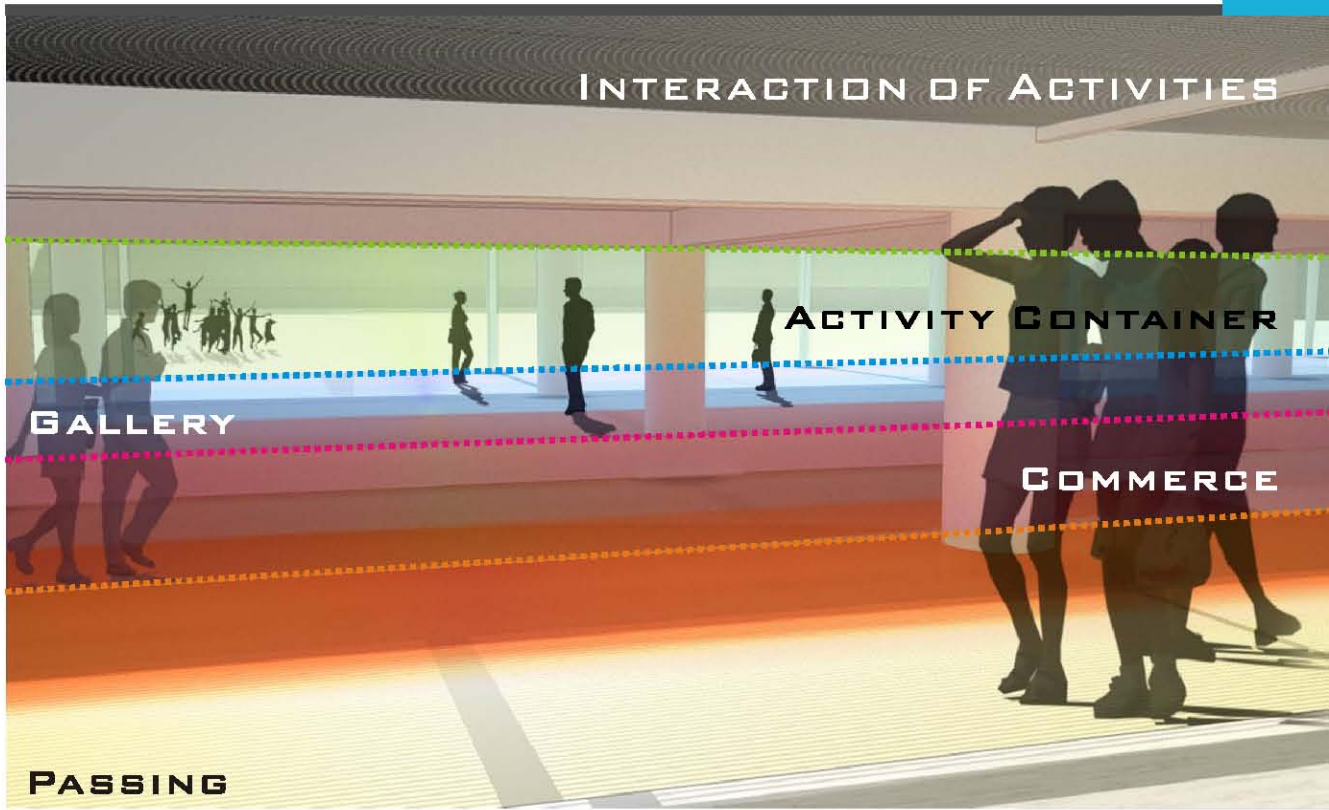



PART 2-MAIN PART OF THE MUSEUM PROGRAMMING RECOMBINATION



MODULE SETTING

Base on the original structure, mode of the stadium, establish the pattern respond to the reservation.

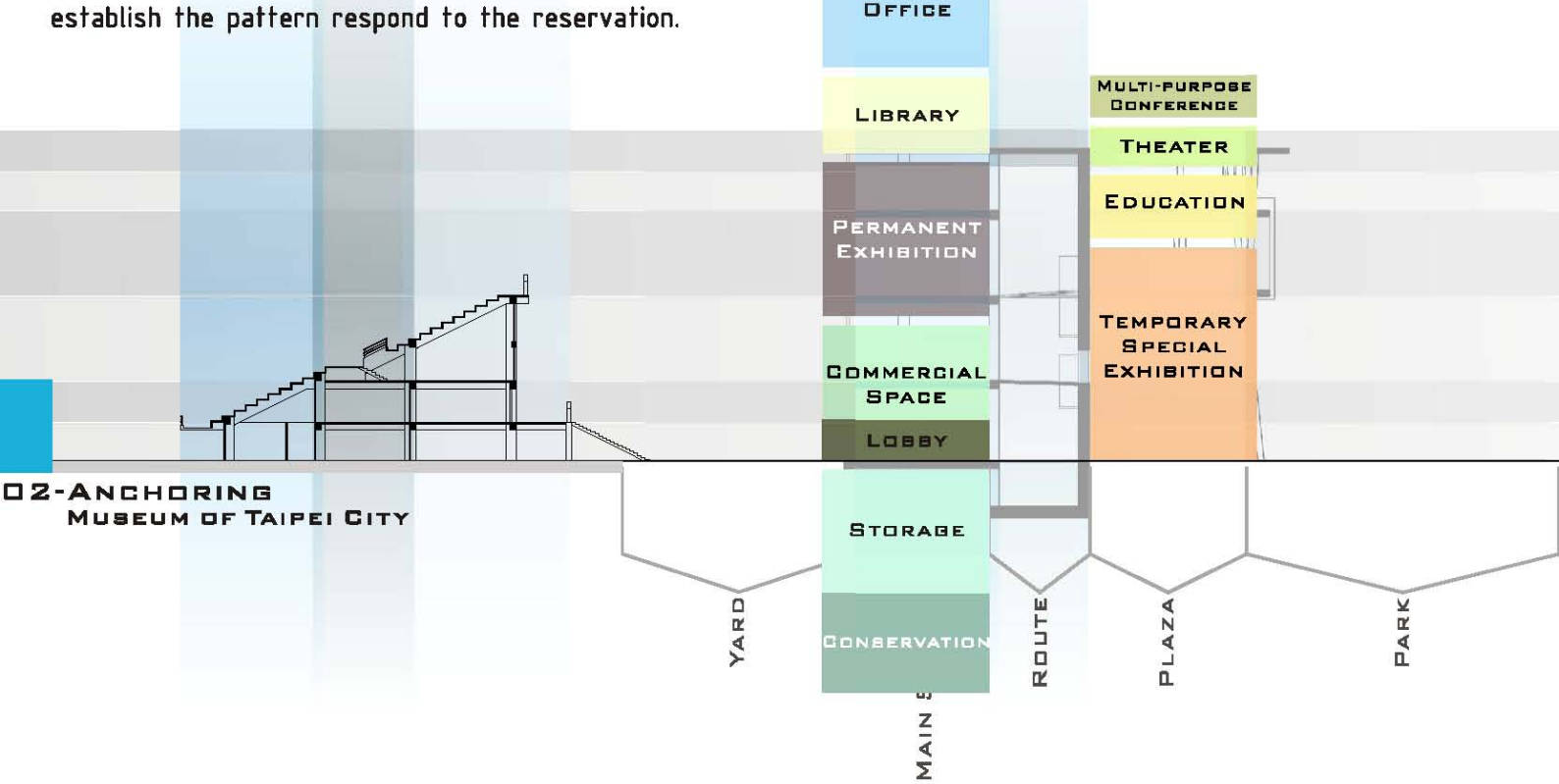



OFFICE LIBRARY COMMERCE

SERVICE PERMANENT EXHIBITION

ENTRANCE/PUBLIC SPACE

STORAGE CONSERVATION

PUBLIC

NON-PUBLIC

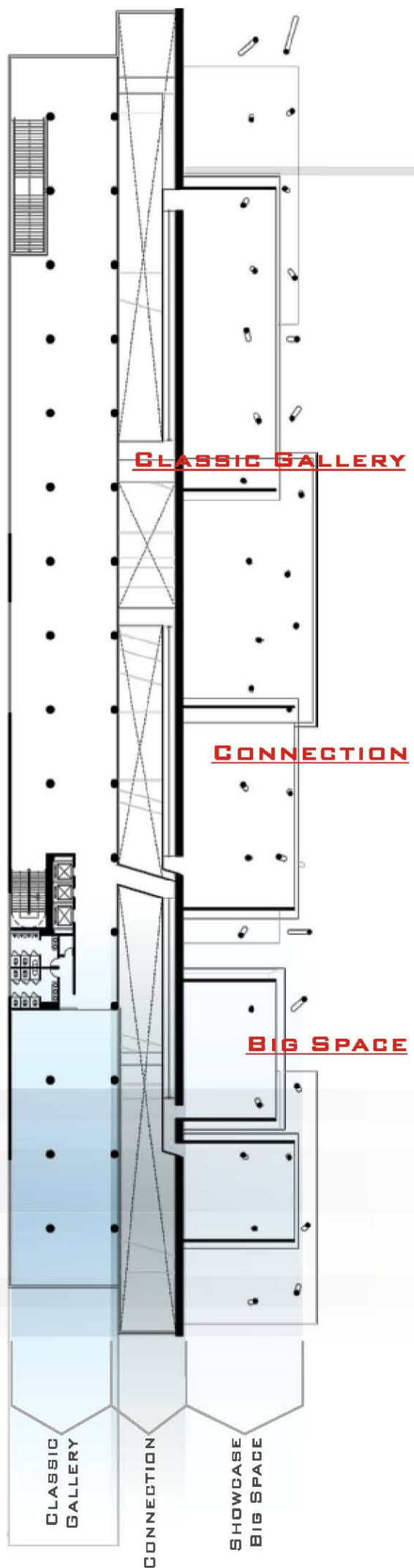



CONCEPTUAL PROFILE FROM SURROUNDING TREES



Skyline of the grove along Zong Shang North Road.



According to the grove, outline the contours of the museum.

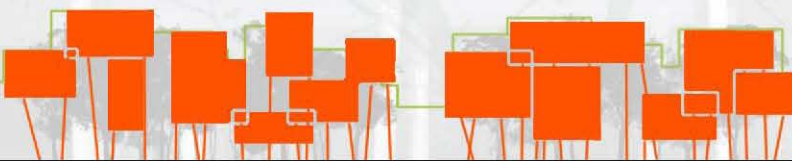

Get balance between surrounding trees and new masses.

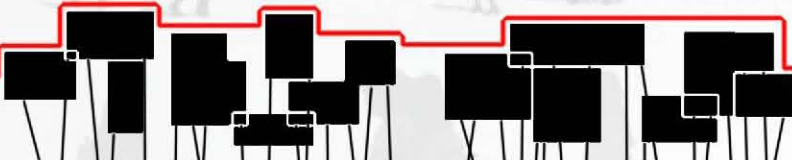

Form a new skyline.

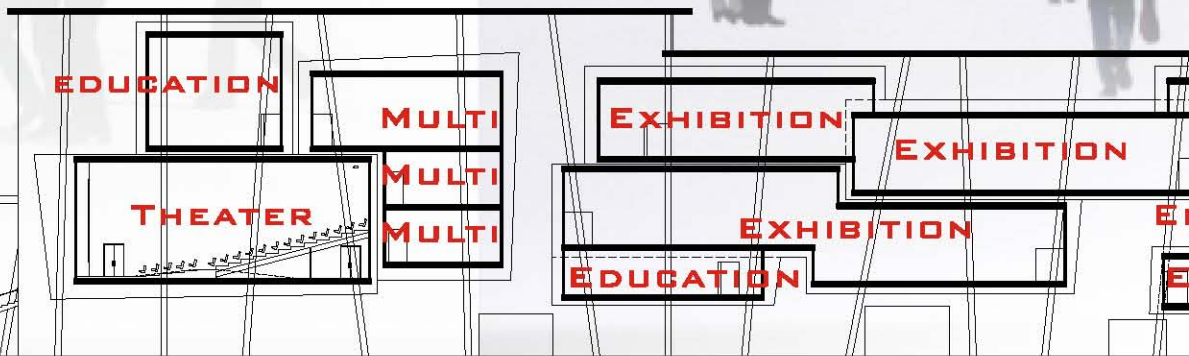
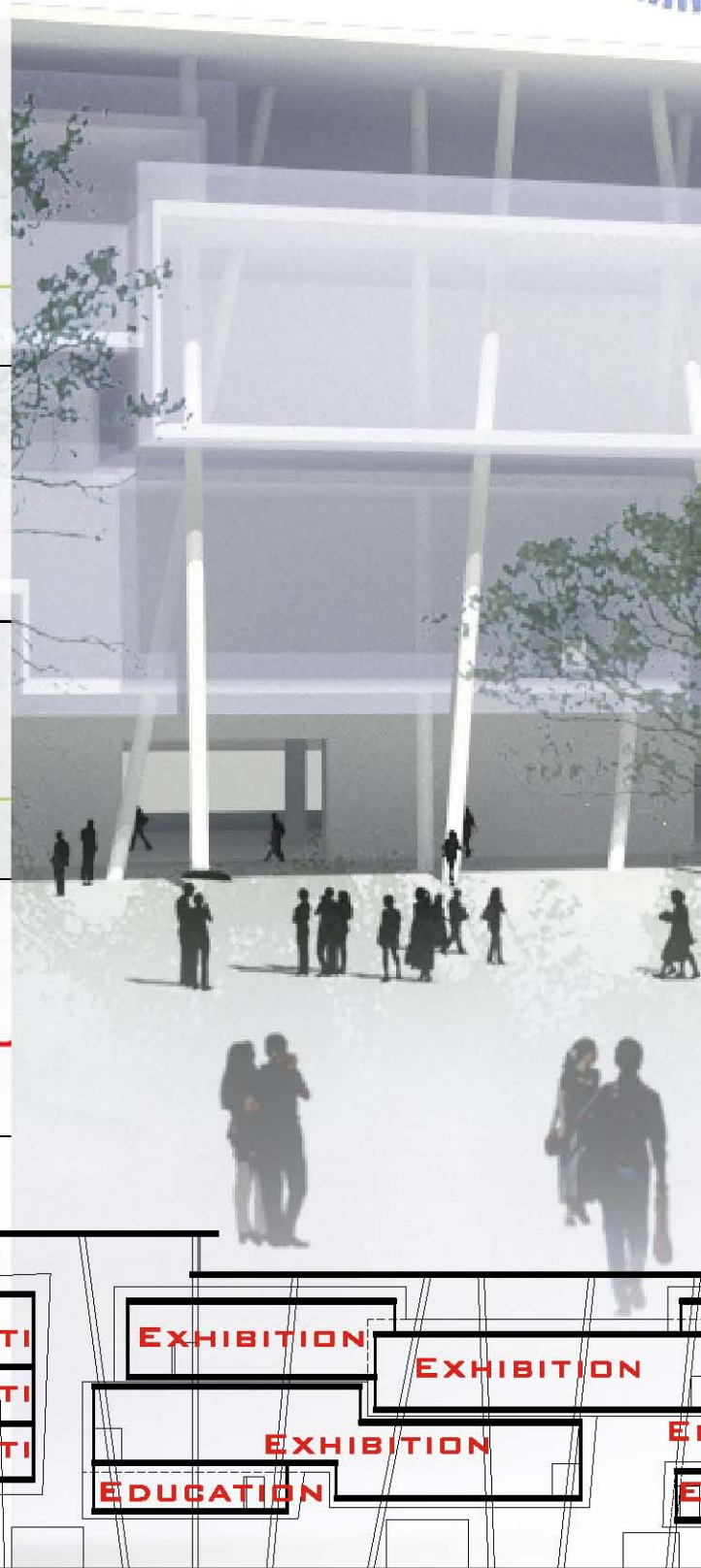

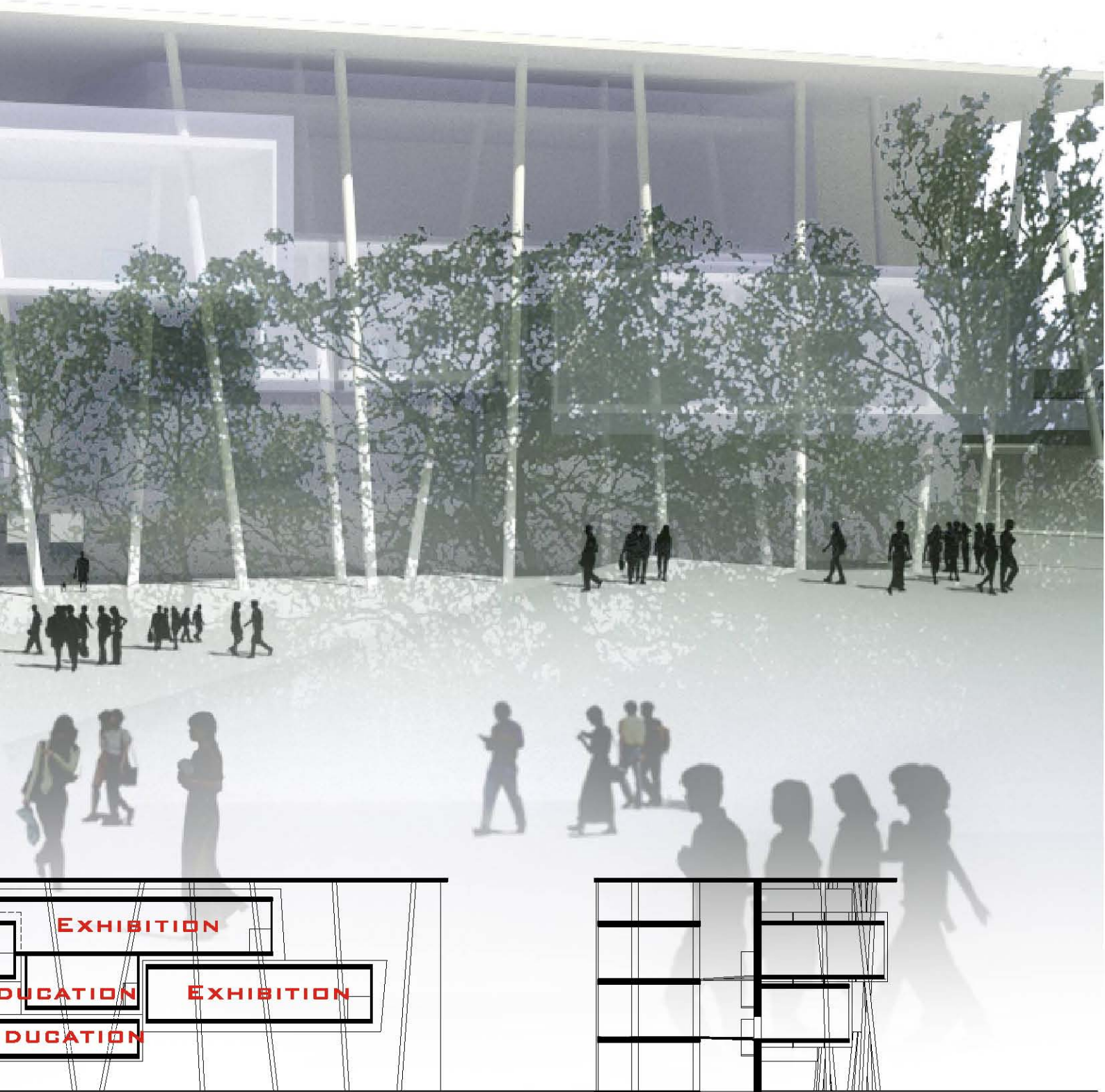

SHOWCASE/BIG SPACE



View1



View2



View3



View4

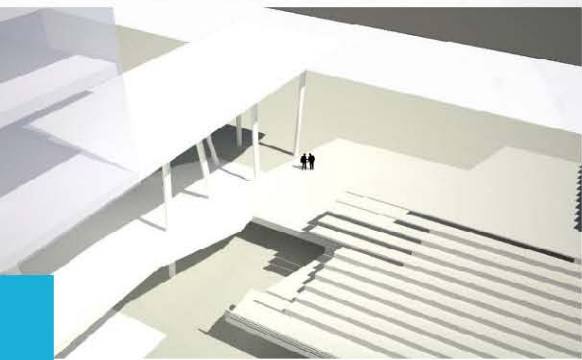

View5

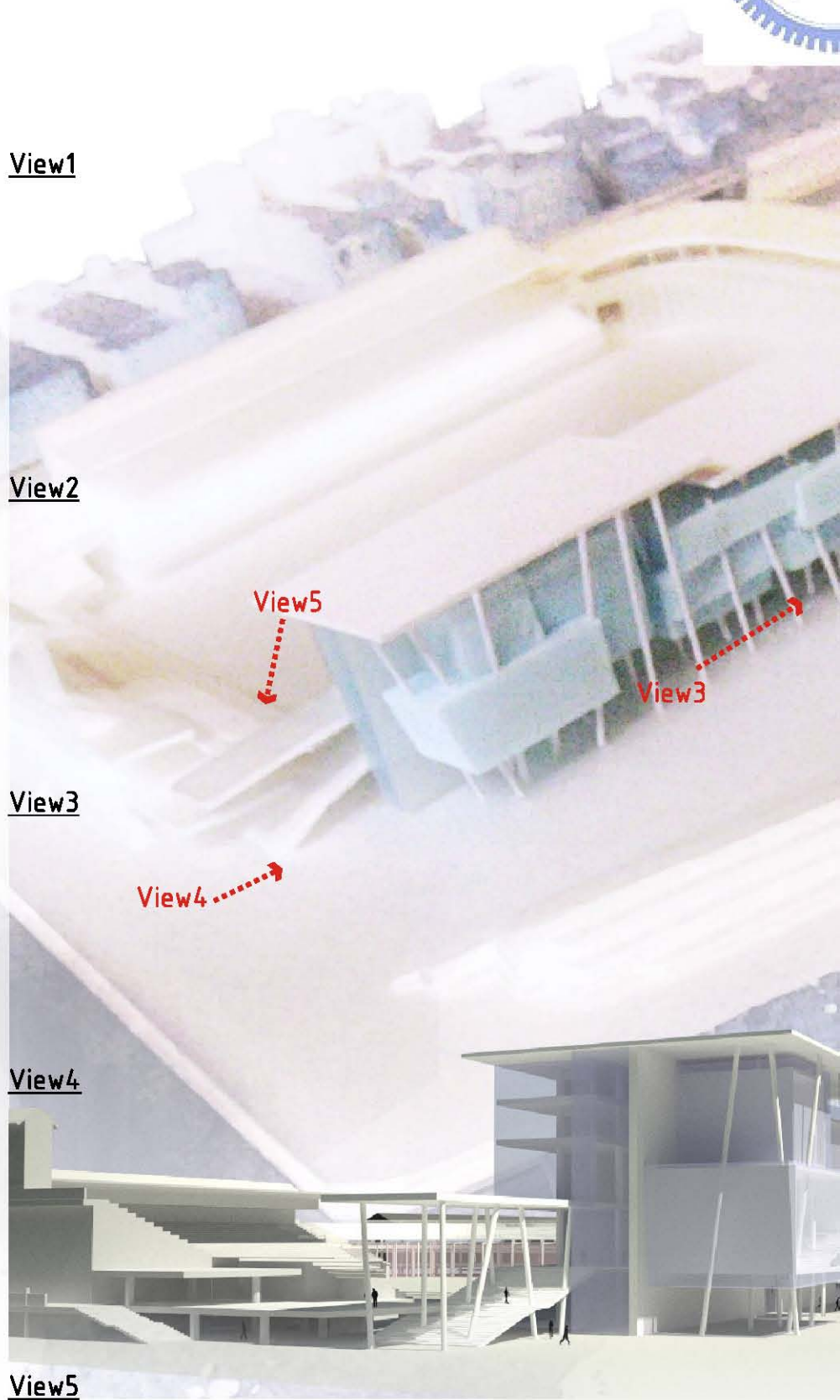

**02-ANCHORING
MUSEUM OF TAIPEI CITY**



DECONSTRUCTION OF ZONG SHANG FOOTBALL STADIUM

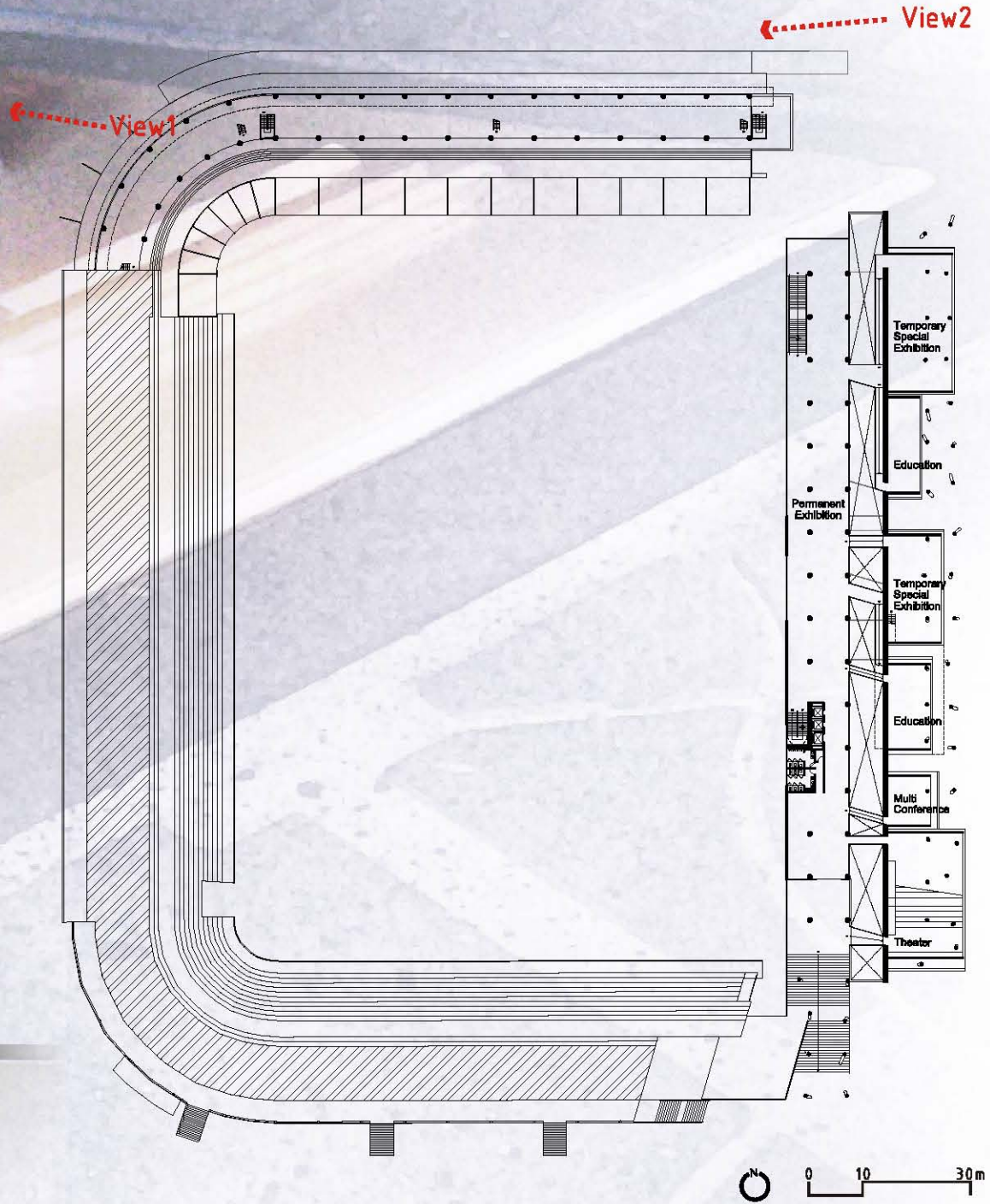



ROAMING IN THE MUSEUM OF TAIPEI CITY



02-ANCHORING
MUSEUM OF TAIPEI CITY

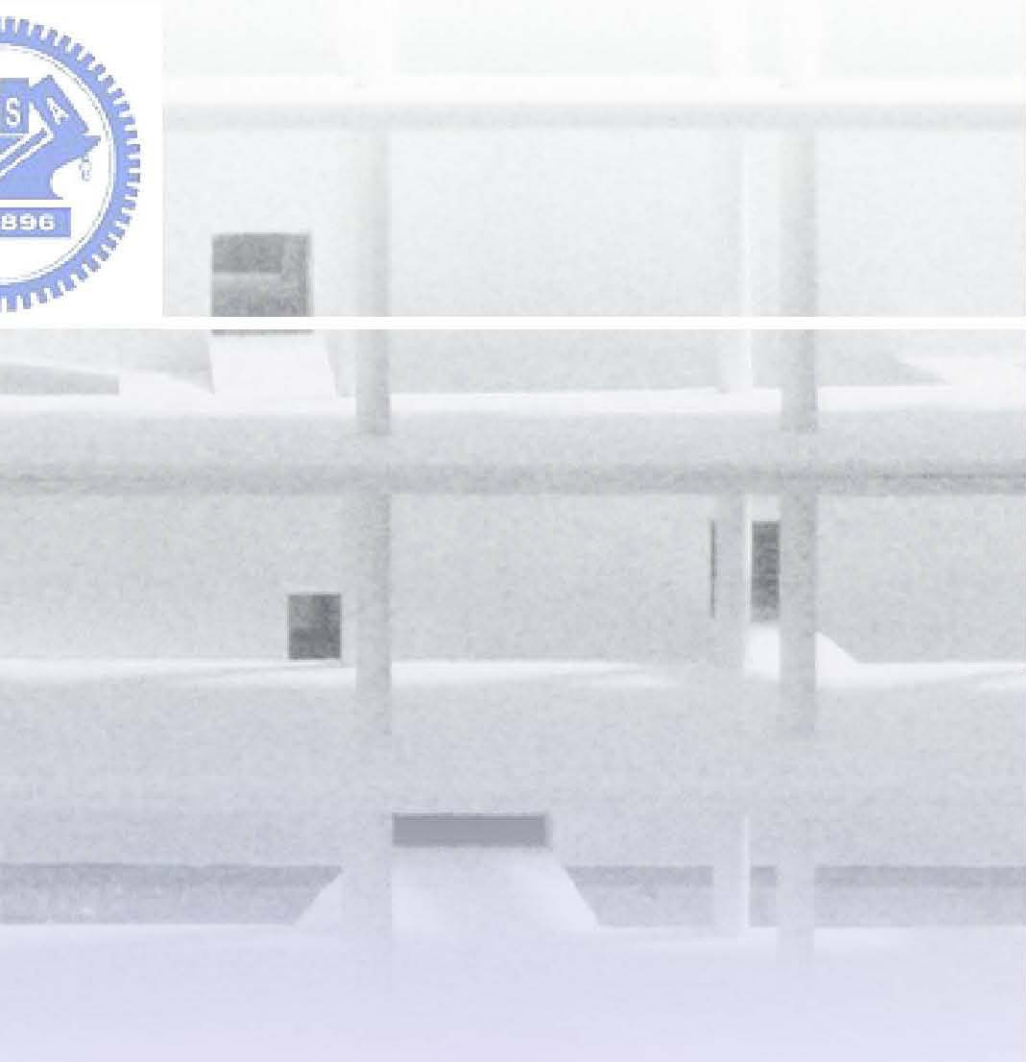



02-SYMBOL

03 - URBAN SUBCON

200809-200901

ADVISOR: WEN-CHIEH CHIU

PRACTICE OF SE

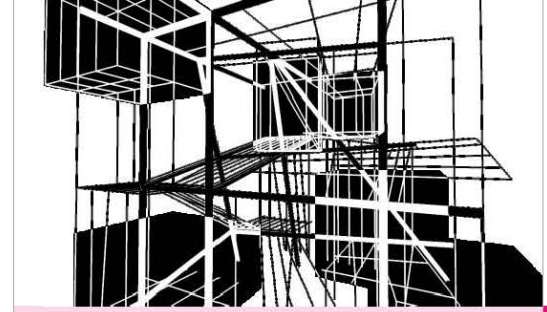

**SYMBOLIZATION OF
TEXTONIC MATERIALS**



01-INTERPRETATION OF URBAN SUBCONSCIOUS

SYMBOLIZATION OF MATERIALS/ESTABLISH CONSTRUCTION SYNTAX

03-PRACTICE OF SELF-DWELLING

**UNCONSCIOUS
SELF-DWELLING**



01-URBAN SUBCONSCIOUS

城市空間的物質特徵及外觀表現，是人在城市生活中最容易識別和記憶的部分，顯示著城市特色和生活水平。然台灣居住的空間對應公共空間環境實體的感覺經驗常不協調，都市裡的違建、擺設、使用形態...反應居民對於居住場所的一種看法，有時是居民對自身生活的書寫，更多時候是對於都市環境的回應與詮釋。

在有限的空間中，人們從不同的行為與活動去呈現一種整體的民族文化性，我們可以說這是台灣的地域性質。

違章建築，記錄著城市複雜發展形成的混亂，片段的失序與混淆，可以視為人們潛意識對空間欲求的物化--一種非永久/臨時性的訊息轉譯。

屋頂加蓋、陽台加蓋、鐵皮屋、窗戶加蓋、鐵窗、雨遮等等，遍跡全台灣.....像寄生蟲一般，附身於寄主，其佔地為王的霸氣和繁衍速度之快；在破壞環境之餘，卻有一種令人興奮的活力。

隨著個人的主體性與時間的差異上，建築空間與都市之間產生交流；隨著需求，人們開始不斷的書寫空間。

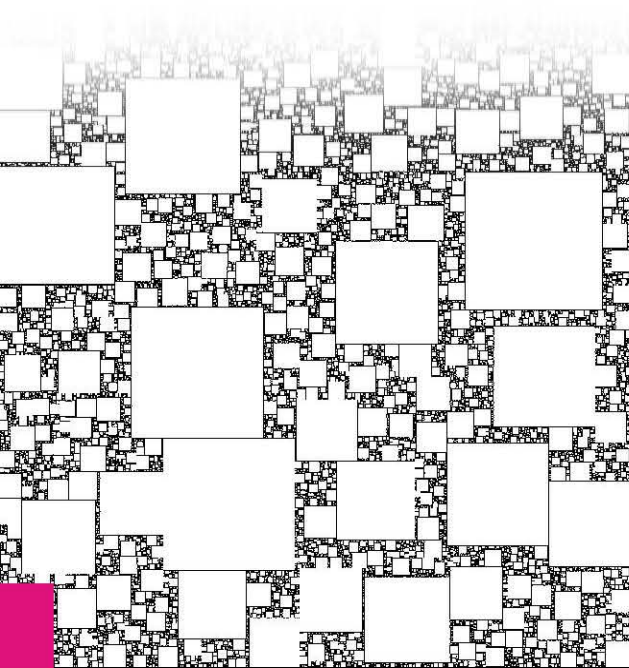

03-URBAN SUBCONSCIOUS PRACTICE OF SELF-DWELLING





材料反映出空間的特性，基於人對空間需求的潛意識，空間的使用傾向於彈性與臨時性
臨時建物的構材多取之於其**易取得/組裝/加工**

使用構材/A

- 「點」構材_螺栓型&螺帽、膨脹螺絲、自攻螺絲、焊接



- 「線」構材_H型鋼、C型鋼、角鐵、方管、圓管、其他型鋼、木條



- 「面」構材_浪板、鋼板、木板



PRIMARY BUILDING OBSERVATION

使用工具/B

-電焊機



-鑽孔機



-磨砂機



-電鑽



-切斷機



-鑽孔機



-剪斷機



-圓盤鉅



-手提式線鉅





02-SYMBOLIZATION OF MATERIALS

STEEL

鋼結構相較於鋼筋混凝土結構而言，因其可在工廠預製，品質較易控制且鋼材具有強度高、韌性大、材質均勻、重量輕，並能藉由不同金屬的含量控制其強度以及施工迅速、擴建或補強容易等優點，為建築中使用越趨頻繁的建材。又其金屬的延性，不同於其他材料，它可以極薄、極細且仍具相當的強度...一邊彷彿極堅硬，架構著主要的結構
另一邊卻又柔韌易塑型，但仍需藉由桿、繫件作支體的構架

WOOD

木材是一種自然、有機、富生命的材質，具備了不同型態、顏色比熱大，保溫性能高、熱膨脹變型小
包覆著人活動的空間，為主要的內覆面材

STEEL & WOOD



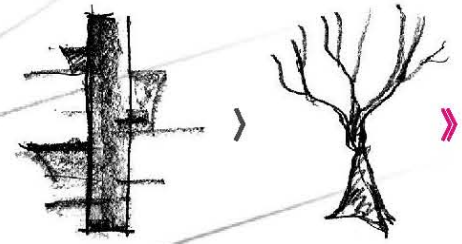

The relationship between the primary and secondary structure

TRANSLATING POINT

2 TYPES OF STEEL CONSTRUCT THE VOID DOMAIN
MAYBE TOUCHING AT A POINT
PARALLELLING WITH EACH OTHER
INTERLACING SOMEWHERE IN THE SPACE
...TRANSLATING AMBIGUOUSLY

CONCEPTUAL MODEL

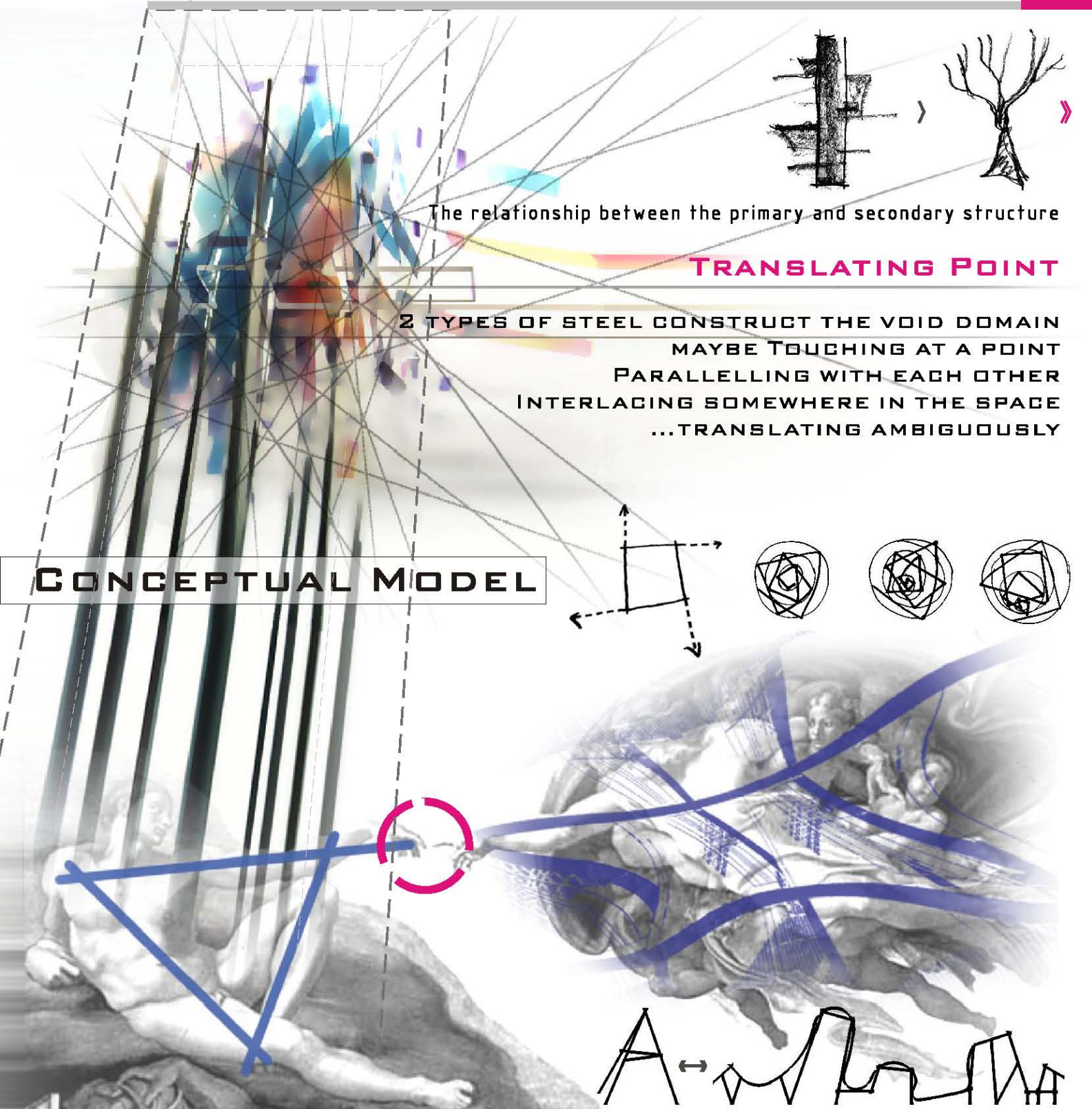
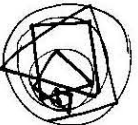
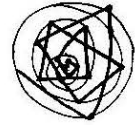
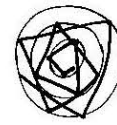
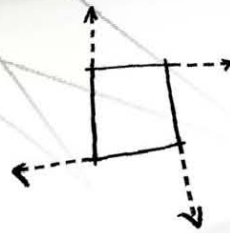



MAIN FRAME
架構空間雛形

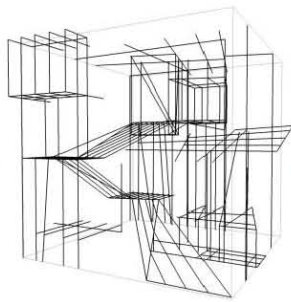

SUB-FRAME
界定活動空間

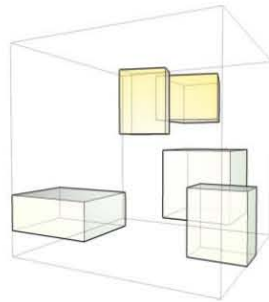

FUNCTION BOXES
填入機能

CONCEPTUAL MODEL

機能盒子不一定要是實空間

虛空間亦屬機能盒子

兩者最後組合而成更大的內外空間關係

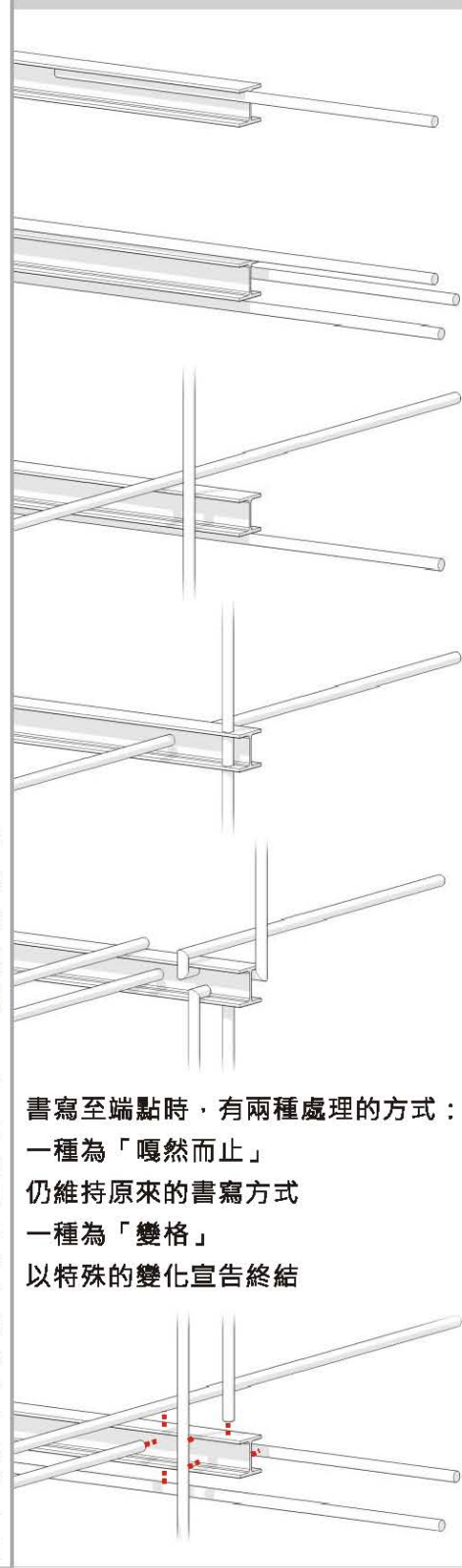

SEVERAL CORES SPREADING IN SPACE

Indicating the Orbits
Making up Distinct Groups
as Centralizing
but also Opposite Dispersing

SPACE GIST

機能盒子即空間的文本，透過構材具象化後建立的「語法」得以被書寫
作為設計練習的自宅-自我對生活的表達、空間的想像即為此處的文本

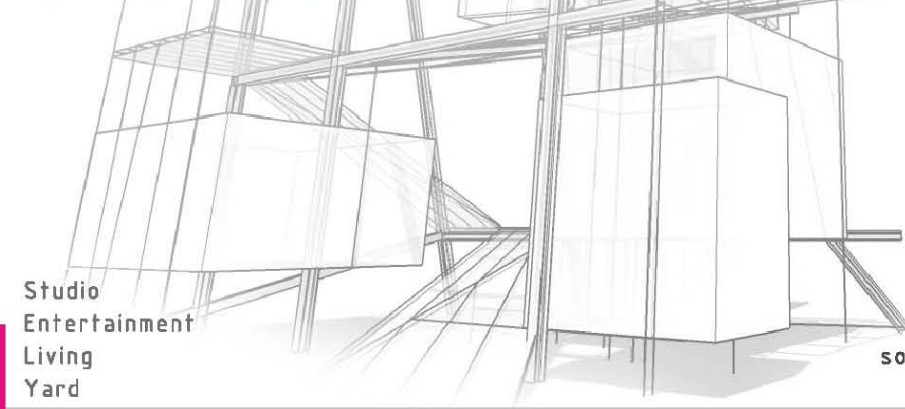

Studio
Entertainment
Living
Yard

read
works
Leisure
play music
sports
eat
cook
home work
bath
toilet
Sleep
TV
social contact
education

書寫至端點時，有兩種處理的方式：
一種為「嘎然而止」
仍維持原來的書寫方式
一種為「變格」
以特殊的變化宣告終結



CONSTRUCTION SYNTAX

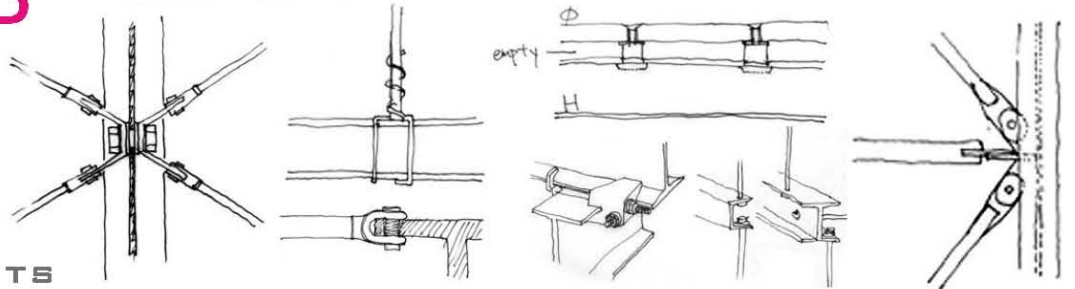
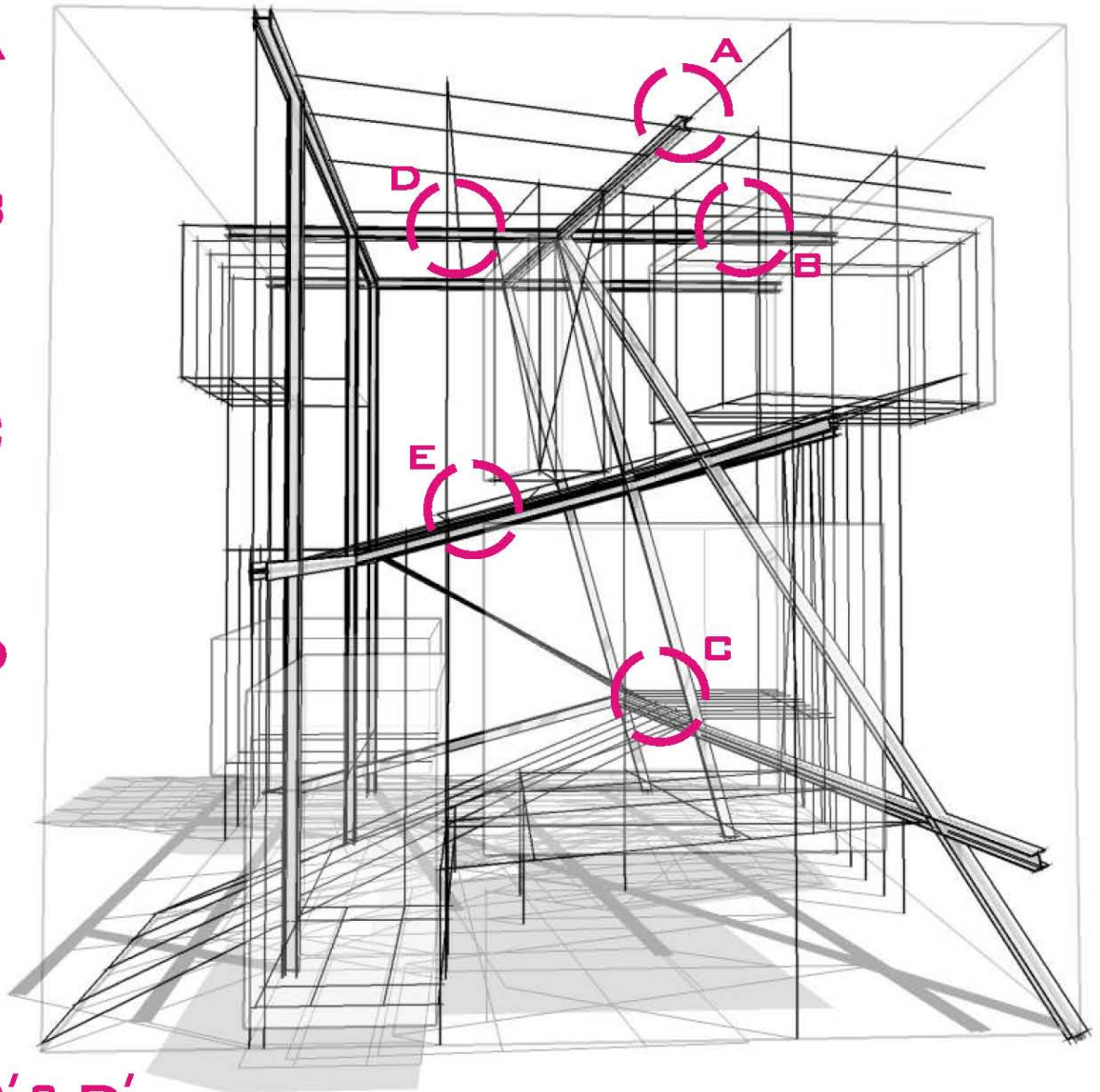
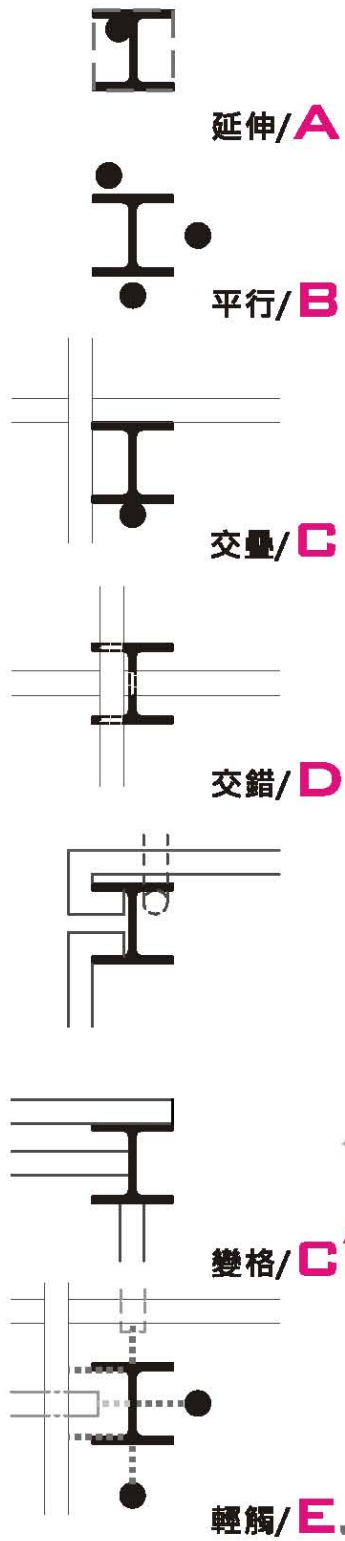

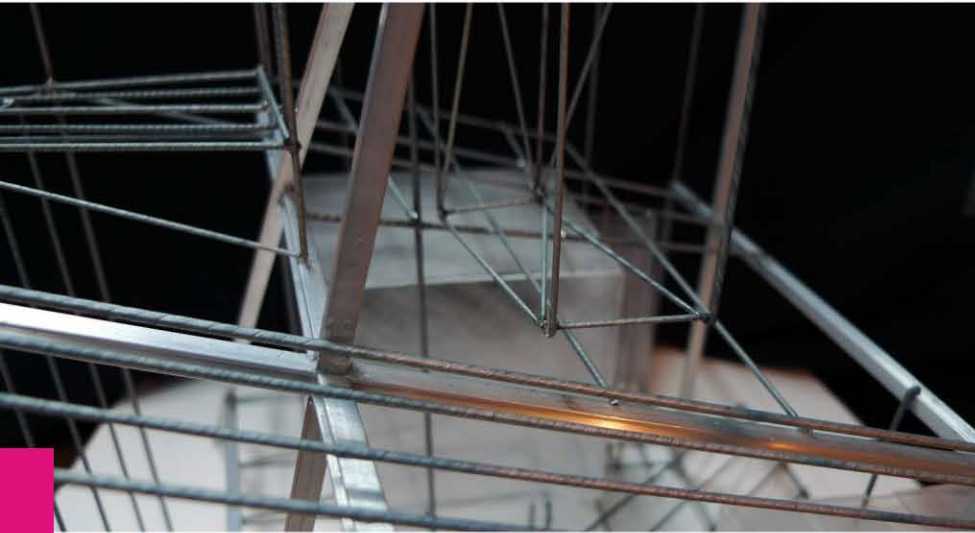
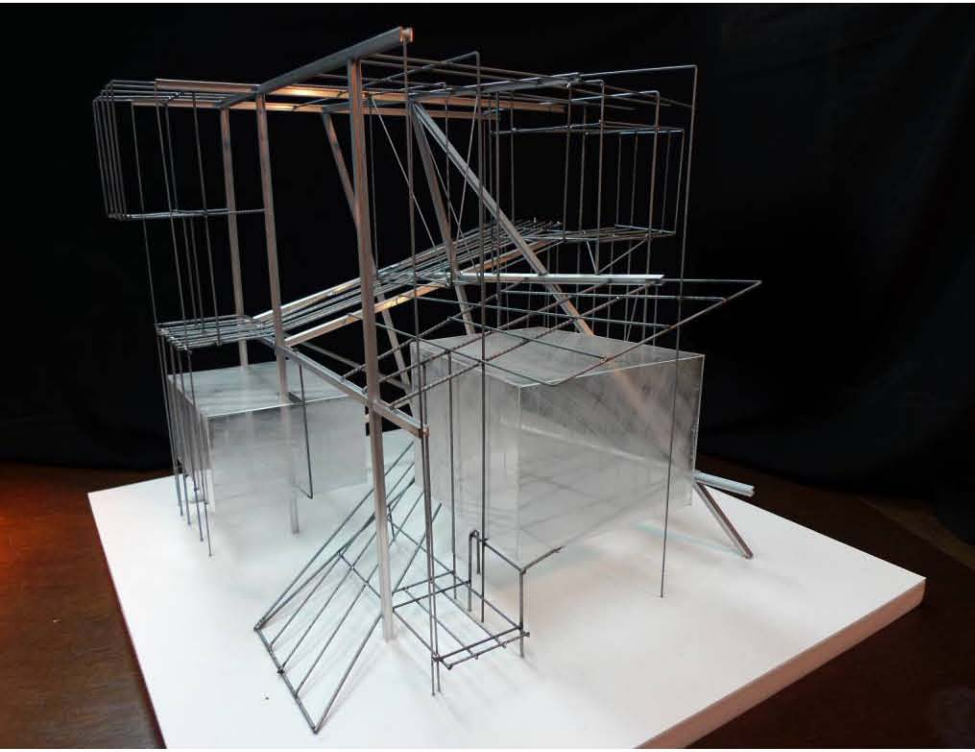

03-URBAN SUBCONSCIOUS PRACTICE OF SELF-DWELLING

構造的系統和空間的形式是兩個不同的體系，如同同語法和語意不可混為一談。

文章必須先有欲表達的意旨，再以書寫的方式完成。只有文字的堆砌而無文意的承載不具書寫的意義
空間形式的掌握，如同文意的佈局與操弄，必須仰賴書寫者在此方面的能力，構造語言並不參予空間

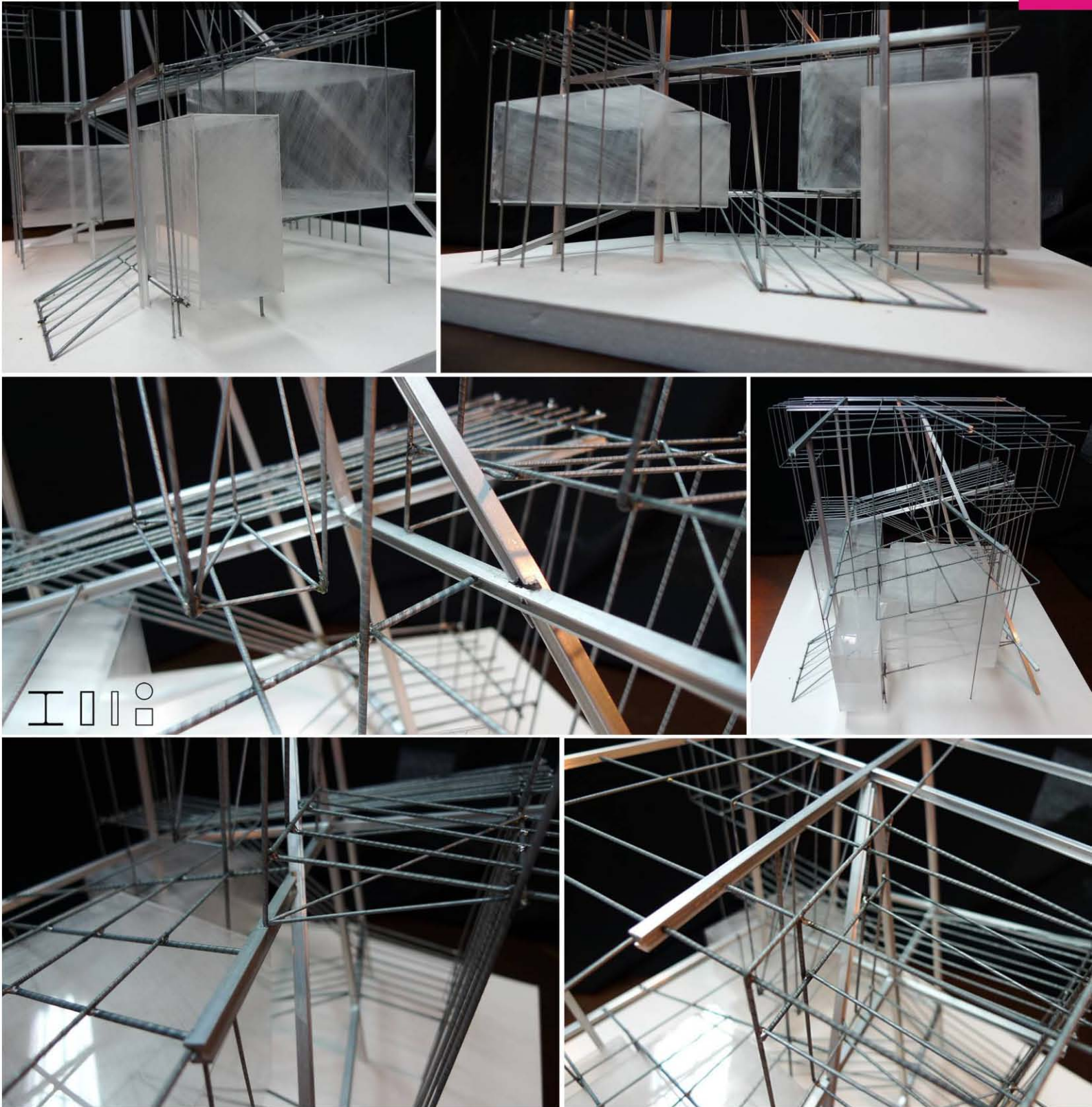

· 只有零碎的意義而無章法結構同樣無法使人明白。

形式的決定；此處僅提出一以特定鋼材為主的構造語言作為書寫的規範。



03-PRACTICE OF SELF-DWELLING FUTURE LIVING IMAGINATION

一個每日通勤的設計師剛獨立，擁有一個家藏納所有的喜好與物；並有自己的工作室--思考工作閱讀與聆聽音樂的場所，並能動手於生活中實踐；另一部分則是我與家人情感交流、梳洗睡覺的地方，也是父母住在離此不遠處的第二窟，也歡迎想稍稍遠離塵囂的朋友來一同分享空間。

因為有家，我的社會關係、我擁有的物品得到了歸屬，在擁擠都市的邊緣固著...想逃卻也離不開的矛盾；欲於快速流動的稀薄空氣中找尋片刻的寧靜，平凡中尋找一些些的不平凡，一點點實踐自己的生活哲學。

每日的上班-下班切換著進入都市-隱於都市；下班之後，開始屬於自己的生活！滿載著記憶(物/空間)與撐托我一路走來的興趣--音樂、繪畫、閱讀、運動...，與家人朋友的互動，在家裡的不同角落得到不一樣的滿足...

家，滿載著個人潛意識對空間需求的實踐；之於鋼材之冷硬卻也柔韌、木材的天然性與恆溫，於特性上某種程度也反應了感官與溫度的矛盾與曖昧。在對於材料的定義與操作下，建立材料之於生活的連結性，一點一點的於空間中構築屬於我的家。

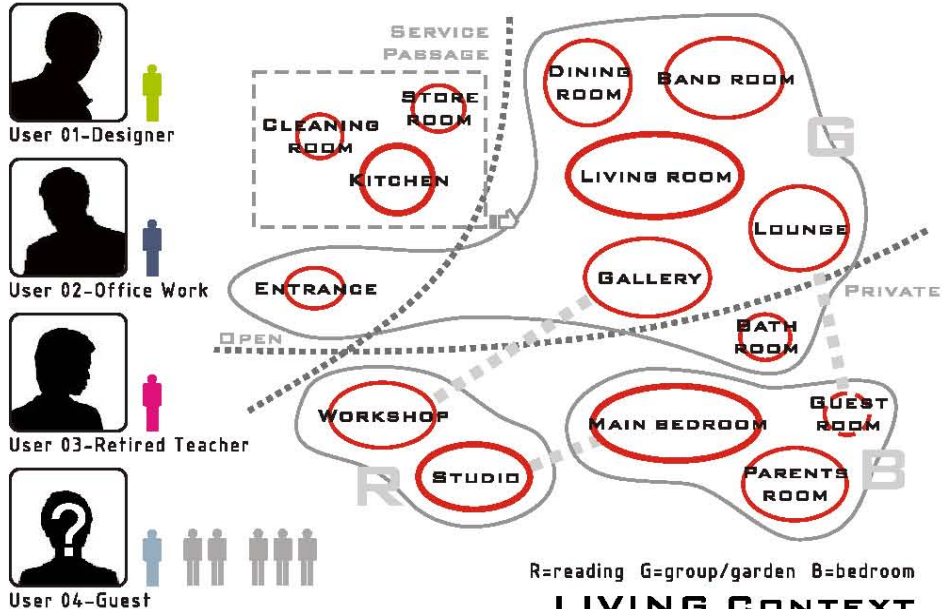

LIVING CONTEXT

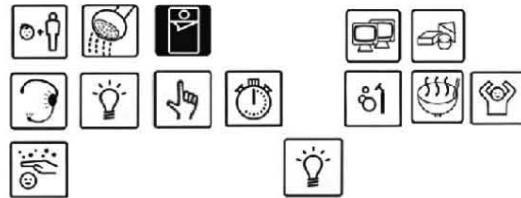

1.入口玄關 [ENTRANCE]

2.起居活動 [ACTIVITIES]

- A.會客
- B.進食
- C.休閒
- D.沐浴
- E.如廁
- F.睡覺

3.家務 [HOUSE WORK]

- A.清潔
- B.烹飪
- C.洗衣

4.工作 [WORK]

- A.閱讀
- B.電腦

5.特殊需求 [DEMAND]

- A.畫圖/模型
- B.音樂教室

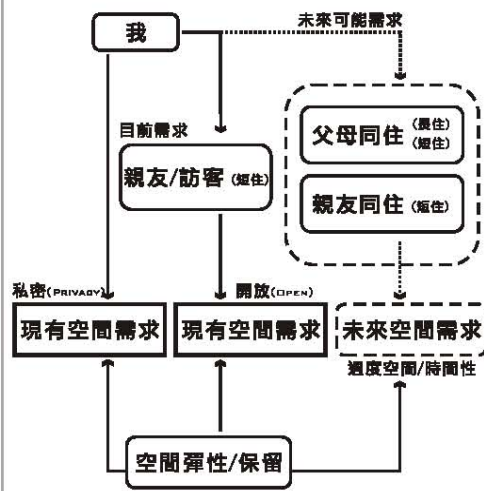



SITE CHOOSING

@Xianji Yan, Jingmei, Taipei City

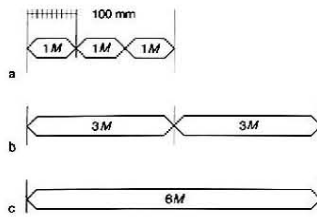

The 3mx3m mesh redefined the area. And the direction of mesh follow contour lines, for lightening conflicts between buildings and the terrain.

ORDER MESH

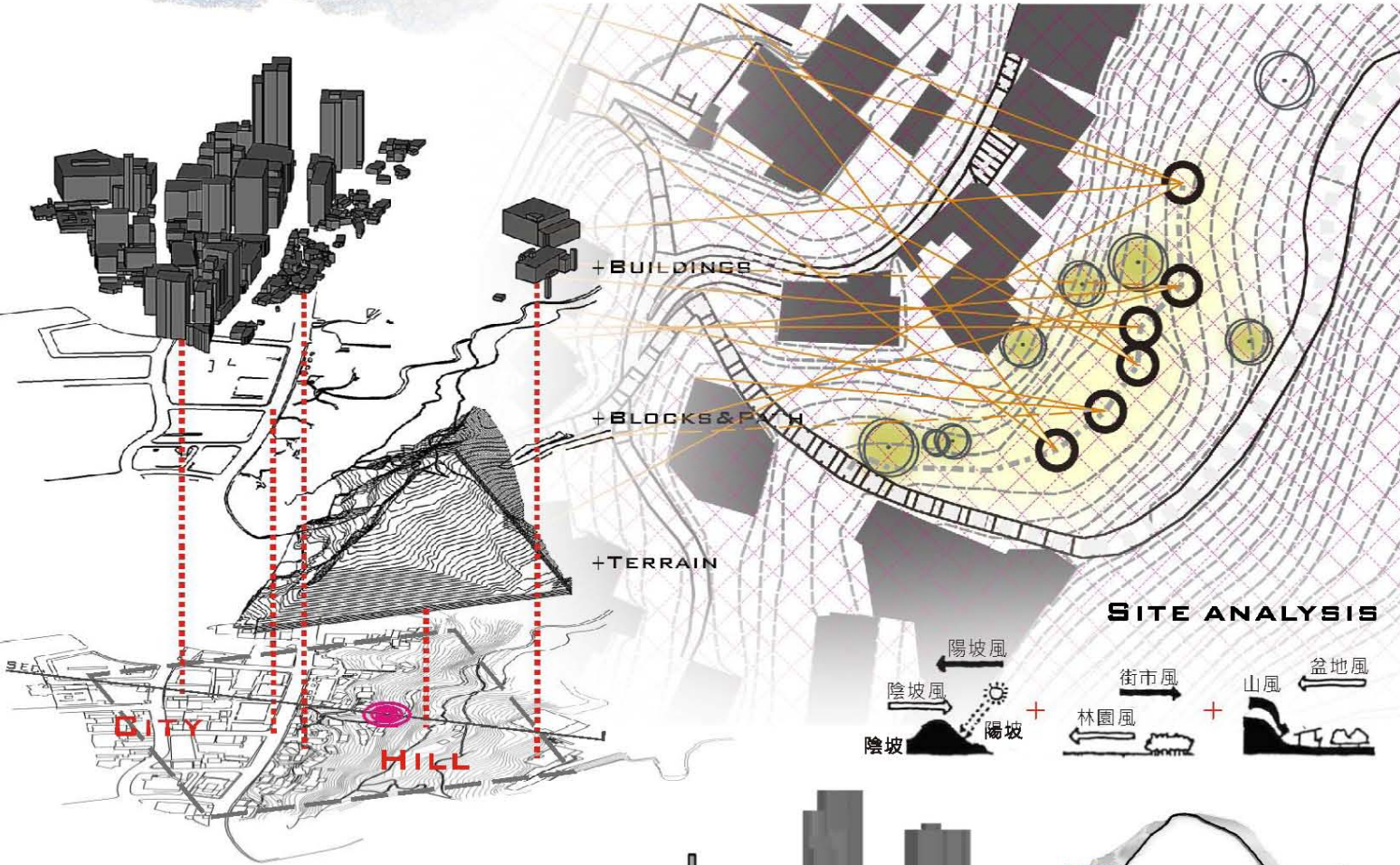

SITE MAPPING

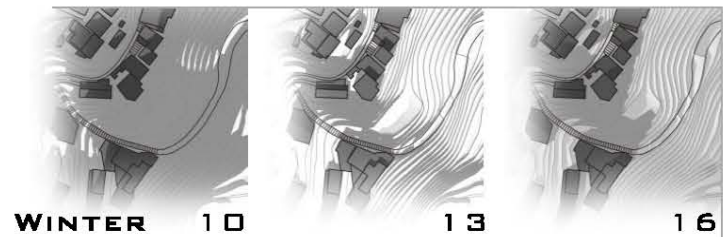
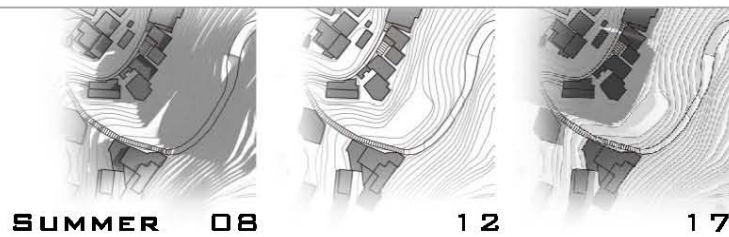
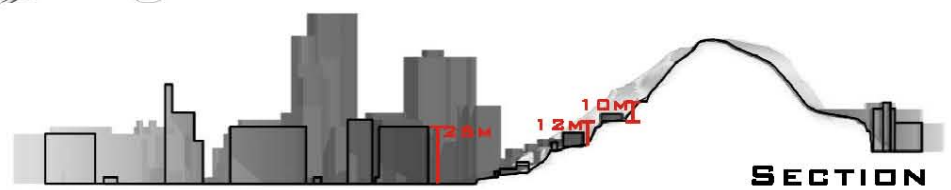



LIVING
IMAGE

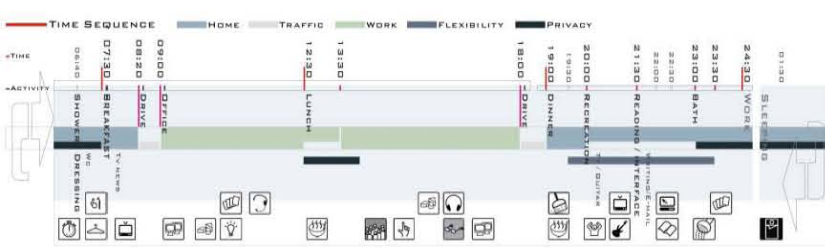

LIVING SCENARIO

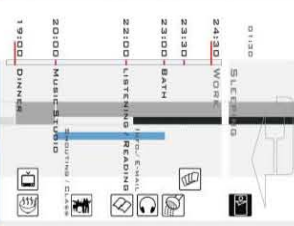
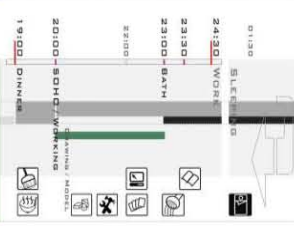
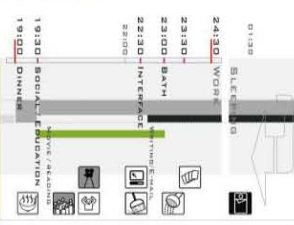

- am07:00 起床
- am07:30 早餐/看新聞或聽廣播
- am08:20 出門上班
- am09:00~pm6:00 工作
- pm07:00 之前到家，與家人共進晚餐
- pm08:00 彈吉他...散步至屋頂看天空，任思緒飄盪，遙望城市夜景，享受離開喧囂的空氣
- pm09:30 收發e-mail，瀏覽website，閱讀magazines, books...etc.
- pm11:00 梳洗
- pm11:30 靈修、記事，規劃週末
- pm12:30 睡覺

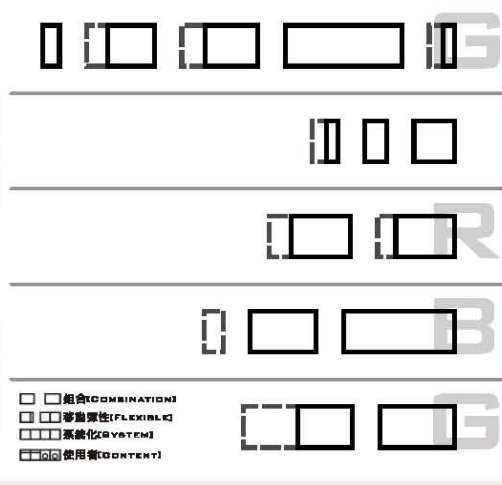

LIVING/EATING	FAMILY SPONTANEITY STABILITY
UNSTABLE SCENARIO	FLEXIBILITY VERSATILITY ADAPTABILITY
PERSONAL TIME	PRIVACY SEPARATENESS
[ENTRANCE]	[LIVING ACTIVITIES]
[HOUSE WORK]	[WORK]
[SLEEP/REST]	[OTHERS]

03-URBAN SUBCONSCIOUS PRACTICE OF SELF-DWELLING

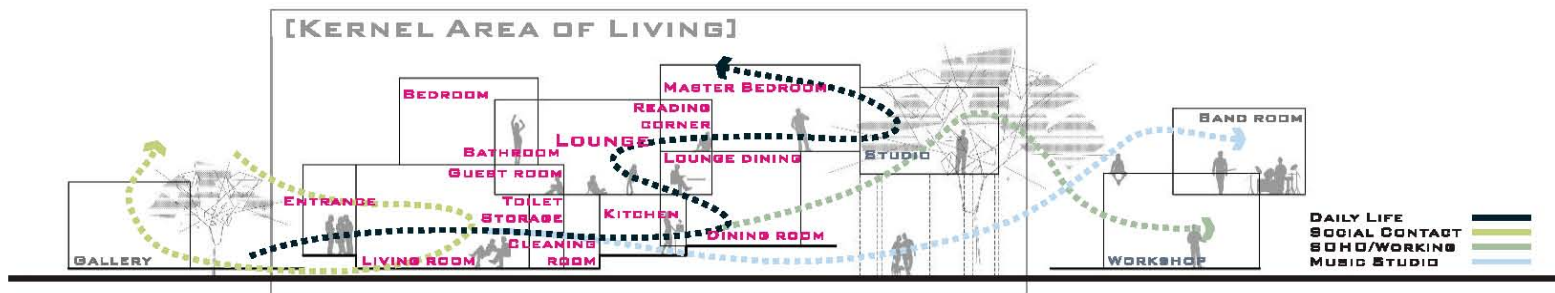
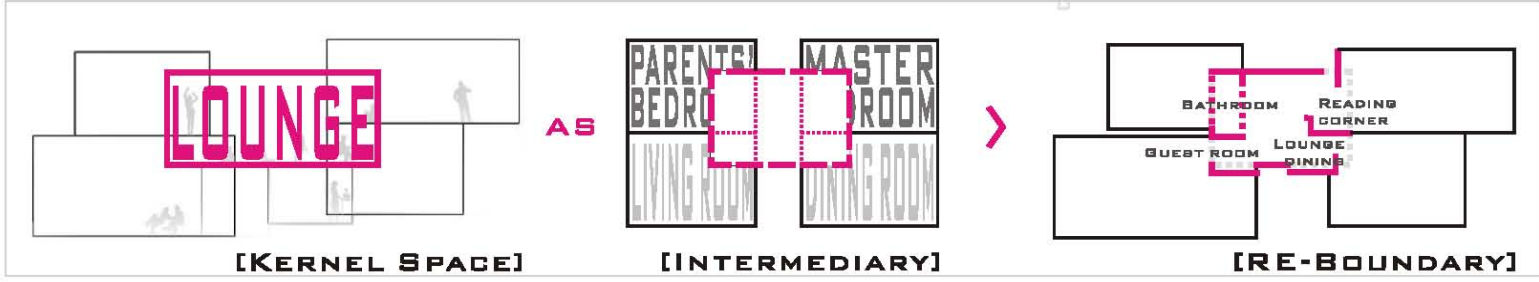
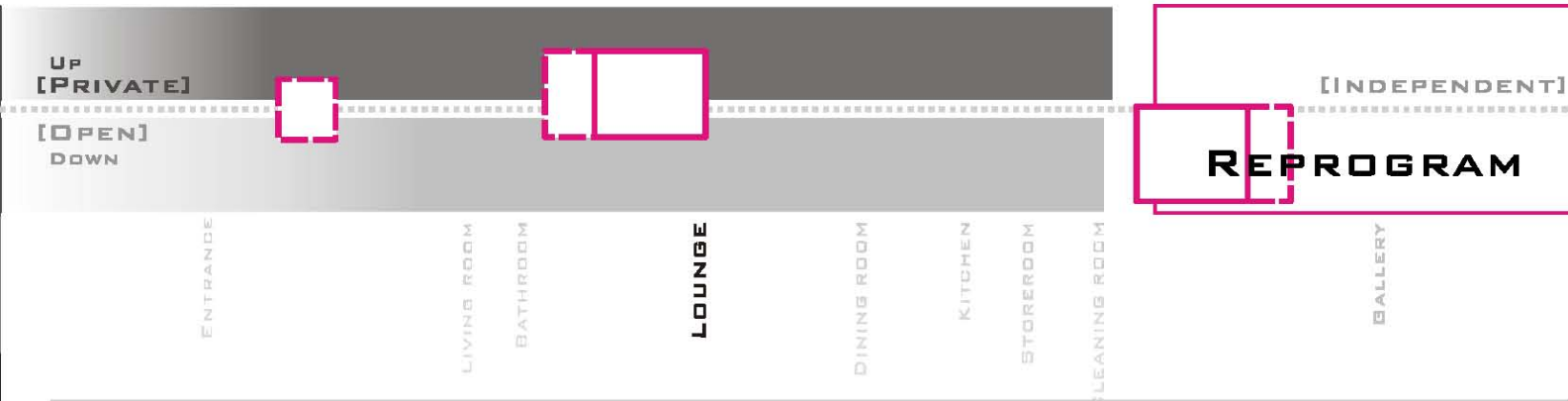
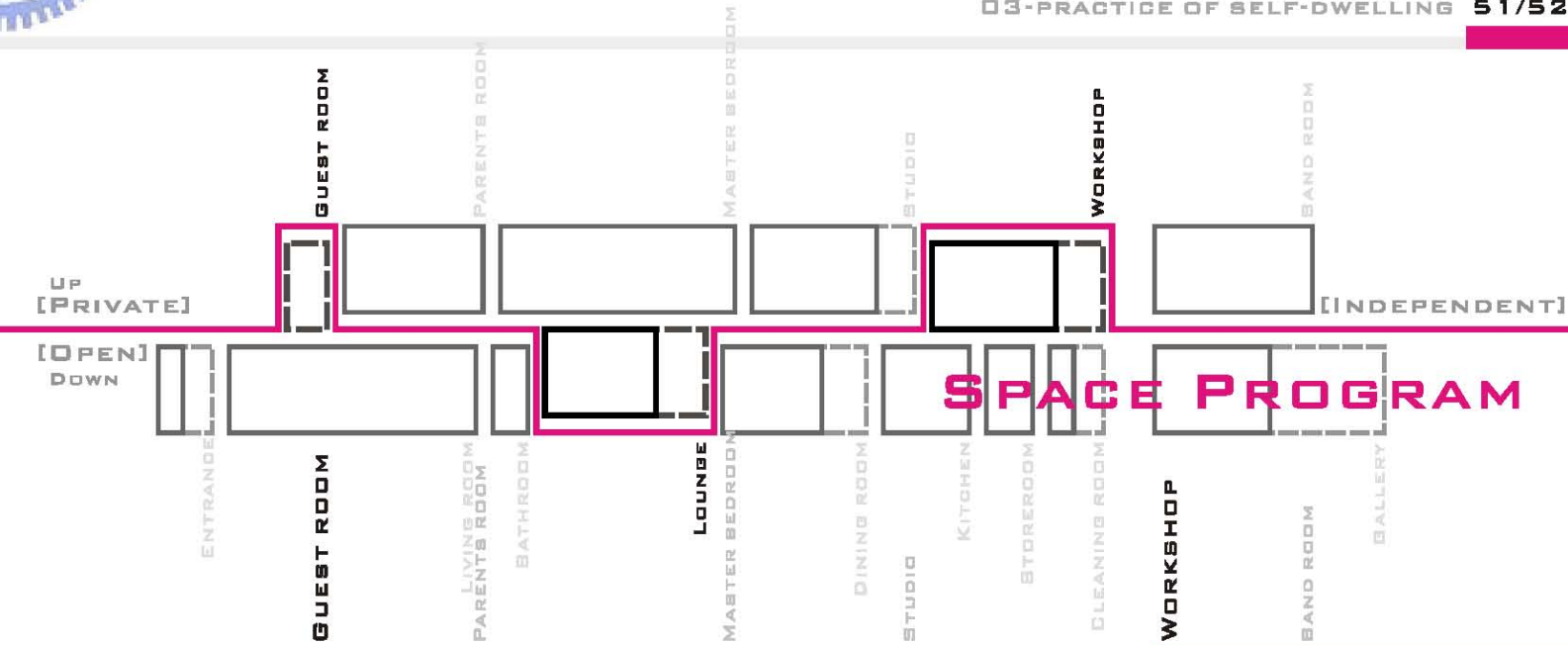

[SECTION DIAGRAM OF SPACE ADJACENCY]



RELATE TO THE GROUND

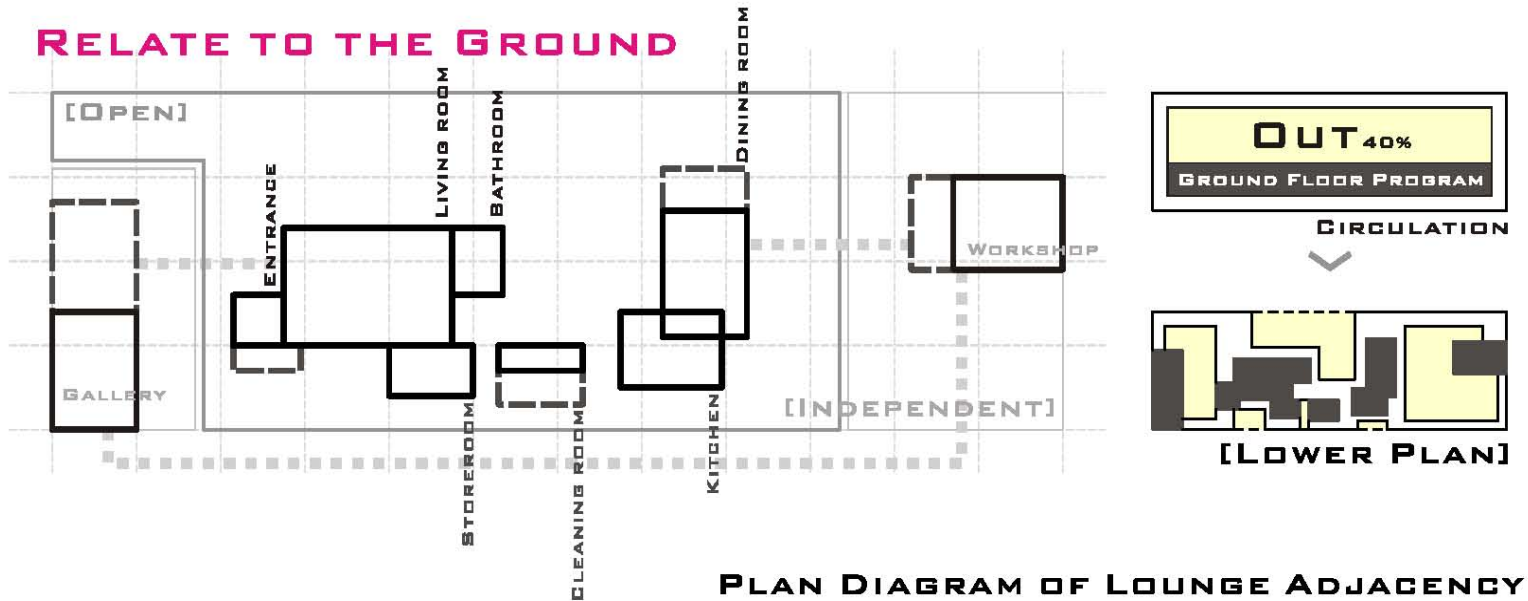

PLAN DIAGRAM OF LOUNGE ADJACENCY

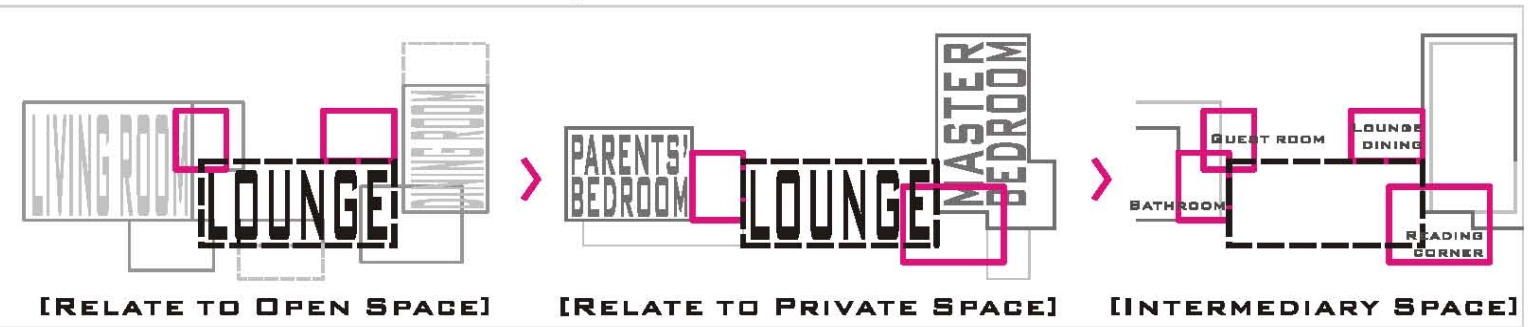

FITTING ON THE GROUND FLOOR

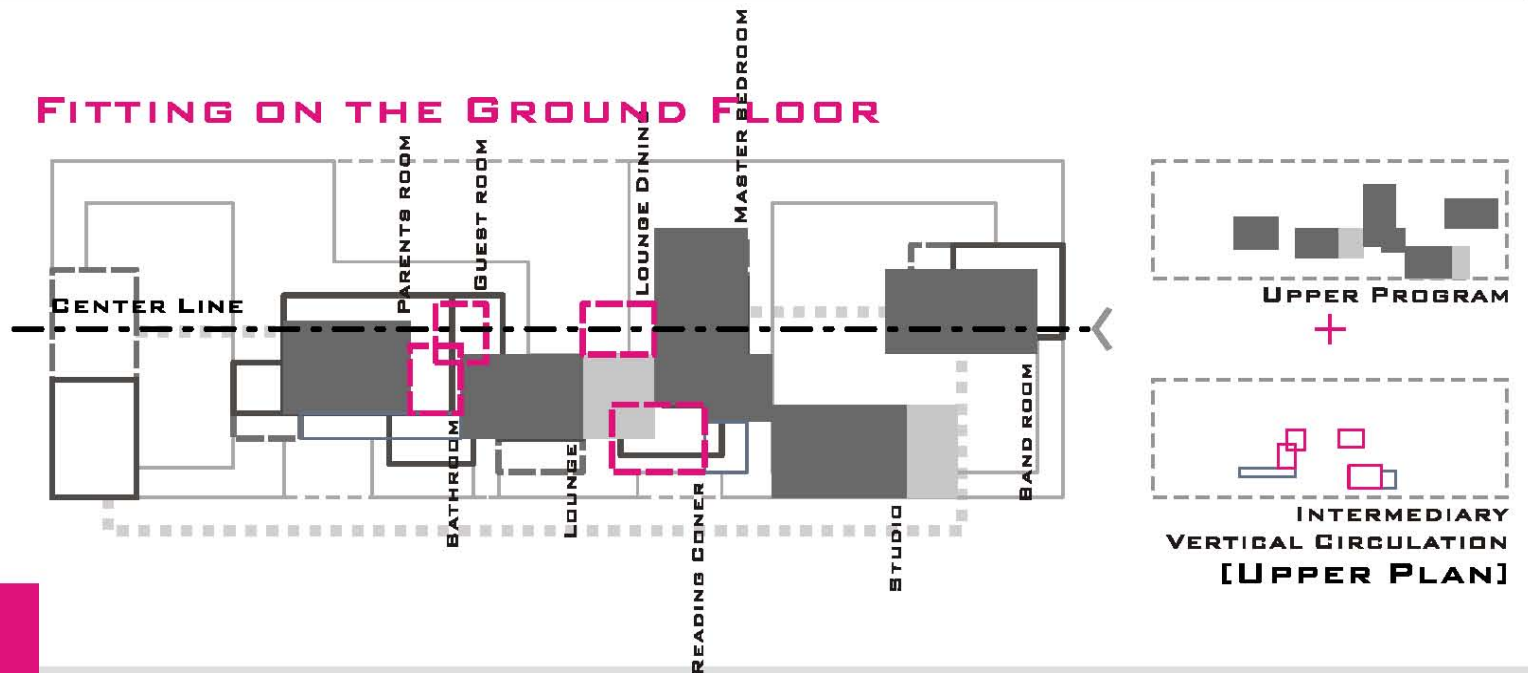

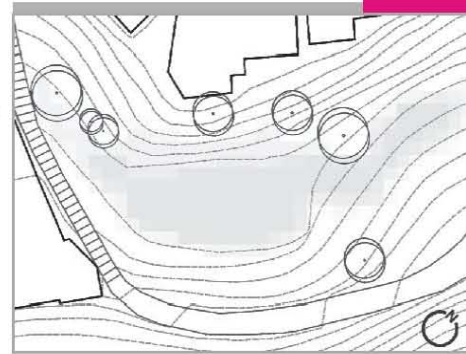
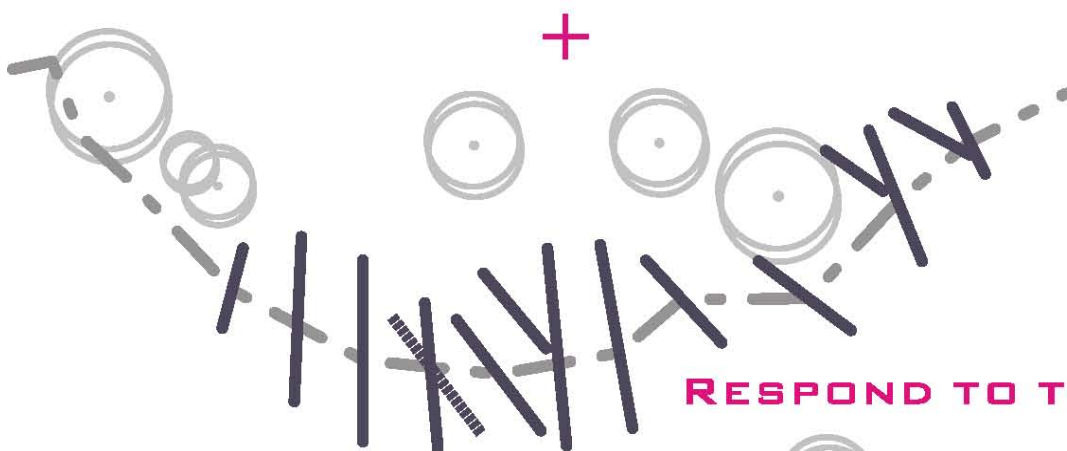

SITE AREA

RESPOND TO THE SURROUNDING

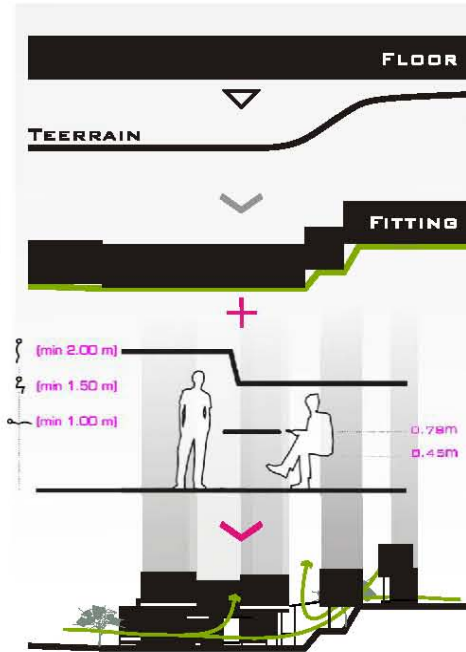
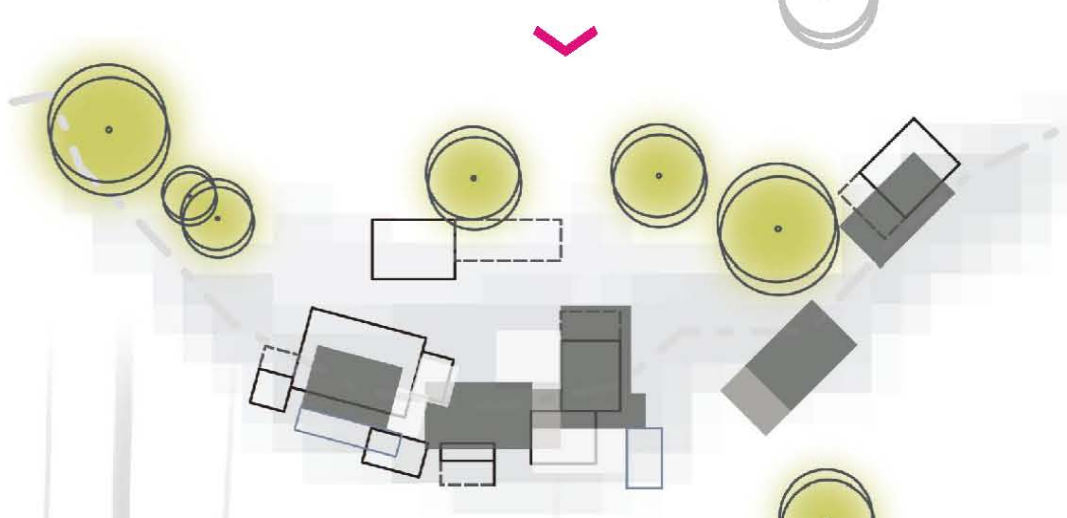

ORIENTATIONS FROM THE ENVIRONMENT
-ALONG THE TERRAIN, SURROUNDING BLOCKS, TREES
-ADJUST TO THE VIEW, NATURE LIGHT, THE WIND

TERRAIN SCHEME

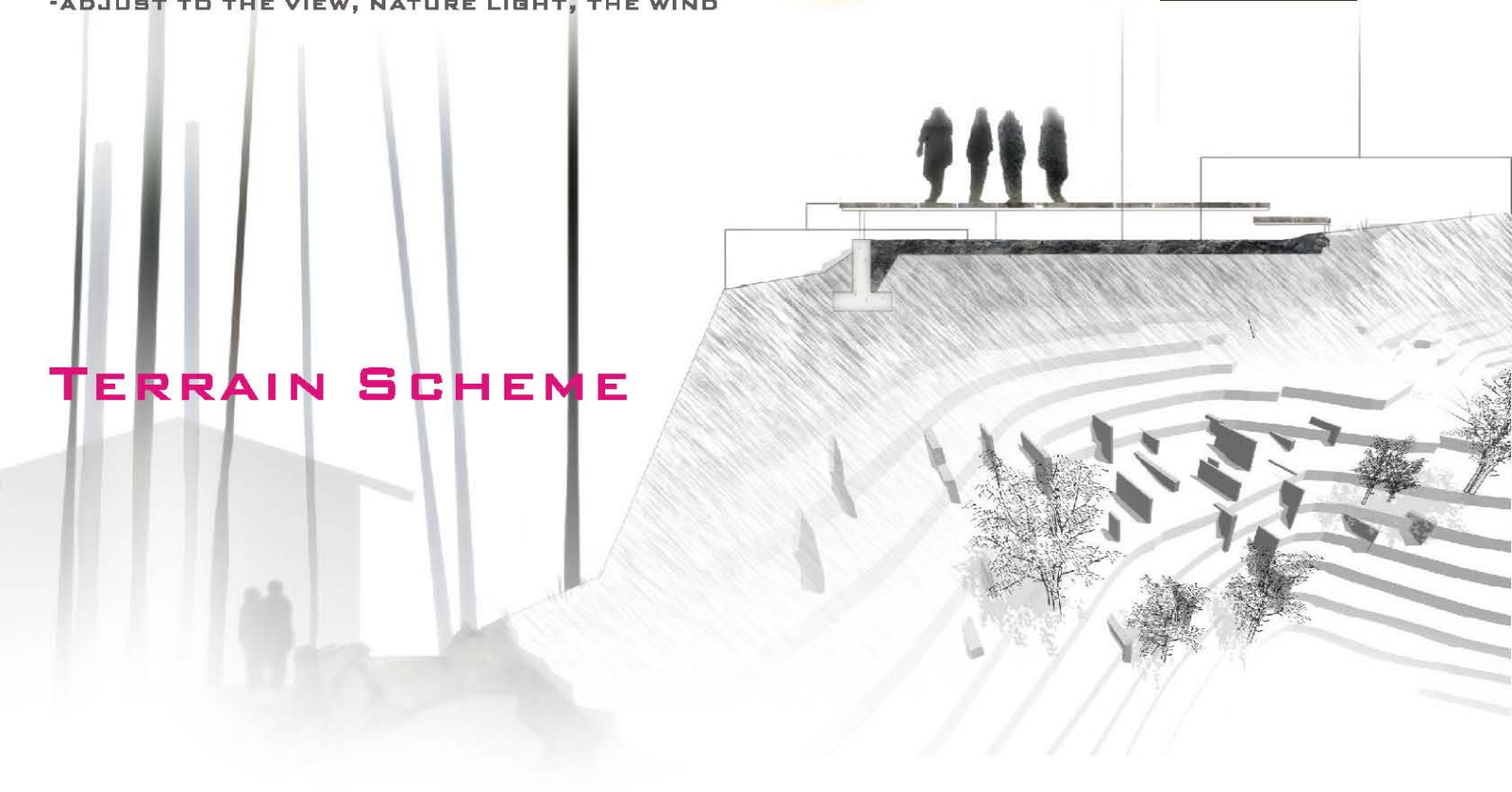



CONSTRUCTION FACADES

BLOCKS ORIENTATION

X-[SPACE] -空間單元PROGRAM

Y-[ISSUE] -活動ACTIVITY
-使用者USER

Z-[SITE] -基地、環境限制

COMPOSING ELEMENTS

EQUIPMENT
[ATTACHMENT]

SPACE
STRUCTURE
+
SURFACE

FOUNDATION
[INTERMEDIARY]

SITE

UP
[PRIVATE]
[OPEN+SERVICE]
DOWN

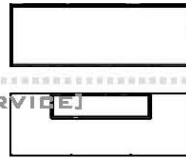

SHIELDING
TRANSPARENT

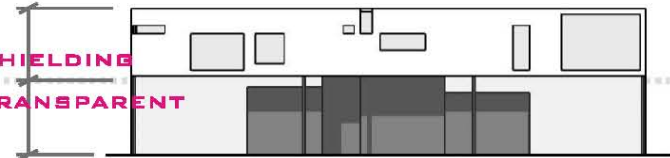

UP
[PRIVATE]
[OPEN+SERV]
DOWN



SHIELDING
TRANSPARENT



BUT



>

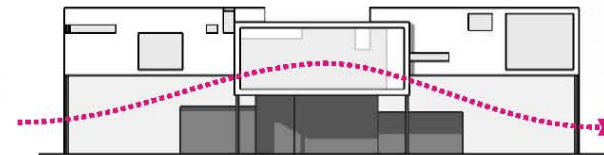

FACADES RESPOND TO THE SPACE
THE INTERMEDIARY/AMBIGUOUS SPACE - LOUNGE
WHICH EXPANDS THE OPEN SPACE
AND ACTIVITIES OF GROUPS

[FACADES RESPOND TO THE SPACE ATTRIBUTES]

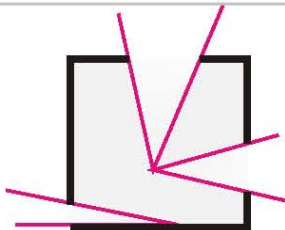

Be obscured,
But opened for bringing more lights and views.
[PRIVATE]

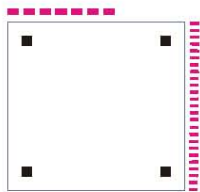

Be open and extended with virtual boundaries,
But getting shields for regulating the lights and winds.
[OPEN]

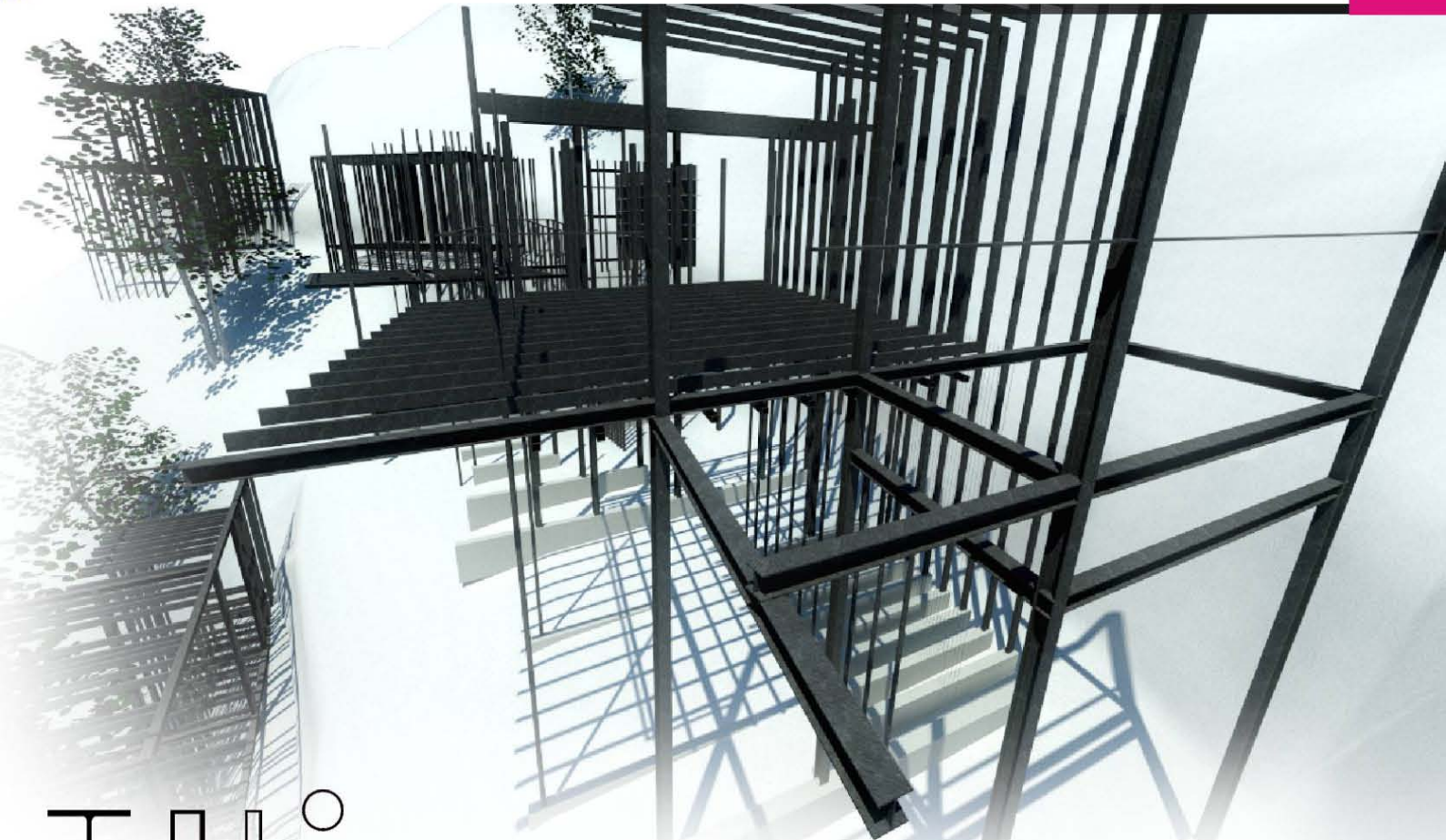

CONSTRUCTION ELEMENTS

[ESSENTIAL TYPES OF THE WALLS]

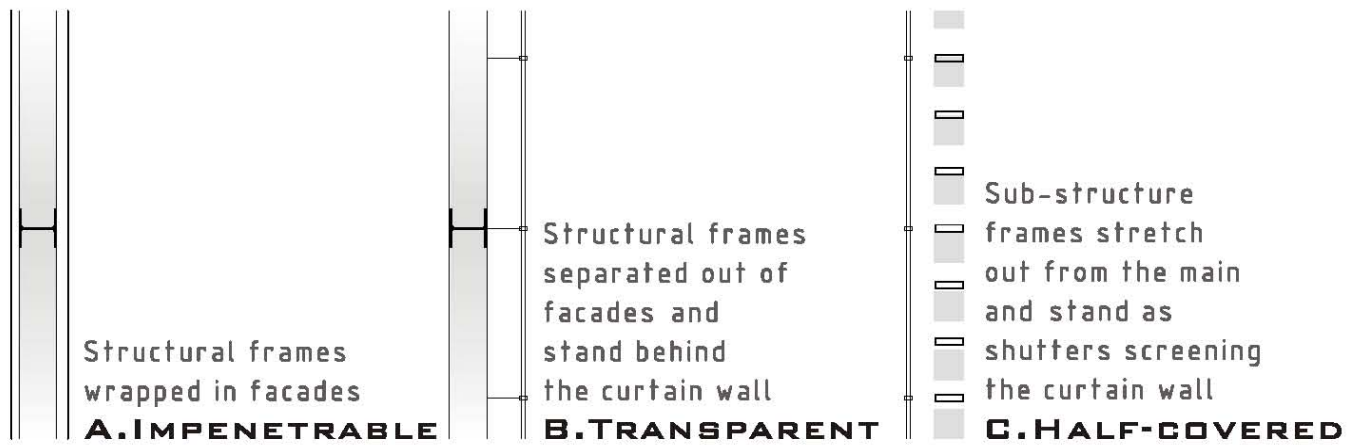



BAND ROOM

STUDIO

MASTER BEDROI

WORKSHOP

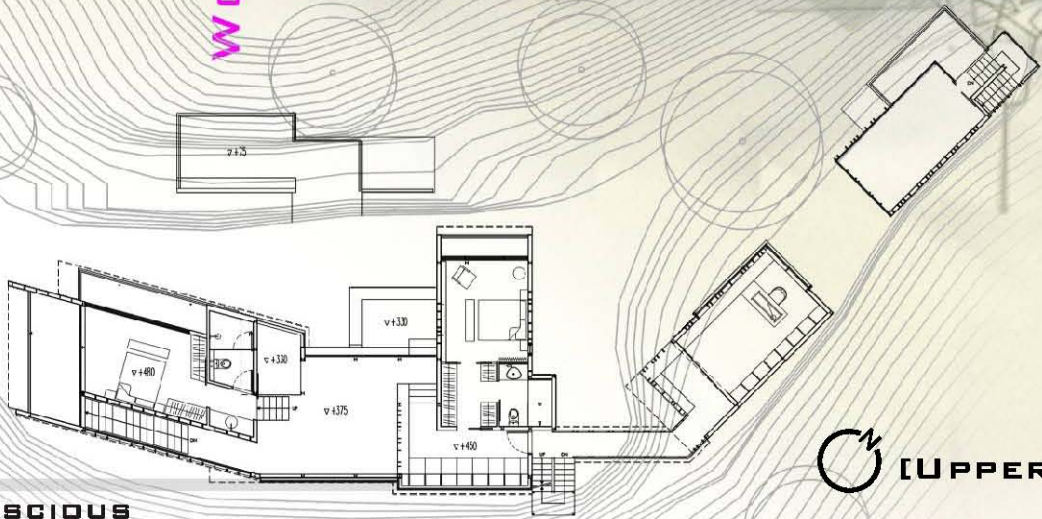

[UPPER PLAN]

03-URBAN SUBCONSCIOUS
PRACTICE OF SELF-DWELLING



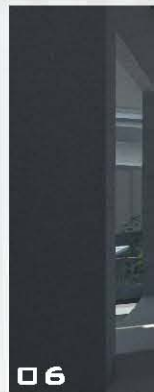
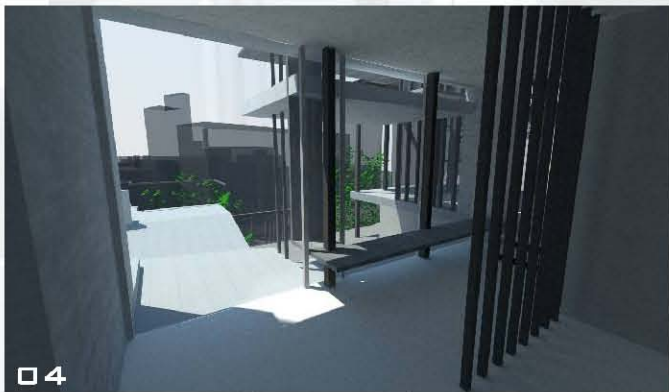
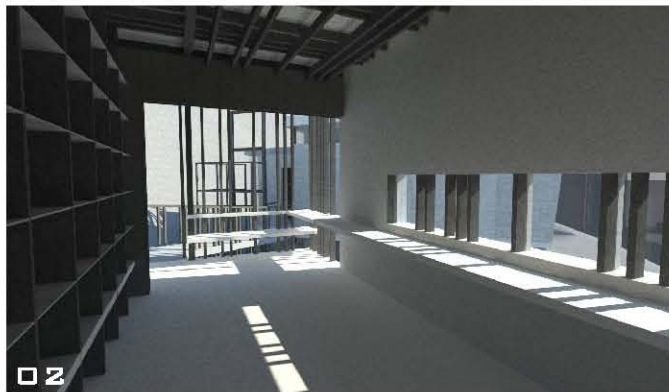

INTERIOR VIEWS

- 01-the connection to the studio
- 02-in studio
- 03/05-kernel lounge space
- 04-entrance from the courtyard
- 06-dining room
- 07/08-living room
- 09-main entrance

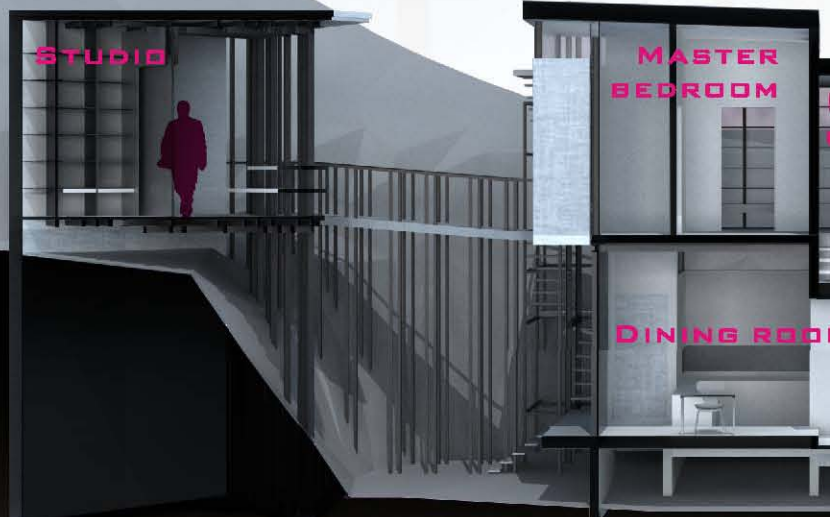

[SECTION OF KERNEL AREA]

03-URBAN SUBCONSCIOUS
PRACTICE OF SELF-DWELLING

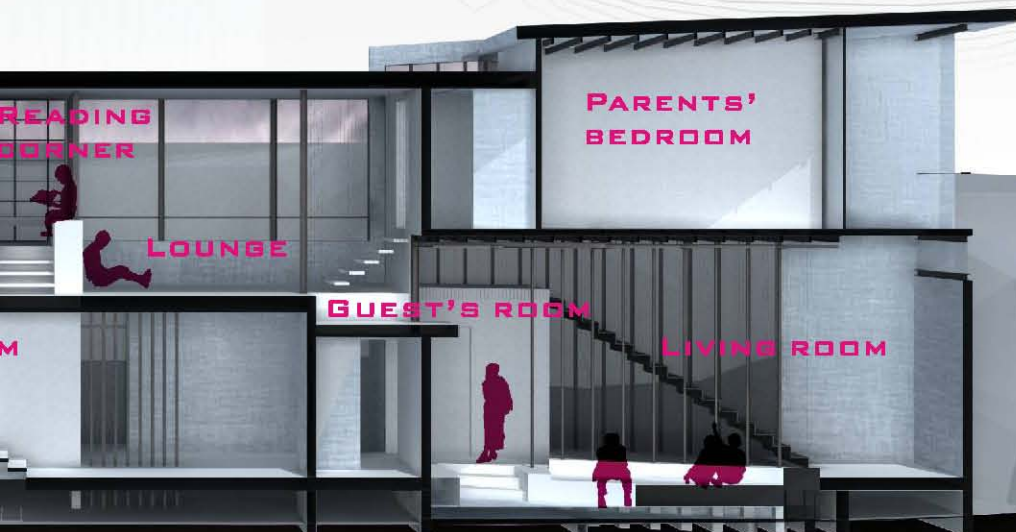
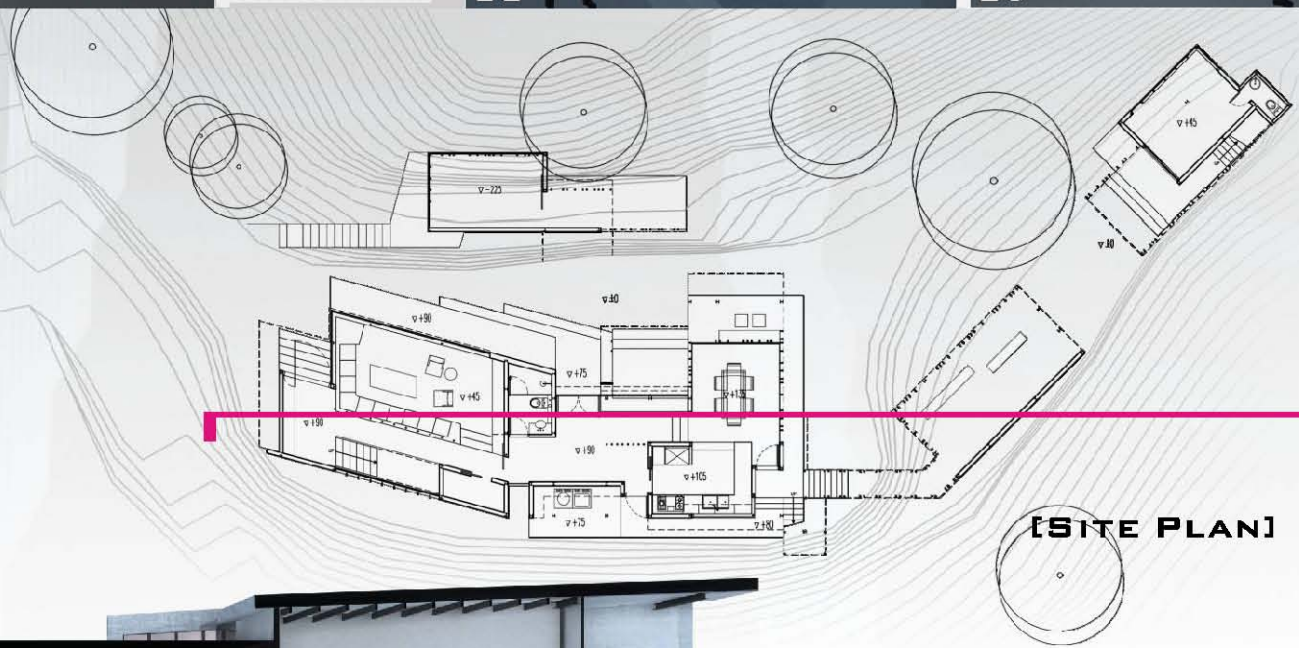
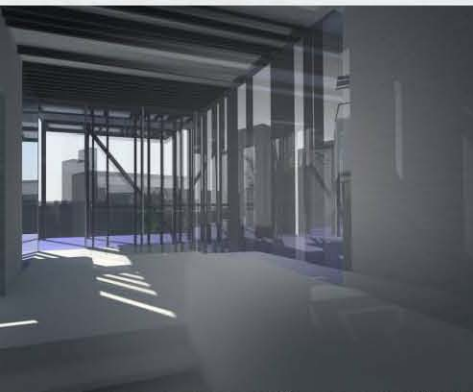



**URBAN
SUBSCONSCIOUS**
PRACTICE OF
SELF-DWELLING



**03-URBAN SUBSCONSCIOUS
PRACTICE OF SELF-DWELLING**

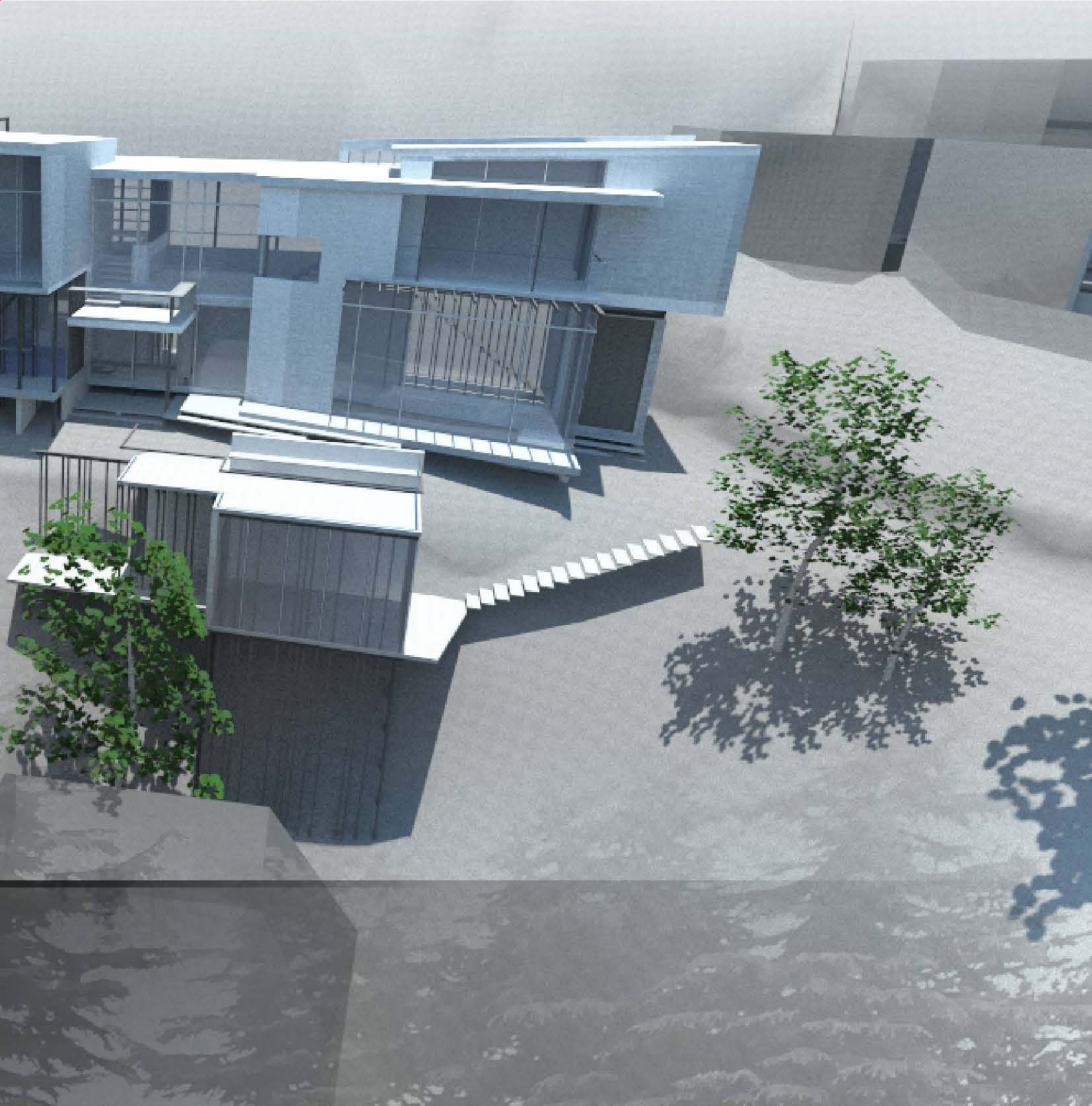



02-R

04-EMBEDDED RICH

200903-200906

ADVISOR: KUO-CHIEN SHEN

VERTICAL VILLAGE



VERTICAL SYMBOLIC OF
SPECIFIC COMMUNITY

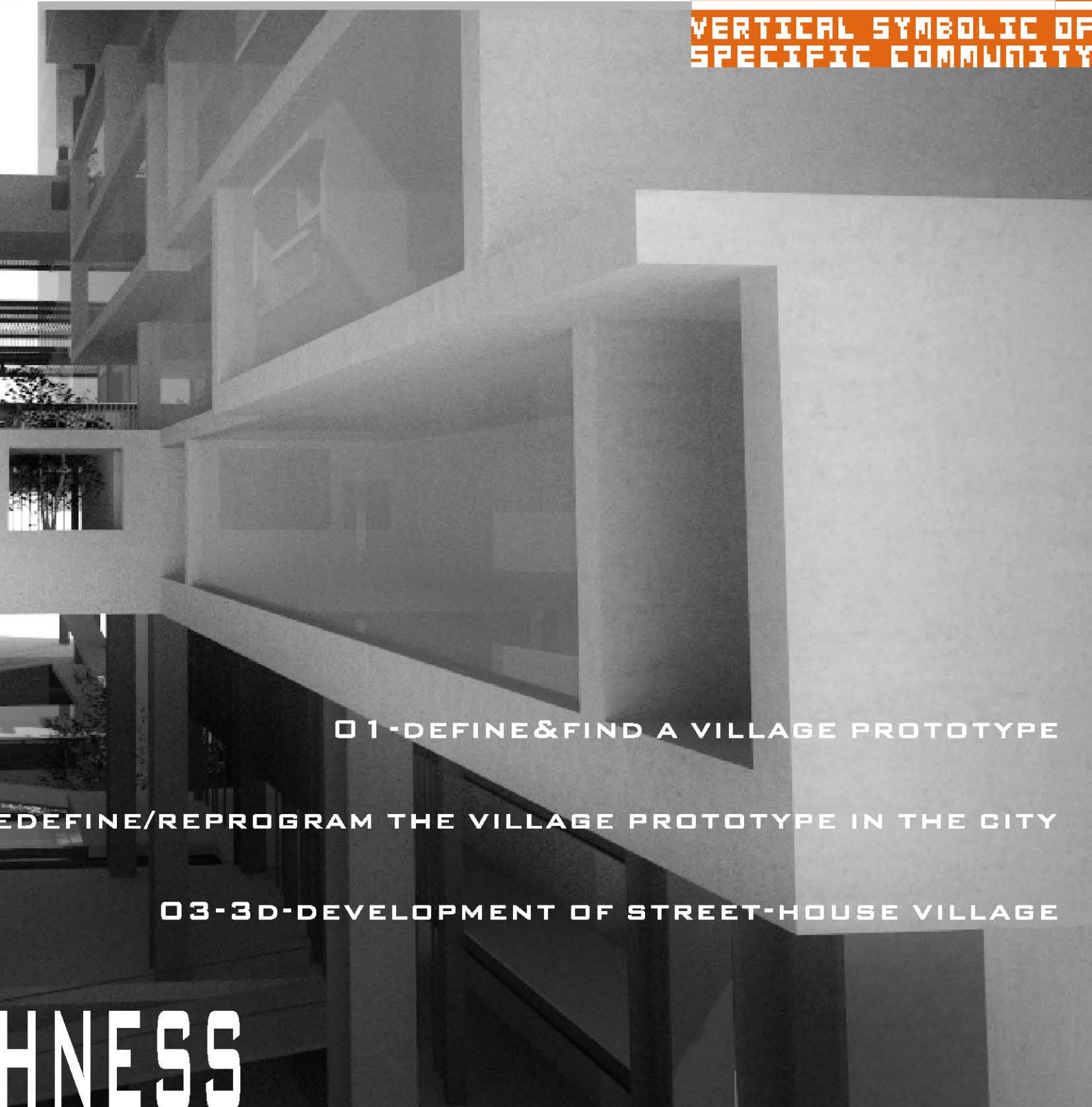

01-DEFINE&FIND A VILLAGE PROTOTYPE

02-REDEFINE/REPROGRAM THE VILLAGE PROTOTYPE IN THE CITY

03-3D-DEVELOPMENT OF STREET-HOUSE VILLAGE

PHENESS

AGE OF STREET-HOUSE



01-DEFINE&FIND A VILLAGE PROTOTYPE

This thesis is to propose a specific housing typology / vertical village that suits the high-density development of modern cities.

Village is a community of people smaller than a town.

<community> is defined as a group of interacting people living in a common location. And <communicate> is from the same origin. When changing the meaning of communication, at the same time it changed the meaning of community.

Observation of the Wu-Tiao Gang area is proceeded on private residential units, network of public articulating system and public open spaces. Focus on how this area developed and the community composition.

From the observation to propose a village prototype that contains the following points.

VILLAGE PROTOTYPE >

- MIXED-USE DEVELOPMENT
- HEAVILY INTERMINGLED COMMUNITY
- INTERACTING LIVING PROGRAMS

RELATIONSHIP OF HOUSING UNITS
WITH SEPARATED VERTICAL CIRCULATION
PRIVATE COURTYARD → PUBLIC SPACE



04-EMBEDDED RICHNESS VERTICAL VILLAGE OF STREET-HOUSE

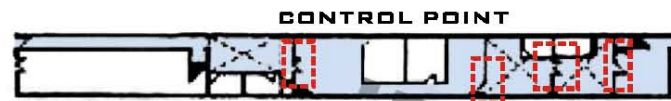
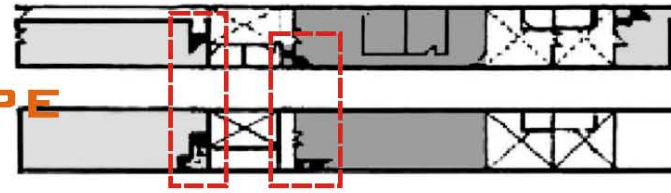

0 2 5 10M

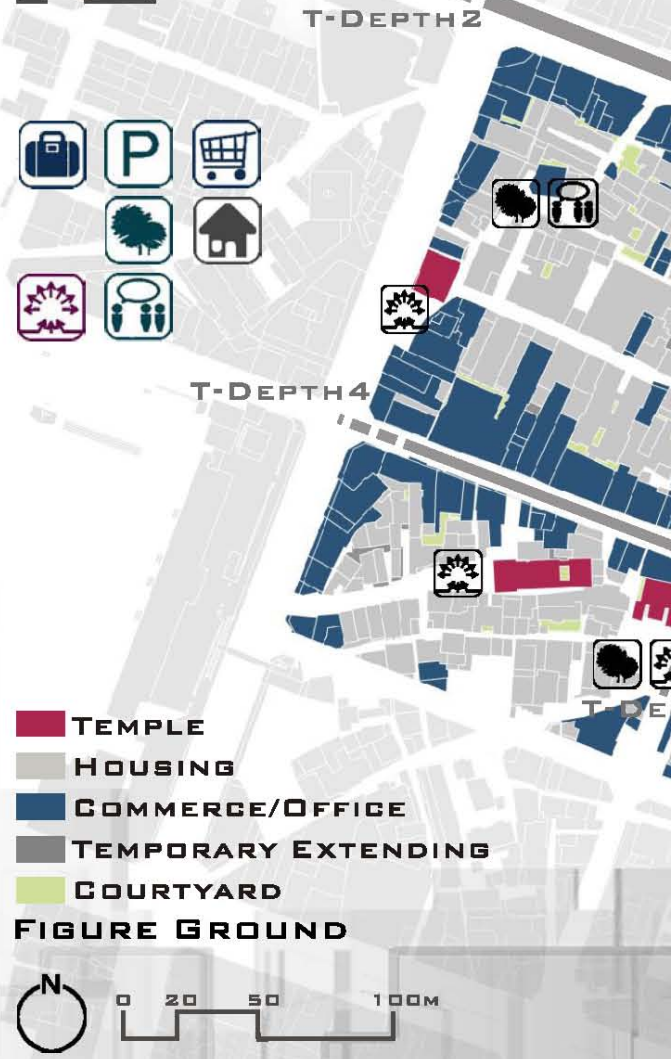

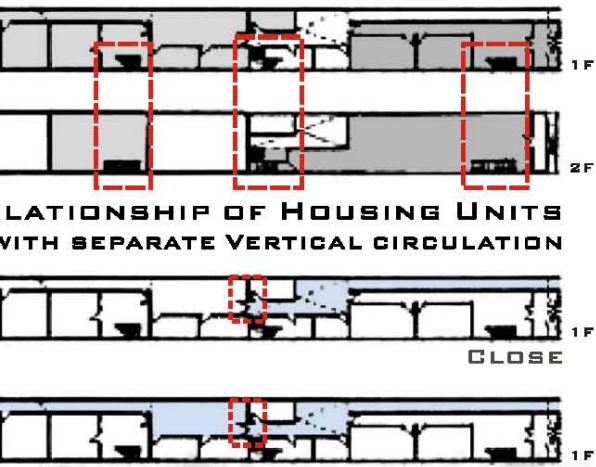

RELATIONSHIP OF HOUSING UNITS WITH SEPARATE VERTICAL CIRCULATION

INFILTRATION OF URBAN RELATIONSHIP

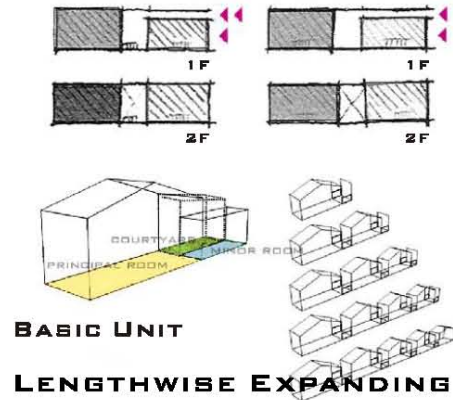

BASIC UNIT LENGTHWISE EXPANDING

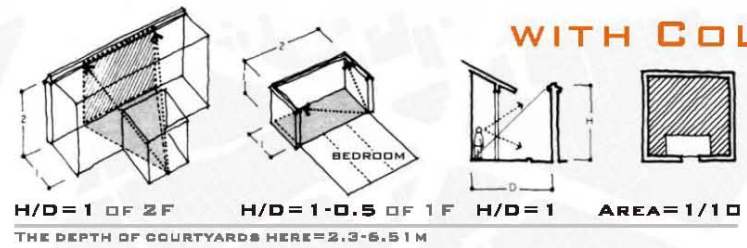

H/D=1 OF 2F H/D=1-0.5 OF 1F H/D=1 AREA=1/10 THE DEPTH OF COURTYARDS HERE=2.3-6.51M

A BUILDING TYPE WITH COURTYARD

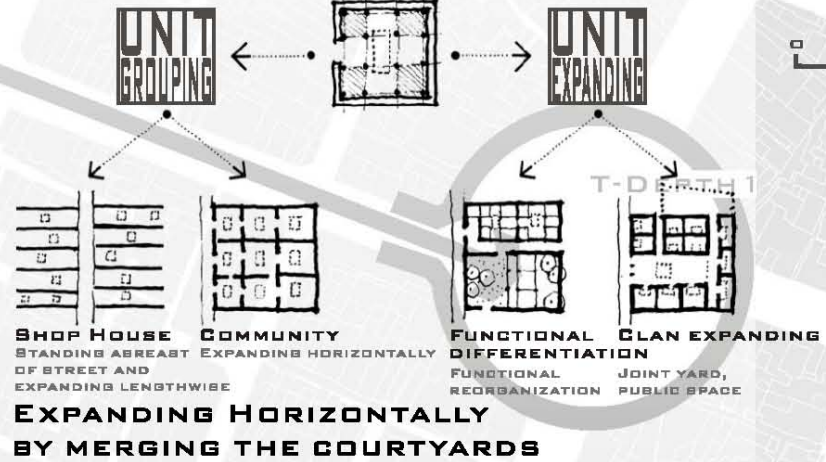

SHOP HOUSE COMMUNITY FUNCTIONAL CLAN EXPANDING
STANDING ABREAST EXPANDING HORIZONTALLY DIFFERENTIATION
EXPANDING LENGTHWISE FUNCTIONAL JOINT YARD, REORGANIZATION PUBLIC SPACE
EXPANDING HORIZONTALLY BY MERGING THE COURTYARDS

RESEARCH OF WU-TIAO GANG AREA



D=5.9M H=5-6M H/D=1.1-1.2 SEC A-A'



02-REDEFINE/REPROGRAM THE VILLAGE PROTOTYPE INN THE CITY

TREND OF URBANIZATION

High density and vertical development is a future global trend. This trend does not restrain a particular building, and it could also be applied to a colony of complicit buildings.

Monomer buildings are no longer confined to their respective development, but in series groups, sometimes overlapping staggered relationship, sometimes scattered independent.

PROGRAM VOLUME OF VILLAGE

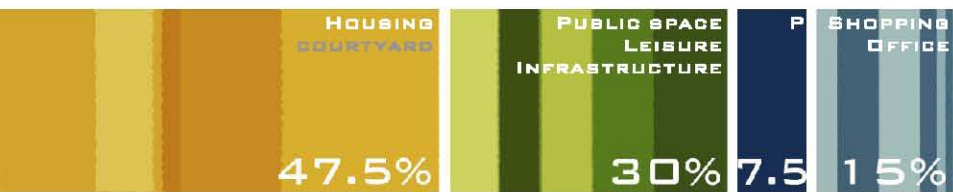

**INDEPENDENT OF MIXED-USE
INTERACTIVE UNITY
TRANSITIONAL SPACE
INNER STREETS**

+

**HIGH DENSITY/VERTICAL
INDIVIDUAL
CONCENTRATE VOLUME
FOR MORE OPEN SPACE
FLOW/MULTI-TRAFFIC**



VILLAGE ←
ORGANIC
APPROPRIATE
CLUSTERED
INTERACTIVE

← **TOWN** →
CROWDED
PATCHED
MIXED-USE
COMPLEX

NEW CITY
RE-URBAN

BACK TO VILLAGE SCALE



**04-EMBEDDED RICHNESS
VERTICAL VILLAGE OF STREET-HOUSE**



Dealing with a street-house typology in Wu-Tiao Gang area as a community prototype. According to the trend of city development, get the village programs recombination and re-classification to be appropriate placed in the city. Creating discontinuity of programs to produce both horizontal and vertical social intercourse.

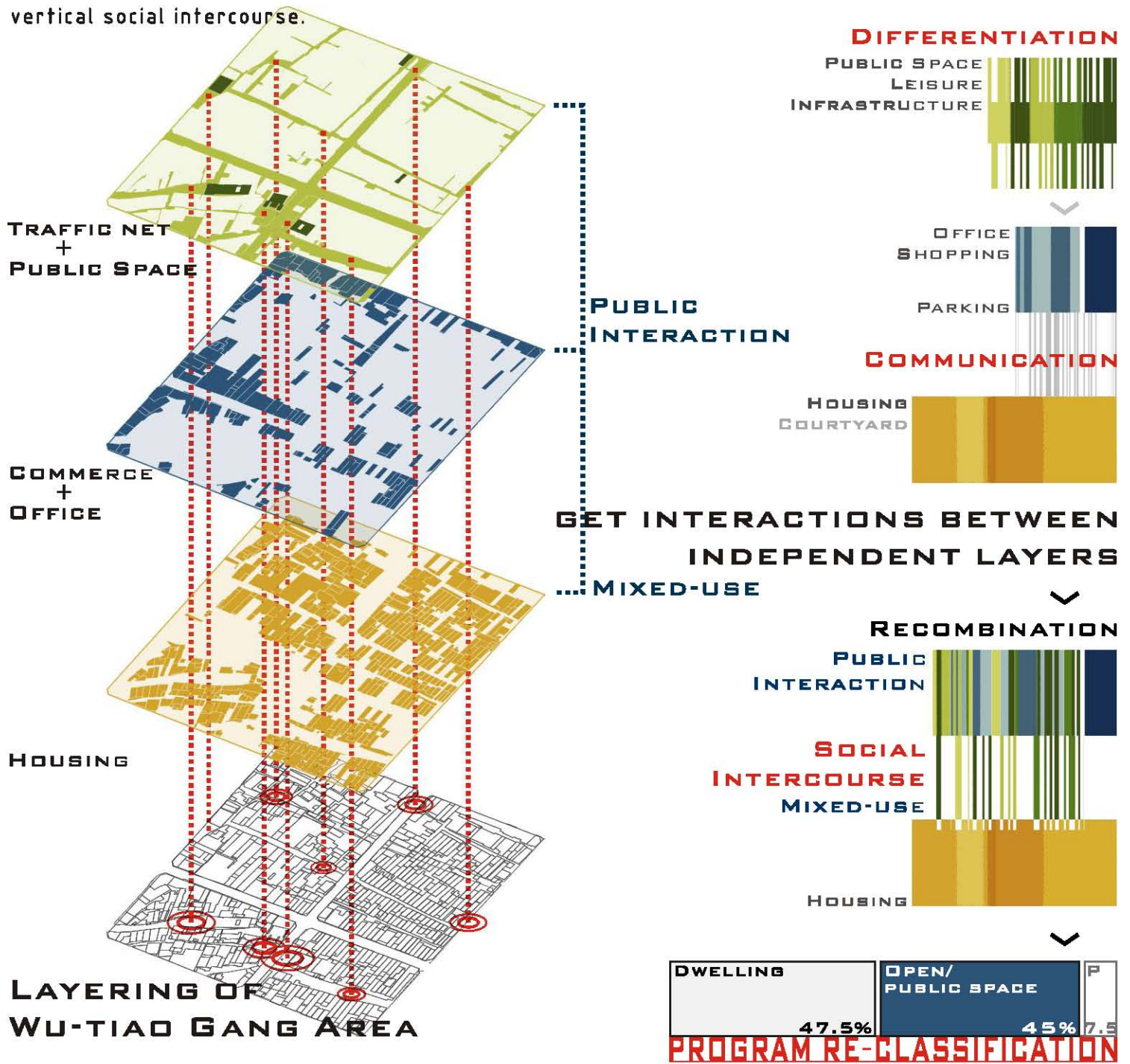



03-3D-DEVELOPMENT OF STREET-HOUSE VILLAGE

Changing the direction of development - get vertical and horizontal exchange. Not to replicate the original village, but in the same mode of development to re-express such a community relations.

CONCEPTUAL MODEL

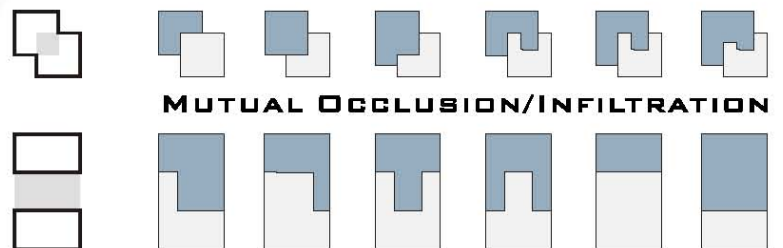
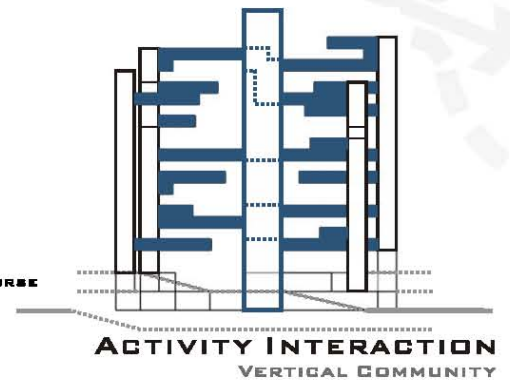
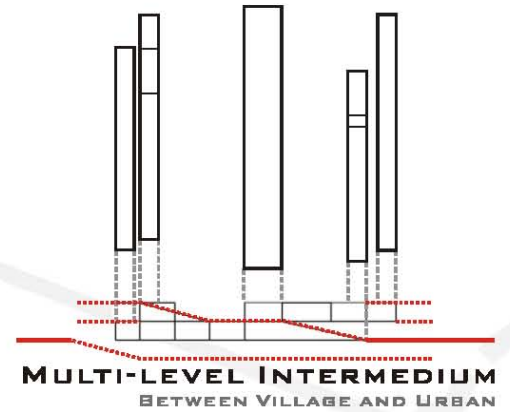
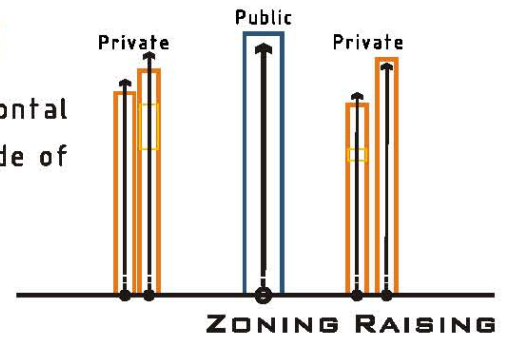
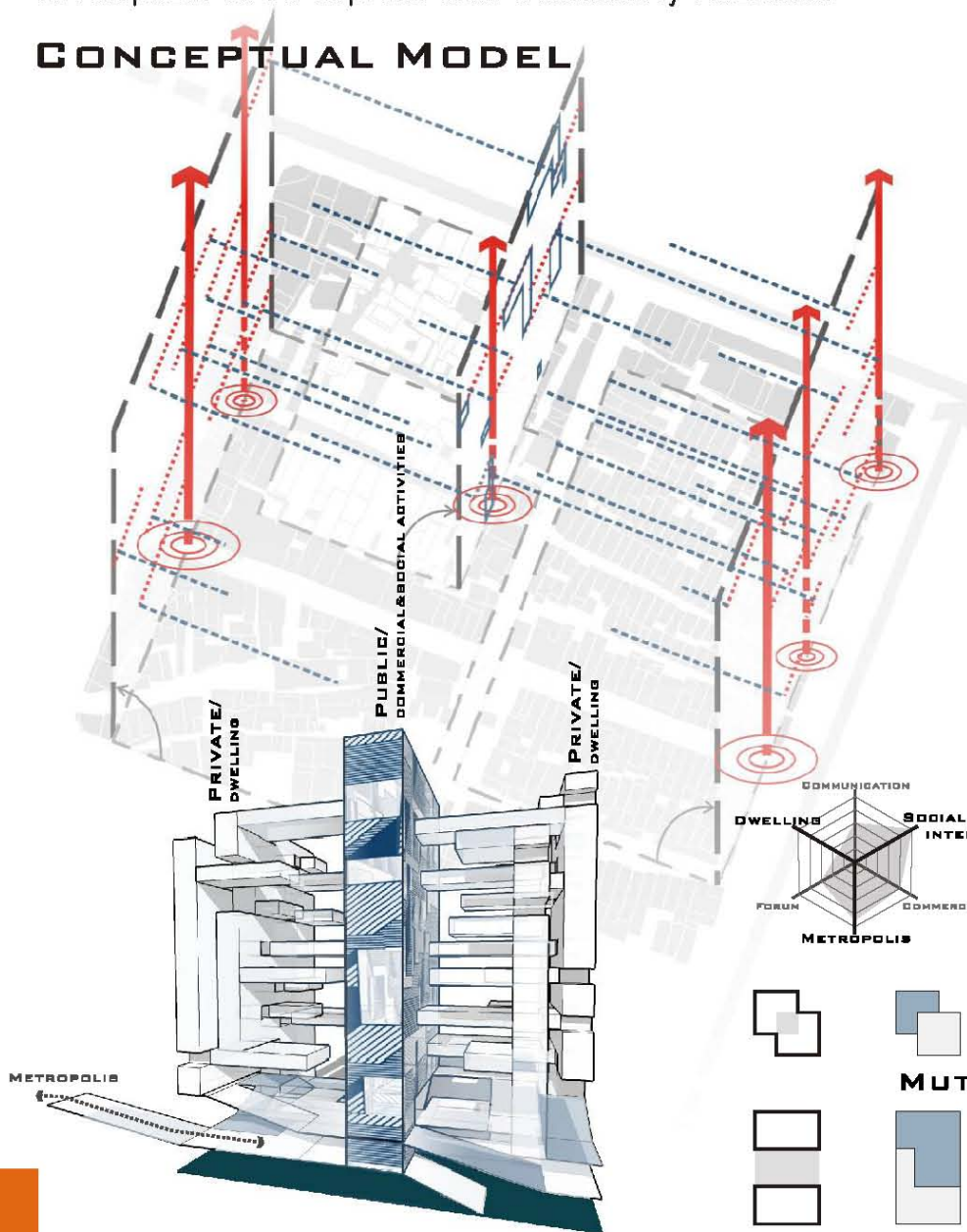

04-EMBEDDED RICHNESS VERTICAL VILLAGE OF STREET-HOUSE

Life and life, life and work,
life and entertainment, life and the city
should not be categorically divided into two

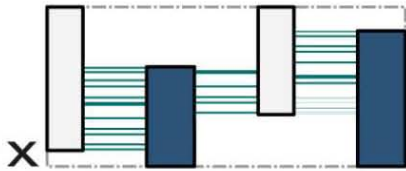

TOO SHORT AND SCATTERED

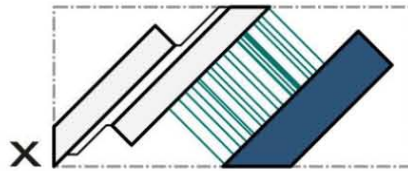

NO EFFECTIVE LAND USE

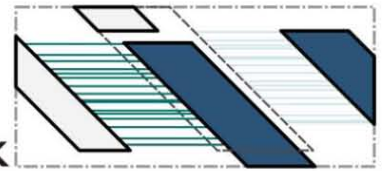

TOO SHORT ON BOTH SIDES AND MUCH ODD SPACE

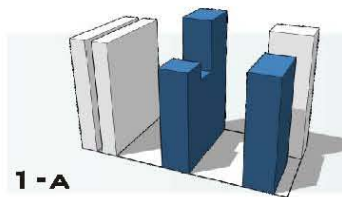
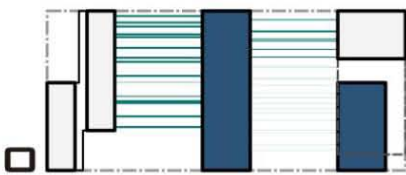

1-A

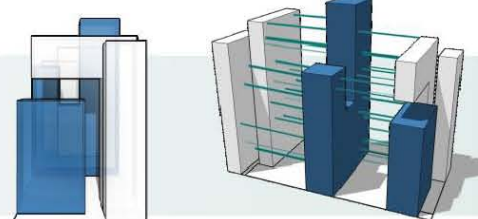

1-B

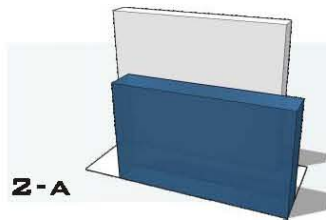

2-A

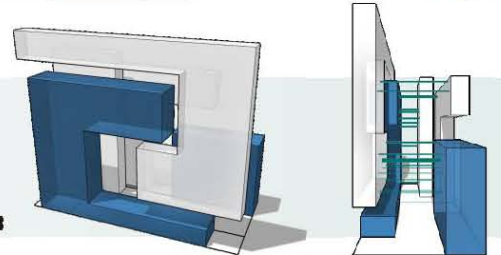

2-B

A. SIMPLE ZONING RAISING

B. COMPLEX OVERLAPPING /DIFFERENTIATION

SITE PLAN DEVELOPMENT

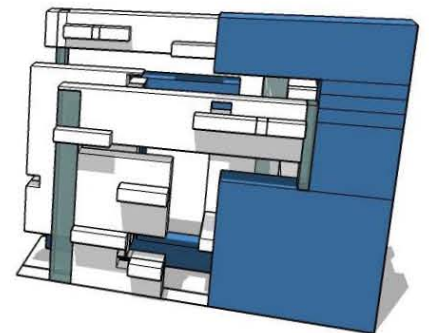
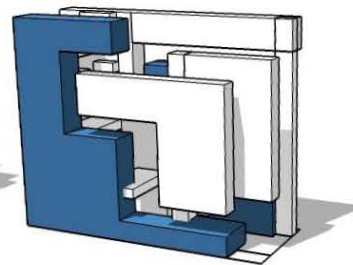
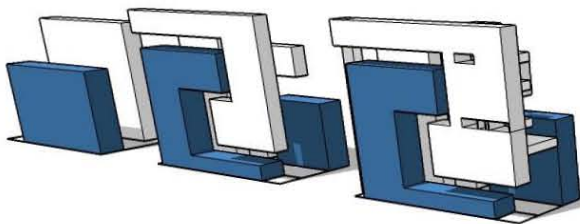

SITE CONDITION

PLOT SIZE: 90M X 40M
(3M SIDEWALK ALONG TWO SIDES)



Focus on identifying the relationship of high-density housing-solid/void, private/public and individuality/unity. Attempt to set several mass combinations basing on the site condition and find a construction form to realize it.



DESIGN OPERATION

A. A BUILDING TYPE WITH COURTYARD

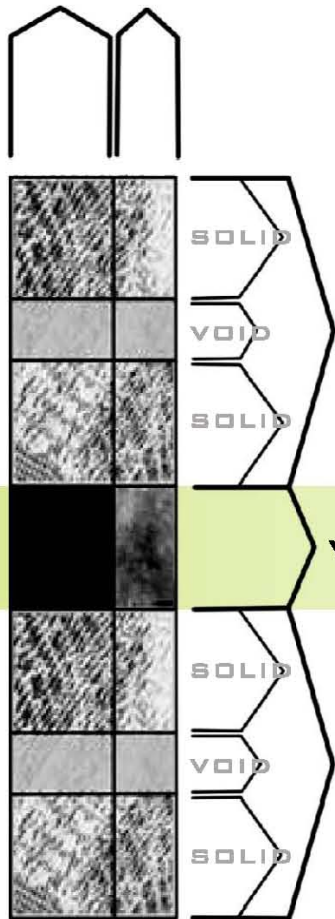

From horizontal planning,
the depth of courtyard better
bigger than 3.6m.

SOLID

But when the expanding turn to go vertically,
the courtyard must be redefined.

VOID

NEW DEPTH OF COURTYARD
MIN= 1.2M

SOLID

As a definition between
the two or
transition space
in one household

VOID

SOLID

SOLID

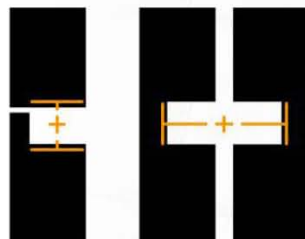
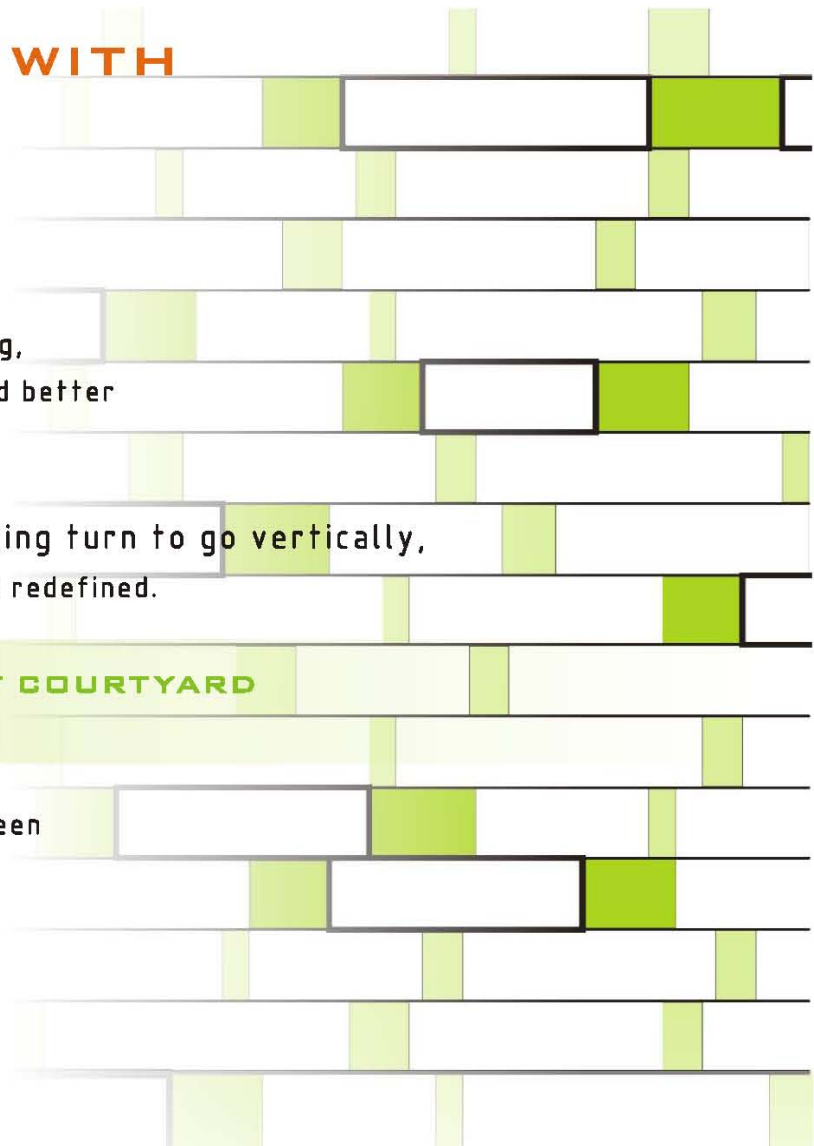

REDEFINE THE COURTYARD

EXPANDING HORIZONTALLY BY
MERGING THE COURTYARDS



EXPANSION OF BASIC UNIT

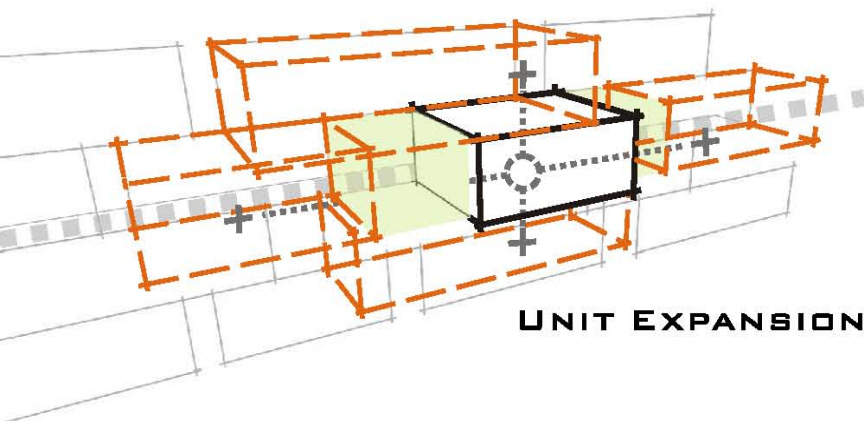

UNIT EXPANSION

MODULAR PLAN

	7.8M	11.4M	13.8M
4.5M			
5.4M			
6.3M			



B. INFILTRATION OF URBAN RELATIONSHIP

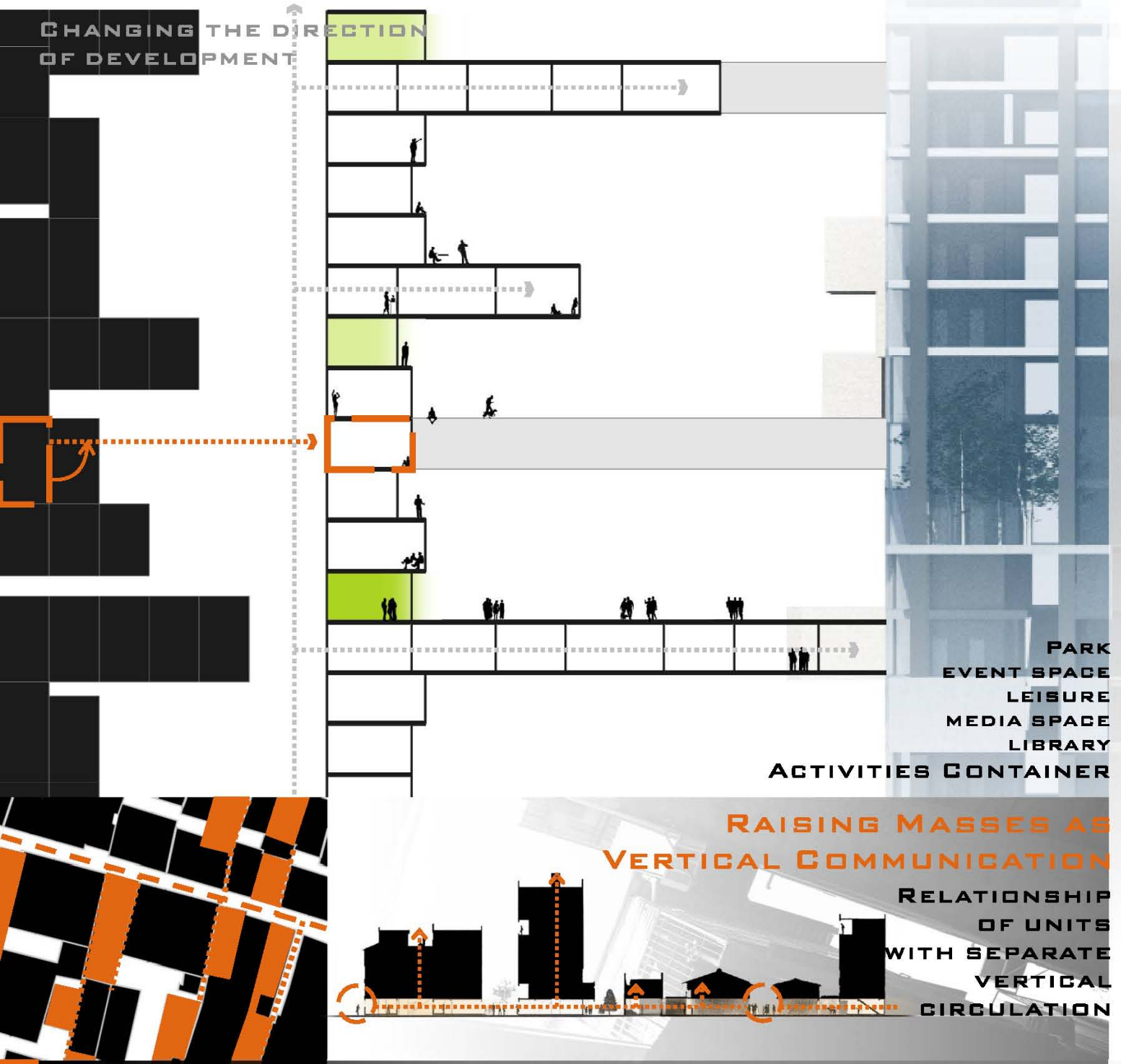

Q4-EMBEDDED RICHNESS
VERTICAL VILLAGE OF STREET-HOUSE

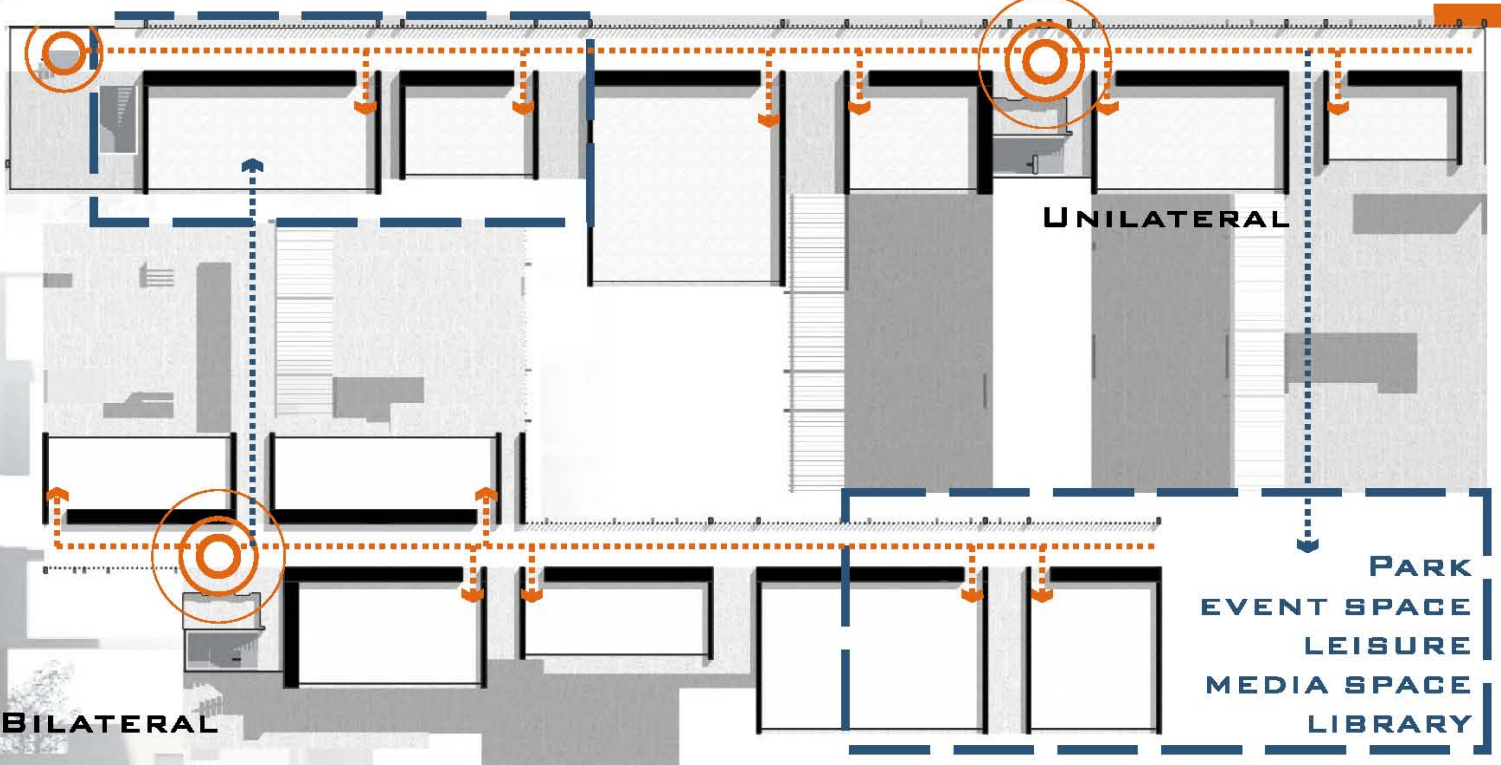

SOCIAL INTERCOURSE

**3D-NETWORK OF
PUBLIC ARTICULATING
SYSTEM**

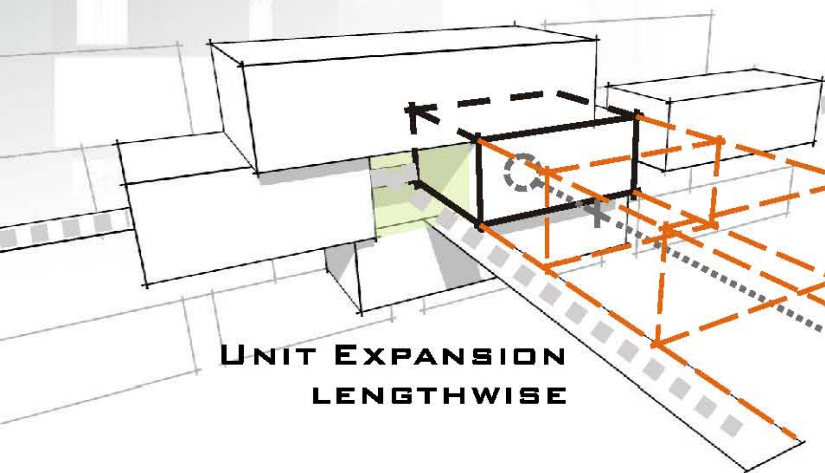
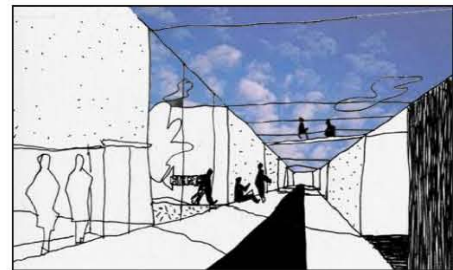
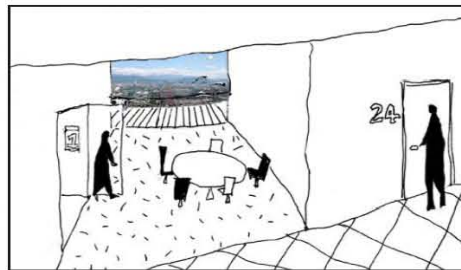

**UNIT EXPANSION
LENGTHWISE**

MODULAR PLAN

	7.8M	11.4M	13.8M
4.5M			
5.4M			
6.3M			



C. TRANSITION OF INTERMEDIUM SITE PLAN-GET CONNECT TO THE CITY

METROPOLIS VILLAGE MASS

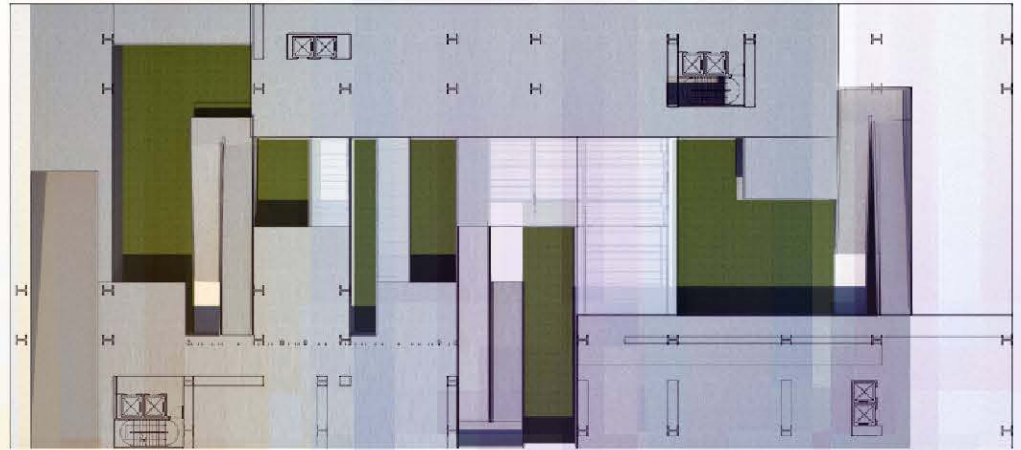
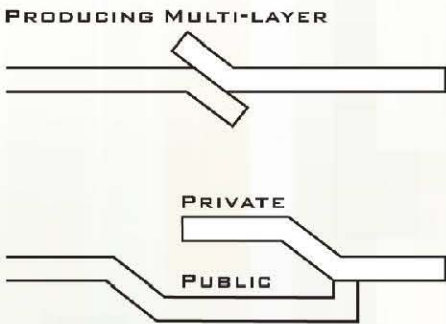

RE-ALLOCATION OF TRAFFIC



04-EMBEDDED RICHNESS
VERTICAL VILLAGE OF STREET-HOUSE





SOCIAL PROGRAMS > BUILDING FACADE

RESPOND TO THE
TOUCHING WITH DWELLING

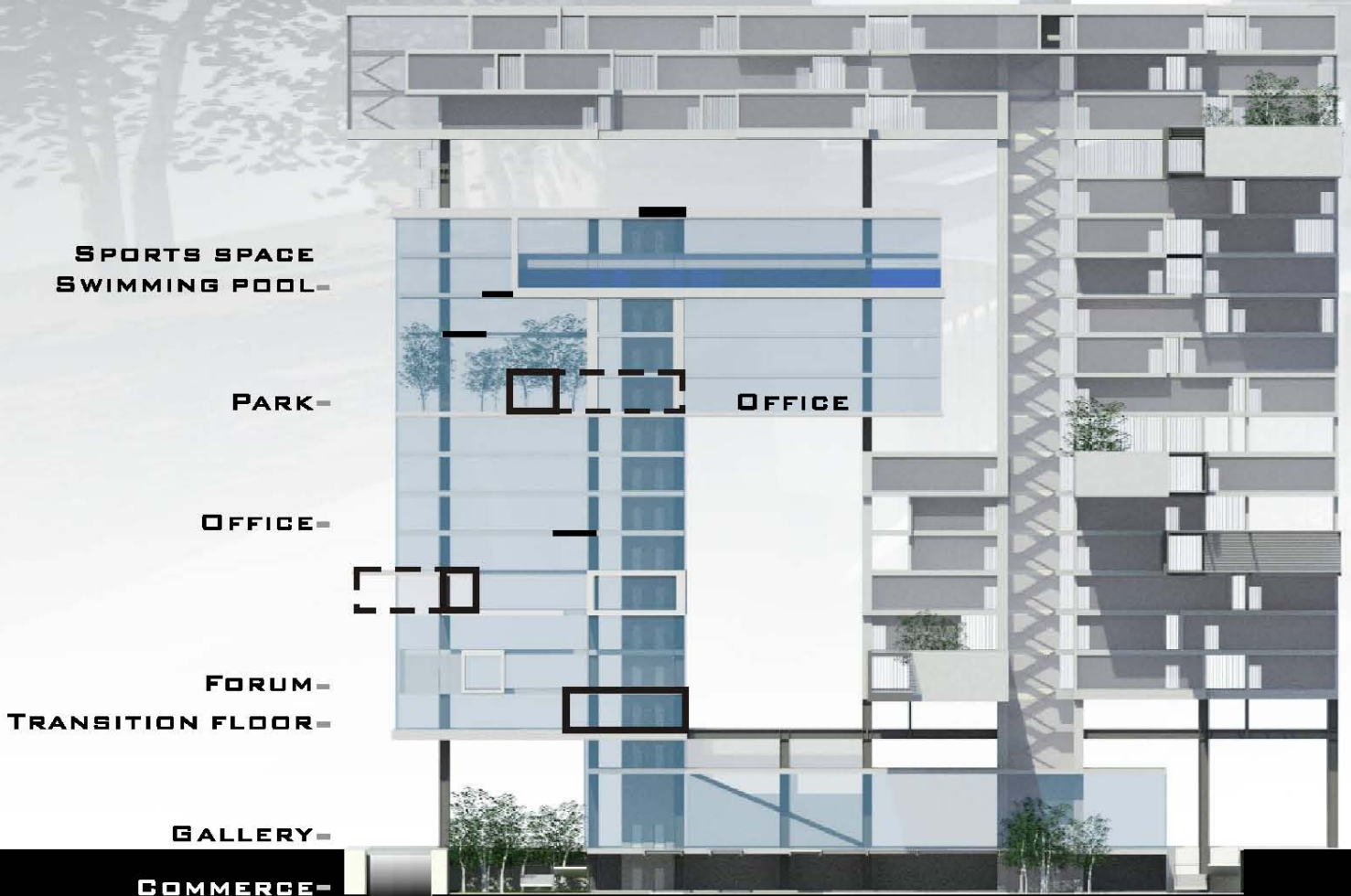

04-EMBEDDED RICHNESS
VERTICAL VILLAGE OF STREET-HOUSE



MEDIA SPACE
COMMUNITY CAGE-

OFFICE-

PARK-

LIBRARY-

COMMERCE-
PLAZA/
PLAYGROUND-

COMMERCE-

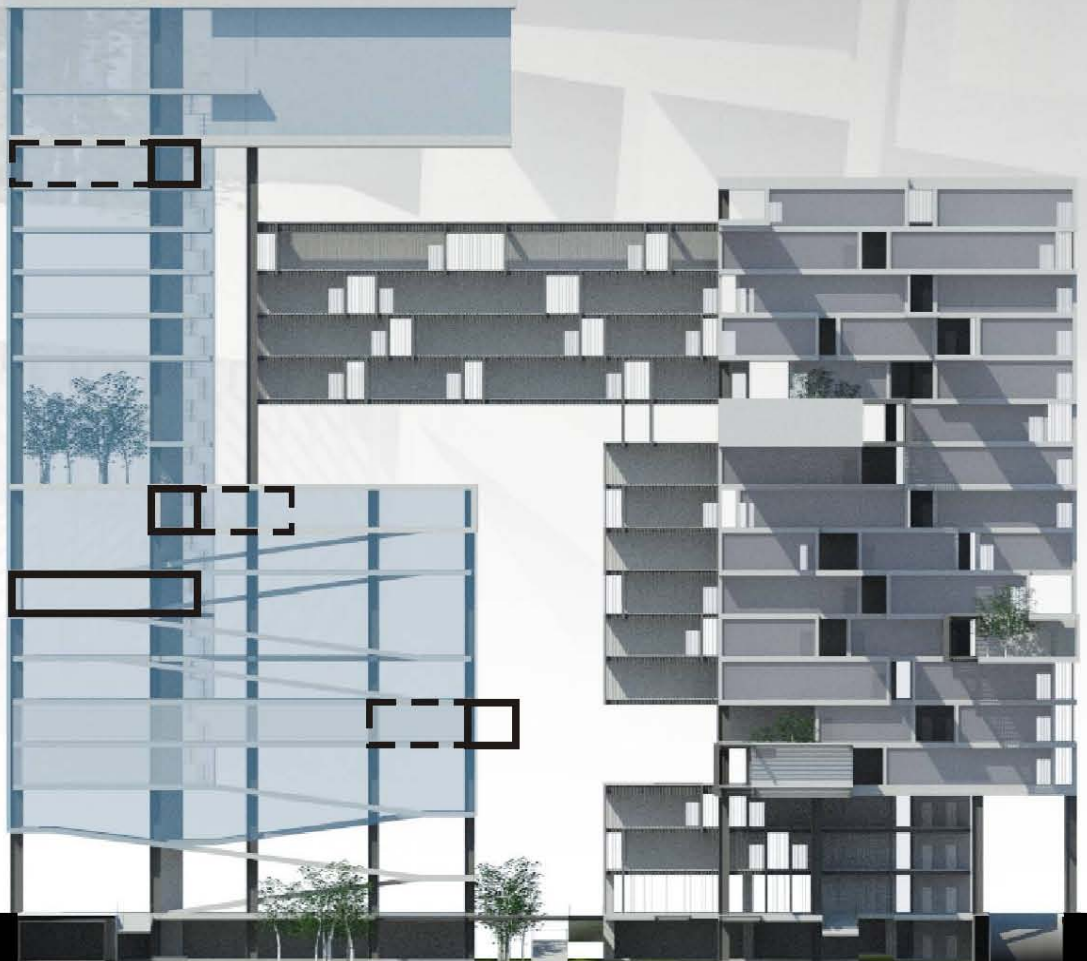



EMBEDDED RICHNESS

VERTICAL VILLAGE OF STREET-HOUSE



04-EMBEDDED RICHNESS
VERTICAL VILLAGE OF STREET-HOUSE

