

Angle measurement using total-internal-reflection heterodyne interferometry

Ming-Horng Chiu
Der-Chin Su

National Chiao Tung University
Institute of Electro-Optical Engineering
1001, Ta-Hsueh Road
Hsin-Chu, Taiwan
E-mail: t7503@cc.nctu.edu.tw

Abstract. A new optical method for angle measurement based on total-internal-reflection heterodyne interferometry is presented. In this method, heterodyne interferometry is applied to measure the phase difference between *s* and *p* polarization states at total internal reflection. This phase difference depends on the angle of incidence. Hence, small-angle measurement can be performed only by evaluating this phase difference. The validity of the method is demonstrated, and it has a measurement range of 10 deg. Its resolution depends on the angle of incidence; the best resolution is 8×10^{-5} deg. © 1997 Society of Photo-Optical Instrumentation Engineers. [S0091-3286(97)02406-9]

Subject terms: angle measurement; total-internal-reflection effect; heterodyne interferometry.

Paper 11106 received Oct. 4, 1996; revised manuscript received Jan. 31, 1997; accepted for publication Jan. 31, 1997.

1 Introduction

Optical measurement of small angles is conventionally performed with interferometers¹⁻⁵ and autocollimators.⁶⁻⁹ They have been widely used in alignment, machine-tool calibration, and many other applications. Although they are sensitive and accurate, their sizes are too large to be used in some space-limited areas. In order to solve these problems, Huang et al.^{10,11} proposed an optical method for small-angle measurement, namely, angle measurement based on the internal-reflection effect (AMIRE). In Huang's method, a beamsplitter is used to separate the incident beam into two beams with equal intensity, and two right-angle prisms are located on a rotary stage in an orthogonal alignment such that internal reflections occur in them. By measuring the reflectance difference between these two prisms, the small rotation angle can be estimated. This technique has some merits, such as a more compact size, simple setup, low cost, and high resolution, but there are still some disadvantages that might be alleviated:

1. Due to the intensity measurements, it can be performed only in the darkroom with a high stable light source.
2. The reflectance of a beamsplitter and the unnecessary reflectances at the entrance and exit surfaces of the prisms depend on the incident angle, so the measurands should be carefully estimated to enhance their accuracies.
3. The measurement range is too small (about 1.6 deg).

In this paper, in contrast to Huang's method, a new optical method for angle measurement based on total-internal-reflection heterodyne interferometry (TIRHI) is presented. In this method, the phase difference between *s* and *p* polarization states at total internal reflection is measured with heterodyne interferometry. Because the phase difference depends on the incident angle, small-angle measurement

can be performed by evaluating only the phase difference. This method has several advantages. First, the phase difference is independent of the intensity and can be extracted accurately despite surrounding light and instability of the light source. Second, it has high stability against air turbulence, due to its common-path configuration. Third, the optical setup is simple, compact, and easy to align. Furthermore, it has a high resolution and a larger measurement range.

2 The Principle of TIRHI

2.1 The Relation Between the Phase Difference and the Incident Angle at Total Internal Reflection

A ray of light in air is incident at θ_i on one side surface of a right-angle prism with refractive index n as shown in Fig. 1. The light ray is refracted into the prism and propagates toward the hypotenuse surface of the prism. At that surface there is a boundary between the prism and air. If the angle of incidence at the boundary is θ_1 , then we have

$$\theta_1 = 45^\circ + \sin^{-1} \left(\frac{\sin \theta_i}{n} \right). \quad (1)$$

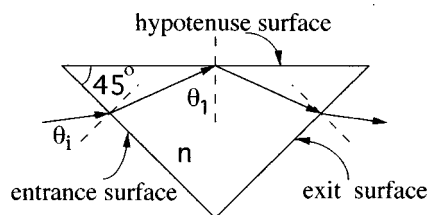

Fig. 1 The total internal reflection in a right-angle prism.

Here the signs of θ_1 and θ_i are defined to be positive if they are measured clockwise from a surface normal. Because θ_1 is larger than the critical angle, the light is totally reflected at the boundary. According to Fresnel's equation,¹² the phase difference between s and p polarization states is given as

$$\phi = 2 \tan^{-1} \left(\frac{(\sin^2 \theta_1 - 1/n^2)^{1/2}}{\tan \theta_1 \sin \theta_1} \right). \quad (2)$$

Substituting Eq. (1) into Eq. (2), then we have

$$\phi = 2 \tan^{-1} \left\{ \sin^2 \left[45 \text{ deg} + \sin^{-1} \left(\frac{\sin \theta_i}{n} \right) \right] - \frac{1}{n^2} \right\} / \left\{ \tan \left[45 \text{ deg} + \sin^{-1} \left(\frac{\sin \theta_i}{n} \right) \right] \sin \left[45 \text{ deg} + \sin^{-1} \left(\frac{\sin \theta_i}{n} \right) \right] \right\}. \quad (3)$$

For convenience, let

$$\sin^2 \left[45 \text{ deg} + \sin^{-1} \left(\frac{\sin \theta_i}{n} \right) \right] = x; \quad (4)$$

then Eq. (3) can be rewritten as

$$n^2 \sec^2(\phi/2) x^2 - (n^2 + 1)x + 1 = 0. \quad (5)$$

Then we obtain

$$x = \frac{n^2 + 1 \pm [(n^2 + 1)^2 - 4n^2 \sec^2(\phi/2)]^{1/2}}{2n^2 \sec^2(\phi/2)}. \quad (6)$$

To understand what the signs \pm in Eq. (6) represent, the later experimental condition $n = 1.51509$ is substituted into Eq. (3), and a plot of the phase difference ϕ against the incident angle θ_i is obtained and shown in Fig. 2. The plus sign and minus sign in Eq. (6) then correspond to the regions whose slopes are negative and positive in Fig. 2, respectively. In the former region, the absolute value of the

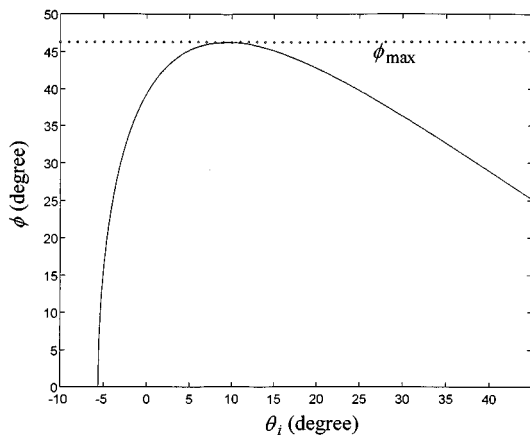

Fig. 2 The curve of ϕ versus θ_i .

slope is larger than in the latter, so the technique is more sensitive and has a higher resolution. Hence, we choose this region for our measurement range, that is, from the incident angle $\phi = 0$ (i.e., θ_1 equals the critical angle) to $\phi = \phi_{\max}$. Therefore, Eq. (6) can be rewritten as

$$x = \frac{n^2 + 1 - [(n^2 + 1)^2 - 4n^2 \sec^2(\phi/2)]^{1/2}}{2n^2 \sec^2(\phi/2)}. \quad (7)$$

Substituting Eq. (7) into Eq. (4), the incident angle to be measured can be obtained as follows:

$$\theta_i = \sin^{-1} [n \sin(\sin^{-1} \sqrt{x} - 45 \text{ deg})]. \quad (8)$$

2.2 Optical Setup for Measuring Phase Differences with Heterodyne Interferometry

The procedures for measuring the phase difference between s and p polarization states are the same as those for measuring the phase retardation of a wave plate. Chiu et al.¹³ proposed a heterodyne interferometric method for measuring the phase retardation of a wave plate, and good results were obtained. Here, Chiu's optical setup is modified by introducing a right-angle prism mounted on a rotary stage instead of the test wave plate, as shown in Fig. 3. Linearly polarized light passing through an electro-optic modulator (EO) is incident on a beamsplitter BS and is divided into reflected and transmitted light. The reflected light passes through an analyzer AN_r , then enters a photodetector D_r . The signal measured by D_r is the reference signal. The transmitted light enters the prism and is totally reflected there; then it propagates out of the prism. Finally, it passes through an analyzer AN_t and is detected by another photodetector D_t . The signal measured by D_t is the test signal. These two signals are sent to a phase meter, and their phase difference ϕ_t can be obtained. Then, we remove the test prism and let the transmitted light directly pass through AN_t and enter D_t . The phase meter obtains $-\phi_r$, where ϕ_r is the initial phase of the reference signal. Hence, the phase difference between s and p polarization due to total internal reflection is

$$\phi = \phi_t + \phi_r. \quad (9)$$

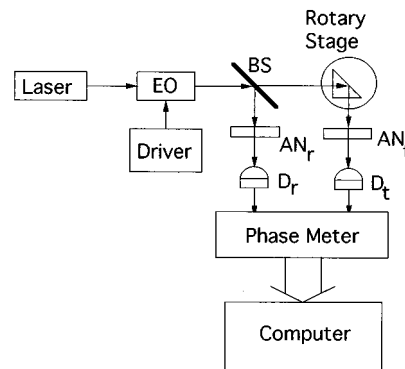

Fig. 3 Schematic diagram for this novel method for measuring small angles based on TIRHI. EO: electro-optic modulator; BS: beamsplitter; D: photodetector; AN: analyzer.

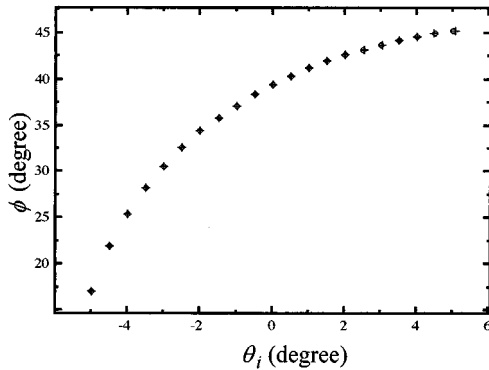

Fig. 4 The experimental curves of ϕ versus θ_i .

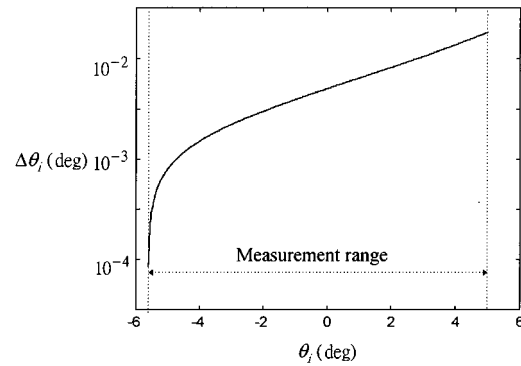

Fig. 5 The curve of $\Delta\theta_i$ versus θ_i .

Substituting the data on ϕ into Eqs. (7) and (8), the incident angle (or rotation angle) θ_i can be calculated. Here, the output of the phase meter is sent to a personal computer for calculation, so this method can be performed in real time and with high resolution.

3 Experiments and Results

A right-angle prism of BK7 glass with refractive index 1.51509 for 632.8-nm wavelength was used, and it is mounted on a high-precision rotary stage (PS- θ -90) with angular resolution 0.005 deg, manufactured by Japan Chuo Precision Industrial Co. Ltd. The incident angles θ_i of this prism, that is, the rotation angles of the rotary stage, were evaluated. Based on the measurement sensitivity and the above descriptions, the measurement range $-5.6 \leq \theta_i \leq 5$ deg was chosen. A He-Ne laser with a 632.8-nm wavelength and an electro-optic modulator (PC200/2, manufactured by England Electro-Optics Developments Ltd., with half-wave voltage 170 V) were used in this test. The frequency of the sawtooth signal applied to EO was 2 kHz. A phase meter with resolution 0.01 deg, built in this laboratory, was used. The experimental curve of ϕ versus θ_i for angle measurement is shown in Fig. 4. In the figure, the + spots represent the evaluated values of the rotation angles which are obtained by introducing the data of ϕ into Eqs. (7) and (8), and the circles represent the direct readouts of the division marks of the rotary stage. It is clear that they are in good correspondence.

4 Discussion

From Eq. (3), we can get

$$\Delta\theta_i \approx \frac{(n^2 \tan^2 \theta_i - 1)(n^2 \sin^2 \theta_i - 1)^{1/2}}{2n \sin \theta_i [2 - (n^2 - 1)\tan^2 \theta_i]} \times \frac{(n^2 - \sin^2 \theta_i)^{1/2}}{\cos \theta_i} \Delta\phi, \quad (10)$$

where $\Delta\theta_i$ and $\Delta\phi$ are the rotation angular error of the measurement of the rotary stage and angular error of the phase difference. It is obvious that, the angular resolution of the measurement is dependent on the incident angle of the prism (i.e., the rotation angle of the rotary stage) and the angular resolution of the phase meter. In our experi-

ment, the angular resolution of the phase meter is 0.01 deg. Consequently, the curve of $\Delta\theta_i$ versus θ_i can be obtained by substituting $n=1.51509$ and $\Delta\phi=0.01$ deg into Eq. (10), as shown in Fig. 5. Obviously, the rotation angular error becomes smaller as θ_i decreases. The best resolution can be obtained as the incident angle is in the neighborhood near the critical angle (i.e., $\theta_i \approx -5.6$ deg), and it is 8×10^{-5} deg.

5 Conclusion

A new optical method based on TIRHI for angle measurement is presented. The phase difference between s and p polarization states at the total internal reflection in a test prism is measured with the heterodyne interferometry. The rotation angle of the test prism can be evaluated after substituting the phase difference into Fresnel's equation. This method has some merits, such as a simple and compact optical setup, easy operation, high stability, high measurement accuracy, rapid measurement, and wider measurement range. Its feasibility is demonstrated.

Acknowledgment

This study was supported, in part, by the National Science Council, ROC, under contract No. NSC85-2215-E-009-005.

References

1. J. Rohlin, "An interferometer for precision angle measurements," *Appl. Opt.* **2**, 762-763 (1963).
2. D. Malacara and O. Harris, "Interferometric measurement of angles," *Appl. Opt.* **9**, 1630-1633 (1970).
3. G. D. Chapman, "Interferometric angular measurement," *Appl. Opt.* **13**, 1646-1651 (1974).
4. P. Shi and E. Stijns, "New optical methods for measuring small-angle rotations," *Appl. Opt.* **27**, 4342-4344 (1988).
5. P. Shi and E. Stijns, "Improving the linearity of the Michelson interferometric angular measurement by a parameter-compensation method," *Appl. Opt.* **32**, 44-51 (1993).
6. P. R. Yoder, Jr., E. R. Schlesinger, and J. L. Chickvary, "Active annular-beam laser autocollimator system," *Appl. Opt.* **14**, 1890-1895 (1975).
7. A. E. Ennos and M. S. Virdee, "High accuracy profile measurement of quasioconical mirror surface by laser autocollimation," *Precis. Eng.* **5**, 5-8 (1982).
8. F. J. Schuda, "High-precision, wide range, dual-axis, angle-monitoring system," *Rev. Sci. Instrum.* **54**, 1648-1652 (1983).
9. G. G. Luther and R. D. Deslattes, "Single-axis photoelectronic autocollimator," *Rev. Sci. Instrum.* **55**, 747-750 (1984).
10. P. S. Huang, S. Kiyono, and O. Kamada, "Angle measurement based

on the internal-reflection effect: a new method," *Appl. Opt.* **31**, 6047–6055 (1992).

11. P. S. Huang and J. Ni, "Angle measurement based on the internal-reflection effect and the use of right-angle prisms," *Appl. Opt.* **34**, 4976–4981 (1995).
12. M. Born and E. Wolf, *Principles of Optics*, 6th ed., pp. 48–50, Pergamon Press, Oxford (1980).
13. M. H. Chiu, C. D. Chen, and D. C. Su, "Method for measuring the fast axis and phase retardation of a wave plate," *J. Opt. Soc. Am. A* **13**, 1924–1929 (1996).

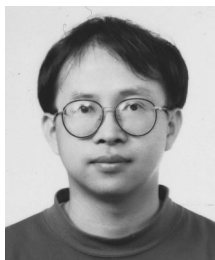

Ming-Horng Chiu received the MS degree from the Institute of Electro-Optical Engineering, National Chiao Tung University, Taiwan, in 1994. He is now working toward a PhD degree in optical metrology at the Institute of Electro-Optical Engineering of National Chiao Tung University. His research interests include optical metrology, optical information processing, and optical sensors.



Der-Chin Su received the BS degree in physics from National Taiwan Normal University in 1975, and the MS and PhD degrees in information processing from Tokyo Institute of Technology in 1983 and 1986, respectively. He joined the faculty of National Chiao Tung University in 1986, where he currently holds the position of professor at the Institute of Electro-Optical Engineering. His current research interests are in optical testing and holography.