

Chapter 4

New Pixel Circuits for Driving Organic Light Emitting Diodes Using Low-Temperature Polycrystalline Silicon Thin Film Transistors

4.1 Introduction

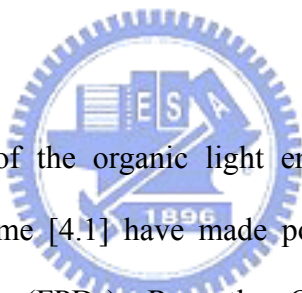

The rapid improvement of the organic light emitting diodes (OLEDs) brightness, luminous efficiency, and lifetime [4.1] have made possible their application to the high resolution flat panel displays (FPDs). Recently, OLED displays have been studied intensively owing to their various superior features over liquid crystal displays (LCDs) such as self-emissive characteristic, wide viewing angle, fast response time, simple device structure, compact form, and low cost [4.2]-[4.4]. Although some of the passive matrix OLED (PMOLEDs) have already proved their ability in the market, they have strict limitations on the panel size, resolution, and the image quality because of the requirements of high current and high voltage in each pixel and the susceptibility of cross talk [4.5]-[4.6]. On the contrary, active matrix OLEDs (AMOLEDs) which have the active devices integrated with OLED in each pixel are suitable for high information content displays in the future because they can eliminate these issues. For AMOLED, the driving transistor is used to control grey scale of panel by delivering the different current levels for OLED and each

OLED can be driven by amorphous silicon thin-film transistors (a-Si TFTs) [4.7], polycrystalline silicon thin-film transistors (poly-Si TFTs) [4.8] and organic thin-film transistors (OTFTs) [4.9]. A-Si TFTs can be fabricated on the large substrate with low cost and better uniformity [4.10]. OTFTs can be made on the flexible plastic substrate because of low process temperature. However, the driving ability and stability of a-Si TFTs and OTFTs are issues and need to be solved. Low-temperature polycrystalline silicon thin-film transistors (LTPS-TFTs) are mostly used as pixel driving devices of displays for high-end applications due to their higher field-effect mobility and stability leading to the possibility for the driver to be integrated on the panel [4.11]. Since OLEDs are current driven devices, LTPS TFTs must supply a steady current to get the uniform brightness across the panel. Nevertheless, the simple circuit design with two transistors and one capacitor (2T1C) suffers from pixel to pixel luminance non-uniformity due to the electrical characteristic variations of the transistors such as threshold voltage variation, mobility variation, and subthreshold swing variation. This is mainly caused by the narrow process window of super lateral growth regime (SLG) of excimer laser crystallization (ELC) which results in the nearly uncontrollable grain size and the grain boundaries of poly-Si during the laser crystallization process. In order to realize AMOLED with poly-Si TFTs, each pixel design should compose compensation circuits against the characteristic variation of the transistors.

Recently, several pixel circuits with compensation scheme have been proposed [4.12]-[4.19]. These can be classified into digital driving method [4.12]-[4.13], current driving method [4.14]-[4.16], and voltage driving method [4.17]-[4.19]. Digital driving methods are good in terms of uniformity because the driving transistor operates in either on or off states, so the threshold voltage and mobility variations has no influence on the OLED luminance. However, they require fast addressing time and frame memories in the sub-frame data generator, which would increase the cost and power consumption of the driver system. Current driving method can compensate the electrical variation of the

transistors and solve the voltage drop problem at power supply line by self-compensation, but the settling time is unrealistically long and the control of accurate current level is rather difficult at low data input current due to high parasitic capacitance of data lines. This will become a critical problem in the high resolution and large panel size displays. Even though voltage driving method can only compensate threshold voltage variation, it is not a critical problem since the adverse influence of current variation upon mobility is less significant than that upon threshold voltage [4.20]. Moreover, voltage programming pixel circuit is more attractive because poly-Si TFT data drivers which are compatible with LCD drivers can be integrated on display panel to decrease the module cost and increase the panel reliability. One of the voltage programming methods which was reported by Dawson can solve the threshold voltage variation effectively, but it employed two additional control signal lines and two capacitors which makes peripheral drivers and circuit structure rather complex [4.21].

In this chapter, two new pixel circuits for producing better brightness uniformity are proposed. In order to overcome the problem caused by spatially non-uniform device characteristics in TFTs across the glass substrate, special voltage programming pixel circuits which consist of five LTPS TFTs and one capacitor with simple circuit operation are designed. The proposed circuits compensate the threshold voltage variation of LTPS TFTs by itself and solve the mismatch problems between the driving transistor and the compensating transistor in the same pixel. At first, conventional pixel circuit with two transistors and one capacitor is introduced. Following that, the concept for compensating the threshold voltage variation in each pixel by diode connection is presented. The detail information and operation principle of the two proposed circuit designs and driving schemes are shown and discussed. Various simulation results of the proposed pixel circuits based on the extracted device parameters from the experimental data are shown and compared with the conventional one. These simulation results show the proposed circuit designs can

successfully eliminate the threshold voltage variation of the poly-Si TFTs. Performance of these two proposed pixel circuits and other pixel design are also compared and analyzed.

4.2 Conventional Pixel Design

The difference between AMLCD and AMOLED is that one additional transistor is needed for AMOLED to function as a current source controlled by the data voltage as shown in Fig. 3.2. The data voltage is directly applied to the gate of driving transistor, T2. Assuming that TFT2 is operated in the saturation mode, the drain current for OLED would equal to $I_d = \frac{1}{2}k_2(V_{gs_T2} - V_{th_T2})^2$, where $k_2 = \mu C_{ox} \frac{W_2}{L_2}$. However, due to the nature of the fabrication process, device parameters such as threshold voltage, mobility, and subthreshold swing between two transistors are not assumed to be the same. Fig. 4.1 shows the cumulative distributions of the device parameters from 30 n-channel LTPS TFTs fabricated on the same glass substrate. The threshold voltage was extracted from the gate voltage (V_{gs}) at a normalized drain current of $I_d = (W/L) \times 10^{-8}$ A at $V_{ds} = 0.1$ V. The field-effect mobility was calculated from the maximum transconductance in the linear region of I_d - V_g characteristics at $V_{ds} = 0.1$ V and the minimum subthreshold swing was measured at $I_d = (W/L) \times 10^{-8}$ A at $V_{ds} = 0.1$ V. It can be seen obviously that there is a large variation in the electrical characteristics between the transistors over the substrate glass. When OLED are driven by these driving TFTs, a large steady state output current error and non-uniform brightness image will be produced in the panel. Therefore, some improvement of conventional circuit design is necessary to make sure that the OLED is driven by a specified current that is insensitive to the device variation in TFTs.

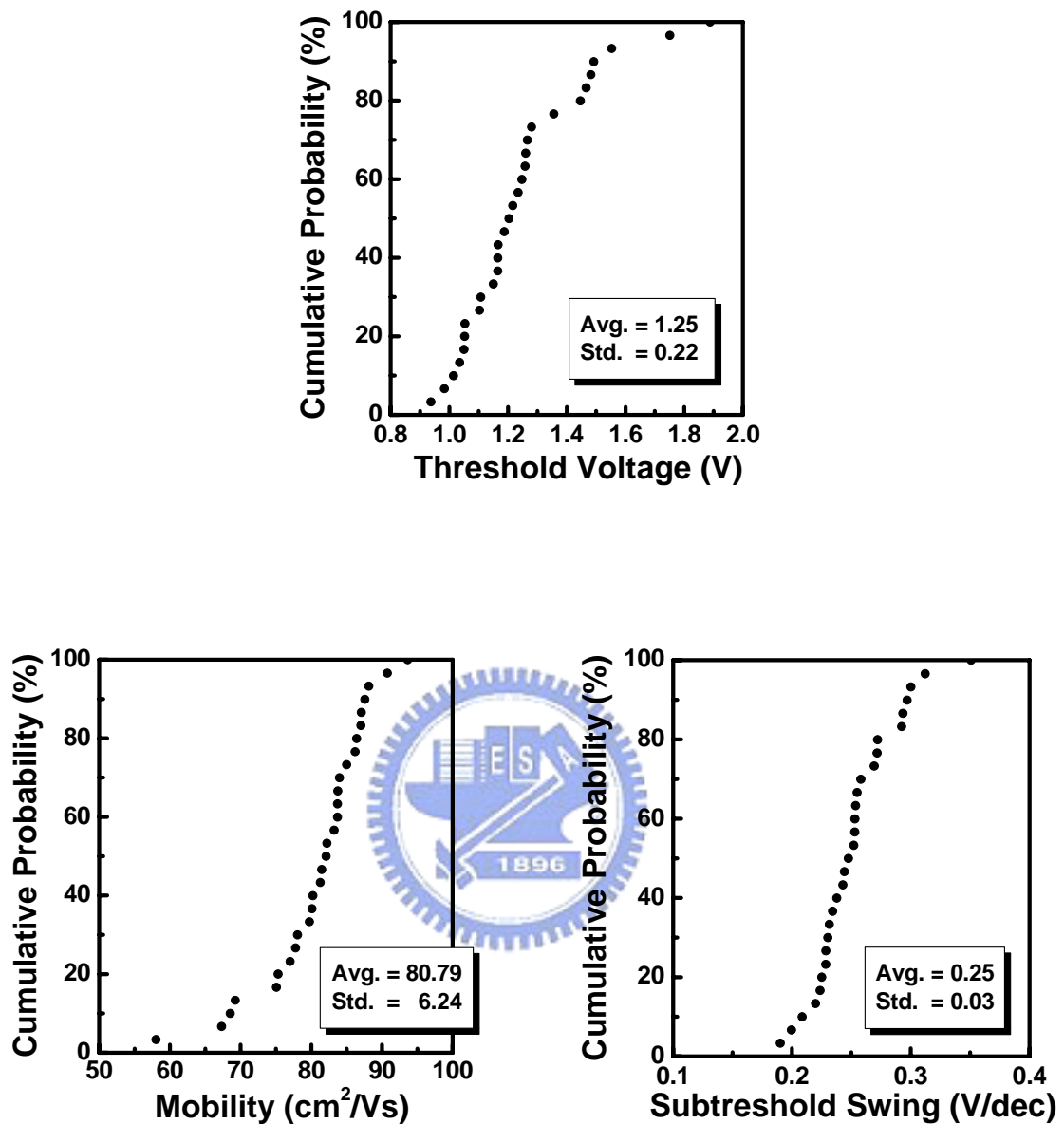

Fig. 4.1. Cumulative distributions of the device parameters from 30 n-channel LTPS TFTS fabricated on the same glass substrate.

4.3 Compensation Method Using Diode Connection

Concept

In the voltage driven pixel circuit, the driving transistor is diode-connected during

programming period. As shown in Fig. 4.2, the design of a pixel which compensates for the threshold voltage variation needs additional transistors as switches to make driving transistor diode-connected and pass data voltage during programming. In the n channel TFT circuit, the gate terminal of the driving transistor is connected to the anode of the resulting diode, while in the p channel TFT circuit, the gate terminal of the driving transistor is connected to the cathode of the resulting diode. At this time, the storage capacitor (C_s) is connected between the gate terminal of driving transistor and a DC source which results in the serial connection of storage capacitor and diode between the data voltage and a DC source. As a result, for the n channel TFT circuit, the gate terminal of driving transistor would equal to $V_{data} + V_{th}$ after programming, likewise for the p channel TFT circuit, the gate terminal of driving transistor would become $V_{data} - |V_{th}|$ after programming.

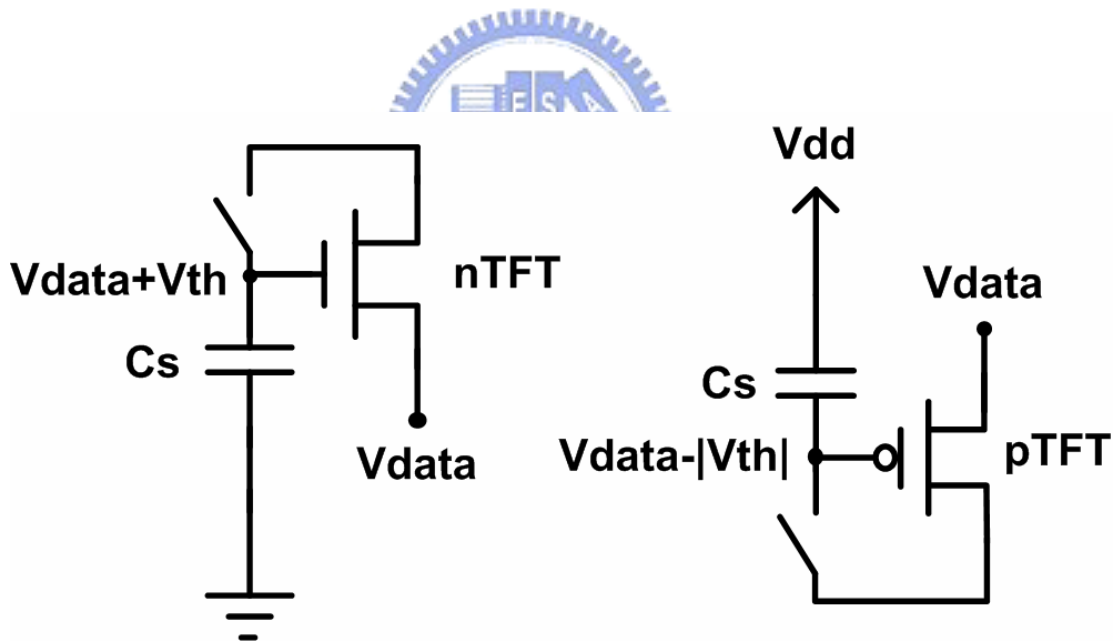

Fig. 4.2. Examples of compensation by diode connection in the n channel TFT circuit and p channel TFT circuit.

4.4 Proposed Pixel Design

Fig. 4.3 shows the proposed pixel design and the timing diagram. N channel TFTs are used in order to eliminate the problem of voltage drop of supply line voltage (IR drop) due to the intrinsic resistance of the V_{DD} line. The circuit structure consists of five TFTs, one capacitor and one OLED device. TFT1, TFT3, TFT4, and TFT5 are switching TFTs. TFT2 is a driving TFT, which supplies drain current for OLED during emission period. C_s is a storage capacitor which stores the needed gate voltage for TFT2. V_{data} is a data signal voltage line and V_{dd} is a common voltage source line. Besides the scan line (V_{sel}), only one additional control (V_{ctrl}) line is used. The operation scheme and compensation principle of the pixel design are described as follows.

1. Reset period – During the first period, reset action is performed. V_{sel} and V_{ctrl} signals are high voltages, all TFTs in the pixel are on state. The previous stored voltage in the C_s would be charge up to a specific value which is related to the following data signal in order to form a diode connection of TFT2 during the next period.

2. Data input period – V_{ctrl} is low, turning off TFT4 and TFT5 for storing the threshold voltage of driving transistor (TFT2). At this time, the gate terminal of TFT2 is connected with the drain terminal by TFT3. Because TFT2 acts as a diode, V_{gs} is V_{th_T2} and stored voltage across the capacitor is $V_{data} + V_{th_T2}$.

3. Emission period – After pixel scanning time and sampling the signal voltage stage, V_{sel} is low and V_{ctrl} is high. During this period, driving TFT (TFT2) starts to drive OLED. Because stored voltage in C_s would maintain until the next reset period, the drain current of TFT2 in the saturation region for OLED becomes as follows.

$$I_{OLED} = \frac{1}{2}k_2(V_{gs_T2} - V_{th_T2})^2 = \frac{1}{2}k_2(V_{data} + V_{th_T2} - V_{th_T2})^2 = \frac{1}{2}k_2V_{data}^2, \text{ where}$$

$$k_2 = \mu C_{ox} \frac{W_2}{L_2}$$

It is observed that the OLED current is independent of the threshold voltage of TFT2. Therefore, pixel to pixel threshold voltage variation on the glass substrate does not affect the

output current, uniform brightness image can be obtained.

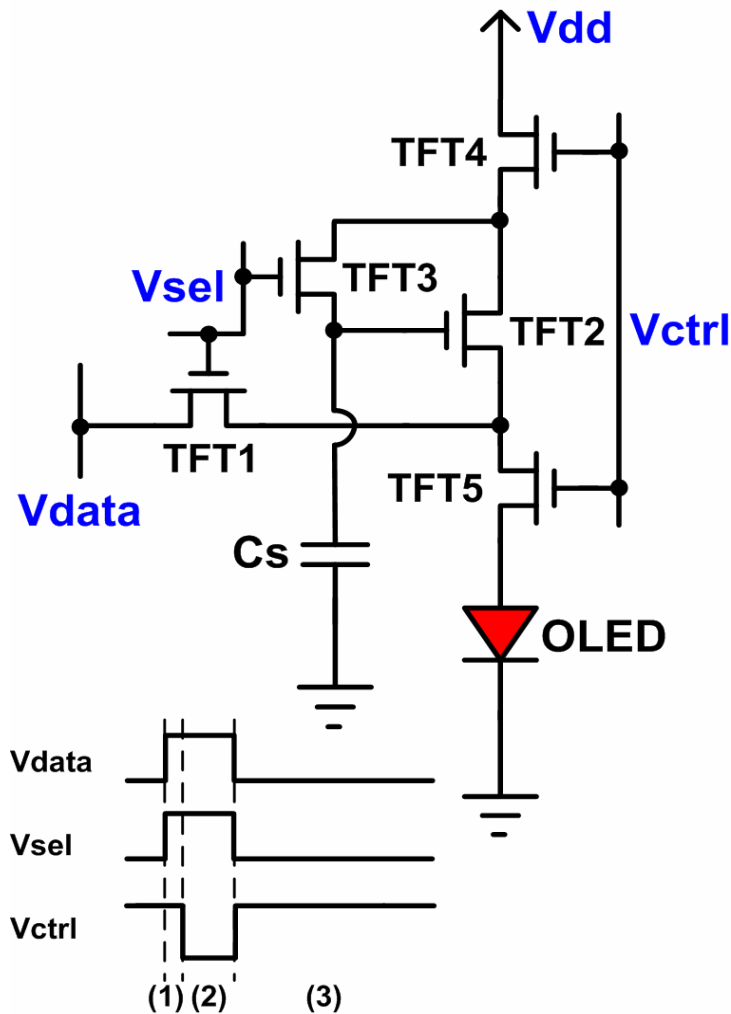

Fig. 4.3. Proposed pixel design and the timing diagram of signal lines.

4.5 Simulation Results and Discussion

In order to verify the pixel design performance, circuit simulation using HSPICE was performed. In this work, the aperture ratio is about 40 % for a 4-inch QVGA specification. Fig. 4.4 shows the measured and simulated OLED current versus bias voltage characteristics. Attributing that OLEDs are current driving devices, gray scale of the display can be achieved by modulating the current level pixel to pixel. In this thesis, a 4-inch QVGA

specification is assumed. Device characteristics of n-type LTPS TFTs using HP4156C measurement system were measured for SPICE modeling. Simulation parameters were extracted from BSIMPro v2 and the model used in simulation was RPI poly-silicon TFT model (LEVEL 62). Figure 4.5 shows the measured and simulated transfer characteristic of n-channel TFT which shows good fitting results. These modeling parameters were employed for SPICE simulation. The device parameters such as threshold voltage and mobility are 1.55V and 52.02 cm²/V-s. Fig. 4.6 shows the transient response for the conventional 2T1C pixel circuit. In this case, the threshold voltage deviation of driving TFTs is assumed to be ± 0.33 volt. It is observed that the anode of OLED is dependent on the threshold voltage deviation which is a key factor in brightness and the variation of anode voltage is about 0.26V. Due to the spatial variation of threshold voltage in the driving transistor TFT2 caused by process variation, non-uniform image quality over the display will become a critical issue.

Compared with conventional 2T1C pixel circuit, the transient response of the proposed pixel circuit shows much consistence of driving current against the threshold voltage variation as shown in Fig. 4.7. It is demonstrated that the anodes of OLED devices are insensitive to different threshold voltages. Fig. 4.8 shows the gate voltage in the capacitor as the threshold voltages of TFTs are varied. In the first stage, the gate voltage of TFT2 pre-charges to a high voltage. The $V_{data} + V_{th_T2}$ are stored in the capacitor according to the different threshold voltages during the next data input period. After scanning time, V_{gs} is almost the same value as the stored voltage in C_s and the emission stage begins. The difference of the stored voltage in the capacitor almost equals to the difference of threshold voltage in driving transistor. Because the modulated data voltage is stored in the capacitor, the proposed circuit can successfully compensate for the threshold voltage variation of TFTs.

To study the effect of the device variation on the proposed circuit design, Monte Carlo

simulation with an assumption of normal distribution was executed. The mean value and the deviation of the threshold voltage and mobility are 1.55V, $\pm 1V$, 52.02 $\text{cm}^2/\text{V}\cdot\text{s}$, and $\pm 20 \text{ cm}^2/\text{V}\cdot\text{s}$, respectively. Fig. 4.9 (a) and Fig. 4.9 (b) show the simulation results of the conventional pixel design and the proposed pixel design with 30 times Monte Carlo simulation. It is observed that the smaller current variation can be achieved in the proposed circuit. The variation of emission current of the conventional design is $0.029 \mu\text{A}$, while that of the proposed circuit design is only $0.0023 \mu\text{A}$. The threshold voltage compensation for LTPS TFT can be obtained in the proposed circuit design.

Fig. 4.10 shows the simulation results of non-uniformity compared with conventional 2T1C pixel circuit when the threshold voltage deviation of driving TFT is ± 0.33 volt. Non-uniformity is defined as the difference between the maximum output current and the minimum output current divided by the average output current. It can be seen that the non-uniformity can be reduced effectively from 50% of the conventional pixel to less than 5% of the proposed AMOLED pixel design under the same threshold voltage variation of TFT devices. The simulation parameters for the proposed circuit design are summarized in Table 4.1.

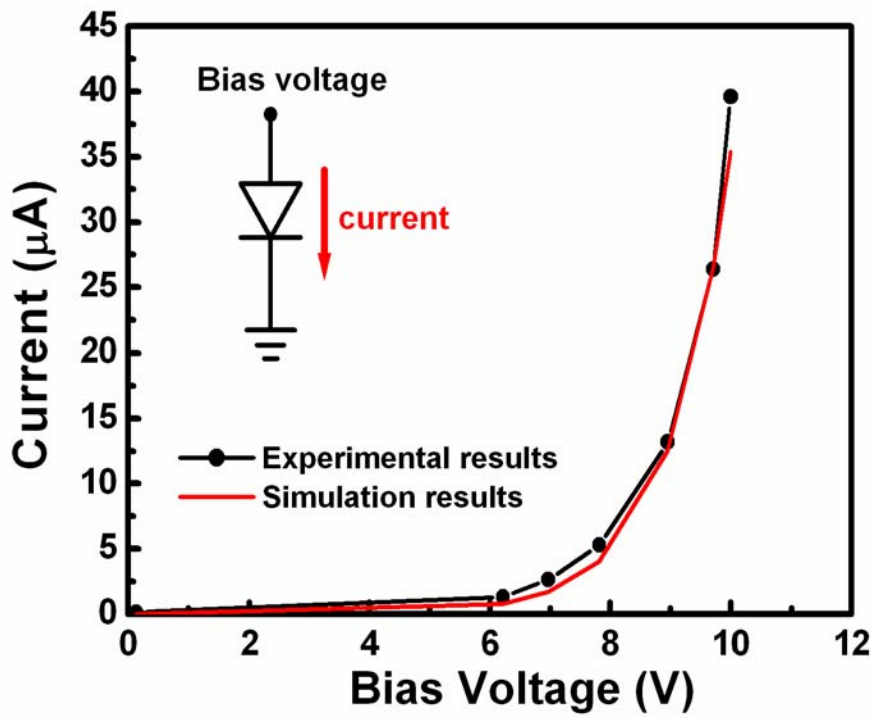

Fig. 4.4 The measured and simulated OLED current versus bias voltage characteristics.

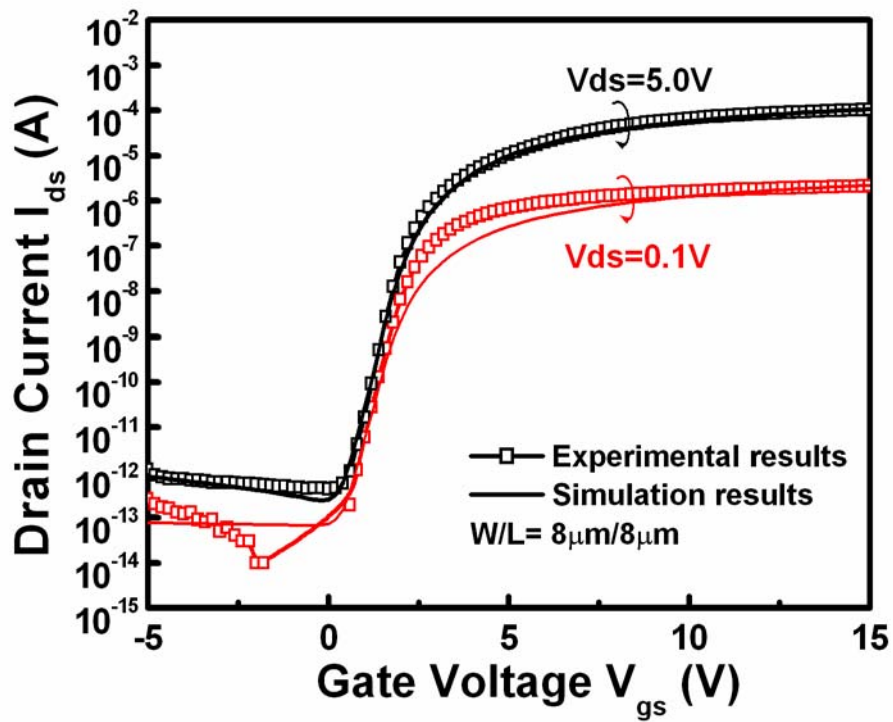

Fig. 4.5. The measured and simulated transfer characteristics of n channel TFTs.

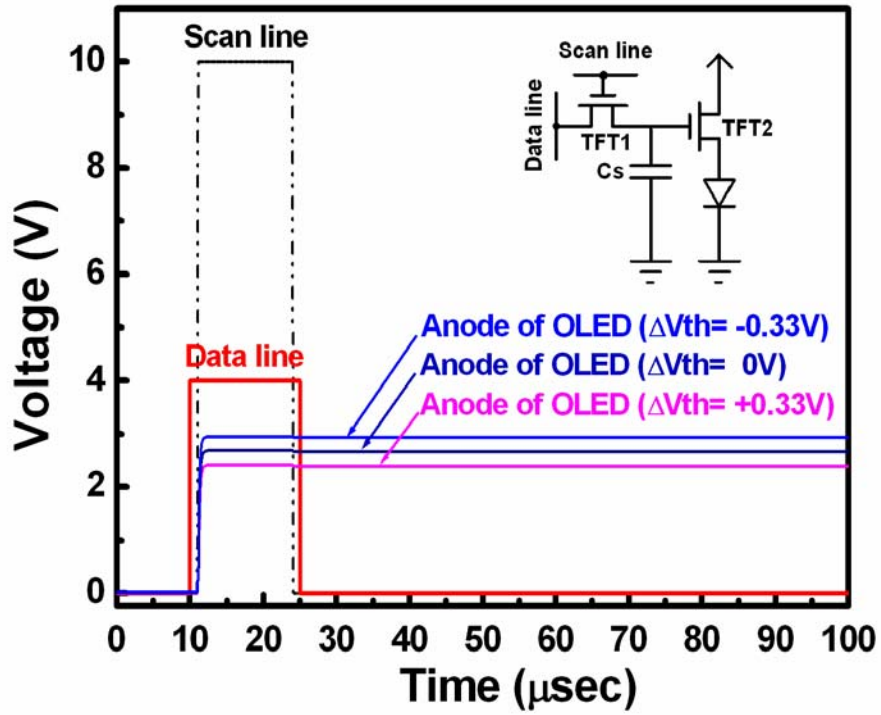

Fig. 4.6. Transient response of the conventional 2T1C pixel circuit.

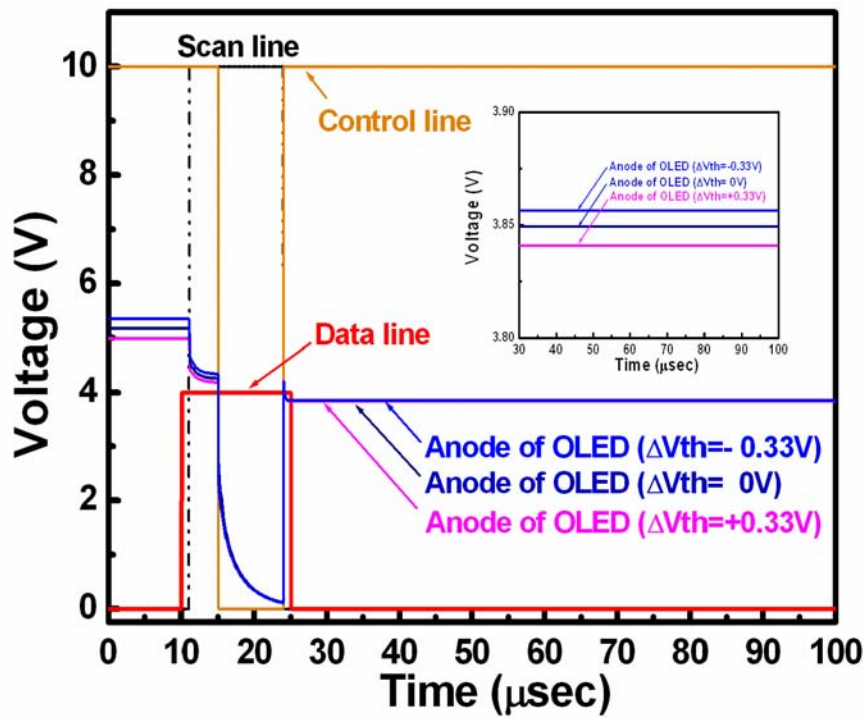

Fig. 4.7. Transient response of the proposed pixel circuit.

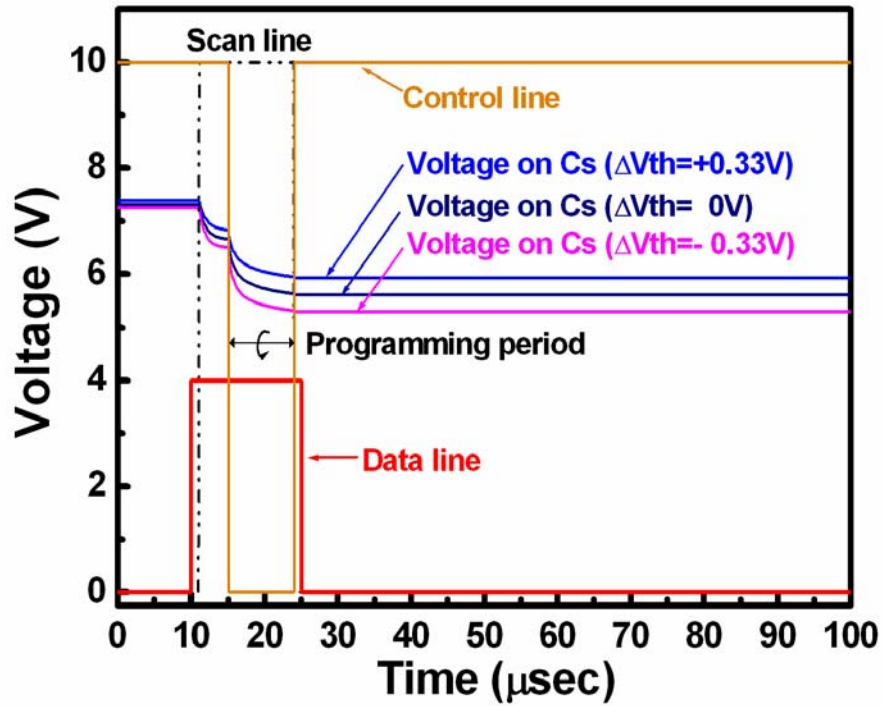

Fig. 4.8 The gate voltage in the capacitor as the threshold voltages of TFTs are varied.

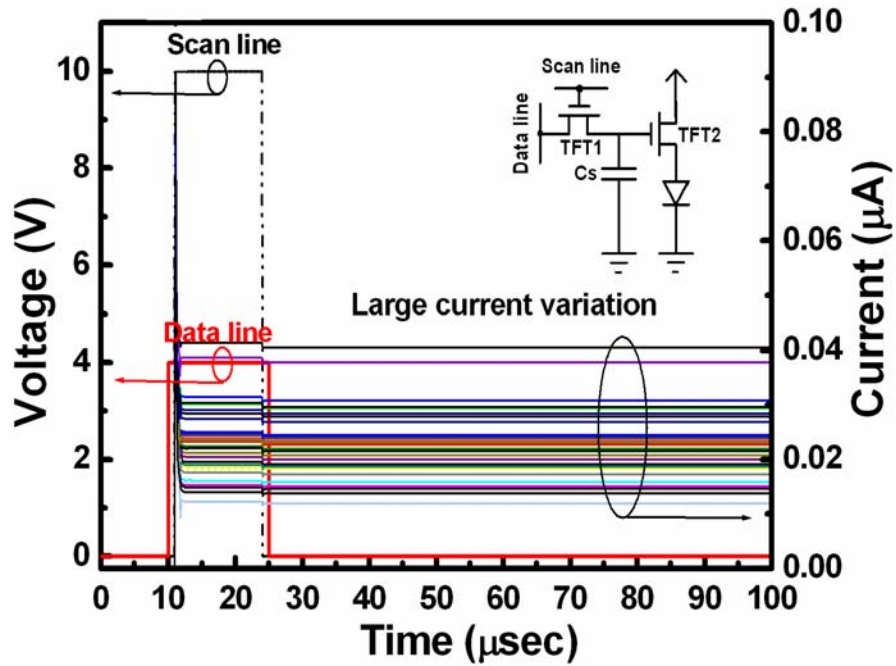

Fig. 4.9(a)

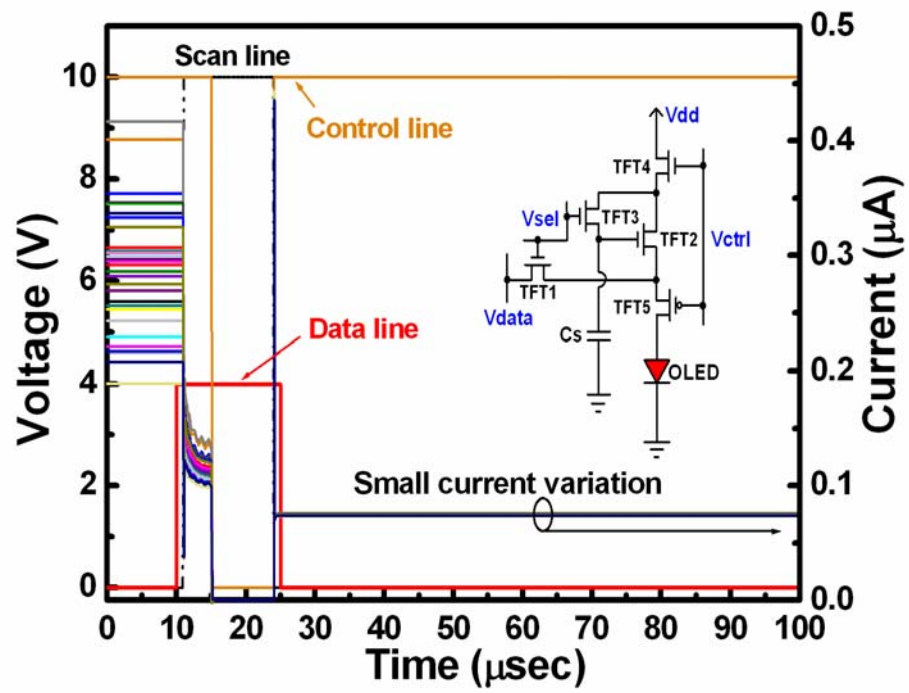
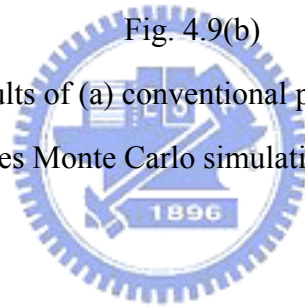

Fig. 4.9(b)

Fig. 4.9. The simulation results of (a) conventional pixel design and (b) proposed pixel design with 30 times Monte Carlo simulation.



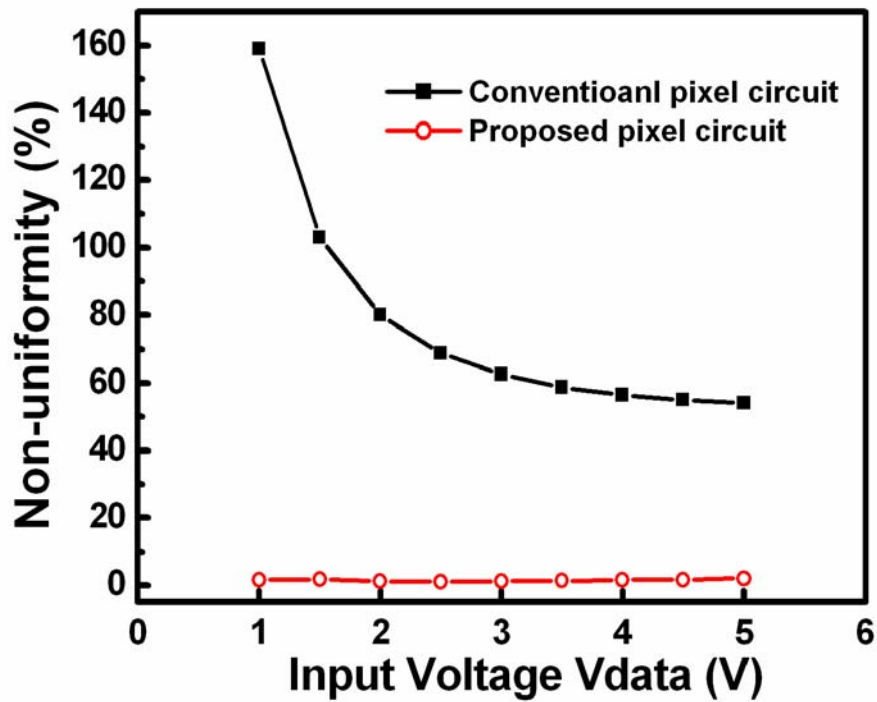
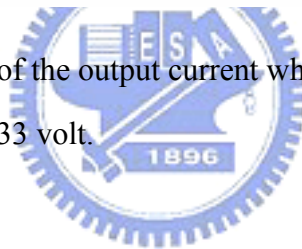

Fig. 4.10. The non-uniformity of the output current when the threshold voltage deviation of driving TFT is ± 0.33 volt.



Devices			
W/L (T1,T3,T4,T5)		W/L (T2)	C_s
6 μ m/6 μ m		80 μ m/6 μ m	1pF
Signal lines		Time	
V_{dd}	V_{ctrl}, V_{sel}	T(1)	T(2)
10V	0V~10V	5 μ s	10 μ s

Table 4.1. Circuit simulation parameters.

4.6 Experimental Results of the Proposed Pixel Design and Discussion

The testing pixel circuits were fabricated by the following sequence of processes. Fig. 4.11 shows the optical micrograph view of proposed pixel circuit. First, a buffer oxide and a 500Å-thick a-Si thin film were deposited on glass substrate. Then, the amorphous Si thin film was crystallized by XeCl excimer laser annealing at room temperature in the N₂ gas ambient. After defining the active layer, a 1000Å-thick gate oxide was deposited by plasma-enhanced chemical vapor deposition (PECVD) and a 4000Å-thick Cr film was then deposited for gate electrode. The Cr thin film and gate oxide were etched in order to form gate electrodes. Ion implantation was then performed to form source and drain regions. Next, a 4000Å-thick SiNx was deposited by PECVD as interlayer. The TFT testing pixel circuits were formed after contact-hole formation and 4000Å-thick Cr metallization.

Fig 4.12 shows the measurement system for testing pixel circuits, it includes Agilent 4156C, HP 41501A pulse generator, Agilent 54622D mixed signal oscilloscope, and Keithley 617 programmable electrometer. The main system is HP 4156C including four probes. HP 41501A provides two voltage pulse and Keithley 617 programmable electrometer supplies one DC signal voltage through an additional probe. Through the coaxial cable and BNC connection, the output signal voltage can be figured in Agilent 54622D mixed signal oscilloscope. One of the most important things is that the ground terminals of all instruments must connect in all.

After system is ready for measurement, the output signal voltages of proposed pixel design and conventional pixel design were measured. Ten testing pixel circuits have been measured. The measured results of conventional pixel circuits and proposed pixel circuits with different data voltages are shown and compared in Fig. 4.13. It is obvious that

proposed pixel circuit posses higher output voltage and better uniformity after calibrating out the threshold voltage variation. Fig. 4.14 shows the simulation and measured results of non-uniformity compared with conventional 2T1C pixel circuit. The voltage non-uniformity is defined as the difference between the maximum output voltage (OLED anode voltage) and the minimum output voltage divided by the average output voltage. By experimental results, the non-uniformity can be suppressed to less than 10% in the proposed circuit. It is verified that the proposed pixel design has high immunity to the variation of poly-Si TFT characteristics.

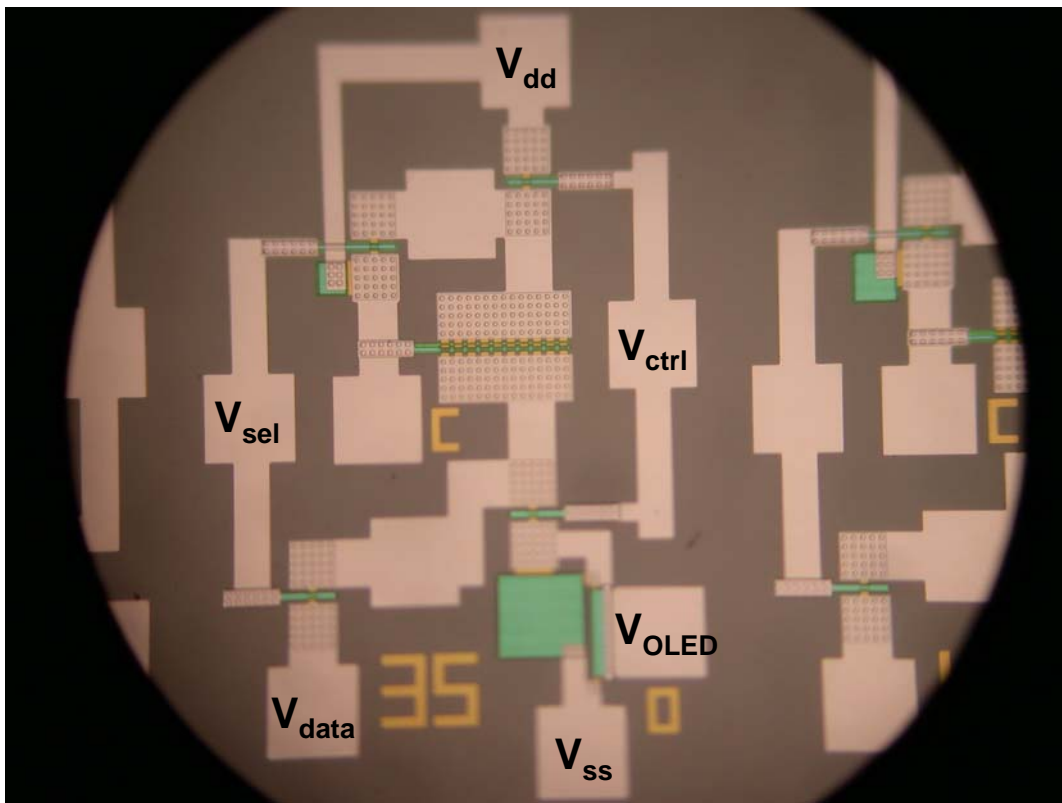

Fig. 4.11. Optical micrograph of proposed pixel circuit.

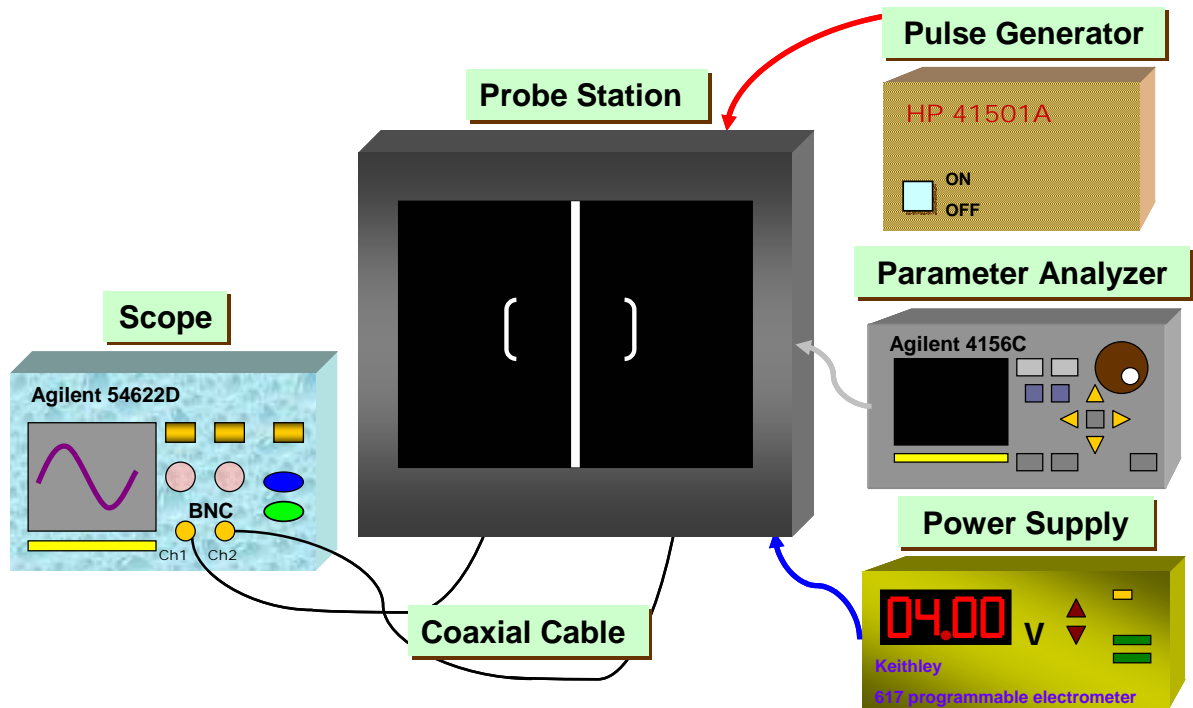

Fig. 4.12. Measurement system for testing pixels.

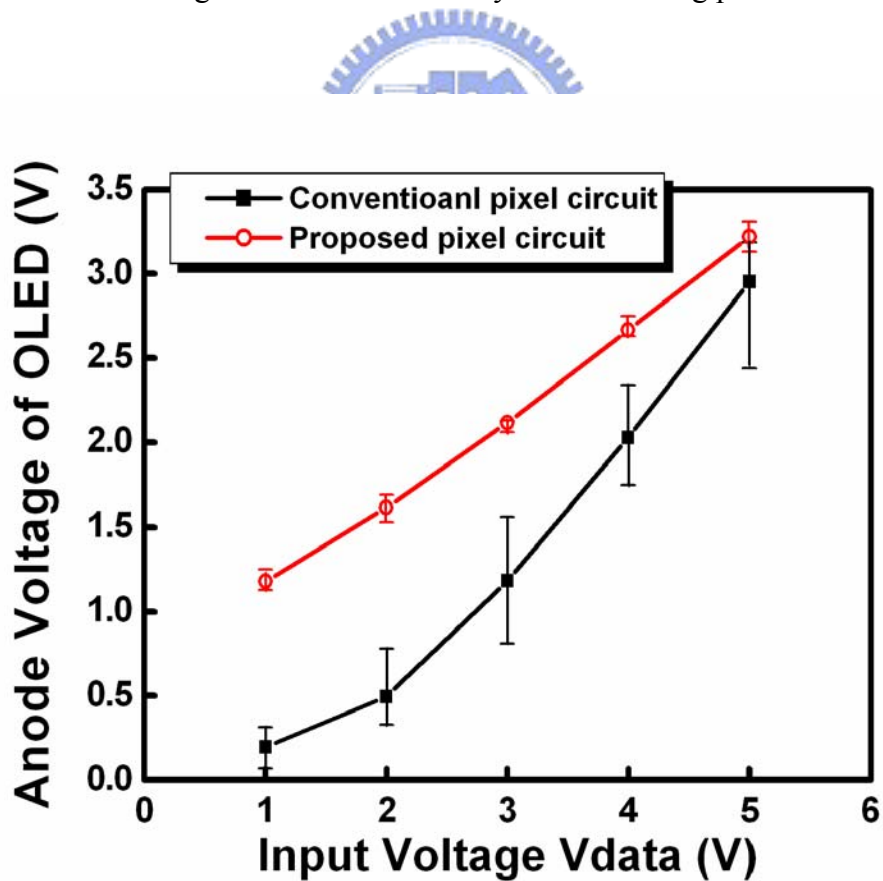

Fig. 4.13. The measured results of conventional pixel circuits and proposed pixel circuits with different data voltages.

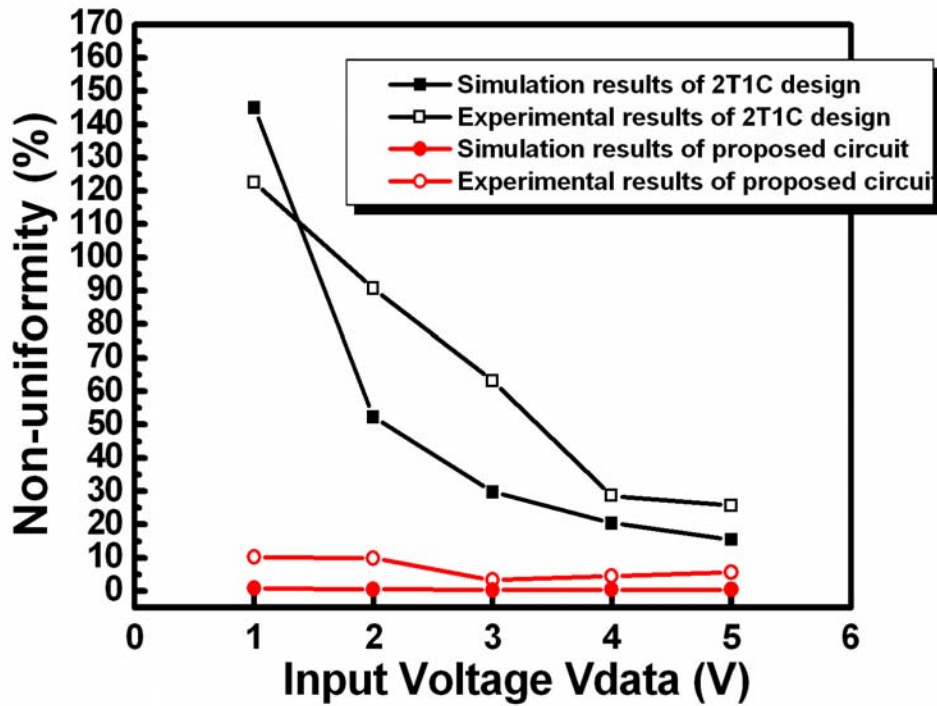
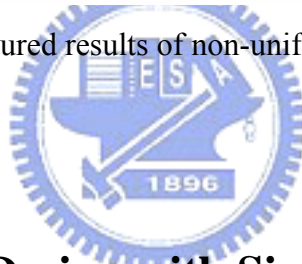

Fig. 4.14. Simulated and measured results of non-uniformity compared with conventional 2T1C pixel circuit.



4.7 Modified Pixel Design with Simulation Results and Discussion

4.7.1 Modified pixel design

Fig. 4.15 shows the modified pixel circuit and the timing diagram of control signals. The circuit design consists of four switching TFTs (TFT1, TFT3, TFT4, TFT5) and one driving TFT (TFT2), one capacitor and one OLED device. Except that TFT5 is a p-channel TFT, other transistors are n-channel TFTs and only one additional signal line entitled (V_{ctrl}) line is used. V_{data} is a data signal voltage line and V_{dd} is a constant voltage source line. The operation scheme and compensation principle of the pixel design are described as follows.

1. Initialization period: During first period, V_{sel} and V_{ctrl} signals are set to high voltage, TFT1, TFT3 and TFT4 are turned on consequently. The previous stored voltage in the Cs is reset to a specific value related to the following data signal. In the meanwhile, TFT5 blocks the emission current flow through OLED.

2. Data input period: Switching transistors TFT1 and TFT3 are active, TFT4 and TFT5 are turned off. Data voltage is programmed to the gate terminal of TFT2 through diode connected TFT2 by TFT3. At this time, $V_g = V_{data} + V_{th_T2}$ and would be stored in Cs for the whole period because TFT2 is diode connected.

3. Emission period: Then TFT4 and TFT5 are turned on during this period. OLED begins to emit corresponding light. The drain current of TFT2 in the saturation region, which flows through TFT4, TFT2, and TFT5 becomes

$$I_{OLED} = \frac{1}{2} k_2 (V_{gs_T2} - V_{th_T2})^2 = \frac{1}{2} k_2 (V_{data} + V_{th_T2} - V_{th_T2})^2 = \frac{1}{2} k_2 V_{data}^2, \text{ where}$$

$$k_2 = \mu C_{ox} \frac{W_2}{L_2}$$

Because the gate voltage of TFT2 for output current already contains the information of its threshold voltage, output OLED current (I_{OLED}) is independent of the threshold voltage and only affected by the input data voltage.

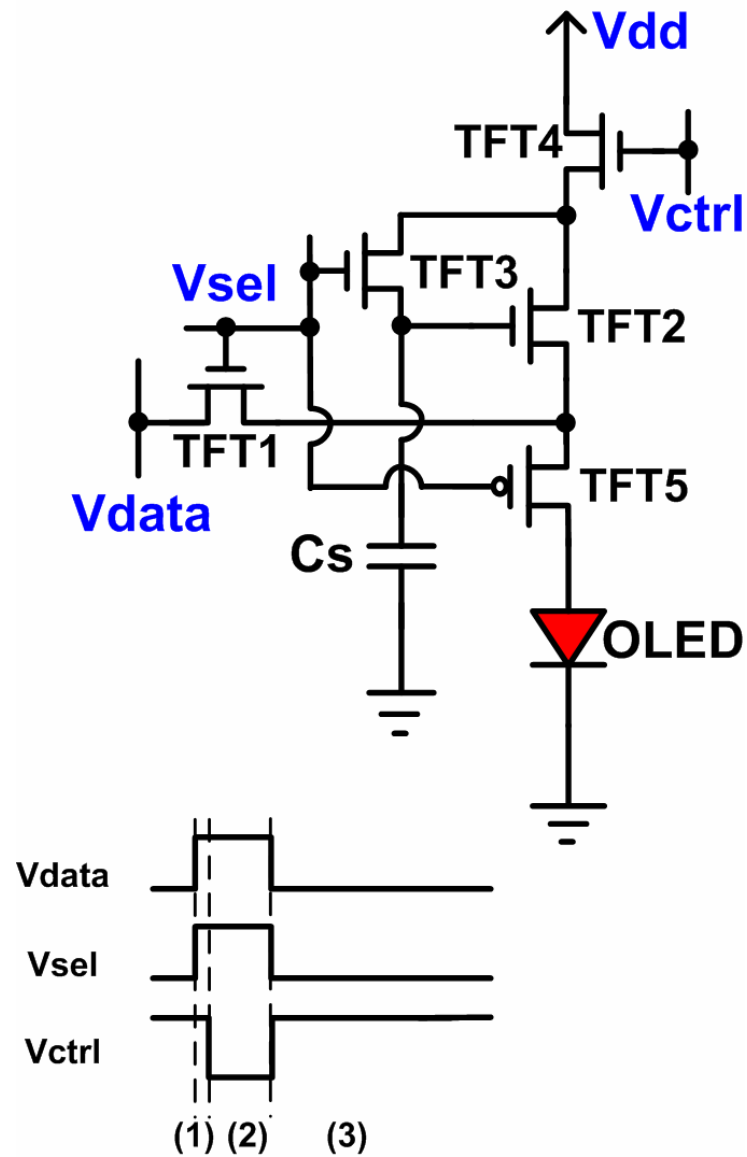

Fig. 4.15. Modified pixel circuit and the timing diagram of control signals.

4.7.2 Simulation Results and Discussion

To verify the modified pixel design, HSPICE simulation was executed and discussed. Electrical characteristics of p channel TFT were measured from HP4156C measurement system. The model parameters used in the simulation were extracted by BSIMPro v2 based on RPI polysilicon TFT model (LEVEL 62). The simulation parameters for the modified

circuit design are the same as those in Table 4.1.

Fig. 4.16 shows the transfer characteristics of p-type TFT which was well-matched to p-type TFT model and the transfer characteristics of n-channel TFT was the same as Fig. 4.5.

Fig. 4.17 shows the transient response of the modified pixel design. In the case of $\pm 0.33\text{V}$ threshold voltage variation of driving TFT, the output OLED current variation is negligible in the proposed circuit. The maximum deviation of the voltage at OLED anode is only 0.0117V . It verifies that the panel brightness is insensitive to the threshold voltage variation. Besides, there is no current flow through OLED during programming. Therefore, low power consumption compared with the first proposed circuit can be achieved. Fig. 4.18 shows the gate voltage in the capacitor for different values of ΔV_{th} (-0.33V , 0V , and $+0.33\text{V}$) when data voltage is 4V . The programming period is $10\ \mu\text{sec}$. After data input period, V_{gs} of TFT2 is $V_{\text{th_T2}}$ and the stored voltage in the capacitor is $V_{\text{data}} + V_{\text{th_T2}}$. It verifies that the modulated data voltage is stored in the capacitor when the threshold voltages of TFTs are varied and the difference in the resulting V_{g} is exactly the difference between the threshold voltages in TFTs.

Fig. 4.19 shows the range of current flowing through the OLED at different V_{data} and threshold voltage variation ($\Delta V_{\text{th}} = -0.33\text{V}$, 0V , and $+0.33\text{V}$). From the simulation result, it can be seen clearly that the proposed pixel circuit successfully reproduces almost identical OLED current regardless of the threshold voltage variation of TFTs and a wide range of data voltage can be used.

Fig. 4.20 plots the simulation results of the modified pixel design. The error rate is defined as current variation owing to ΔV_{th} divided by original current. The output current errors due to threshold voltage variation in the conventional are all above 20% when input data voltage ranges from 0.5V to 5V , while those are very small and below 3% in the modified proposed pixel circuit.

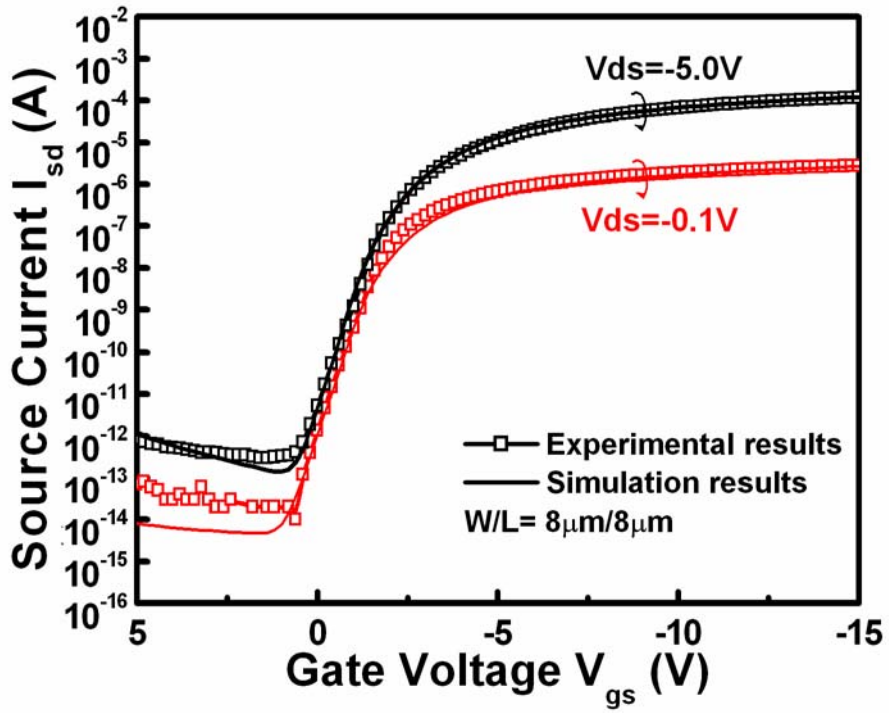

Fig. 4.16. The measured and simulated transfer characteristics of p channel TFTs.

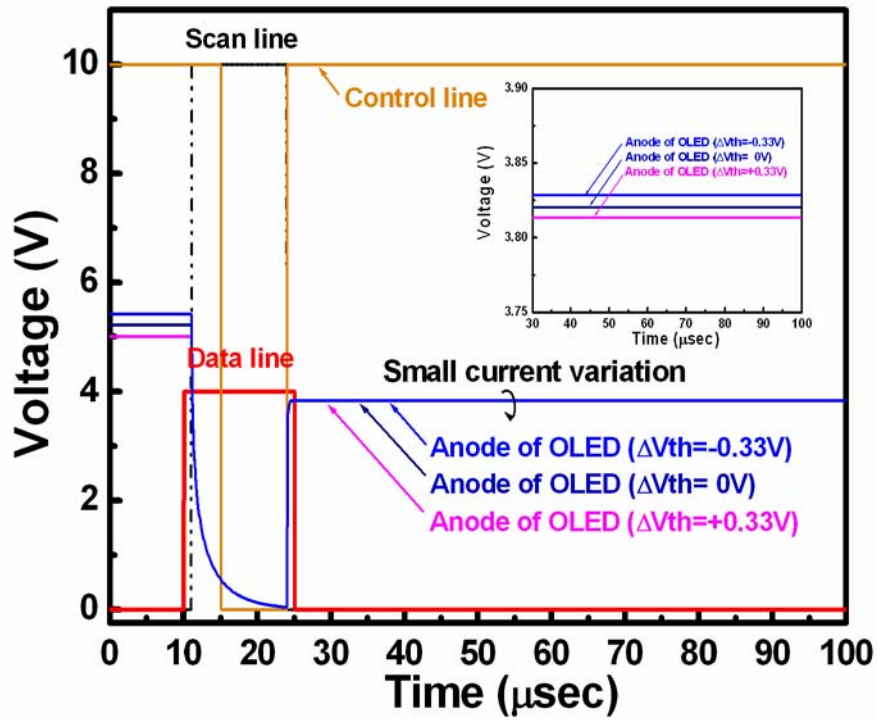

Fig. 4.17. Transient response of the modified pixel design.

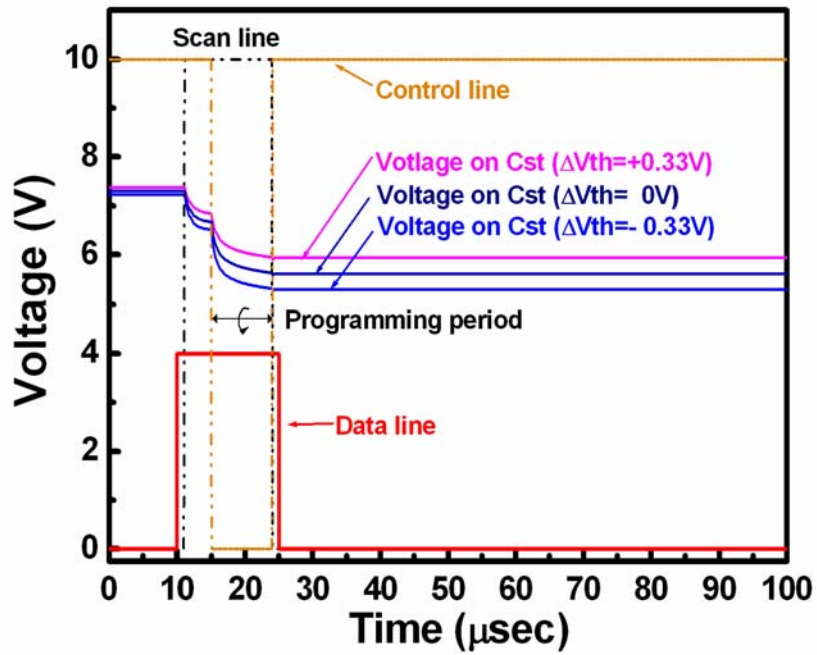

Fig. 4.18 The gate voltage in the capacitor for $\pm 0.33\text{V}$ threshold voltage fluctuations.

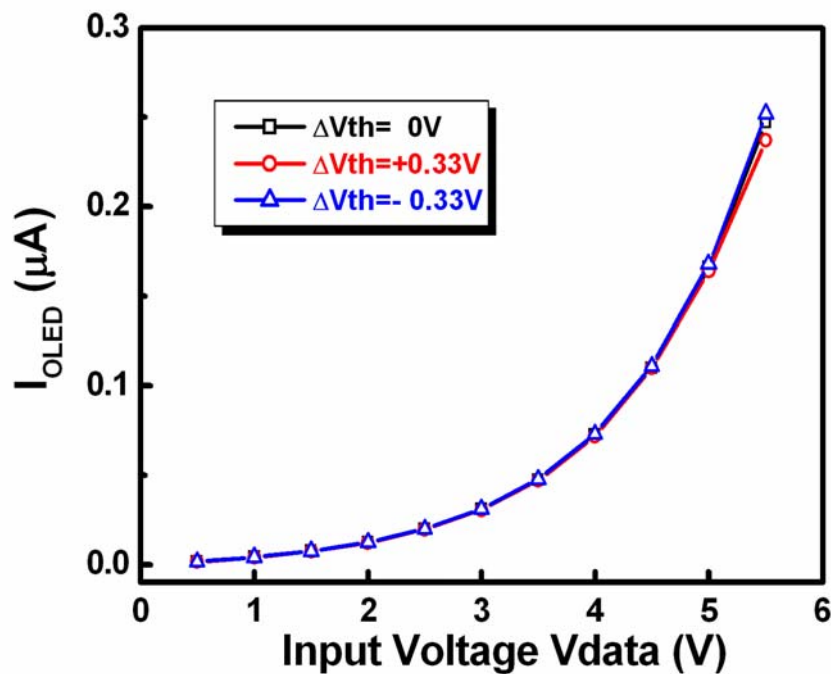

Fig. 4.19. Simulation results showing the range of current flowing through the OLED at different V_{data} and threshold voltage variation ($\Delta V_{th} = -0.33\text{V}$, 0V , and $+0.33\text{V}$).

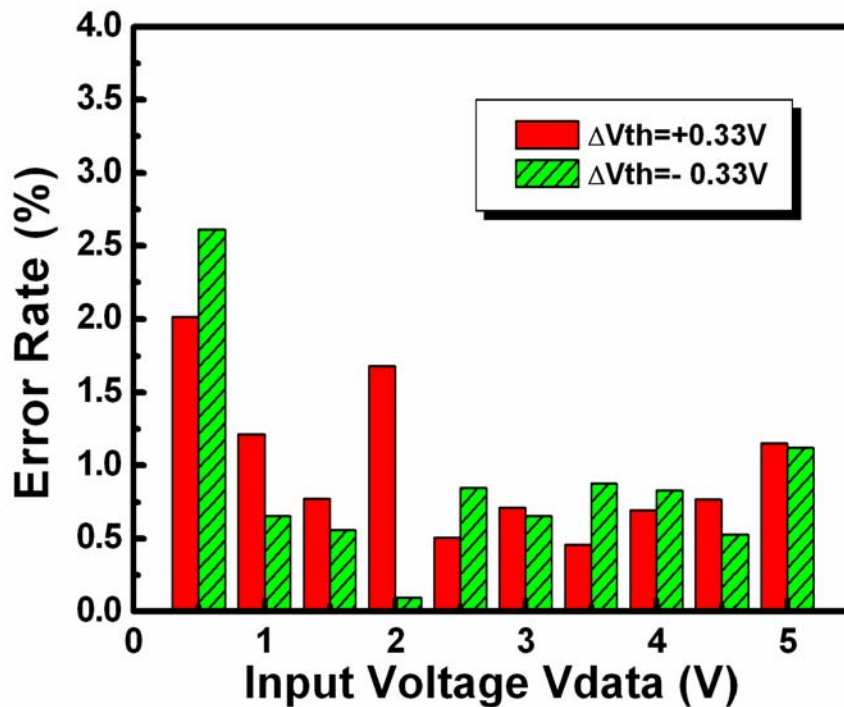

Fig. 4.20. The error rate of output current in our proposed pixel circuit due to the threshold voltage variation when input data voltage ranges from 0.5V to 5V.

4.7.3 Comparison between the Two Proposed Pixel Circuits and Other Pixel Circuit Design

Performance such as non-uniformity and power consumption of the proposed two pixel designs, conventional 2T1C pixel design, and Lee's proposed circuit [2.33] are compared. In Lee's circuit, seven transistors and one capacitor are used. It also compensates for the voltage degradation with the diode connected concept. T6 and T7 are employed to make a current path through T2, T4, T6, and T7 during pre-charging period. Fig. 4.17 shows the non-uniformity of the output current for $\pm 0.33V$ threshold voltage fluctuations. Among the pixel designs, there is a significant improvement in the proposed pixel circuits. Fig. 4.18 shows the power dissipation of the compared circuit designs for different input data voltages.

Although the power consumption in the proposed pixel designs is higher than that in the conventional design. It already reduces effectively the power consumption compared with the Lee's 7T1C pixel design. Because the modified circuit can block any current through TFT5 and OLED, power reduction can further be obtained as shown in 4.19

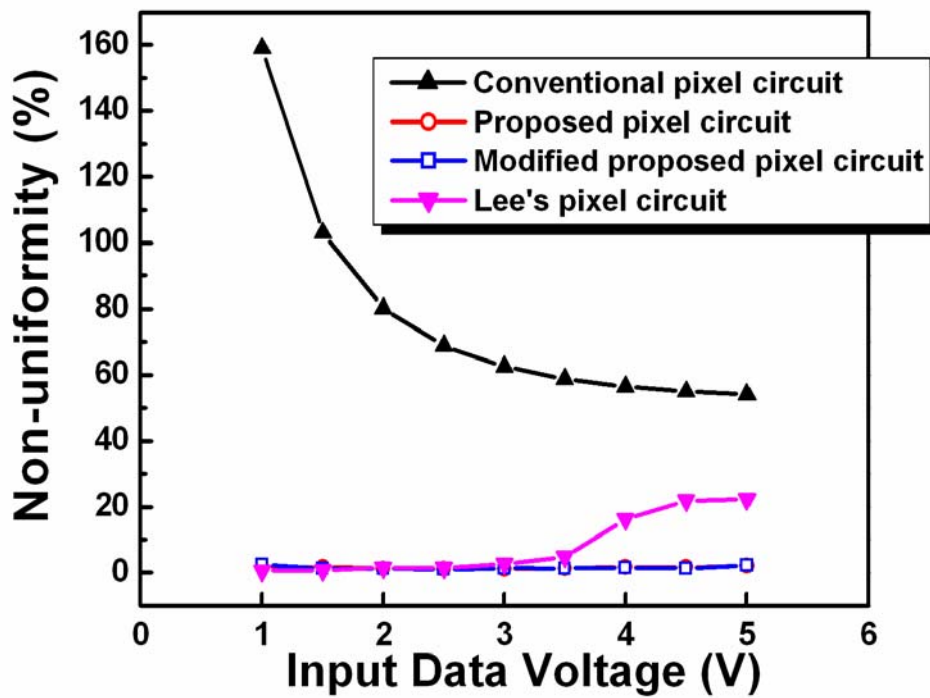

Fig. 4.21. Non-uniformity of the output current for $\pm 0.33V$ threshold voltage fluctuations.

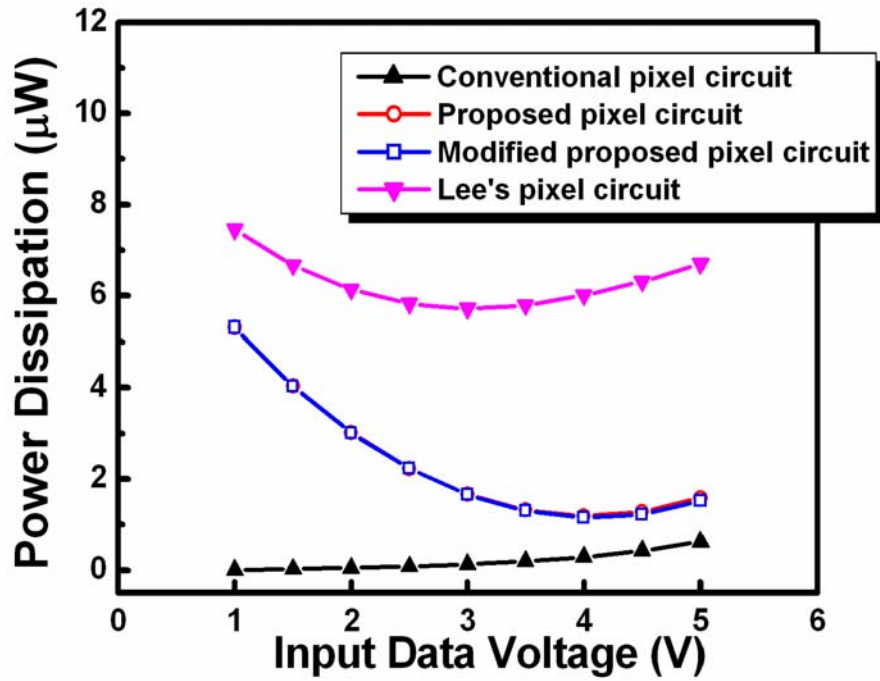

Fig. 4.22. Power dissipation of the circuit designs for different input data voltages.

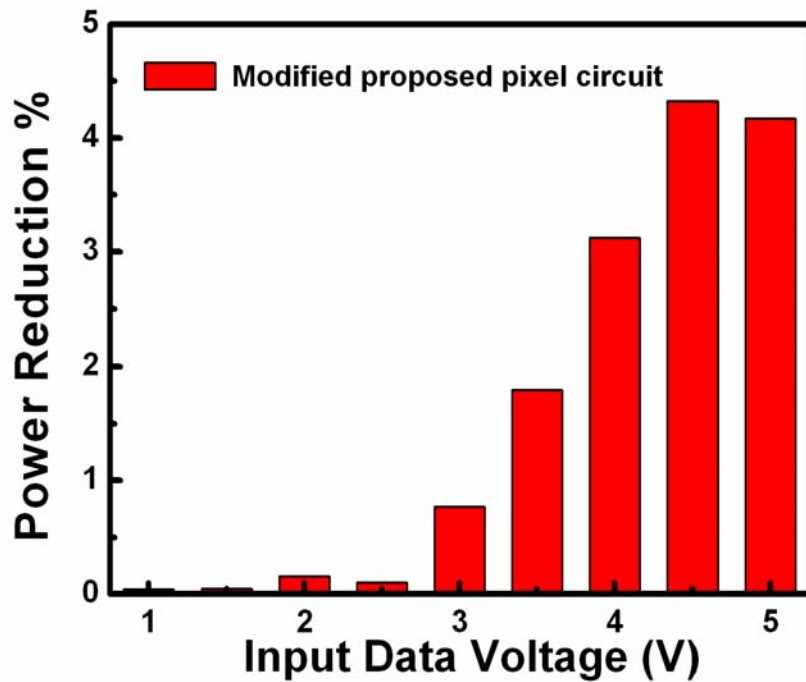

Fig. 4.23. Power reduction of the modified circuit design compared with the first one.

4.8 Summary

New voltage programming pixel designs for AMOLED using LTPS TFTs, which consists of 5TFTs, one capacitor and one OLED have been proposed to obtain uniform brightness image across the panel even in the presence of spatial variation of threshold voltages. Besides the necessary scan line, only one additional control signal was used. The proposed circuits compensate for the threshold voltage variation of LTPS TFTs by itself with a simple driving scheme and solve the mismatch problem of TFT electrical characteristics between the driving transistor and compensating transistor in the same pixel. The simulation results based on the measurement of OLED and LTPS TFTs electrical characteristics verified that the proposed circuit designs successfully produced almost identical output OLED current regardless of threshold voltage variation in TFTs. Moreover, by experimental results, the non-uniformity can be suppressed to less than “ 10% ”. By means of using modified pixel design which replaced a n channel TFT with a p channel TFT in order to block the current flow path through OLED during pre-charge period, lower power consumption can be obtained. The circuit designs are suitable for the AMOLED panel in the future.