

圖 4.1 柱試體接合細部



圖 4.2 試體一 CM600 協力桿件配置圖



圖 4.3 試體一 CM600 梁柱接合細部

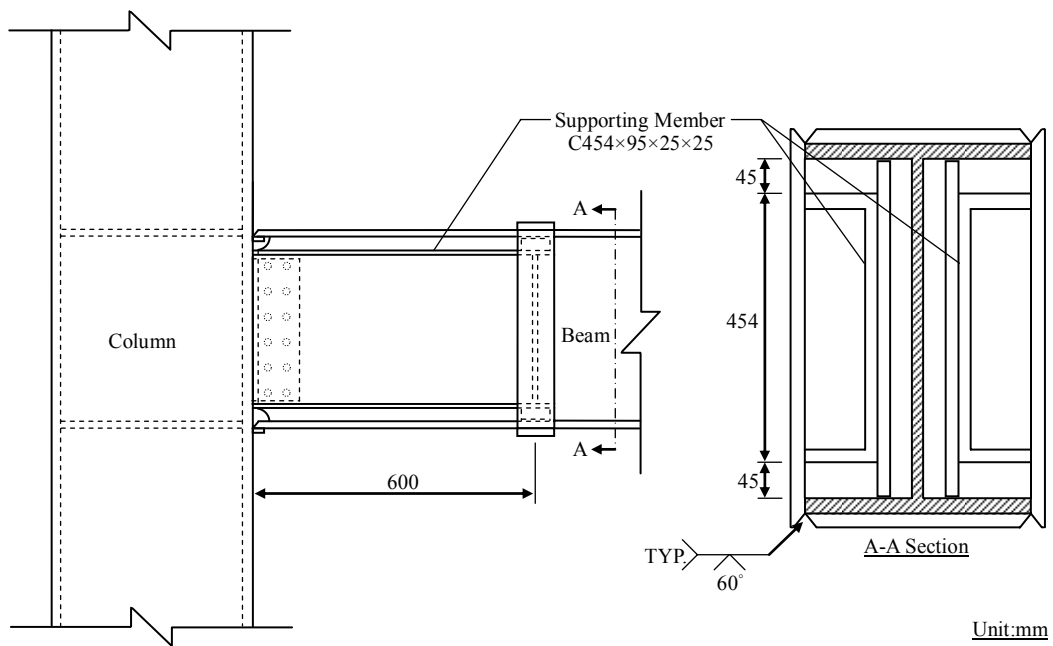

圖 4.4 試體一 CM600 協力桿件接合細部

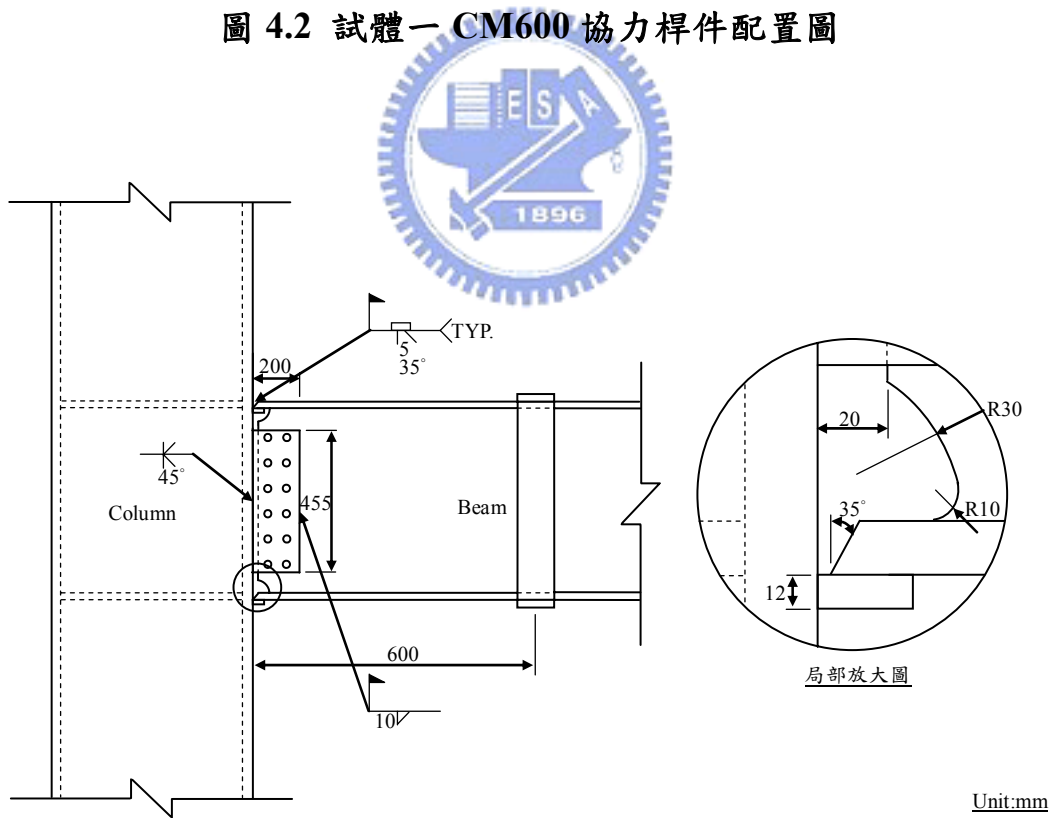

圖 4.5 試體二 BS600 協力桿件配置圖

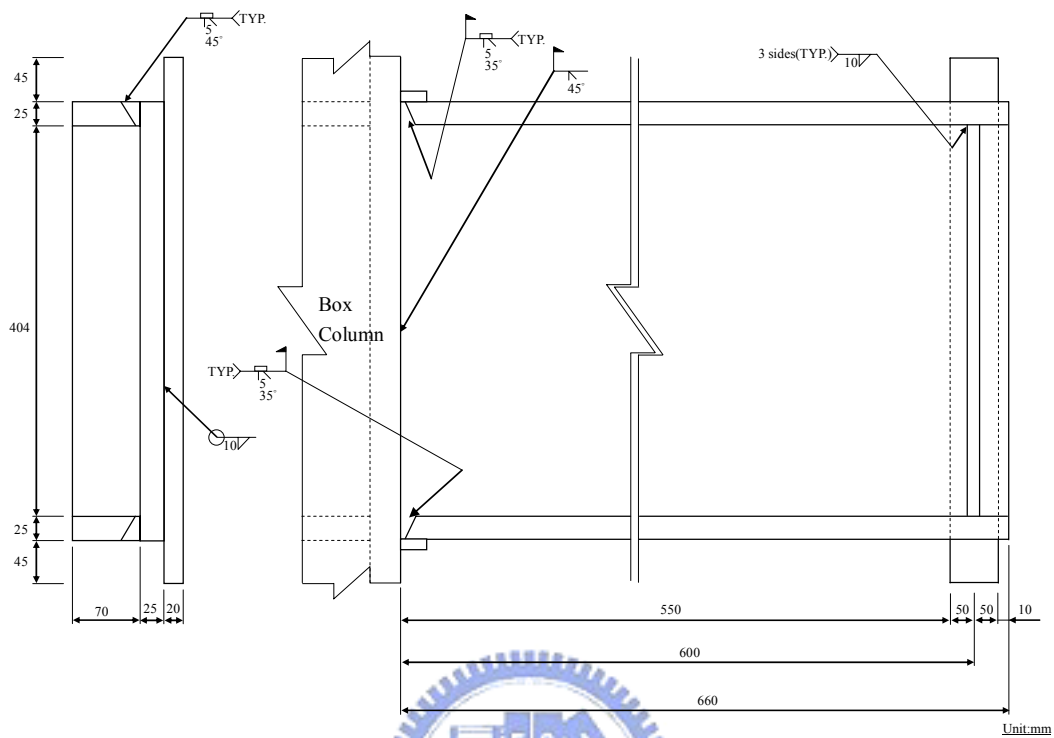

圖 4.6 試體二 BS600 梁柱接合細部

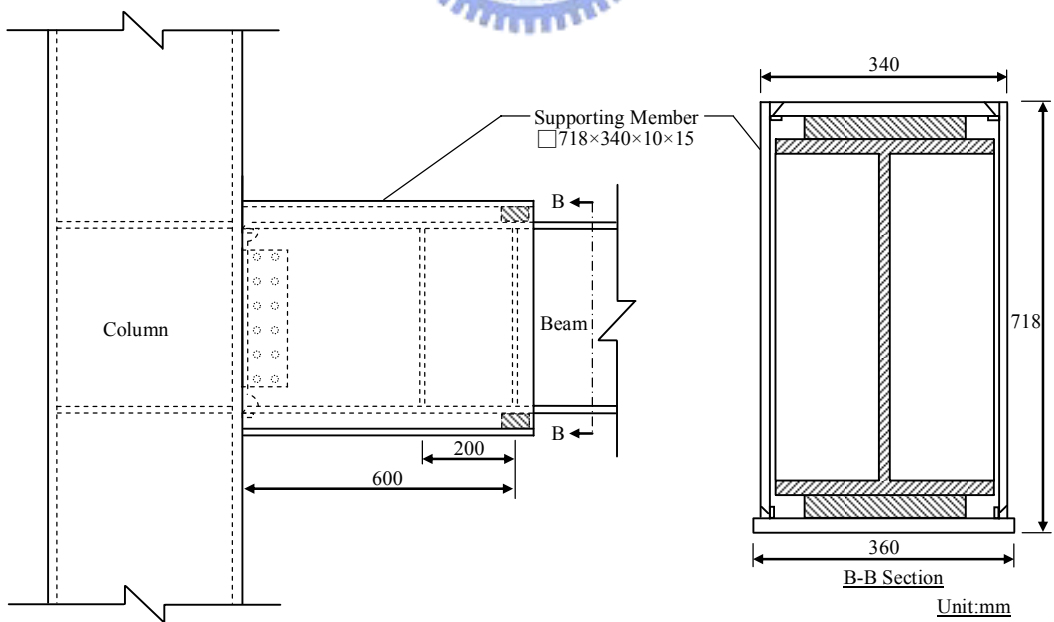

圖 4.7 試體二 BS600 協力桿件接合細部

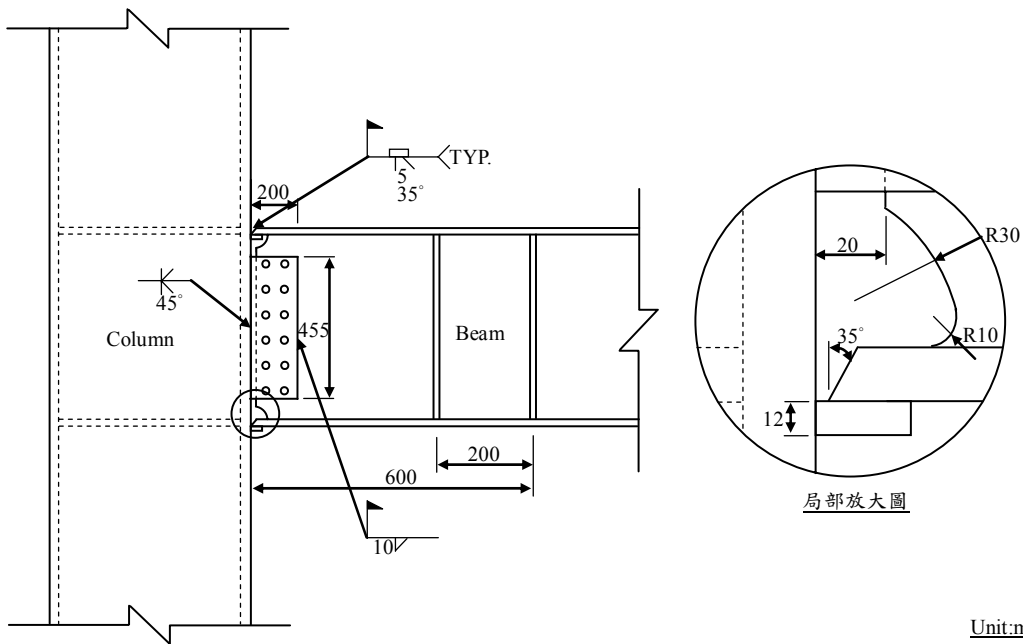

圖 4.8 梁腹板拉力試片應力-應變曲線

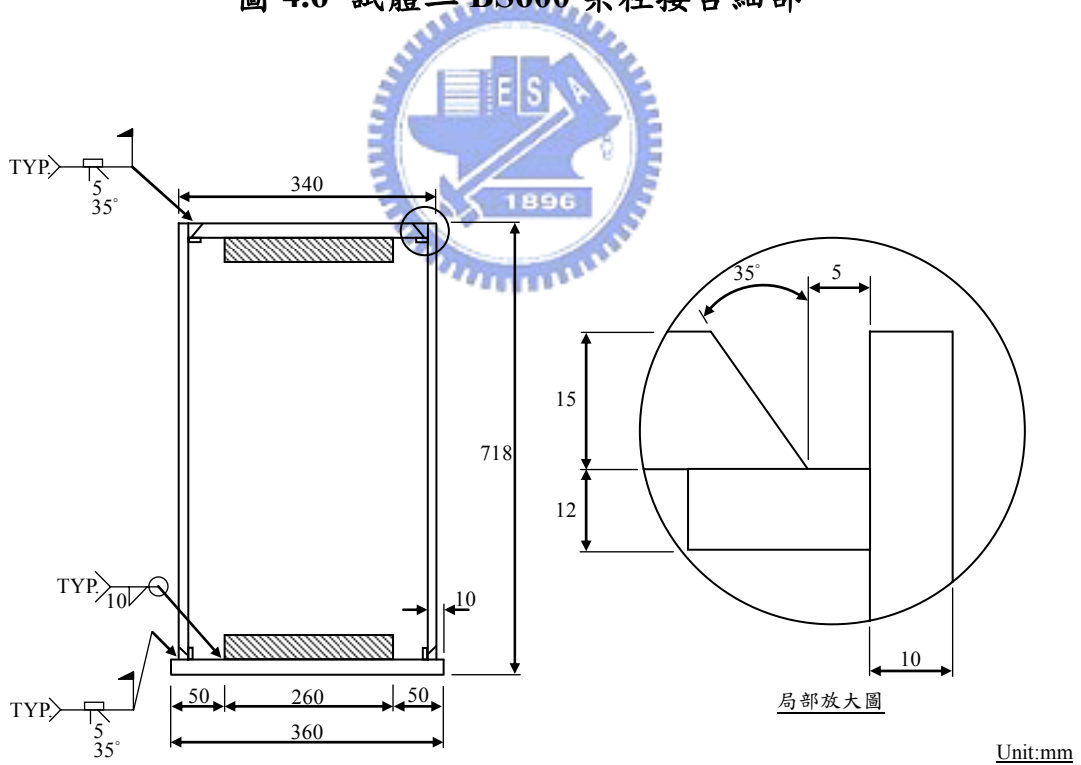

圖 4.9 試驗配置圖

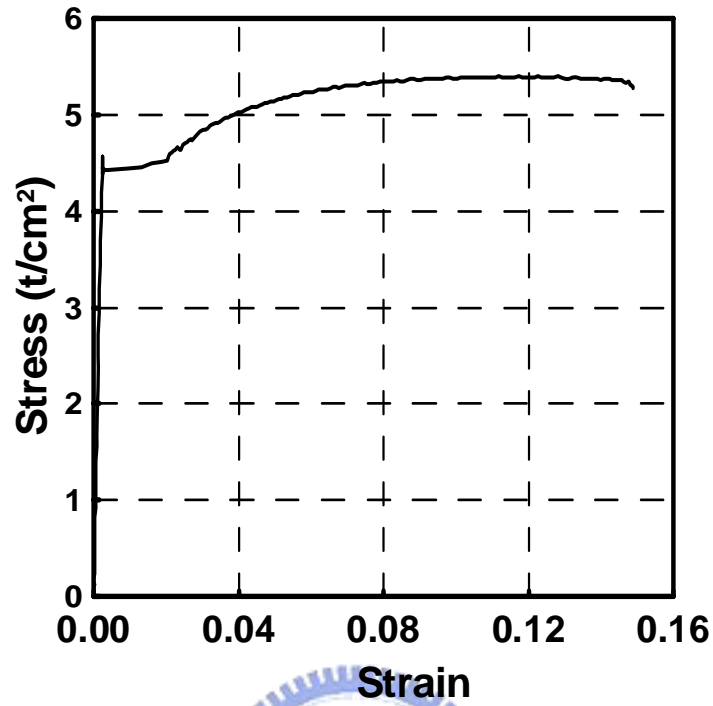

圖 4.10 量測儀器配置圖

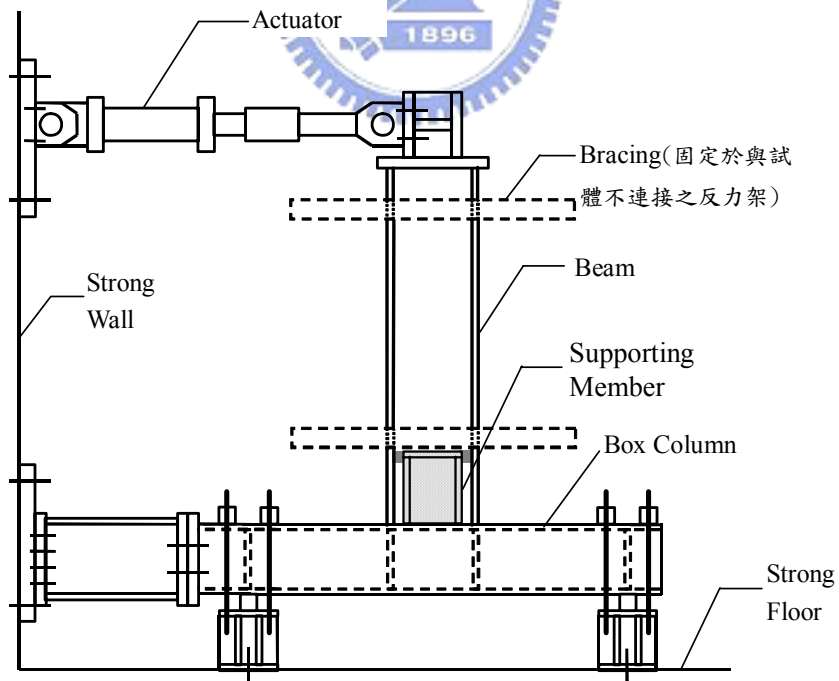
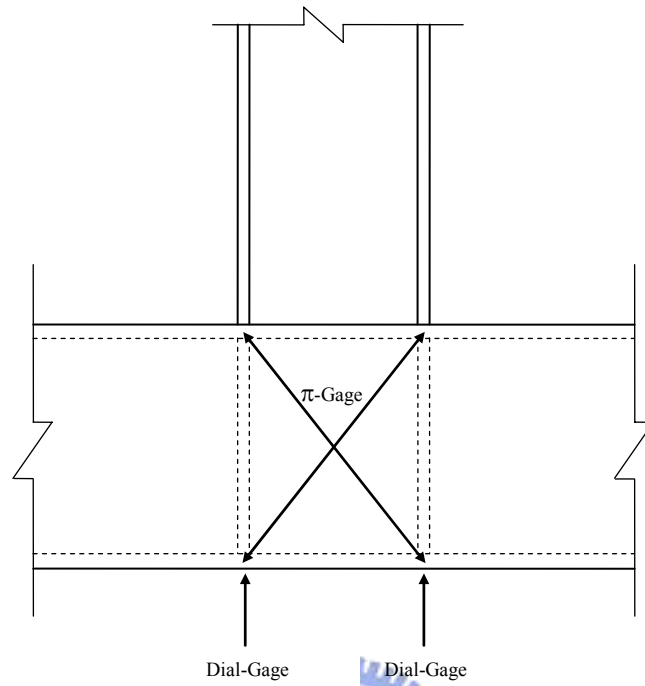
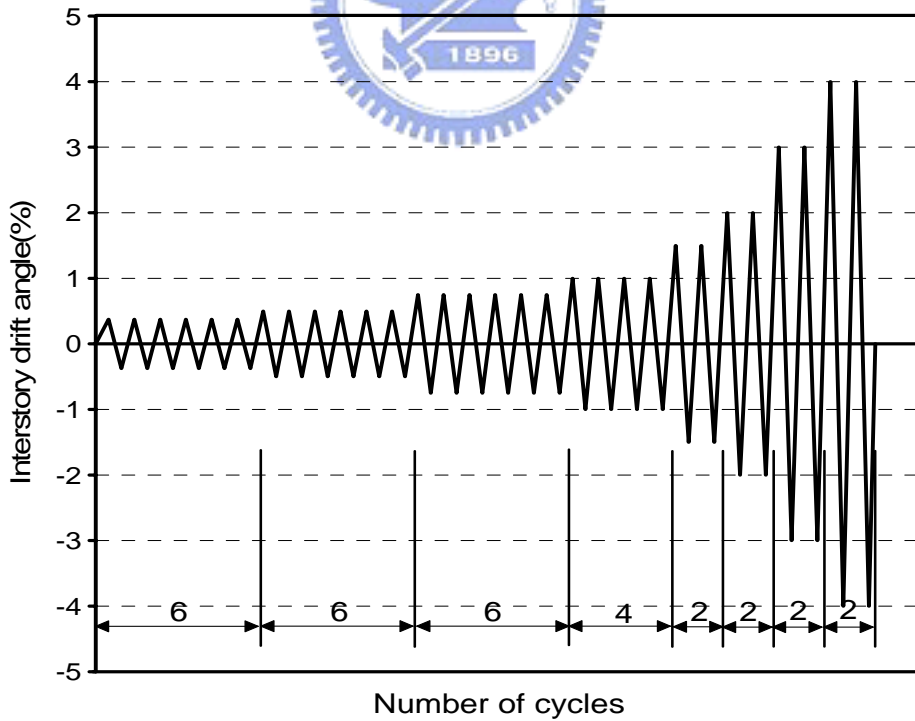

圖 4.11 位移控制歷程圖