

圖 3.1 ECR-CVD 系統[由林兆焄提供]



圖 3.2 觸媒濺鍍系統(由鍊德鐘利群提供)



圖 3.3 實驗流程圖

APC: pressure controller  
 FV: valve between turbo pump  
 and mechanical pump 1  
 TP: turbo molecular pump  
 MP1: mechanical pump 1  
 MP2: mechanical pump 2  
 MV1: valve between turbo  
 pump and chamber  
 MV2: valve between mechanical  
 pump 2 and chamber

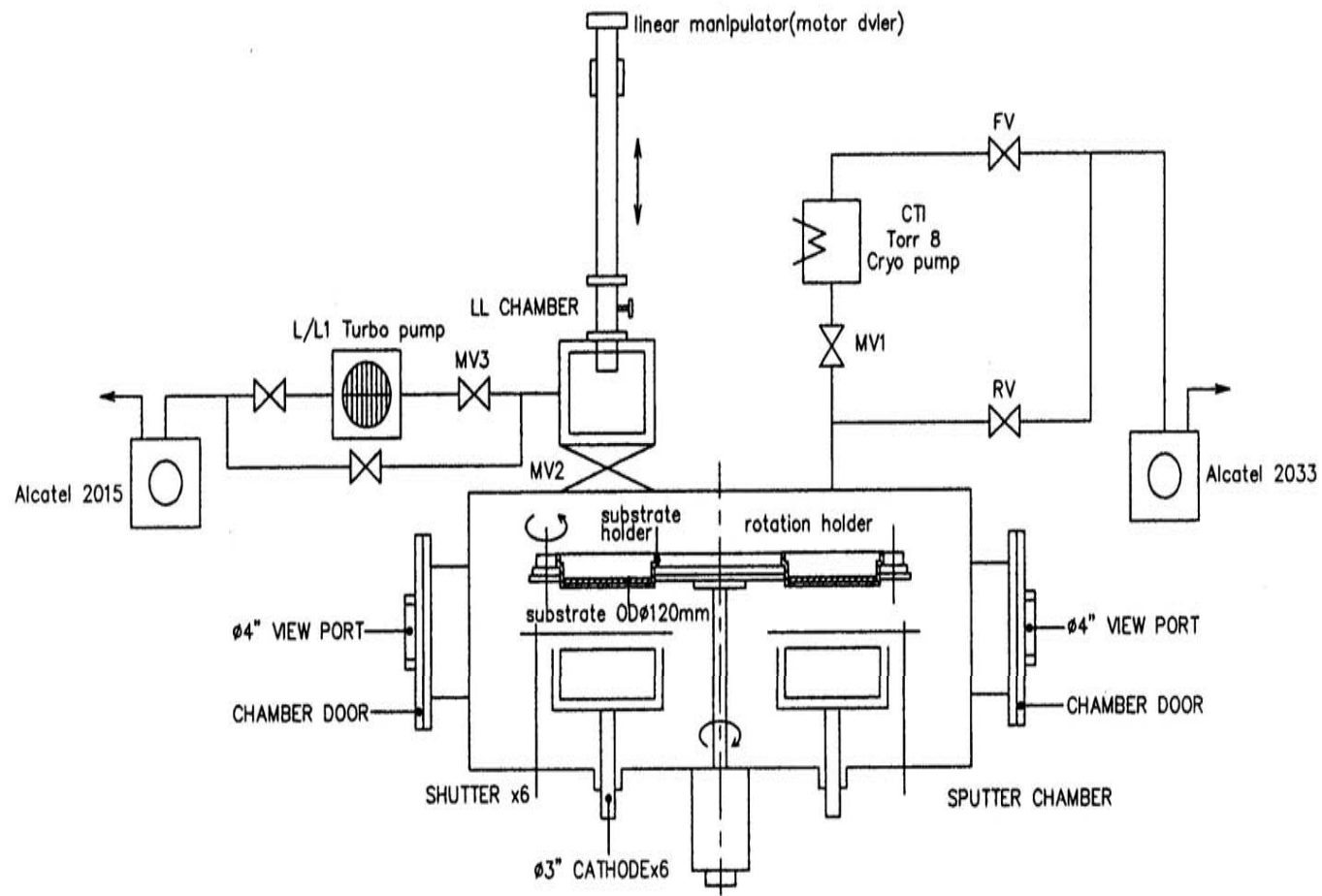
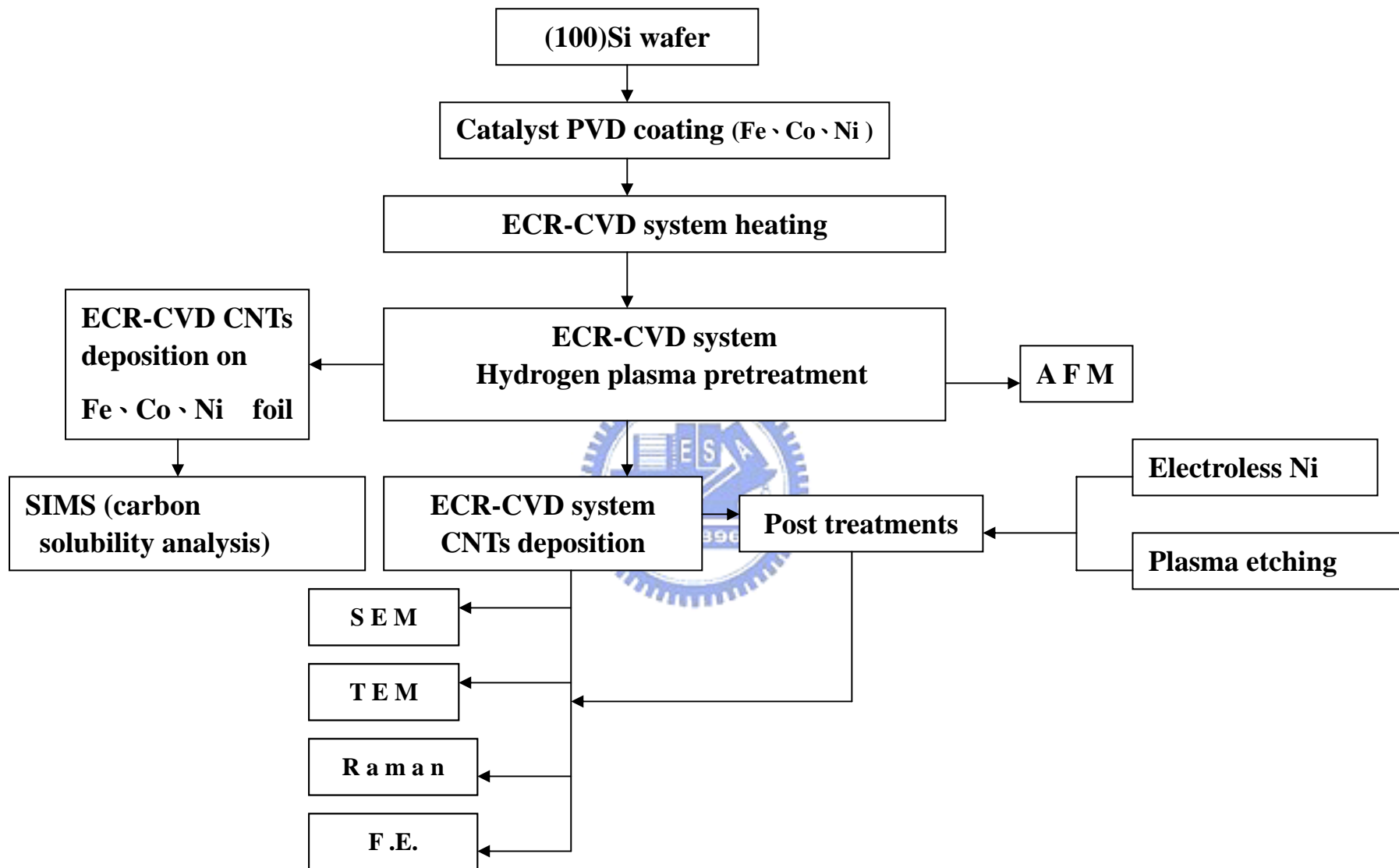
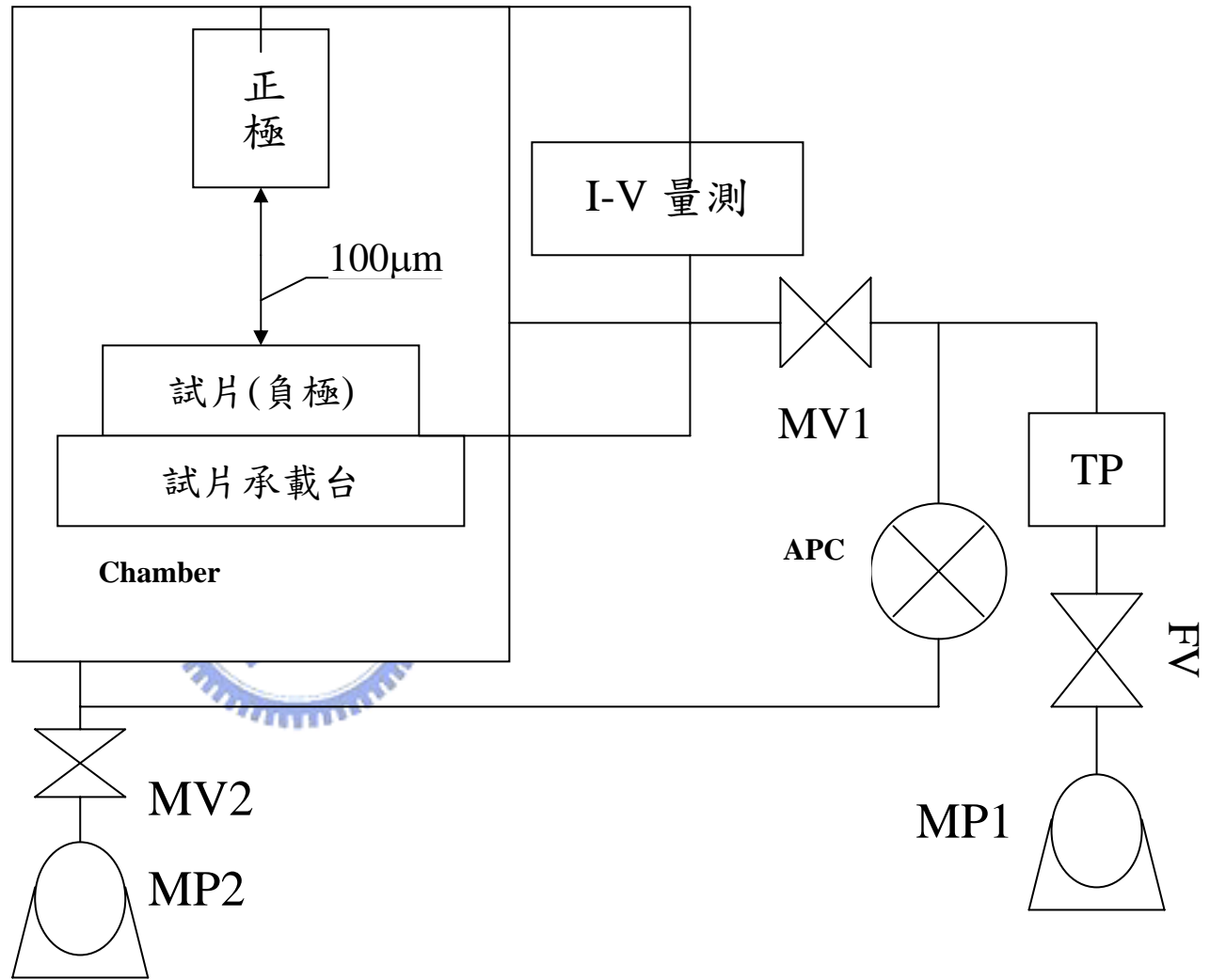

圖 3-4. 場發射量測系統[由張惠林提供]