

Chapter 2

Wavelength Tunable Laser using FPLD

2.1 Linear-Cavity Fiber Laser Scheme

In this section, we demonstrate a simple configuration of a wavelength-tunable mode-locked linear-cavity fiber laser by using a FPLD. The linear-cavity fiber laser scheme is implemented via the fiber loop mirror and FPLD as a cavity mirror. The wavelength tunable is achieved by the tunable bandpass filter. The proposed scheme is easy to be constructed and has a wide tuning range. The performance of the linear-cavity fiber laser operated at the different wavelengths is reported.

2.1.1 Experimental Setup

Figure 2.1 shows the proposed configuration of the wavelength-tunable mode-locked fiber laser using a FPLD. In our experiment, the fiber laser consisted of an EDFA, a FPLD, a tunable bandpass filter (TF), and a fiber loop mirror with a polarization controller (PC) and a 2x2 optical coupler (C1) as a cavity mirror. The fiber loop mirror is used to construct an external linear-cavity for providing feedback to the FPLD. The polarization controller is arranged for the reflectivity of this fiber loop mirror. The coupling ratio of the 2x2 coupler (C1) for the fiber loop mirror is 30:70. The lasing light emerging

from the 2x2 coupler arrives in an optical spectrum analyzer (OSA) and an oscilloscope with optical input port (86100A from Agilent Technologies). A 1480 nm laser diode with 70 mW output power pumps the 9 m EDF via a 1480/1550 nm WDM coupler (WDM). The operating range of the tunable bandpass filter (TB4500 from JDS Uniphase Co.) is from 1530 nm to 1562 nm. The average 3 dB bandwidth of the tunable bandpass filter is 0.4 nm. When the central wavelength is located at 1530 nm, 1545 nm, and 1560 nm, the insertion loss of tunable bandpass filter is 5.51 dB, 4.38 dB, and 2.49 dB, respectively. A 1550 nm commercial FPLD has a threshold current of 18 mA at 24 °C and a mode spacing of 0.78 nm. The radio frequency sinusoidal signal is used to drive the FPLD into gain-switching operation via a bias-tee circuit.

2.1.2 Results and Discussion

For simultaneous spectrum and waveform measurement, the output laser is split by a 1x2 coupler (C2) with coupling ratio 25:75 and measured by an optical spectrum analyzer (OSA) and an oscilloscope. The FPLD is biased slightly below the threshold 6.6 mA and gain-switched at 908.39 MHz. Fig. 2.2 shows the output spectrum of the gain-switched FP-LD. The fundamental frequency of this linear cavity is 3.74 MHz. The tunable bandpass filter is used within this cavity to select the lasing wavelength. When the central wavelength of the tunable bandpass filter is close to one of the wavelengths of the FPLD lasing modes, the output of the FPLD is limited to this specific wavelength. Thus the fiber laser only performs on single wavelength operation. Because of the FPLD self-seeded mechanism in combination with the tunable filter function, the linear-cavity fiber laser can stably generate short-pulse and is

easy to be tuned dynamically. Fig. 2.3 shows the output spectra and pulse waveforms when the central wavelength of the tunable bandpass filter is located at different FPLD lasing modes. The laser intensities and SMSR are not uniform due to cavity loss at different wavelengths and the gain profile of the FPLD and EDFA. The tuning range of this fiber laser is more than 27nm (from 1534.04 nm to 1561.48 nm). The SMSR and the pulsewidth as a function of wavelengths are shown in Fig. 2.4. The shortest pulsewidth is 53.2 ps with SMSR 34.5 dB. The variation of pulsewidth is caused by the different wavelengths with different mode-locked frequencies. Under the fixed modulation frequency, the fiber laser cannot be improved for a wider tuning range in the mode-locked mechanism. Nevertheless, we can add a variable optical delay line in the linear-cavity to control the cavity length so that the tuning range and repetition frequency will not limit by the mode-locked mechanism [1].

For the long-term stability, the pulse stability and characteristics can be improved by adding a polarization controller in the linear cavity. This polarization controller can be used to optimize the pulse characteristics because only one polarization direction of the feedback light results in the maximum efficiency of the FPLD [1-2].

In summary, we have demonstrated a novel and simple scheme to construct a wavelength-tunable mode-locked linear-cavity fiber laser. This wavelength-tunable output is implemented by using a self-seeded FPLD incorporated with an external fiber cavity. The tuning range of this fiber laser is over 27nm with SMSR up to 30 dB. The pulsewidth is between 53.2 ps and 80.4 ps at a repetition frequency of 908.39 MHz. We also discuss the variations of SMSR's and pulsewidths at different wavelengths.

2.2 Fiber Ring Laser Scheme

In this section, we present a configuration to generate wavelength-tunable optical pulses by an actively mode-locked fiber ring laser with an FPLD. The operating wavelength is selected by a tunable filter, and its intensity is enhanced by an EDWA [3-4]. Moreover, we add a variable optical delay line (VODL) in the fiber laser to control the cavity length so that the wavelength-tunable range and repetition frequency will not be limited by a fixed cavity length. Therefore, this fiber laser can have widely wavelength-tunable range and maintain a constant repetition frequency and pulsewidth at different wavelengths. The performance of this fiber laser operated at the different wavelengths is reported.

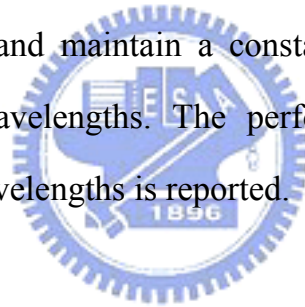

2.2.1 Experimental Setup

Figure 2.5 shows the proposed configuration of the actively mode-locked fiber ring laser. In our experiment, the fiber ring laser consisted of an EDWA, an FPLD, a tunable filter (TF), a VODL, an optical circulator (C), a polarization controller (PC), and a 1x2 coupler (C1) with coupling ratio 50:50. Fig. 2.6 shows the schematic diagram of the EDWA. The EDWA with a saturated output power 12 dBm is manufactured by Teem Photonics via a two step ion exchanges process [4]. The tunable filter is a fiber Fabry-Perot tunable filter. The insertion loss of tunable filter is 1.9 dB. The free spectral range (FSR) and 3 dB bandwidth of tunable filter are 48.7 nm and 0.53 nm,

respectively. The FPLD used is a commercial 1550 nm device (from Appointech, Inc.) with a threshold current of 18 mA at 25 °C and a mode spacing of 0.8 nm. Furthermore, it does not have antireflection coating. The radio frequency (RF) sinusoidal signal is used to drive the FPLD into gain-switching operation via a bias-tee circuit. The polarization controller is used to optimize the output SMSR because only one polarization direction of the feedback light results in the maximum efficiency of FPLD. The manual VODL (from General Photonics Corp.) is used to control the round trip pulse propagation time. The insertion loss of VODL is 1.2 dB.

Figs. 2.7 (a) and (b) show the fiber laser without VODL and with VODL, respectively, for comparison. Fig. 2.7 (a) shows the fiber laser without VODL when the central wavelength of the tunable optical filter is at different FPLD lasing modes. Because different wavelengths propagate in the cavity at different speeds, the feedback pulse is difficult to overlap with the emission pulse at different wavelengths. Therefore, the fiber laser without VODL did not maintain a constant repetition frequency and pulsewidth at different wavelengths. Fig. 2.7 (b) shows the fiber laser with VODL. The VODL can control the external cavity length and, hence, the fiber laser with VODL can maintain a constant repetition frequency and pulsewidth at different wavelengths. Furthermore, this fiber laser has a wide wavelength-tunable range.

2.2.2 Results and Discussion

For the simultaneous spectrum and waveform measurement, the output laser is split by a 1x2 coupler (C2) with coupling ratio 50:50 and measured by an optical spectrum analyzer (OSA) and a sampling oscilloscope with optical

input port (86100A from Agilent Technologies). The FPLD is biased slightly below the threshold 2.4 mA and gain-switched at 2000 MHz. Fig.2.8 shows the output spectrum of the gain-switched FPLD. The tunable filter is used to select the lasing wavelength. When the central wavelength of tunable filter is close to the one of wavelengths of the FPLD lasing modes, the output of FPLD is limited to this specific wavelength. Thus this fiber laser only performed on single wavelength operation. In our experiment, the optimum cavity length is selected that the fiber laser can generate the best SMSR by adjusting the VODL. Fig. 2.9 shows the output spectra and pulse waveforms when the central wavelength of the tunable filter coincides with one of the wavelengths of the FPLD lasing modes. The background of output spectra reflects the amplified spontaneous emission of the EDWA. Because the FSR of tunable filter is 48.7 nm, the small peak is observed when tunable filter is tuned to 1523.42 nm and 1570.16 nm. The intensities are not uniform due to cavity loss at different wavelengths and the gain profile of FPLD and EDWA. Furthermore, different injection power and wavelength to FPLD will generate different pulsewidth. In order to maintain the pulsewidth, we need slightly adjust the VODL at different wavelengths. The tunable range of this fiber laser is over 46 nm (from 1523.42 nm to 1570.16 nm). The SMSR and the pulsewidth as a function of wavelengths are shown in Fig. 2.10. The pulsewidth maintain around 45 ps at a repetition frequency of 2000 MHz. Overall, the proposed mode-locked fiber laser using a commercial FPLD as modulator is simple and cost effective. Such a fiber laser represents an economical alternative for the generation of widely wavelength-tunable optical short pulses.

In summary, we have demonstrated an actively mode-locked fiber laser with

an FPLD to generate wavelength-tunable optical pulses. The wavelength tunable is achieved by the tunable filter, and the EDWA is used as an optical amplifier in the fiber laser. In order to maintain a constant repetition frequency and pulsewidth at different wavelengths, the variable optical delay line is used to control the cavity length. The wavelength-tunable range of fiber laser is over 46 nm with SMSR over 33.5 dB. Furthermore, the pulsewidth maintain around 45 ps at a constant repetition frequency of 2000 MHz.

2.3 External-Injection Scheme

In this section, we present a simple system to generate wavelength-tunable optical pulses by a gain-switched FPLD in an external-injection scheme. An EDFA in the system is used as both an external-injection source and an amplifier for the FPLD, and a tunable filter is used as a wavelength selector. The lasing mode of the FPLD is locked by the backward ASE of the EDFA. The performance of system operated at the different wavelengths is reported. We also show the performance of the system without ASE injection.

2.3.1 Experimental Setup

Figure 2.11 shows the schematic diagram of the proposed system for the generation of wavelength-tunable pulses using a gain-switched FPLD and an EDFA. The system consists of an FPLD, a commercial tunable filter (TF), and an EDFA. The EDFA consists of an isolator, a 980 nm laser diode, and an erbium-doped fiber (EDF). The isolation and insertion loss of the isolator are

48 dB and 1 dB, respectively. In our experiment, the 980 nm laser diode with 50 mW output power pumps the 14-m-long EDF via a 980/1550 nm wavelength division multiplexing (WDM) coupler. The operating range of tunable filter (TB4500 from JDS Uniphase Co.) is from 1527 nm to 1562 nm. The average 3 dB bandwidth of the tunable filter is 0.4 nm. When the central wavelengths are 1530 nm, 1545 nm, and 1560 nm, the insertion losses of the tunable filter are 5.51 dB, 4.38 dB, and 2.49 dB, respectively. When the central wavelength of the tunable filter is close to one of the wavelengths of the FPLD lasing modes, the output of the FPLD is limited to this specific wavelength. Thus the system has a single wavelength output. Fig. 2.12 shows the measured spectra of the backward ASE and the ASE through the tunable filter. The spectrum of the ASE through the tunable filter is measured at the point “A” in Fig. 2.11. The FPLD used is a commercial 1550 nm device (from Appointech, Inc.) with a threshold current of 18 mA at 25 °C and a mode spacing of 0.8 nm. The radio frequency sinusoidal signal is used to drive the FPLD into gain-switching operation via a bias-tee circuit. The FPLD is biased at 15.8 mA and gain-switched at 2000 MHz. The spectrum of gain-switched FPLD is shown in Fig. 2.13 (a). The spectrum of FPLD through the tunable filter is shown in Fig. 2.13 (b), and the SMSR is only 17.5 dB. Fig. 2.13 (c) shows the measured spectrum at point “C” in Fig. 2.11. Because the EDFA is used as both an external-injection source and an amplifier for the FPLD, the SMSR and output peak power of the system are increased by 19 dB and 34.3 dB, respectively. Moreover, we add an additional isolator for the EDFA (see inset of Fig. 2.14) to reject the ASE injection. The output spectrum of system without ASE injection is shown in Fig. 2.14, and the SMSR is similar to the FPLD through the tunable filter. Hence the backward ASE injection can

effectively increase the SMSR and suppress the other lasing modes of FPLD.

2.3.2 Results and Discussion

For simultaneous spectrum and waveform measurement, the laser output is split by a 1x2 coupler (C) with coupling ratio 50:50 and measured by an optical spectrum analyzer (OSA) and a sampling oscilloscope with optical input port (86100A from Agilent Technologies). Fig. 2.15 shows the output spectra and pulse waveforms of the system when the central wavelength of the tunable filter is tuned to one of the wavelength of the FPLD lasing modes, and the background of output spectra reflects the ASE of the EDFA. The lasing wavelengths λ_1 , λ_2 , and λ_3 are 1527.13, 1545.05, and 1561.78 nm, and the pulsewidths are 49.4, 54.5, and 61.2 ps, respectively. The time-bandwidth products of the pulses are around 0.63, 0.76, and 0.60 at the lasing wavelengths 1527.13, 1545.05, and 1561.78 nm, respectively. The SMSR and intensities are not uniform due to different losses at different wavelengths and the gain profile of the FPLD and EDFA. The tuning range of this system is from 1527.13 nm to 1561.78 nm, and the average power of output pulses is between 7.81 dBm and 5.6 dBm. The SMSR and the pulsewidth as a function of wavelengths are shown in Fig. 2.16. The pulsewidth is between 49.3 ps and 65.3 ps at a repetition frequency of 2000 MHz. The wavelength-tunable range in our system is limited by the tunable filter because the gain profile of the FPLD and EDFA are over 34.5 nm (see Fig. 2.12 and Fig. 2.13 (a)). When the operating range of the tunable filter is larger, a larger wavelength-tunable range is expected.

The SMSR in this system is related to the bandwidth of tunable filter. The

narrower bandwidth of tunable filter may increase the SMSR. However, the thermal drift in the FPLD can induce the wavelength shift of FPLD. Using the narrower bandwidth of tunable filter has lower tolerance of the wavelength shift. Therefore, the bandwidth of tunable filter in this system needs to consider the SMSR, the thermal reliability, and the acceptable cost. Furthermore, the SMSR is also related to the ASE injection power. When the ASE injection power is increased, the SMSR increase simultaneously. Nevertheless, when the ASE power saturates, the SMSR will not increase. In our experiment, the ASE power is close to saturation when the 980 nm pump power is 50 mW, and the SMSR saturates around 36.5 dB at the wavelength 1545.05 nm. We also measure the level of timing jitter at the wavelength 1545.05 nm. When the pump power is 50 mW, the timing jitter is 1.64 ps. Moreover, the ASE injection power increases 0.96 dB at 1545.05 nm when the pump power increases from 50 mW to 65 mW. The timing jitter is 1.51 ps. The output pulses are stable at this level of pump power. In addition, we observe that the timing jitter decreases when the ASE injection power increases.

In summary, we have demonstrated a system to generate wavelength-tunable optical pulses using an FPLD and an EDFA. The wavelength tuning is achieved by the tunable filter, and the EDFA is used as both an external-injection source and an amplifier for the FPLD. The wavelength-tunable range of this system is over 34.5 nm with SMSR over 32 dB. The repetition frequency is 2000 MHz, and the pulsewidth is between 49.3 ps and 65.3 ps. The whole system is simple and can be easily constructed.

References

- [1] X. Fang and D. N. Wang, "Mutual pulse injection seeding by the use of two Fabry-Perot laser diodes to produce wavelength-tunable optical short pulses," *IEEE Photonics Technology Letters*, vol. 15, pp. 855–857, 2003.
- [2] S. Yang, Z. Li, X. Dong, S. Yuan, G. Kai, and Q. Zhao, "Generation of wavelength-switched optical pulse from a fiber ring laser with an F-P semiconductor modulator and a HiBi fiber loop mirror," *IEEE Photonics Technology Letters*, vol. 14, pp. 774–776, 2002.
- [3] Y. Jaouen, L. du Mouza, D. Barbier, J. M. Delavaux, and P. Bruno, "Eight-wavelength Er-Yb doped amplifier: combiner/splitter planar integrated module," *IEEE Photonics Technology Letters*, vol. 11, pp. 1105-1107, 1999.
- [4] C. M. McIntosh, J. M. P. Delavaux, G. C. Wilson, C. Hullin, B. Neyret, J. Philipsen, C. Cassagnettes, and D. Barbier, "High output power erbium doped waveguide amplifier for QAM distribution," *Optical fiber communication conference 2001 (OFC'2001)*, vol. 3, pp. WDD5-1-WDD5-3, 2001.

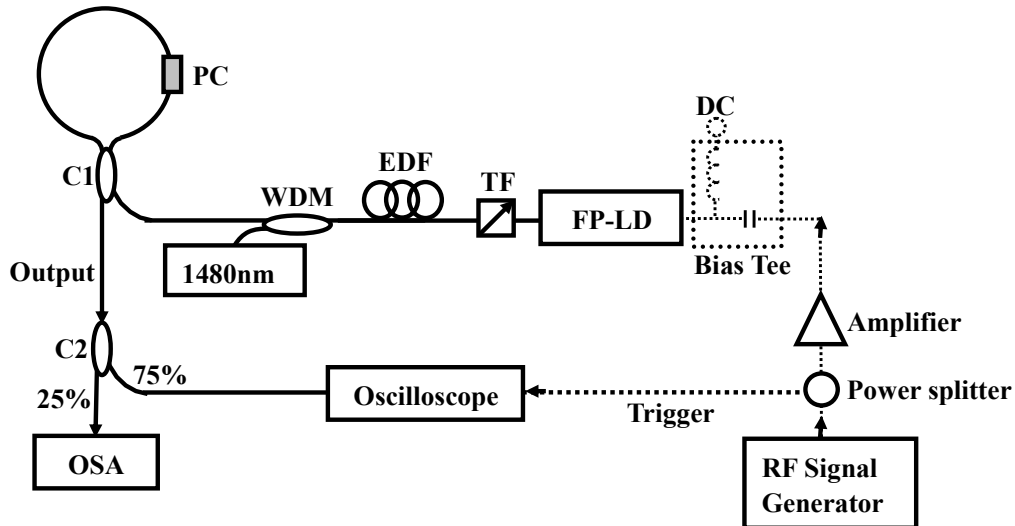

Fig. 2.1 Experimental setup of the wavelength-tunable mode-locked linear-cavity fiber laser. (PC: Polarization controller, C1: 2x2 coupler, C2: 1x2 coupler, EDF: erbium-doped fiber, TF: tunable bandpass filter, WDM: 1480/1550nm WDM coupler, FPLD: Fabry-Perot laser diode, OSA: optical spectrum analyzer).

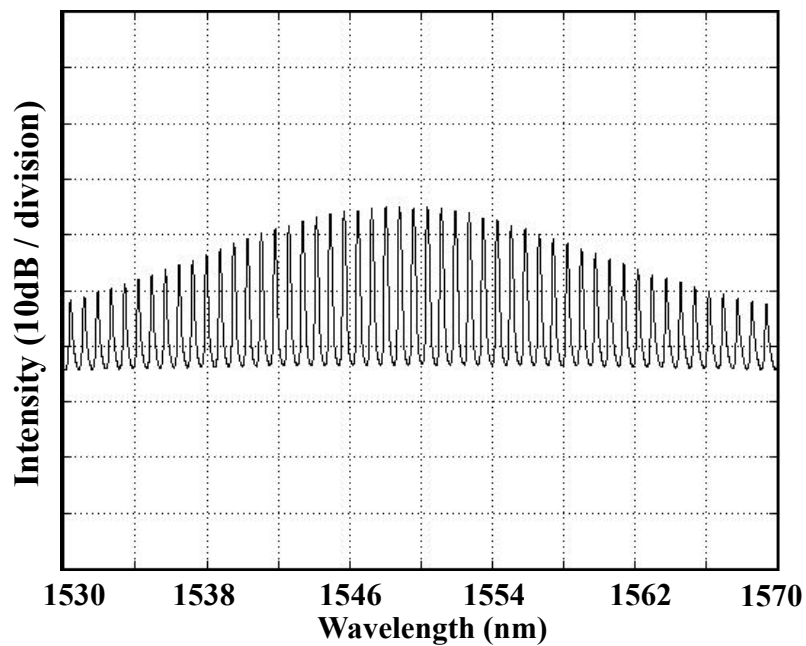

Fig. 2.2 Output spectrum of the gain-switched FPLD.

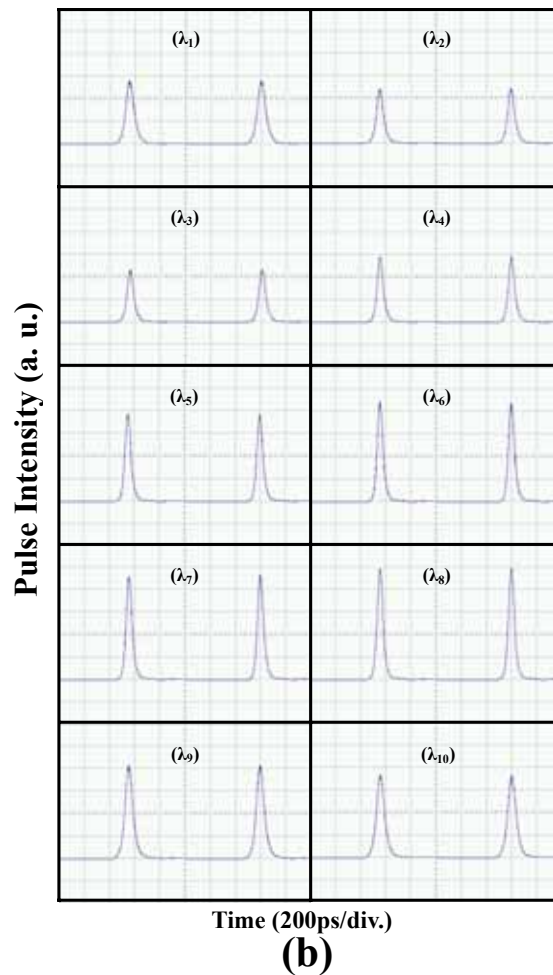
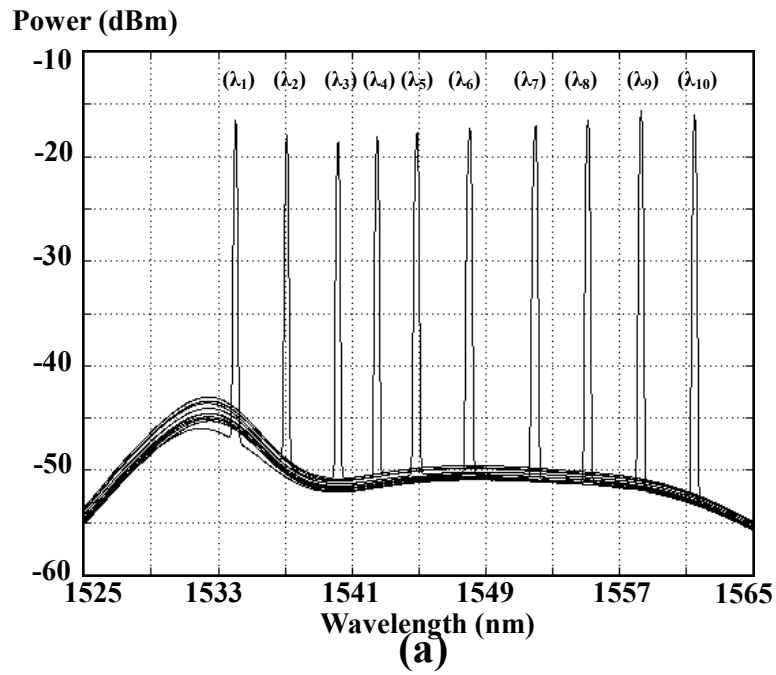

Fig. 2.3 Output spectra and pulse waveforms of the fiber laser when the central wavelength of the tunable bandpass filter is at different FPLD lasing modes. (a) Output spectra. (b) Pulse waveforms.

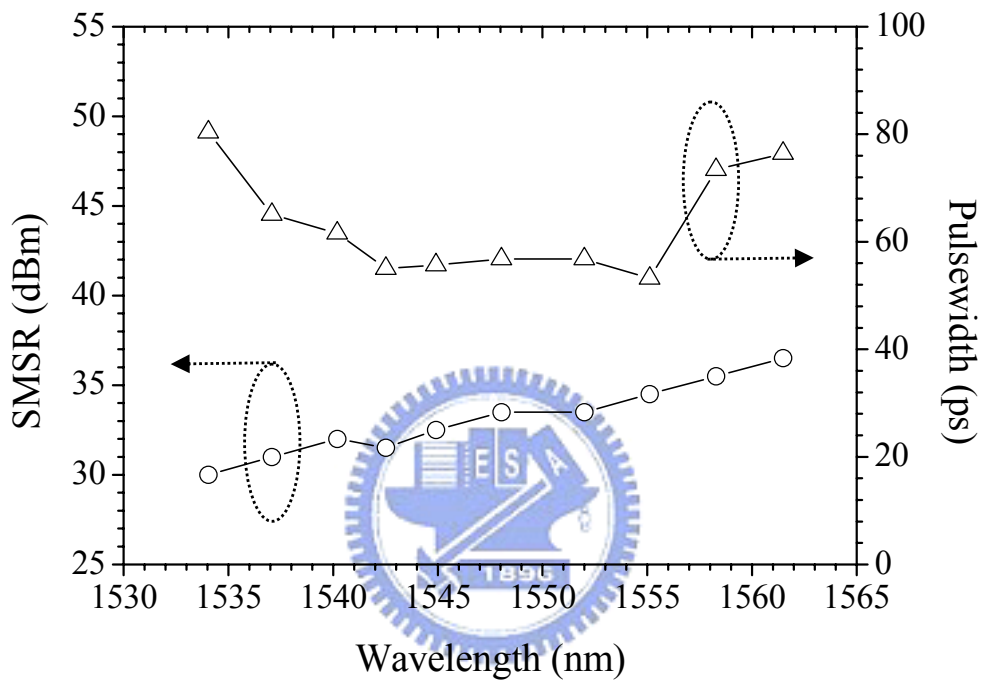

Fig. 2.4 The SMSR and pulsewidth as a function of wavelengths.

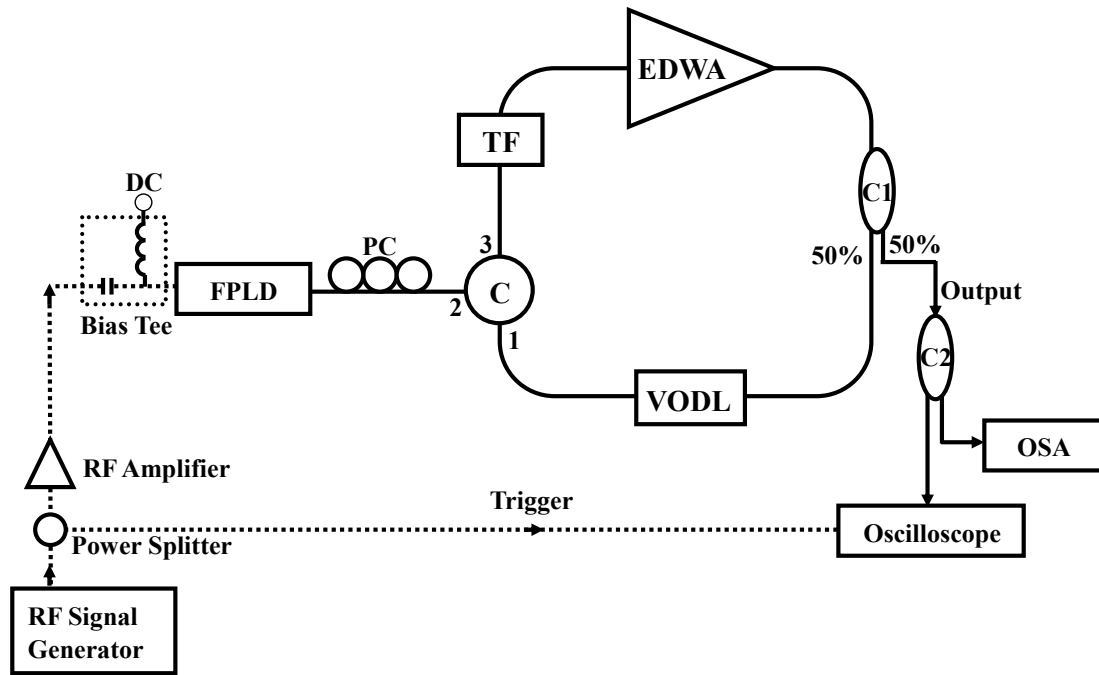

Fig. 2.5 Experimental setup of the wavelength-tunable mode-locked fiber ring laser. (FPLD: Fabry-Perot laser diode, PC: Polarization controller, EDWA: Erbium doped waveguide amplifier, TF: fiber Fabry-Perot tunable filter, VODL: variable optical delay line, C1: 1x2 coupler with coupling ratio 50:50, C2: 1x2 coupler with coupling ratio 50:50, OSA: optical spectrum analyzer).

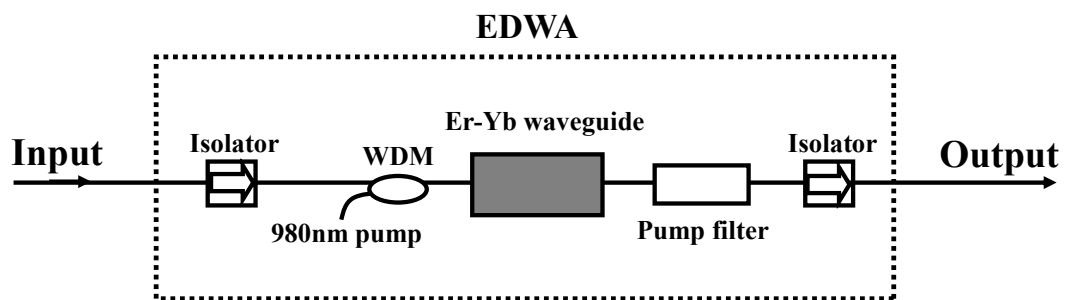
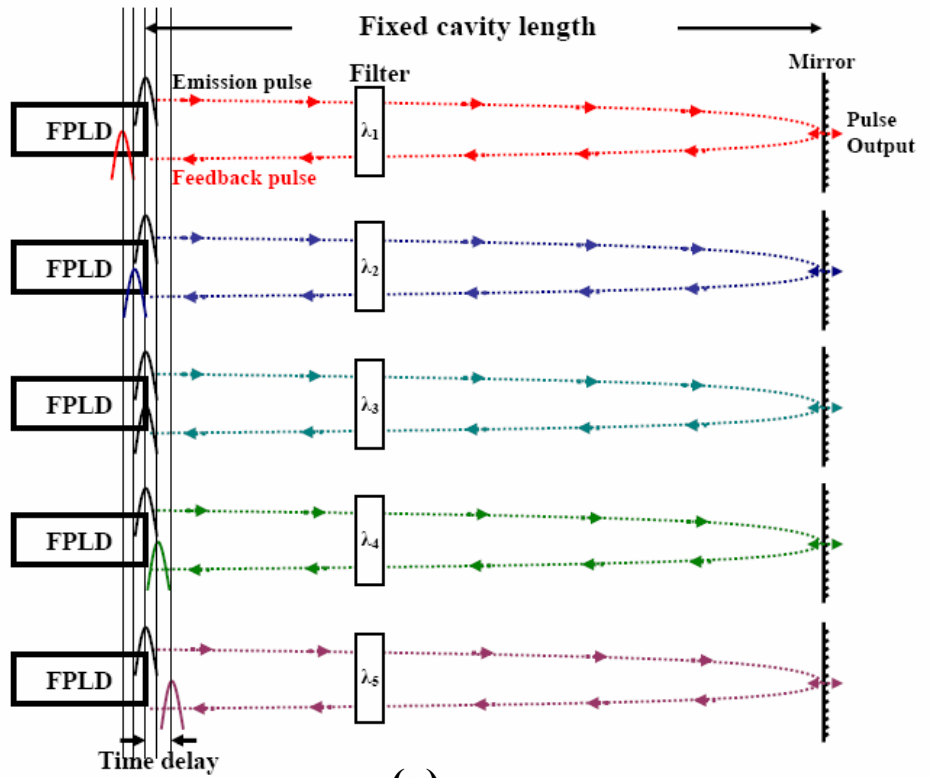
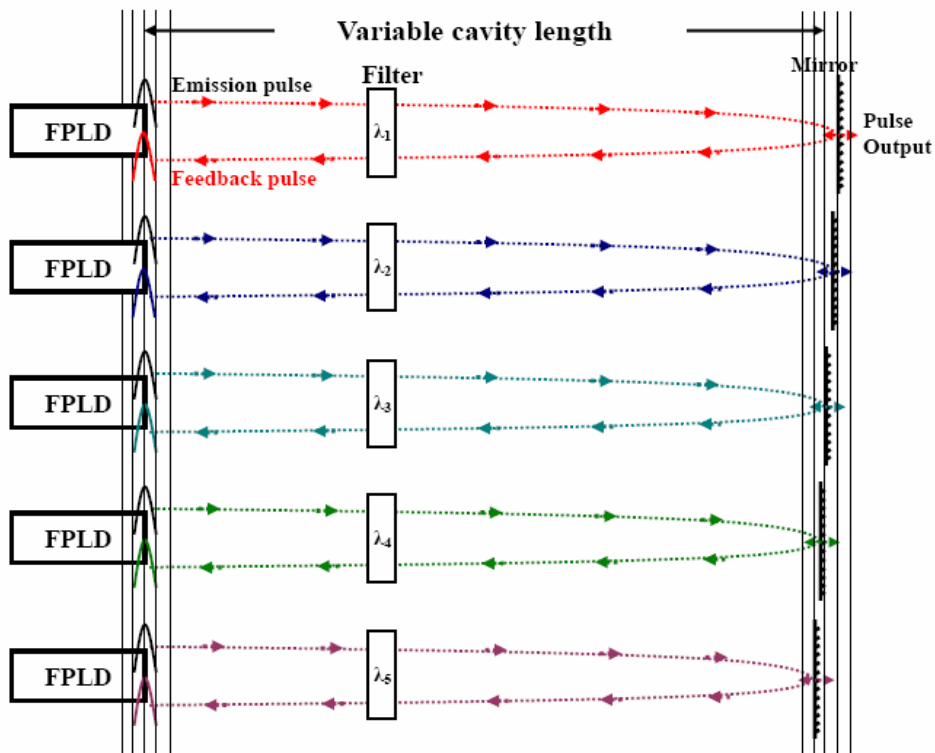

Fig. 2.6 Schematic diagram of the EDWA (WDM: 980/1550nm WDM coupler).



(a)



(b)

Fig. 2.7 Fiber laser (a) without VODL and (b) with VODL.

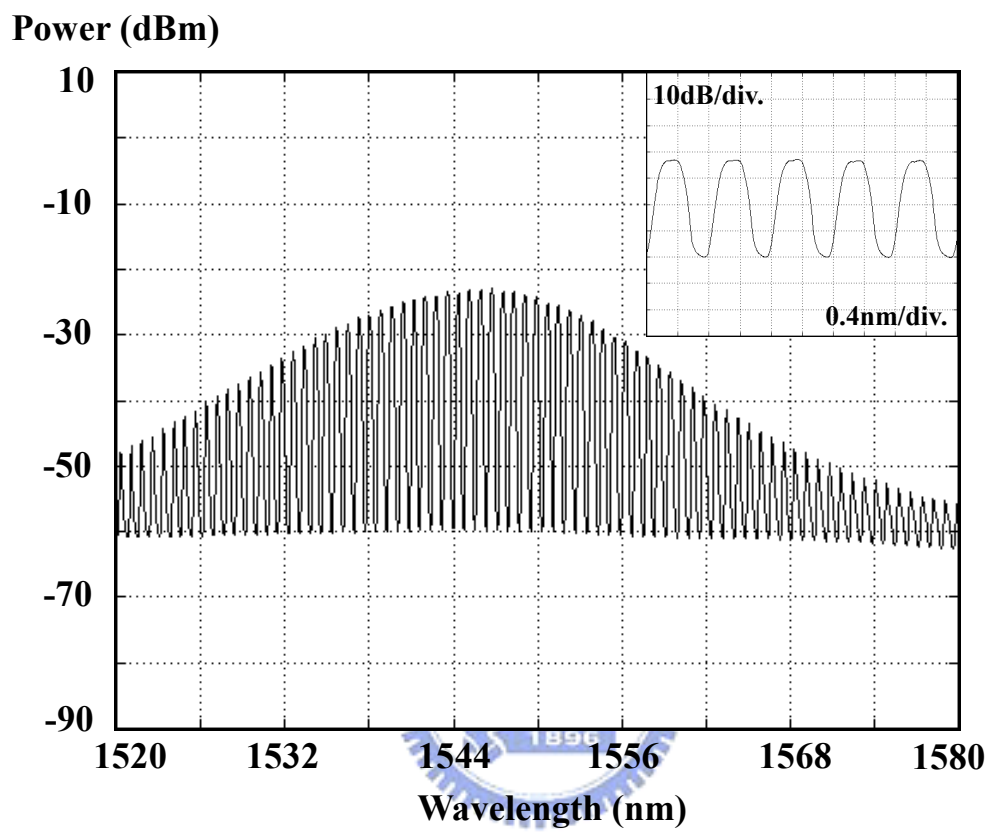

Fig. 2.8 Output spectrum of gain-switched FPLD.

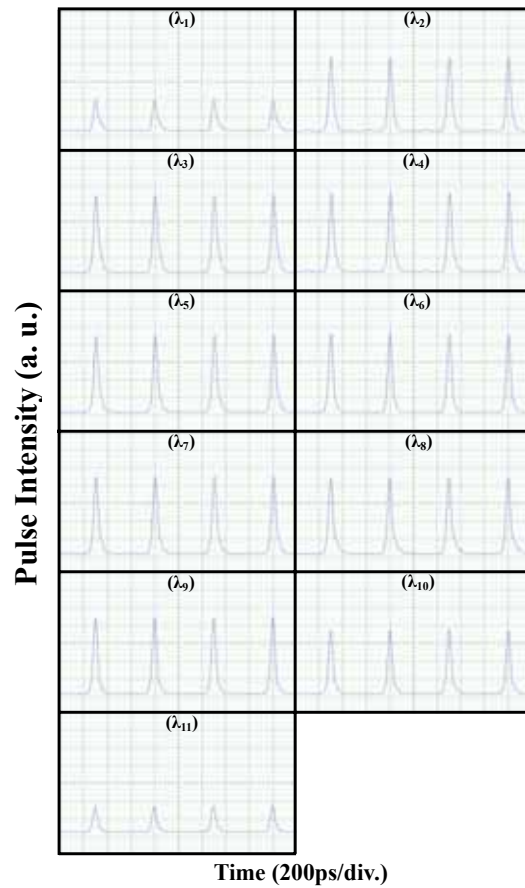
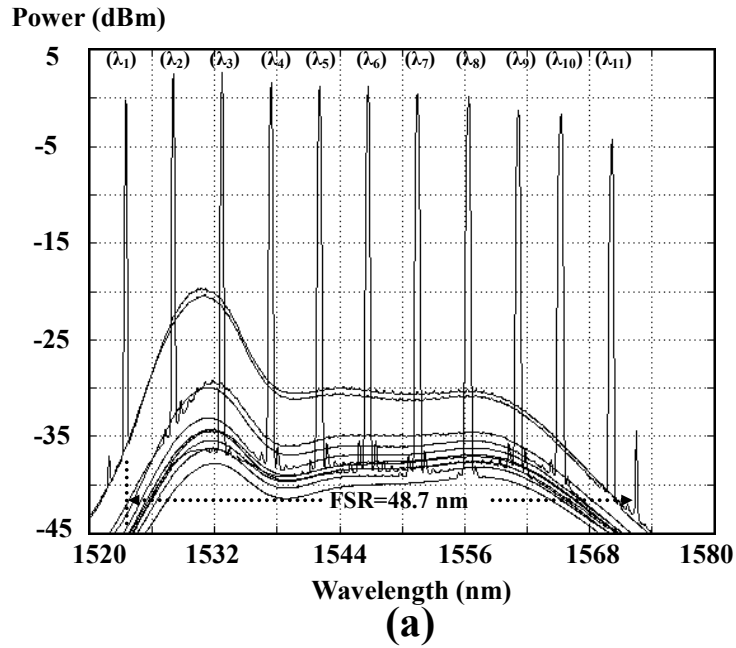

Fig. 2.9 (a) Output spectra and (b) pulse waveforms of the fiber ring laser when the central wavelength of the tunable filter coincides with one of the wavelength of the FPLD lasing modes.

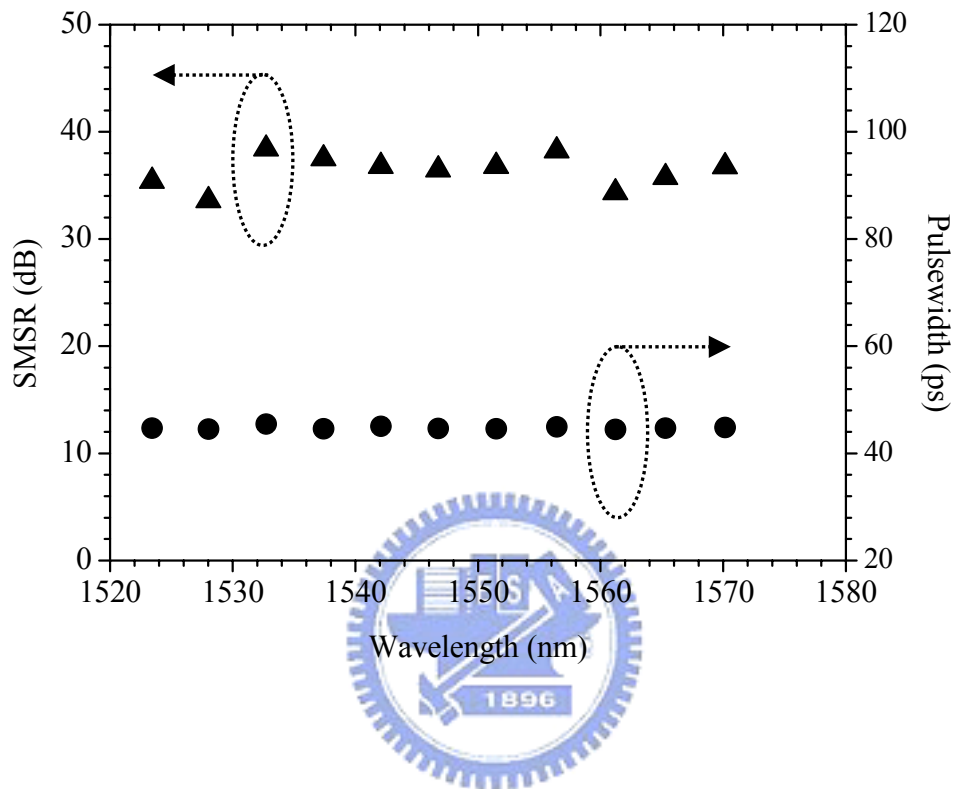

Fig. 2.10 The SMSR and pulsewidth as a function of wavelengths.

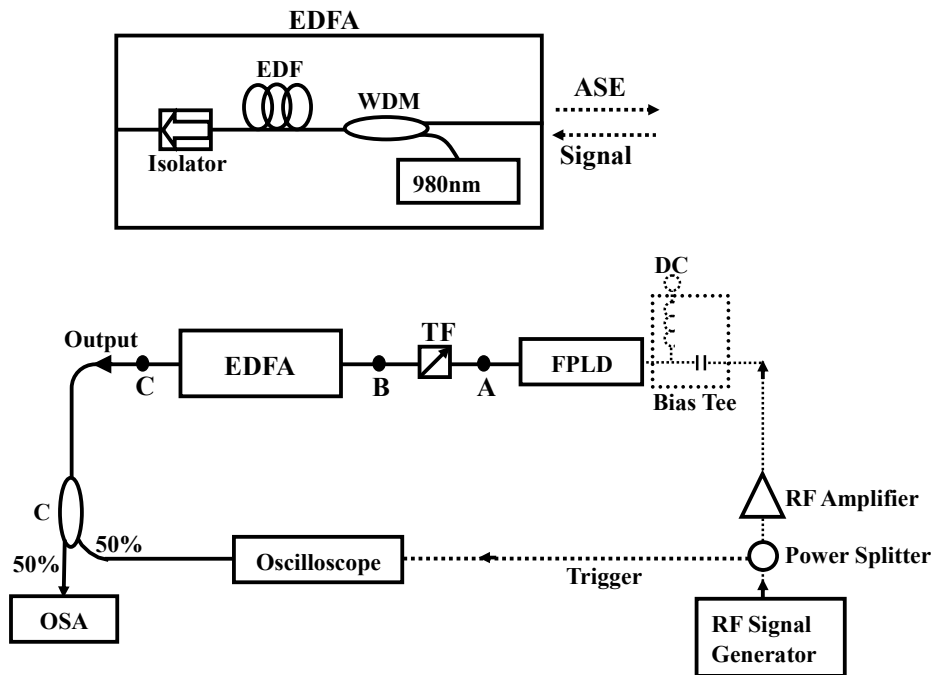

Fig. 2.11 Schematic diagram of the proposed system for the generation of wavelength-tunable optical pulses.

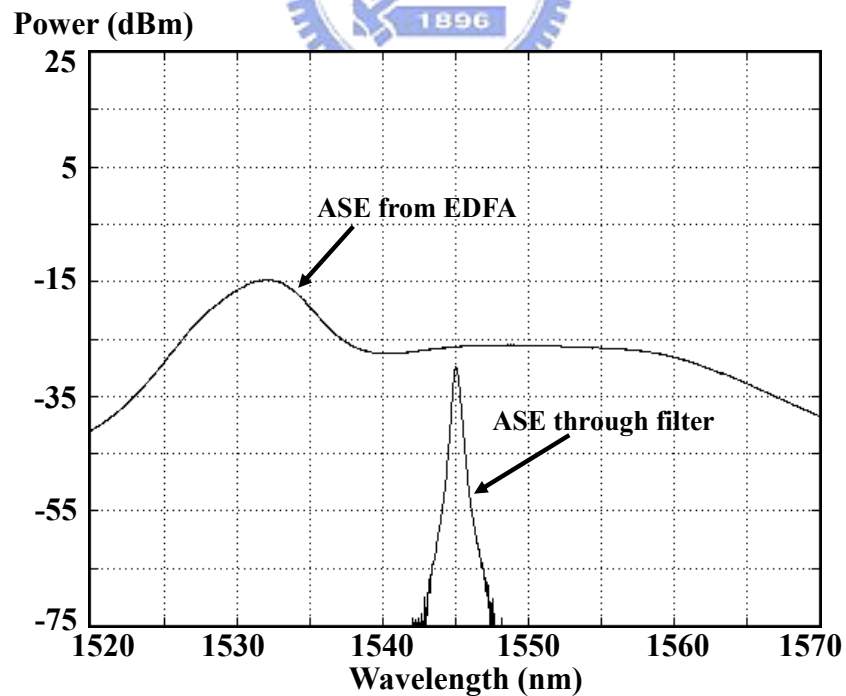

Fig. 2.12 Output spectra of the backward ASE and the ASE through the tunable filter.

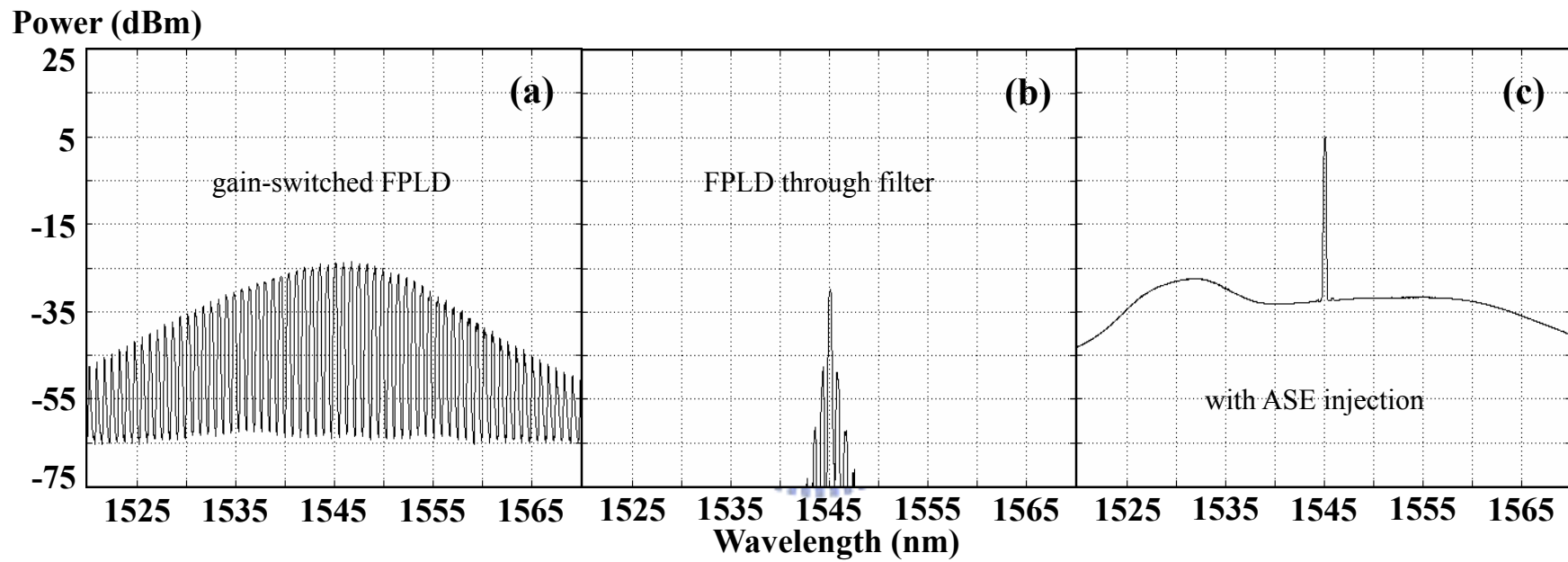

Fig. 2.13 Output spectra obtain at different points in Fig. 2.11, (a) at point “A”, (b) at point “B”, (c) at point “C”.

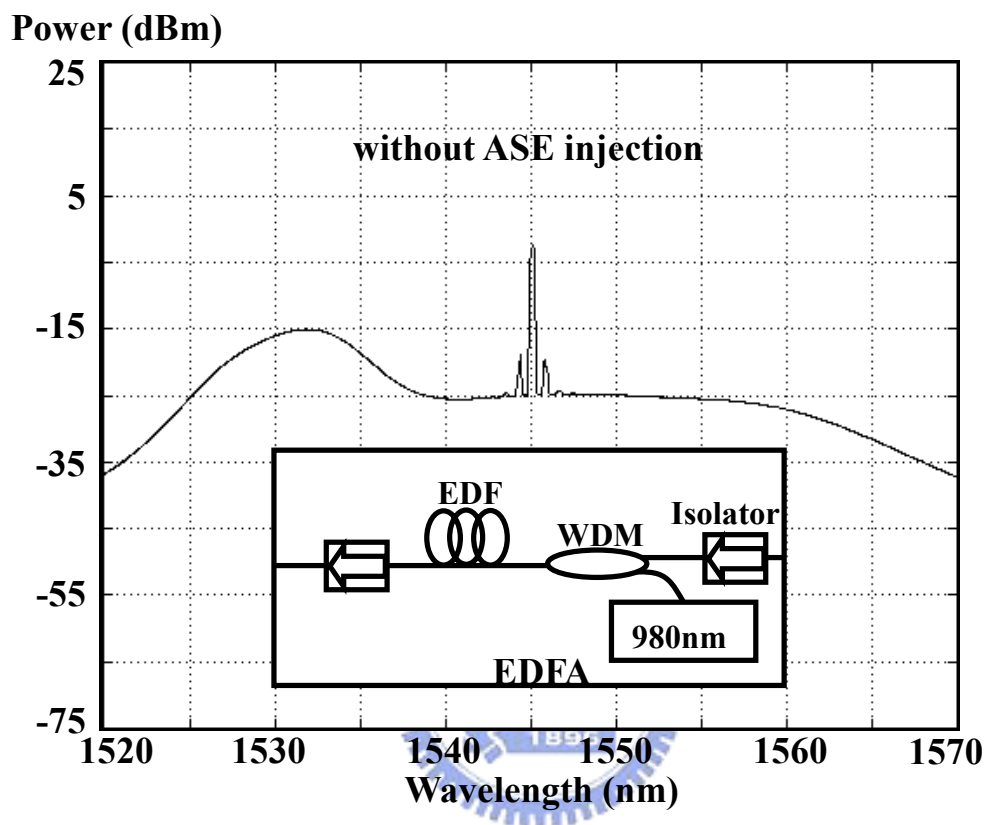

Fig. 2.14 Output spectrum of the system when the FPLD is without ASE injection.

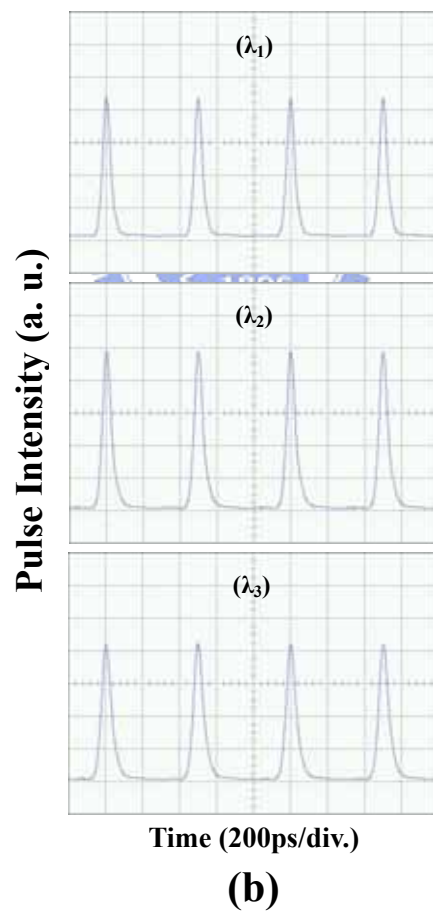
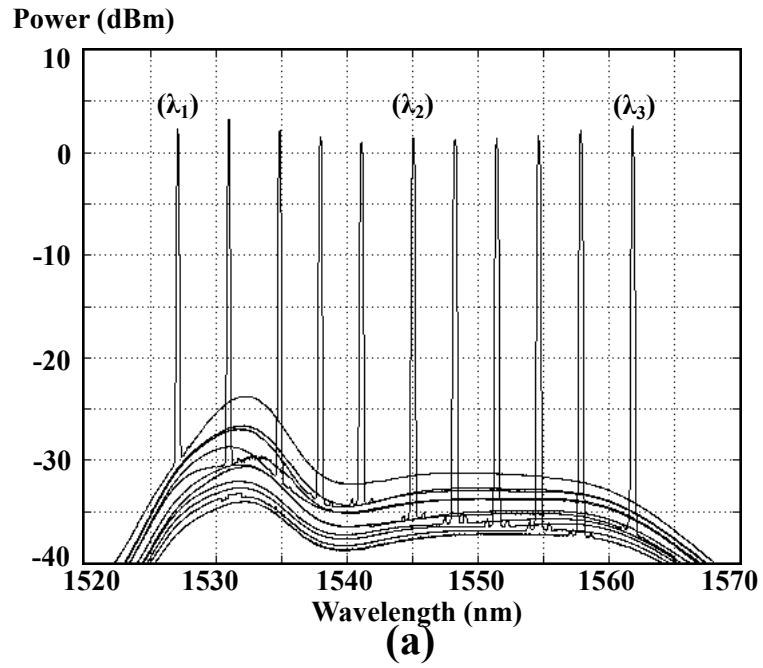

Fig. 2.15 (a) Output spectra and (b) pulse waveforms of the system when the central wavelength of the tunable filter is tuned to one of the wavelength of the FPLD lasing modes.

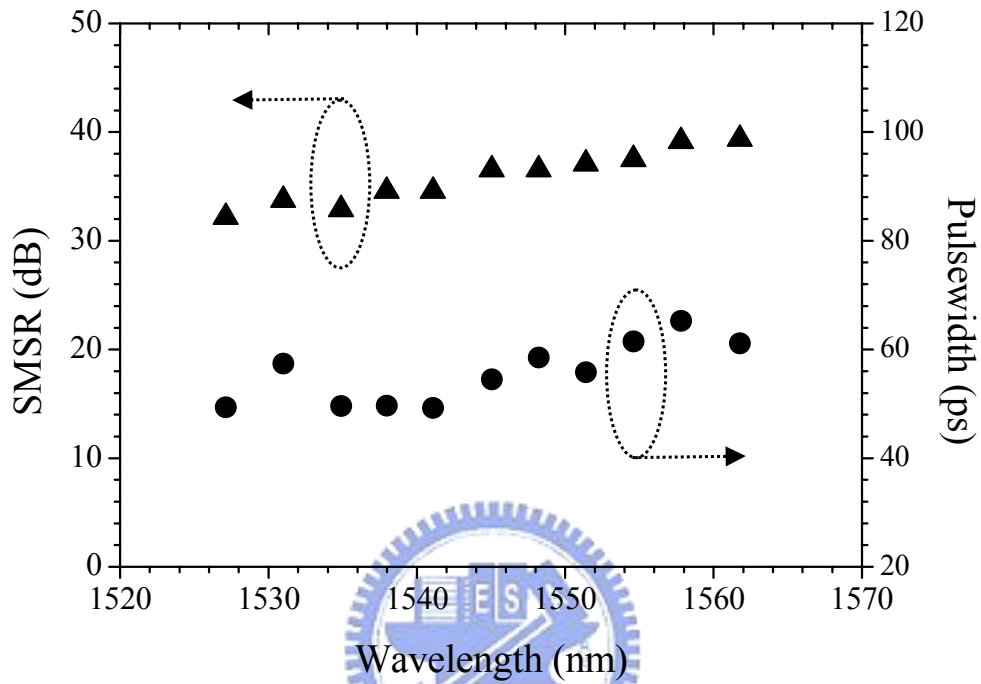

Fig. 2.16 The SMSR and pulswidth as a function of wavelengths.