

行政院國家科學委員會專題研究計畫 期中進度報告

總計畫(2/3)

計畫類別：整合型計畫

計畫編號：NSC93-2213-E-009-048-

執行期間：93年08月01日至94年07月31日

執行單位：國立交通大學資訊工程學系(所)

計畫主持人：楊啟瑞

共同主持人：陳耀宗，陳伯寧，張仲儒

報告類型：精簡報告

處理方式：本計畫可公開查詢

中 華 民 國 94 年 6 月 3 日

行政院國家科學委員會專題研究計畫成果報告

支援下一代無線與 FTTx 擷取之光纖都會網路技術

Optical Metro Core Network Transport Supporting Next Generation Wireless and FTTx Access Technology

計畫編號：NSC93-2213-E009-048

執行期限：93年8月1日至94年7月31日

主持人：楊啟瑞 國立交通大學資訊工程學系

共同主持人：張仲儒教授、陳伯寧教授（交大電信工程學系）

陳耀宗教授（交大資訊工程學系）

一、中文摘要

網際網路頻寬需求成長，及光纖波分多工(WDM)與無線通訊領域上之快速進展，導致下一代網路的設計與實現有巨大的改變。目前最有潛力的下一代網路技術即為光纖擷取網路及無線擷取網路。

本整合型研究計畫旨在探討以光纖都會核心為主幹，支援無線擷取網路與光纖擷取網路之基本傳輸及服務品質保證(QoS)技術。此計畫分為四項子計畫：子計畫一探討以packet-over-WDM (PoW)光纖架構為主的都會型核心網路骨幹技術，包含軟硬體研究平台之建構及訊務工程控制與分析；子計畫二主要探討基本無線傳輸之編碼與解碼技術，包含將通道參數估量和通道效應等化結合至通道編碼設計，以及如何於在以符元(symbol)為傳送單位的高速率傳輸調變下進行位元(bit)為解碼單位的軟性解碼(soft-decoding)；子計畫三負責探討以光纖架構為主之擷取網路，包含建立於全光巨量交換系統(OBS)之品質保證服務(QoS)機制，訊務彙集(traffic grooming)以及乙太光纖被動網路(EPON)之研究；子計畫四則負責研究快速行動性(High mobility)下無線網際網路之品質服務(QoS)技術，以能夠平順地支援無接縫式的即時多媒體串流(Real-time Multimedia Streaming)為目標。

關鍵詞：波分多工(WDM)，長途主幹網路，都會型網路(MAN)，波分多工封包(PoW)，光電路交換(OCS)，全光巨量交換系統(OBS)，服務品質保證(QoS)，媒體擷取控制(MAC)，無線擷取網路，訊務彙集，乙太光纖被動網路(EPON)，錯誤更正碼，編碼與解碼技術。

二、英文摘要

The ever-growing demand for Internet bandwidth

and recent advances in optical Wavelength Division Multiplexing (WDM) and wireless technologies brings about fundamental changes in the design and implementation of the next generation networks. The next challenge in wireless communications would be to reach high transmission rate under high mobility.

The main objective of this integrated project is the provision of the basic transport and QoS guarantees over metropolitan optical and wireless access networks interconnected via optical metro core backbone networks. There are 4 subprojects in the integrated project. Subproject 1 is responsible for the design, analyses, and testbed construction of packet-directly-over-WDM metro core networks; Subproject 2 focuses on the systematical design of an error-correcting code that can at the same time equalizes channel effect, and bit-wise soft-decision decoding for the prevailing symbol-based modulation scheme for future high speed transmission; Subproject 3 aims at the design and analyses of optical access networks including OBS-based optical transport with QoS guarantees, traffic grooming, and Ethernet over Passive Optical Network (EPON) and finally Subproject 4 then investigates QoS enabling technology under a high mobility wireless environment, in an attempt to smoothly support the seamless real-time multimedia streaming.

Keywords: Wavelength Division Multiplexing (WDM), Long-haul backbone network, Metropolitan Area Network (MAN), packet-over-WDM (PoW), Optical Circuit Switching (OCS), Quality-of-Service (QoS), Medium Access Control (MAC), Wireless Access Networks, Traffic Grooming, Ethernet over Passive Optical Network (EPON), Error Correcting Coding, Encoding and Decoding.

三、計畫緣由與目的

The ever-growing demand for Internet bandwidth and recent advances in optical Wavelength Division Multiplexing (WDM) and wireless technologies brings about fundamental changes in the design and implementation of the next generation networks. To support end-to-end data transport, there are three types of networks: wide-area long-haul backbone network, metropolitan core network, and local and access networks. First, due to steady traffic resulting from high degree of multiplexing, next-generation long-haul networks are based on the Optical Circuit Switching (OCS) technology by simply making relatively static WDM channel utilization. Second, a metropolitan core network behaves as transitional bandwidth distributors between the optical Internet and access networks. Unlike long-haul backbone networks, metro networks exhibit highly dynamic traffic demand, rendering static WDM channel utilization completely infeasible. Finally, access networks are responsible for providing bandwidth directly to end-users. Two most promising technologies have been optical access and wireless access networks, respectively. Due to superior performance of fiber optics and tremendous bandwidth demand, providing broadband access and services through optical access technology becomes indispensable. Finally, regarding wireless access networks, the new demand of wireless communications in recent years inspires a quick

advance in wireless transmission technology. Technology blossoms in both high-mobility low-bit-rate and low-mobility high-bit-rate transmissions. Apparently, the next challenge in wireless communications would be to reach high transmission rate under high mobility.

The main objective of this integrated project is the provision of the basic transport and QoS guarantees over metropolitan optical and wireless access networks interconnected via optical metro core backbone networks. As shown in Figure 1, Subproject 1 (PI: Prof. Maria Yuang) is responsible for the design, analyses, and testbed construction of packet-directly-over-WDM metro core networks; Subproject 2 (PI: Prof Po-Ning Chen) focuses on the systematical design of an error-correcting code that can at the same time equalizes channel effect, and bit-wise soft-decision decoding for the prevailing symbol-based modulation scheme for future high speed transmission; Subproject 3 (PI: Prof. Chung-Ju Chang) aims at the design and analyses of optical access networks including OBS-based optical transport with QoS guarantees, traffic grooming, and Ethernet over Passive Optical Network (EPON) and finally Subproject 4 (PI: Prof. Y. C. Chen) then investigates QoS enabling technology under a high mobility wireless environment, in an attempt to smoothly support the seamless real-time multimedia streaming.

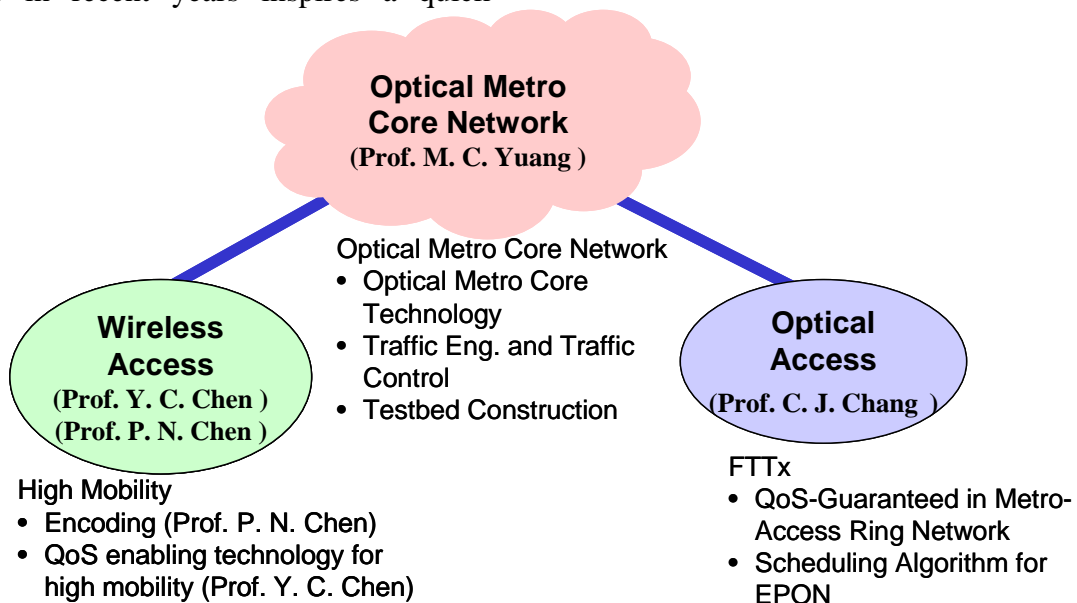

Figure 1. Relationship between sub-projects.

四、成果與討論

● 子計畫一：光纖都會核心網路技術研究

With advances in optical Wavelength Division Multiplexing (WDM) technologies [1] and its potential of providing virtually unlimited bandwidth, optical WDM networks have been widely recognized as the dominant transport infrastructure for future Internet backbone networks. To maintain high scalability and flexibility at low cost, WDM networks often include switching devices with different wavelength conversion powers [2,3] (e.g., no, limited- or full-range), and multi-granularity switching capability [4,5]. In particular, examples of Multi-Granularity Optical crossconnects (MG-OXC) include switching on a single lambda, a waveband (i.e., multiple lambdas), an entire fiber, or a combination of above.

One major traffic engineering challenge in such WDM networks has been the Routing and Wavelength Assignment (RWA) problem [3,6]. The problem deals with routing and wavelength assignment between source and destination nodes subject to the wavelength-continuity constraint [7] in the absence of wavelength converters. It has been shown that RWA is an NP-complete problem [7]. Numerous approximation algorithms [3,6] have been proposed with the aim of balancing the trade-off between accuracy and computational time complexity. In general, some algorithms [8,9] focused on the problem in the presence of sparse, limited, or full-range wavelength converters. Some others made an effort to either reduce computational complexity by solving the routing and wavelength assignment sub-problems separately [7], or increase accuracy by considering the two sub-problems [10] jointly. However, with the multi-granularity switching capability taken into consideration, most existing algorithms become functionally or economically unviable.

Our aim is to resolve the RWA problem in multi-granularity WDM networks particularly with Fiber Switch Capable (FSC-OXC) and Lambda Switch Capable (LSC-OXC) devices. It is worth mentioning that, as shown in Figure 2, an MG-OXC

node is logically identical to an individual FSC-OXC node in conjunction with an external separated LSC-OXC node. For ease of illustration, we adopt the separated node form throughout the rest of the report. The problem is in short referred to as RWA^+ .

In this sub-project, we have resolved a RWA^+ problem using the LRH method, which is a Lagrangean Relaxation based approach augmented with an efficient primal heuristic algorithm. With the aid of generated Lagrangean multipliers and lower bound indexes, the primal heuristic algorithm of LRH achieves a near-optimal upper-bound solution. A performance study delineated that the performance trade-off between accuracy and convergence speed can be manipulated via adjusting the Quiescence Threshold parameter in the algorithm. We have drawn comparisons of accuracy and computation time between LRH and the Linear Programming Relaxation (LPR)-based method, under three random networks. Experimental results demonstrated that, particularly for small to medium sized networks, the LRH approach using a termination requirement profoundly outperforms the LPR method and fixed-iteration-based LRH, in both accuracy and computational time complexity. Furthermore, for large sized networks, i.e., the USA and ARPA networks, numerical results showed that LRH achieves a near optimal solution within acceptable computation time. The above numerical results justify that the LRH approach can be used as a dynamic RWA^+ algorithm for small to medium sized networks, and as a static RWA^+ algorithm for large sized

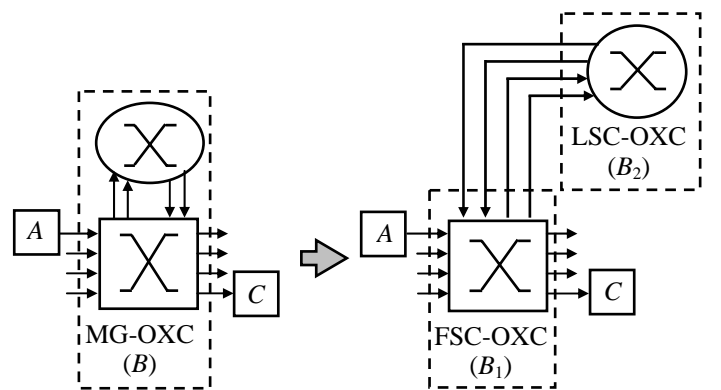

(a) An MG-OXC node (b) FSC-OXC and LSC-OXC nodes
Figure 2. A combined MG-OXC node and its logically identical separated node form.

networks.

● 子計畫二：適用於高速移動擷取網路的等化碼技術與高階調變位元軟性決策解碼技術之研究

The main technology obstacle for high-bit-rate transmission under high mobility is the seemingly highly time-varying channel characteristic due to movement; such a characteristic enforces the dependence between consecutive symbols, and further effects the difficulty in compensating the intersymbol interference. In principle, the temporal channel memory can be eliminated by an intersymbol space longer than the channel memory spread. An example is the IEEE 802.11a standard, in which 0.8- μ s “intersymbol space” is added between two consecutive 3.2- μ s OFDM symbols to combat any delay spread less than 800 nano seconds. In order to take advantage of the circular convolution technique, the 0.8- μ s “intersymbol space” is designed to be the leading 0.8- μ s portion of the 3.2- μ s OFDM symbol, which is often named the *cyclic prefix* [11]. Motivated by this, we experiment on a different view in the neutralization of channel memory, where the “intersymbol space” may be of use to enhance the system performance.

In order to examine the performance of our proposed system, we tempted to establish the capacity of the time-varying fading channel experimented. There have been several publications investigating the capacity of fading channels. The capacity of the flat Rayleigh fading channel has been studied in [12] under the assumption that the state of channel fading is perfectly known to both the transmitter and the receiver. While neither the transmitter nor the receiver knows the channel state information (CSI), investigation of the capacity of memoryless Rayleigh fading channels can be found in [13].

In this year, there are two questions on which we concentrate. The first is to experiment on a different view in the neutralization of channel memory, where the “intersymbol space” may be of use to enhance the system performance. The second question that the research aims at is that what the *capacity* of a time-varying channel, like Gauss-Markov [14,15], is. Seldom publications have been emerged in the

capacity study of Gauss-Markov channels. The understanding of this quantity helps the researchers to be fully understood of the gap between a transmission scheme and the underlying limit.

Based on the result of last year, the aims of this year are to design channel codes which have been considered the statistics properties of fading channels. In this work, we take the PCCC code and its respective iterative MAP decoder as a test vehicle to experiment on the idea that the *temporal channel memory* can be weakened to *nearly blockwise time-independence* by the insertive transmission of “random bits” of sufficient length between two consecutive blocks, for which these “random bits” are actually another parity check bits generated due to interleaved information bits. The simulation results show that the metrics derived based on blockwise independence with 2-bit blocks periodically separated by a *single* parity-check bit from the second component RSC encoder perform close to the CSI-aided decoding scheme, and is at most 0.9 dB away from the Shannon limit at $BER = 2 \times 10^{-4}$ when $h_0 = 1$ and $\sigma_v^2 = 0.001$. The result of the first part has been prepared for submission to IEEE communication letters. A natural future work is to extend the channel memory to higher order, and further examine whether the same idea can be applied to obtain well-acceptable system performance.

In the second part, we have remarked on four different definitions of channel capacities according to the transmitter/receiver with/without channel state information. We then turn to the derivation of the independent bounds for the channel capacity without CSI in both transmitter and receiver. We then found that if there is no LOS signal existing, the capacity of

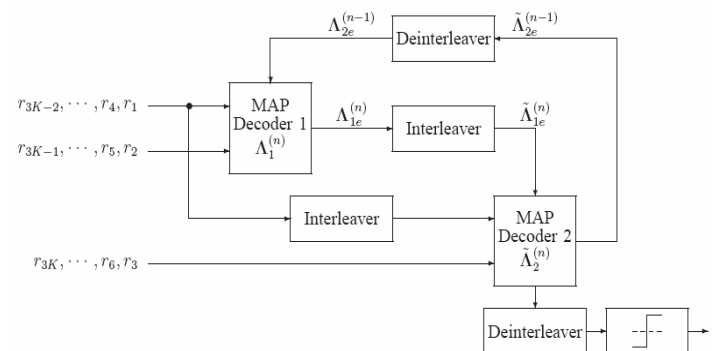

Figure 3. Iterative MAP algorithm.

the blind-CSI system will be reduced to zero.

● 子計畫三：光纖擷取網路技術之分析研究

In the studies on the prediction-based EPON uplink scheduling algorithms, it's found that a predictor can be utilized to estimate the new arrival packets in each ONU during the cycle time, and thus the mean packet queuing delay time can be reduced. This is because the new arrival packets can get the extra bandwidth reserved by the predictor and needn't to wait for another 'REPORT-GATE' signaling cycle time.

The scheduling architecture proposed in last year project can guarantee the delay criterion of voice service and support a good fairness to best-effort data service. In order to maintain the delay criterion of voice service, the maximum cycle time should be bounded [16]. We have shown the relationship between average packet delay of voice service and maximum cycle time (T_{max}) in last year report, where the average packet queuing delay will achieve one and half of the cycle time. That is, the average packet queuing delay will increase with the maximum cycle time (T_{max}).

In IPACT, we know that if the overhead, such as control messages and guard times, remain fixed during every cycle, the throughput will increase with the maximum cycle time (T_{max}). Thus, we can improve the bandwidth efficiency by increasing the maximum cycle time. However, according to the content mentioned above, this will lead to increasing average packet queuing delay.

In this sub-project, we proposed the prediction-based scheduler architecture for the uplink media access mechanism of EPON networks. A moving average method is chosen to estimate the number of arrived packets during a cycle right after the REPORT message has been sent back to the OLT and the new GATE message has been issued to the ONU. The simulation results show that, as comparing with the performance of the non-prediction-based scheduling scheme, the average packet queuing delay of the voice service will be greatly decreased with a slight degradation in throughput. Furthermore, with the

lower queuing delay, the maximum cycle time can be extended to improve the performance of system throughput with the side effect of increasing queuing delay for the voice service. However, the increased queuing delay of the voice service is still within the specified delay bound.

In the simulation, we have also found that the moving average method cannot perfectly estimate the behavior of the self-similar traffic. This is because the variation of self-similar traffic is large, and the predictor will over estimate frequently. We believe that there exist better predictors that can reduce the prediction error in this model.

We will continue the project according to the results of this year. In the enhanced Prediction-Based Scheduling Algorithm for EPON, we will check the EPON final standard to our simulation model; Making a new traffic control mechanism to meet the IEEE 802.3ad requirements; developing a new LAN traffic pattern for the self-similar packets; applying the optimum traffic pattern to the simulation programs to get the optimum results; enhancing the effective prediction algorithm to improve the minimization of packet delay and maximization of bandwidth utilization.

On the other hand, we have been devoted in the studies about the traffic grooming problem over WDM optical networks. In order to efficiently utilize the network resources, the traffic-grooming technique will be employed to multiplex several (lower-speed) traffic streams with the same route into one high-speed stream and transmitted by one individual optical carrier.

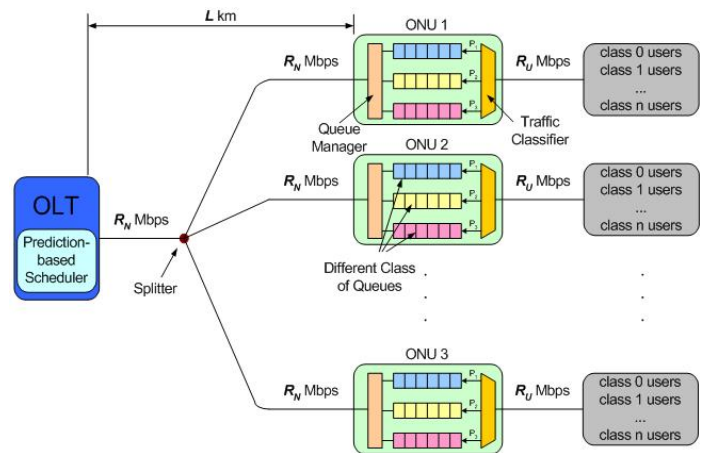

5 Figure 4. A prediction-based EPON model.

● 子計畫四：快速行動擷取網路中之品質服務支援技術研究

Wireless local area networks have become extremely popular in recent years. The wireless services may encounter some problems under different environments, and there are more emerging multimedia streaming applications being developed. When users of these applications move from the coverage area of one AP to the other, the services must be handed over in approximately 150 milliseconds, otherwise the user will experience the jitter. If the handoff time is much larger than 150ms, the quality would be getting worse. This noticeable problem needs to be solved. Many approaches have been proposed from different aspects to reduce the handoff impact. Some focus on layer 2 handoff to reduce the scan, authentication and association latency. Others focus on layer 3 handoff to alleviate the registration and authentication time. The typical solution for reducing handoff time is Hierarchical Mobile IP with Fast handover protocol [17]. Fast handover protocol [18] needs layer 2 information to early trigger the handoff and it spends approximately 100ms which is much smaller than 3 seconds required by original Mobile IP. This small handoff period allow us to provide a multimedia streaming service during handoff without suffering jitter problem.

Besides handoff, security and authentication issues also become more important nowadays. If we

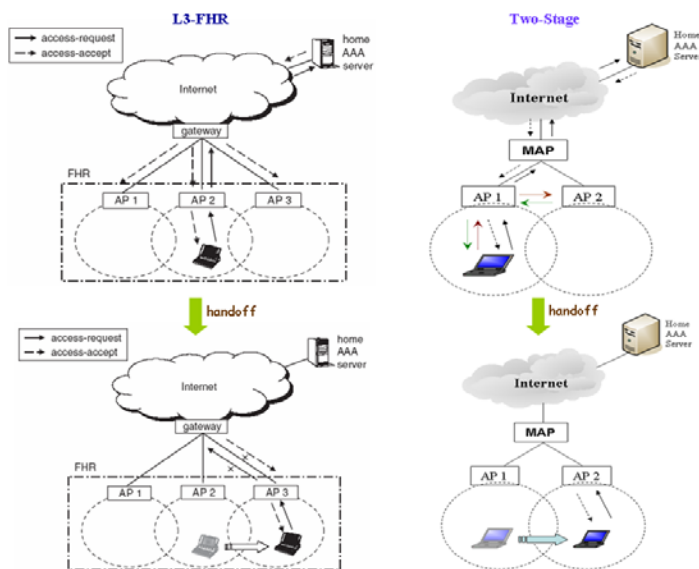

Figure 4. L3-FHR & Two-Stage message flow.

like to enhance the security or to perform authentication, it will add a certain amount of handoff time in addition to the original layer 2 and layer 3 handoff. This is a tradeoff between authentication and QoS, and we need some method to minimize the impact if we add authentication process on it. Fast handover could provide better QoS for roaming devices, based on this advantage, we construct a user authentication signaling that allows the access router to authenticate the mobile node (MN).

To achieve low latency handoff, we make use of pre-registration signaling called fast handover protocol to piggyback user's information to authenticate with new target AP temporarily for reducing the authentication time during handoff period, it is called "two-stage authentication" as shown in Figure 5. Our two-stage authentication scheme consists of pre-authentication and formal authentication.

A mobile node needs to perform AAA/Mobile IP [19] initial registration when it enters into the new MAP (Mobility Anchor Point) domain. The Home Agent generates keys and authenticates the mobile node when it receives the AAA/Mobile IP registration message. Then, the Home Agent replies the registration to the mobile node through MAP, which then checks the authentication status, signs a certificate CA_{MAP} and adds group key for the mobile node into registration reply message. The mobile node derives the CA_{MAP} after performing the AAA/Mobile IP registration. Then, the mobile node moves from PAR (Previous Access Router) to NAR (New Access Router), it triggers the pre-registration called fast handover signaling to reduce the registration time. We try to make use of this signaling to piggyback some information to pre-authenticate the MN with new target AP temporarily. Also, the MN needs to complete the formal authentication process after handoff in a given limited time. The MN generates a credential to register with new target AR (AP) through fast handover signaling for deriving the temporarily access right in the new domain. After handoff, the mobile node can receive packets quickly by sending this credential to the target AR to present

its existence under target AR's coverage. So, the MN doesn't need to wait for completing the authentication process to receive packets. NAR uses CA_{MAP} to identify the mobile node and to register the credential of the mobile node in NAR's authentication table. NAR will return the expiration time of the credential and CA_{NAR} signed by NAR through fast handover signaling to the mobile node. After Layer 2 handoff, the MN can use this credential to pass temporarily authentication and extend its authentication expiration time in NAR's authentication table. CA_{NAR} is for formal authentication usage.

The two-stage authentication scheme can enhance the performance of wireless handover if authentication mechanism is used. Different from the L3-FHR authentication scheme that authentication information is broadcasted by gateway to all L3-FHR [20] ARs(APs) shown in Figure 5, a MN just sends a copy of authentication information to the target ARs (APs) in two-stage authentication scheme. As a result, our proposed scheme can reduce the packet loss rate and authentication time. Our scheme can reduce the original IEEE 802.11 authentication process time because it pre-sends the identity of the MN to target AR(AP). We try to modify this scheme to co-work with IEEE 802.1x to reduce the authentication time and to provide a better authentication mechanism during handoff period in the future research.

五、計畫執行管理與自評

本整合型研究計畫「支援下一代無線與FTTx擷取之光纖都會網路技術」為三年期之計畫。在第一年，透過跨院、跨校與跨國合作，架設了OPSINET離形網路來觀察並了解光纖都會型網路的行為，並針對光纖都會型網路的特性來提供各子計畫在無線與FTTx擷取之技術合作。

今年延續著在第一年所獲致之經驗，各子計畫皆有豐碩成果。子計畫一在光纖都會核心網路上，完成了路由與波長分配(RWA⁺)之關鍵技術；子計畫二在無線環境之下，編解碼技術有重大突破；子計畫三在EPON網路上，以新排程法有效提升系統效能；及子計畫四透過提前認證，在無線漫遊可達到快速交遞。

研究成果已投稿或發表於國際會議與期刊，並申請專利，成果如下：

- 子計畫一之報告已刊載於 *IEEE J. Selected Areas in Communications*。
- 子計畫二之報告已投稿 *IEEE communication letters*。
- 子計畫三目前以「EPON網路的上行頻寬分配演算法」申請專利中。
- 子計畫四之報告及相關內容已投稿兩篇於 *IEEE Communication Letters*。

六、參考文獻

- [1] B. Mukherjee, "WDM Optical Communication Networks: Progress and Challenges," *IEEE J. Select. Areas Commun.*, vol. 18, no. 10, Oct. 2000, pp. 1810-1824.
- [2] R. Ramaswami, and G. Sasaki, "Multiwavelength Optical Networks with Limited Wavelength Conversion," *IEEE/ACM Trans. Networking*, vol. 6, no. 6, Dec. 1998, pp. 744-754.
- [3] R. Ramaswami, and K. Sivarajan, *Optical Networks-A Practical Perspective*, 2nd Edition, Morgan Kaufmann, 2002.
- [4] P. Ho, and H. Mouftah, "Routing and Wavelength Assignment with Multigranularity Traffic in Optical Networks," *Journal of Lightwave Technology*, vol. 20, no. 8, Aug. 2002, pp. 1292-1303.
- [5] K. Zhu, H. Zhu, and B. Mukherjee, "Traffic Engineering in Multigranularity Heterogeneous Optical WDM Mesh Networks Through Dynamic Traffic Grooming," *IEEE Networks*, vol. 17, no. 2, March/April 2003, pp. 8-15.
- [6] B. Mukherjee, *Optical Communication Networks*, McGraw-Hill, 1997.
- [7] D. Banerjee, and B. Mukherjee, "A Practical Approach for Routing and Wavelength Assignment in Large Wavelength-Routed Optical Networks," *IEEE J. Select. Areas Commun.*, vol. 14, no. 5, Sep. 1996, pp. 903-908.
- [8] C. Xiaowen, L. Bo, and I. Chlamtac, "Wavelength Converter Placement under Different RWA Algorithms in Wavelength-Routed All-Optical Networks," *IEEE Trans. Commun.*, vol. 51, no. 4, April 2003, pp. 607-617.
- [9] H. Qin, S. Zhang, and Z. Liu, "Dynamic Routing and Wavelength Assignment for Limited-Range Wavelength Conversion," *IEEE Commun. Letters*, vol. 7, no. 3, March 2003, pp. 136-138.
- [10] A. Mokhtar, and M. Azizoglu, "Adaptive Wavelength

- Routing in All-Optical Networks,” *IEEE/ACM Trans. Networking*, vol. 6, no. 2, April 1998, pp. 197-206.
- [11] IEEE Std 802.11a-1999, *Part 11: Wireless LAN Medium Access Control (MAC) and Physical Layer (PHY) specifications: High-speed Physical Layer in the 5 GHz band*, Sept. 1999.
- [12] W. C. Y. Lee, “Estimate of channel capacity in Rayleigh fading environment,” *IEEE Trans. Veh. Technol.*, vol. 39, no. 3, pp. 187-189, Aug. 1990.
- [13] I. C. Abou-Faycal, M. D. Trottand and S. Shamai, “The capacity of discrete-time memoryless Rayleigh-fading channels,” *IEEE Trans. Inform. Theory*, vol. 47, no. 4, pp. 1290-1301, May 2001.
- [14] H. Chen, K. Buckley and R. Perry, “Time-recursive maximum likelihood base sequence estimation for unknown ISI channels,” in *Proc. of 34th Asilomar Conf. Circuits, Systems, Computers*, pp. TA8a14: 1-5, Nov. 2000.
- [15] H. Chen, R. Perry and K. Buckley, “On MLSE algorithm for unknown fast time-varying channels,” *IEEE Trans. Commun.*, vol. 51, pp.730-734, May. 2003.
- [16] G. Kramer, B. Mukherjee, S. Dixit, Y. Ye, and R. Hirth, “Supporting differentiated classes of service in Ethernet passive optical networks,” *J. Opt. Networks*, vol. 1, no. 8/9, pp. 280-298, Aug. 2002.
- [17] Nicolas Montavont et.al., “Handover Management for Mobile Nodes in IPv6 Networks,” *IEEE Communications Magazine*, August 2002.
- [18] Robert Hsieh, Aruna Seneviratne, Hesham Soliman and Karim El-Malki, “Performance analysis on Hierarchical Mobile IPv6 with Fast-handoff over End-to-End TCP,” *Proceedings of GLOBECOM*, Taipei, Taiwan 2002.
- [19] Pat R. Calhoun et. al., “Diameter Mobile IPv4 Application,” *Internet Draft, IETF, draft-ietf-aaa-diameter-mobileip-20.txt*, August 2004
- [20] S.Pack, Y. Choi, “Fast handoff scheme based on mobility prediction in public wireless LAN systems,” *IEE Proc.-Commun.*, Vol. 151, No. 5, October 2004.