

Reliable tree-type passive optical networks with self-restorable apparatus

Chien Hung Yeh^{1*}, Fu-Yuan Shih², Gee-Kung Chang³, *Fellow, IEEE*, Sien Chi^{2,4}

¹Information and Communications Research Laboratories,
Industrial Technology Research Institute, Chutung, Hsinchu 31040, Taiwan

²Department of Electrical Engineering, Yuan Ze University, Chungli, Taoyuan 32003, Taiwan

³School of Electrical and Computer Engineering, Georgia Institute of Technology, Atlanta, GA 30332-0250

⁴Department of Photonics and Institute of Electro-Optical Engineering,
National Chiao Tung University, Hsinchu 30010, Taiwan

*Corresponding author: depew@itri.org.tw

Abstract: We propose and investigate a simply self-restored tree-type time-division-multiplexed passive optical network (TDM-PON) with duplex fiber system against the fiber failure. The new proposed optical line terminal (OLT), optical network unit (ONU), and remote node (RN) can be used to prevent and protect the occurrence of fiber failure in the self-protected tree-type PON. The protection and restoration time of the access network can be archived within 7 ms in this experiment. In addition, the performances of data traffic for the fiber access network are also analyzed and discussed.

©2007 Optical Society of America

OCIS codes: (060.4261) Networks, protection and restoration; (060.4257) Networks, network survivability

References and links

1. F.-T. An, D. Gutierrez, K. S. Kim, J. W. Lee, and L. G. Kazovsky, "SUCCESS-HPON: A next-generation optical access architecture for smooth migration from TDM-PON to WDM-PON," *IEEE Commun. Mag.* **43**, S40–S47 (2005).
2. G. Kramer and G. Pesavento, "Ethernet passive optical network (EPON): building a next-generation optical access network," *IEEE Commun. Mag.* **40**, 66–73 (2002).
3. IEEE Standard for Information Technology, IEEE Std 802.3ah-2004 (IEEE, 2004), pp.01–623.
4. ITU-T Recommendation G.984.2-2003, "Gigabit-capable passive optical networks (GPON): physical media dependent (PMD) layer specification," (ITU, 2003).
5. M. Abrams, P. C. Becker, Y. Fujimoto, V. O'Byrne, and D. Piehler, "FTTP deployments in the United States and Japan-equipment choices and service provider imperatives," *J. Lightwave Technol.* **23**, 236–246 (2005).
6. K. D. Langer, J. Grubor and K. Habel, "Promising evolution paths for passive optical access networks," in *ICTON'04*, 2004, pp. 202–207.
7. A. D. Hossain, H. Erkan, R. Dorsinville, M. Ali, A. Sham, and C. Assi, "Protection for a ring-based EPON architecture," in *International Conference on Broadband Networks*, 2005, pp. 626–631.
8. X. Sun, Z. Wang, C.-K. Chan, and L.-K. Chen, "A novel star-ring protection architecture scheme for WDM passive optical access networks," in *Optical Fiber Communication Conf.* 2005, Tech. Dig., 2005, pp. JWA53.
9. W.-P. Lin, M.-S. Kao, and S. Chi, "The modified star-ring architecture for high-capacity subcarrier multiplexed passive optical networks," *J. Lightwave Technol.* **19**, 32–39 (2001)

1. Introduction

Due to the surge of demands in high-speed data access and triple-play services, fiber-to-the-home (FTTH) field deployments and the needs for related standardizations are becoming more important lately. Therefore, the architecture design, operation, and services delivery of passive optical network (PON) are technological challenges in overcoming the last mile bottleneck in broadband optical access network [1], [2]. This is because that fiber access network can provide huge bandwidth for both downstream and upstream traffic and relieve the bottleneck due to mismatch between current network capacity and ever growing demand of bandwidth and services. Therefore, time-division-multiplexing PON (TDM-PON) systems such as Ethernet-PON (E-PON) and Gigabit-PON (G-PON) have been already standardized

[3], [4]. Defined by these standards, TDM-PONs are currently operating at nominal line rates of 1.25 Gbits/s for EPON and 2.5 Gbits/s for GPON, respectively [5]. Generally, the architectures of PONs are designed using three different topologies, which are bus-, tree- and ring-structure. Point-to-multipoint connectivity between the optical line terminal (OLT) and each optical network unit (ONU) is obtained employing a passive splitting device at the remote node (RN). Data link from an OLT to an ONU is called “downstream” (point-to-multipoint) and link from an ONU to the OLT is called “upstream” (multipoint-to-point). There are two wavelengths used in TDM-PONs: 1310 nm wavelength (λ_{up}) for the upstream and 1490 nm wavelength (λ_{down}) for the downstream. If a fiber link between the OLT and one of the ONUs is broken, the affected ONU will be out of service. Thus, to verify and provide fiber network protection, the conventional method of using alternative protection paths can be used and implemented. However, the associated operation and maintenance requirements are complicated and costly. It also needs adding many optical devices in their access networks [6]-[9]. Besides, these conventional methods only provide limited protection in the fiber paths between RN and each ONUs.

In this paper, we propose and experimentally demonstrate self-restored architecture for the cost-effective, tree-based TDM-PON to detect and prevent the occurrence of fiber failure. The proposed structure can protect the transmission path failure in the feeder fiber as well as the failure in distributed fibers. The performance of the downstream and upstream data traffic in this proposed TDM-PON architecture have also been analyzed.

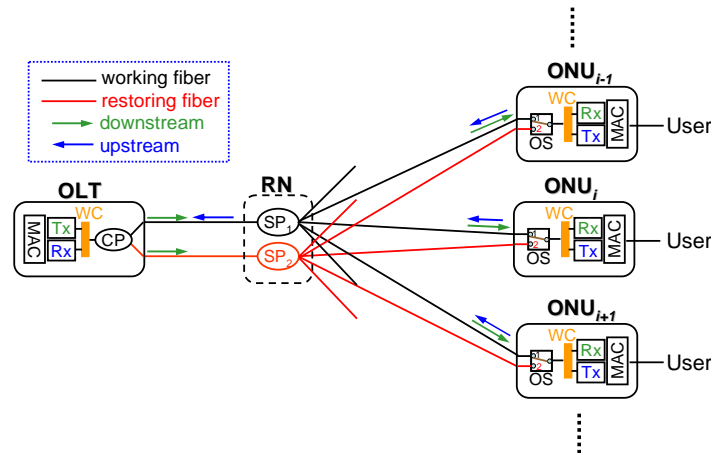

Fig. 1. Proposed self-restored tree-based TDM-PON architecture without fiber failure and each ONUs connect to working fiber. The black and red fibers are working and restoring fiber paths.

2. Protection apparatus

Conventional tree-type TDM-PON scheme is a point-to-multipoint connectivity between an OLT and multiple ONUs, and at the RN employs a $1 \times n$ optical splitter (SP) to act as a passive branching device for serving n ONUs. When a fiber cut on fiber branch “ i ” (on distributed fiber), the data traffic is unreachable from ONU _{i} to OLT. It will cause the ONU _{i} without data connecting due to the fault. If a fiber fault occurs on the feeder fiber between OLT and RN, the entire downlink and uplink traffic will disconnect. That is to say, each upstream signal after the fault point will be unable to advance. That is a very serious problem in connectivity. To achieve the desired network survivability, the past protected operation adding more optical components on OLT and ONU with complex operating mechanism and using dual-fiber path were recommended [4], [6]-[9]. That could cause the self-protected network becoming complex and also increase the cost.

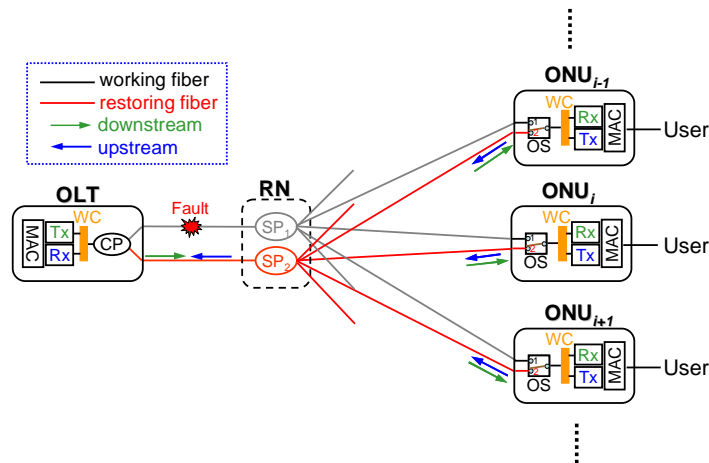

Fig. 2. Proposed self-restored tree-based TDM-PON architecture when a fiber failure occurs on feeder fiber between OLT and RN.

Therefore, Figure 1 shows our proposed self-restored scheme for the cost-effective tree-based TDM-PON with duplex fiber system against fiber fault. The traffic of downstream (green arrow line) and upstream (blue arrow line) is also drawn in Fig. 1 when the PON without any failure. The RN have two $1 \times n$ SPs to connect the working and restoring fiber path between OLT and multiple ONUs. In Fig. 1, the black fiber represents working fiber and the red fiber is restoring fiber against fiber fault. The OLT adds a 1×2 optical coupler (CP) in front of 1490/1310 WDM coupler (WC) to split two wavelengths connecting the working and restoring fibers. Each ONU adds a 1×2 optical switch (OS) in front of 1490/1310 WDM coupler to select connecting the working or restoring fibers. The OS is originally located at point “1” initially when the access network is in normal. Even though the ONU receives the downstream signal from restoring fiber path in normal state; the direction of OS could block the downstream signals advancing. Once the data link is disconnecting through working fiber, the switching direction of OS will switch to reconnect the restoring fiber automatically.

When a fiber fault occurs between OLT and RN (on feeder fiber), as shown in Fig. 2, multiple ONUs behind the fault point does not receive a downstream signal through working path. At the same time, the media access control (MAC) of each ONUs will control the OS swapping to point “2” immediately for reconnecting data through the restoring path, as seen in Fig. 2. Then, when a failure occurs on one fiber branch “ i ” (on distributed fiber) as illustrated in Fig. 3, it will affect the connectivity of OLT and ONU_i . Immediately, the OS of ONU_i could also switch to point “2” for reconnecting data through the restoring fiber path. In other words, the OS of each ONUs could be switched automatically by MAC to connect the working or restoring fibers for data traffic. In addition, compared with the past studies [6]-[9], the protection apparatus can simplify the restoring mechanism and reduce the processing load on OLT. As a result, the proposed access network not only has simple scheme and operating method but has cost-effective. The proposed self-protected PON is very useful for the next generation FTTH access networks.

In the ITU-T G.983.1, two OLTs are used in full duplex network to prevent and protect the fiber fault. Compared with the full duplex system specified in the ITU-T G.983.1, the proposed architecture only uses single OLT against fiber fault in order to reduce the cost for fiber protection. However, when the OLT breaks down, the proposed fiber access network will be disconnected. Of course, the proposed protection network could use two OLTs to avoid the OLT breaking down.

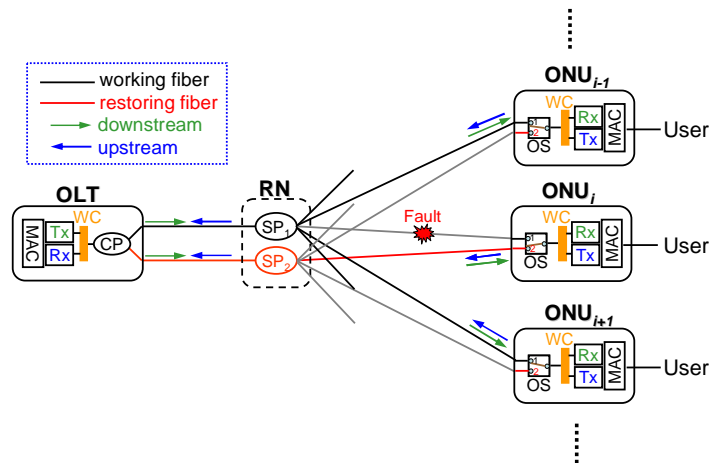

Fig. 3. Proposed self-restored tree-based TDM-PON architecture when a fiber failure occurs on distributed fiber between RN and ONU_i.

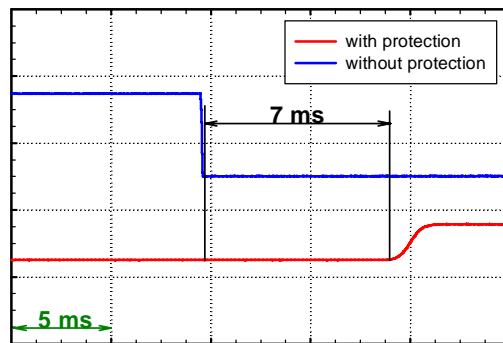

Fig. 4. Protection and restoration time of the proposed self-restored PON is within 7 ms.

3. System testing and analysis

To verify the performance of the proposed self-restored tree-type TDM-PON, an experiment is performed. Figure 1 shows the experimental setup in the self-protected architecture for serving eight OUNs. In our experiment, a transmission distance between OLT and each ONU is set to 20 km long for the working and restoring fiber paths. The 1490 nm downstream and 1310 nm upstream wavelengths have 1.25 Gb/s direct modulations. Besides, the output powers of 1490 and 1310 nm lasers are 2.0 and 1.8 dBm. In regard to the power budget of protection PON system, the traffic signal will traverse a 1×2 CP (~ 3 dB), a 1×8 SP (~ 9 dB), an OS (~ 1 dB) and about 20 km standard single mode fiber (SSMF) (~ 4 dB), thus the total loss budget is about 17 dB at least, when the data traffic without and with fiber protection. In the proposed system, the protection and restoration time can be measured within 7 ms, as shown in Fig. 4. In real system, the requirement for the protection and restoration time [7] was within 2 ms for no loss of traffic and fault detection. The proposed protection architecture will bring package loss due to the additional optical switch. In addition, the bit error rate (BER) performances are measured by a 1.25 Gb/s non-return-to-zero (NRZ) pseudo random binary sequence (PRBS) with a pattern length of $2^{31}-1$ for the downstream and upstream traffic without and with protections (on the working and restoring paths) no matter the fiber fault occurs on the feeder or distributed fibers (as seen in Figs. 2 and 3), respectively. Therefore, Figure 5 shows the BER performance of (a) downstream and (b) upstream traffic at 1.25 Gb/s

modulation through the working and restoring fiber paths without and with protection, respectively. The observed optical power penalties of Figs. 5(a) and 5(b) are very smaller when the BER is 10^{-9} .

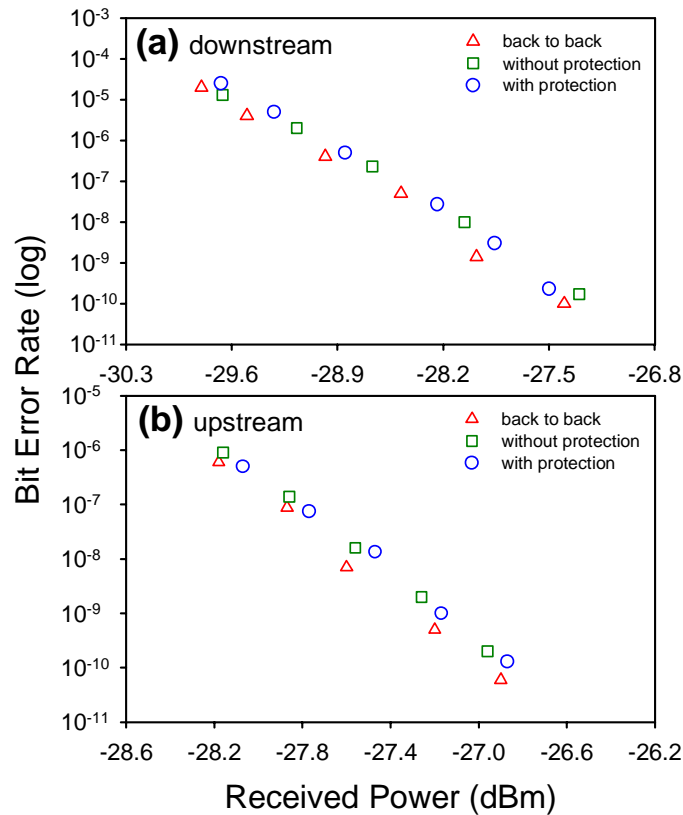

Fig. 5. BER performances of (a) downstream and (b) upstream traffic at 1.25 Gb/s modulation through the working and restoring fiber paths between OLT and ONU, without and with protection no matter the fiber fault occurs on the feeder or distributed fibers, respectively.

4. Conclusion

In summary, we have proposed and investigated a self-restored, tree-type TDM-PON with duplex fiber system against the fiber failure. The new proposed architecture with enhanced optical line termination, optical network unit, and remote node are designed and implemented to detect and restore fiber failure in the self-protected PON. The protection and restoration time of this proposed method can be achieved within 7 ms of the occurrence of a failure. As a result, the proposed TDM-PON access network protection is designed with a simple and elegant scheme while achieving ease of operation, and cost-effective. The performance analysis of up-stream and down-stream data traffic for the access network have also discussed and reported.

Acknowledgment

Authors would like to thank C. S. Lee and F. C. Chao for their help of the experimental set up and data collection.